



**THE DATASHEET OF  
DS1100PED-3-001**



# ARTESYN DS1100PED

1100 Watts Distributed Power System



Advanced Energy's Artesyn DS1100PED-3 power supply features a very wide 90 to 264 Vac input voltage range and employ active power factor correction to minimize input harmonic current distortion and to ensure compliance with the international EN61000-3-2 standard. The power supplies also feature active ac inrush current control, to automatically limit inrush current at turn-on to 55 A maximum.

The DS1100PED-3 can deliver up to 91.6 A from its main +12 Vdc payload output, and up to 3 A from its +12 Vdc Standby output. The form factor is 1U and may be used in single or in redundant configurations.

DS1100PED-3 has a power density of more than 24 Watts per cubic inch, and compliant 80 plus Platinum Efficiency, its efficiency will be 94% at nominal high AC line with 50 percent full load.

## SPECIAL FEATURES

- 1100 W output power
- High-power and short form factor
- 1U power supply
- High-density design: 24 W/in<sup>3</sup>
- Active Power Factor Correction
- EN61000-3-2 Harmonic compliance
- Inrush current control
- 80plus Platinum efficiency
- N+1 or N+N redundant
- Hot-pluggable
- Active current sharing
- Full digital control
- PMBus compliant
- Accurate input power reporting
- Compatible with Artesyn's Universal PMBus GUI
- Reverse airflow option
- Two-year warranty

## COMPLIANCE

- EMI Conducted/Radiated Class A Limits + 6 dB margin
- EN61000-4-11

## SAFETY

- UL/cUL 60950 (UL Recognized)
- DEMKO+ CB Report EN60950
- EN60950
- CE Mark
- China CCC
- BSMI

## DATA SHEET

### Front-end Bulk Power

#### Total Output Power:

1100 W continuous

#### Wide Input Voltage:

90 to 264 Vac



## ELECTRICAL SPECIFICATIONS

Input						
Input range	90 - 264 Vac					
Frequency	47 Hz to 63 Hz					
Efficiency	94.0% peak					
Max input current	14.5 Arms					
Inrush current	55 Apk					
Conducted EMI	Class A					
Radiated EMI	Class A					
Power factor	> 0.9 beginning at 20% load					
ITHD	10%					
Leakage current	1.4 mA					
Hold-up time	10 ms at full load					
Output						
	Main DC Output			Standby DC Output		
	MIN	NOM	MAX	MIN	NOM	MAX
Nominal setting	-0.20%	12	0.20%	-1%	12	1%
Total output regulation range	11.4 V		12.6 V	11.4 V		12.6 V
Dynamic load regulation range	11.4 V		12.6 V	11.4 V		12.6 V
Output ripple			120 mVp-p			120 mVp-p
Adjustment range		TBD		0.1 A		3.0 A
Output current	2 A <sup>1</sup>		91.76 A			
Current sharing	Within 3.7 A from 20% to 100% load			N/A		
Capacitive loading	2000 $\mu$ F		40,000 $\mu$ F	47 $\mu$ F		680 $\mu$ F
Start-up from AC to output			2200 ms			1700 ms
Output rise time	5 ms		50 ms	2 ms		60 ms

<sup>1</sup> Minimum current for transient load response testing only. Unit is designed to operate and be within output regulation range at zero load.

Protections			
Main Output	MIN	NOM	MAX
Overcurrent protection <sup>2</sup>	120%		150%
Overvoltage protection <sup>1</sup>	13.5 V		15.0 V
Undervoltage protection	10.5 V		11.0 V
Overtemperature protection		Yes	
Fan fault protection		Yes	
Standby Output			
Overcurrent protection <sup>3</sup>	120%		150%
Overvoltage protection <sup>3</sup>	13.5 V		15.0 V
Undervoltage protection	10.0 V		11.0 V

<sup>1</sup> Latch mode

<sup>2</sup> Autorecovery if the overcurrent is less than 120% and last only for <500 ms

<sup>3</sup> Standby protection is auto-recovery

## POWER DERATING

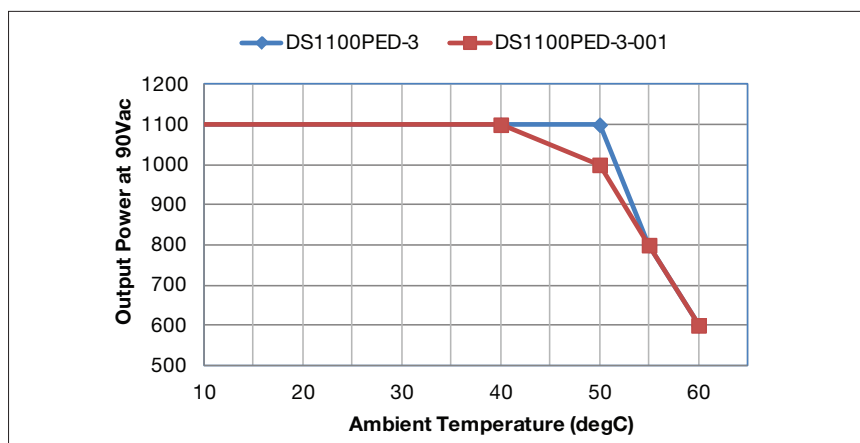

## ORDERING INFORMATION

Model Number	Nominal Main Output	Standby Output	Airflow Direction
DS1100PED-3	12 V	12 V @ 3 A	Std (forward)
DS1100PED-3-001	12 V	12 V @ 3 A	Reverse <sup>1</sup>

<sup>1</sup> Derating may apply

## CONTROL AND STATUS SIGNALS

Input Signals			
PERSON_L			
Active LOW signal which enables/disables the main output. Pulling this signal LOW will turn-on the main output. Recommended pull-up resistor to 12 VSB is 8.2 k with a 3.0 k pull-down to ground. A 100 pF decoupling capacitor is also recommended.			
		MIN	MAX
V <sub>IL</sub>	Input logic level LOW		0.8 V
V <sub>IH</sub>	Input logic level HIGH	2.0 V	5.0 V
I <sub>SOURCE</sub>	Current that may be sourced by this pin		2 mA
I <sub>SINK</sub>	Current that may be sunk by this pin at low state		0.5 mA
PSKILL_L			
First break/last mate active LOW signal which enables/disables the main output. This signal will have to be pulled to ground at the system side with a 220 ohm resistor. A 100 pF decoupling capacitor is also recommended.			
		MIN	MAX
V <sub>IL</sub>	Input logic level LOW		0.8 V
V <sub>IH</sub>	Input logic level HIGH	2.0 V	5.0 V
I <sub>SOURCE</sub>	Current that may be sourced by this pin		2 mA
I <sub>SINK</sub>	Current that may be sunk by this pin at low state		0.5 mA

## CONTROL AND STATUS SIGNALS (CONTINUED)

Output Signals			
<b>ACOK</b>			
Signal used to indicate the presence of AC input to the power supply. A logic level HIGH will indicate that the AC input to the power supply is within the operating range while a logic level LOW will indicate that AC has been lost. This is an open collector/drain output. This pin is pulled high by a 1.0 kohm resistor connected to 3.3 V inside the power supply. It is recommended that this pin be connected to a 100 pF decoupling capacitor and pulled down by a 100 kohm resistor.			
		MIN	MAX
V <sub>IL</sub>	Input logic level LOW		0.6 V
V <sub>IH</sub>	Input logic level HIGH	2.0 V	5.0 V
I <sub>SOURCE</sub>	Current that may be sourced by this pin		3.3 mA
I <sub>SINK</sub>	Current that may be sunk by this pin at low state		0.7 mA
<b>PWR_GOOD / PWOK</b>			
Signal used to indicate that main output voltage is within regulation range. The PWR_GOOD signal will be driven HIGH when the output voltage is valid and will be driven LOW when the output falls below the under-voltage threshold. This signal also gives an advance warning when there is an impending power loss due to loss of AC input or system shutdown request. More details in the Timing Section. This is an open collector/drain output. This pin is pulled high by a 1.0 kohm resistor connected to 3.3 V inside the power supply. It is recommended that this pin be connected to a 100 pF decoupling capacitor and pulled down by a 10 kohm resistor.			
		MIN	MAX
V <sub>IL</sub>	Input logic level LOW		0.8 V
V <sub>IH</sub>	Input logic level HIGH	2.0 V	5.0 V
I <sub>SOURCE</sub>	Current that may be sourced by this pin		3.3 mA
I <sub>SINK</sub>	Current that may be sunk by this pin at low state		0.7 mA
<b>PS_PRESENT_L</b>			
Signal used to indicate to the system that a power supply is inserted in the power bay. This pin is shorted to the standby return in the power supply. Recommended pull-up resistor to 12 VSB is 8.2 k with a 3.0 k pull-down to ground. A 100 pF decoupling capacitor is also recommended.			
<b>PS_INTERRUPT_L</b>			
Active low signal used by the power supply to indicate to the system that a change in power supply status has occurred. This event can be triggered by faults such as OVP, OCP, OTP, and fan fault. This signal can be cleared by a CLEAR_FAULT command. Recommended pull-up resistor to 12 VSB is 8.2 k with a 3.0 k pull-down to ground. A 100 pF decoupling capacitor is also recommended.			
		MIN	MAX
V <sub>IL</sub>	Input logic level LOW		0.8 V
V <sub>IH</sub>	Input logic level HIGH	2.0 V	5.0 V
I <sub>SOURCE</sub>	Current that may be sourced by this pin		4 mA
I <sub>SINK</sub>	Current that may be sunk by this pin at low state		4 mA
BUS Signals			
<b>ISHARE</b>			
Bus signal used by the power supply for active current sharing. All power supplies configured in the system for n+n sharing will refer to this bus voltage in order to load share.			
Voltage Range	The range of this signal for active sharing will be up to 8.0 V, which corresponds to the maximum output current.		
		MIN	MAX
I <sub>SHARE</sub> Voltage	Vshare at 100% load, stand-alone unit	7.75	8.25
	Voltage at 50% load, stand-alone unit	3.85	4.15
	Voltage at 0% load, stand-alone unit	0	0.3
I <sub>SOURCE</sub>	Current that may be sourced by this pin		160 mA
SCL, SDA			
Clock and data signals defined as per I <sup>2</sup> C requirements. It is recommended that these pins be pulled-up to a 2.2 kohm resistor to 3.3 V and a 100 pF decoupling capacitor at the system side.			
VL	Input logic level LOW		0.8 V
VH	Input logic level HIGH	2.0 V	5.0 V

Note: All signal noise levels are below 300 mVpk-pk from 0 - 100 MHz.

I<sup>2</sup>C Addressing Table: Not applicable. This power supply has a fixed I<sup>2</sup>C address. In order to support multiple addresses, the system will have to utilize a switcher or an I<sup>2</sup>C expander.

## ELECTRICAL SPECIFICATIONS

LED Indicators	
A single bi-color LED is used to indicate the power supply status.	
	Status LED
No AC input to PSU	Off when stand-alone, blinking AMBER when in parallel
Main output ON	Solid GREEN
Standby mode or Power supply failure (OCP, OVP, OTP, FAN FAULT)	Blinking AMBER

Firmware Reporting and Monitoring			
	Accuracy Range		
Output loading	5 to 20%	20 to 50%	50 to 100%
Input voltage	± 5%		
Input current	± 0.55 A fixed error	± 4%	
Input power	± 1.25 W at < 125 W input	± 1.25%	
Output voltage	± 2%		
Output current	0.3 A fixed error	± 2%	
Temperature	± 5 °C on the operating range		
E <sub>IN</sub>	± 15% from 10% to 20% load	± 5%	
Fan speed	Actual RPM ± 250 RPM		

PMBus	YES
Remote ON/OFF	YES
Over-current limit trimming	YES

Timing Specifications				
	Description	Min	Max	Unit
T <sub>sb_On</sub>	Delay from AC being applied to standby output being within regulation	20	1700	ms
T <sub>sb_ACOK</sub>	Delay from standby output to ACOK assertion	See note below	20	ms
T <sub>sb_Vout</sub>	Delay from standby output to main output voltage being within regulation		300	ms
T <sub>AC_On_Delay</sub>	Delay from AC being applied to main output being within regulation		2000	ms
T <sub>PWOK_On</sub>	Delay from output voltages within regulation limits to PWOK asserted	100	1000	ms
T <sub>ACOK_Delay</sub>	Delay from loss of AC to assertion of ACOK		6	ms
T <sub>PWR_GOOD_Hold-up</sub>	Delay from loss of AC to deassertion of PWOK	10		ms
T <sub>Vout_Hold-up</sub>	Delay from loss of AC to main output being within regulation	11		ms
T <sub>sb_Hold-up</sub>	Delay from loss of AC to standby output being within regulation	150		ms
T <sub>PWR_GOOD_Off</sub>	Delay from deassertion of PWOK to output falling out of regulation	1		ms
T <sub>PSON_On_Delay</sub>	Delay from PSON assertion to output being within regulation		350	ms
T <sub>PWOK_Low</sub>	Duration of PWOK being in deasserted state during an ON/OFF cycle of PSU	N/A	N/A	

Note: T<sub>Vout\_hold-up</sub>: tested at 1A load on standby output  
T<sub>sb\_ACOK</sub>: ACOK can assert earlier than the standby output

TIMING DIAGRAM

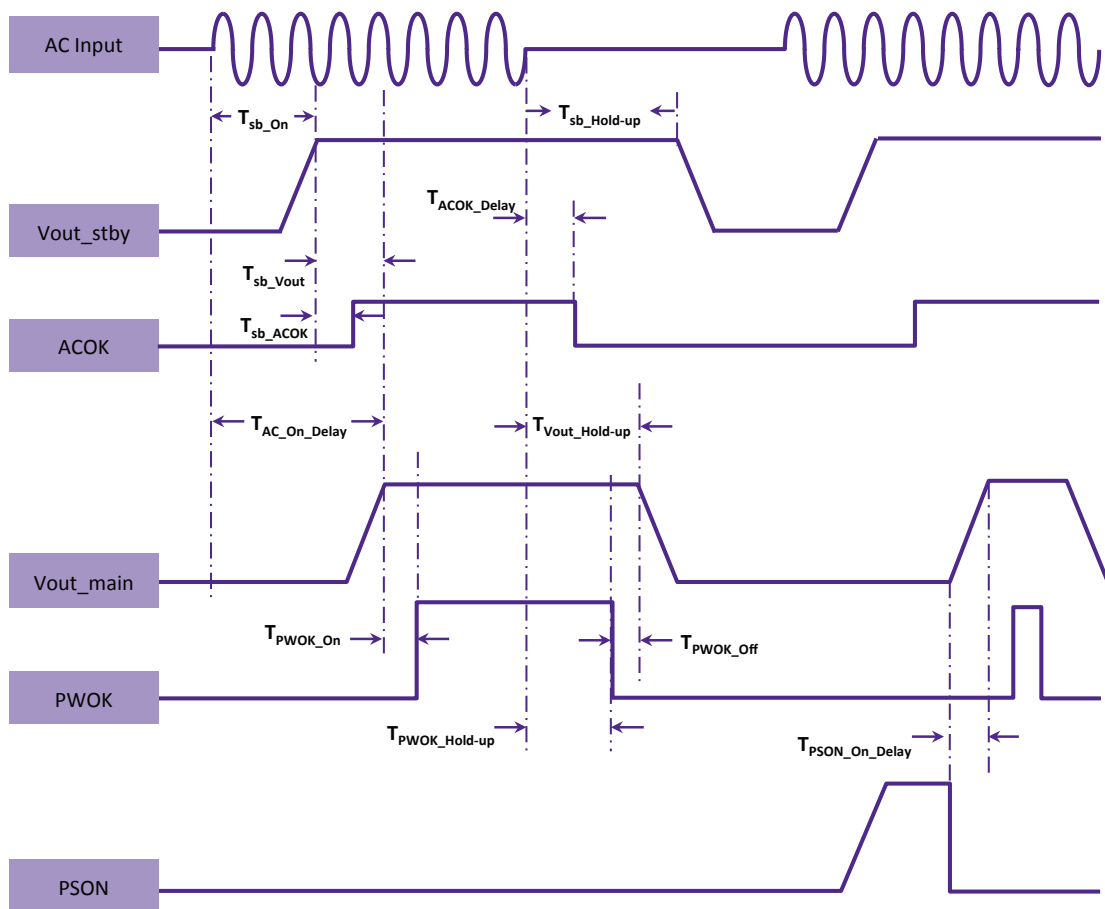

MECHANICAL OUTLINE

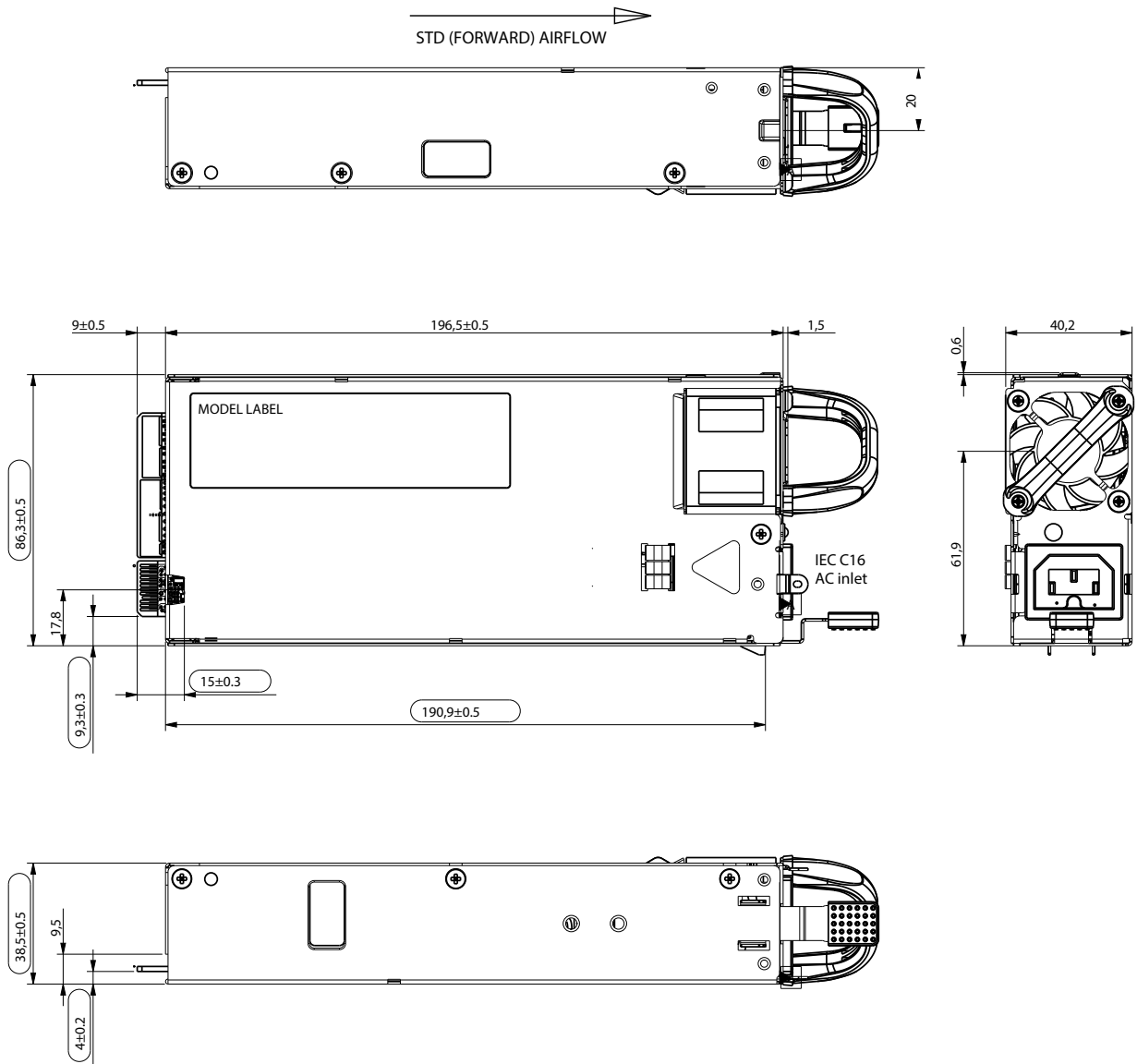

**CONNECTOR DEFINITIONS**

Output Connector Part Number	Card-edge
Mating Connector Part Number	FCI 10107844-002LF or equivalent

Power Supply Output Card Edge (Bottom Side)

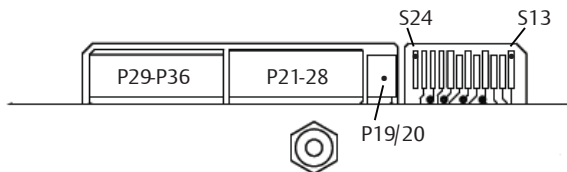

Power Supply Output Card Edge (Top Side)

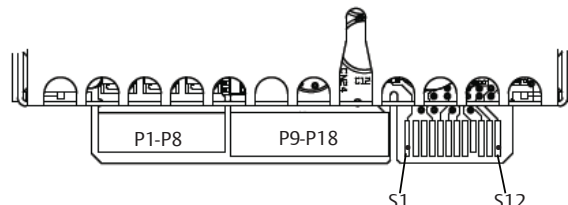

Output Connector Pin Configuration			
S1	PS PRESENT	S13	PS_ON
S2	Reserved	S14	PS_KILL
S3	Reserved	S15	Reserved
S4	Pwr_Good	S16	RTN
S5	ACOK (AC Input Present)	S17	SDA
S6	RTN	S18	RTN
S7	I-SHARE	S19	SCL
S8	RESERVE	S20	RTN
S9	PS INTERRUPT_L	S21	REMOTE SENSE-
S10	RTN	S22	RTN
S11	Reserved	S23	REMOTE SENSE+
S12	Reserved	S24	RESERVE
P1-P8	Vo	P19-P20	VSB
P9-P18	RTN	P21-P28	RTN
		P29-P36	Vo

**ENVIRONMENTAL SPECIFICATIONS**

Operating temperature	0 to 50 °C, refer to power derating curve for operation up to 65 °C
Operating altitude	up to 10,000 feet, CCC claims exemption for 5000 m
Operating relative humidity	20% to 80% non-condensing, non-tropical climate
Non-operating temperature	-40 to +70 °C
Non-operating relative humidity	10% to 95% non-condensing
Non-operating altitude	up to 50,000 feet
Vibration and shock	Standard operating/non-operating shock/vibration
ROHS compliance	YES
MTBF	200,000 hours per Telcordia Issue 2, Method 1, Case 3 at 25 °C ambient at full load
Operating life	Minimum of 5 years
Reliability	All electronic component derating analysis is done at maximum ambient, 80% of maximum rated load, nominal input line voltage.



For international contact information,  
visit [advancedenergy.com](http://advancedenergy.com).

[powersales@aei.com](mailto:powersales@aei.com) (Sales Support)  
[productsupport.ep@aei.com](mailto:productsupport.ep@aei.com) (Technical Support)  
+1 888 412 7832

## ABOUT ADVANCED ENERGY

Advanced Energy (AE) has devoted more than three decades to perfecting power for its global customers. AE designs and manufactures highly engineered, precision power conversion, measurement and control solutions for mission-critical applications and processes.

Our products enable customer innovation in complex applications for a wide range of industries including semiconductor equipment, industrial, manufacturing, telecommunications, data center computing, and medical. With deep applications know-how and responsive service and support across the globe, we build collaborative partnerships to meet rapid technological developments, propel growth for our customers, and innovate the future of power.

PRECISION | POWER | PERFORMANCE

---

Specifications are subject to change without notice. Not responsible for errors or omissions. ©2021 Advanced Energy Industries, Inc. All rights reserved. Advanced Energy®, AE® and Artesyn™ are U.S. trademarks of Advanced Energy Industries, Inc.

## Looking for pricing, stock, or lifecycle information?

Click below to explore more details on WIN SOURCE:

- ⊖ [View DS1100PED-3-001 on WIN SOURCE](#)
- ⊖ [Artesyn Embedded Technologies Information](#)

## Optimize Your Supply Chain with WIN SOURCE Solutions

- ✓ Global Sourcing Solution
- ✓ Obsolete Management
- ✓ Cost Control Management
- ✓ Shortage Management
- ✓ Alternative Solution
- ✓ Excess Inventory Management