

JW-XX-XX-XX-X-XXX-XXX-XX-X

No OF POSITIONS
-02 THRU -24

LEAD STYLE
-04: T-1S8-05-X-05: T-1S8

PLATING SPECIFICATION
-T: MATTE TIN CONTACT AND TAIL
-TM: MATTE TIN CONTACT AND TAIL

OPTION

-P: PICK & PLACE PAD
(USE PPP-47, SEE FIG. 2, SHEET 2)
(-VS ONLY, 3 POSITION MIN,
.275[6.99] MIN POST HEIGHT)

OPTION

-VS: VERTICAL SURFACE MOUNT

POST HEIGHT

-XXX: SPECIFY POST HEIGHT
.000 MIN (SEE NOTE 3)

SPACE OPTION

-XXX: SPECIFY BOARD SPACING

ROW SPECIFICATION

-S: SINGLE (USE HFWJ-24-156)

DO NOT
SCALE FROM
THIS PRINT

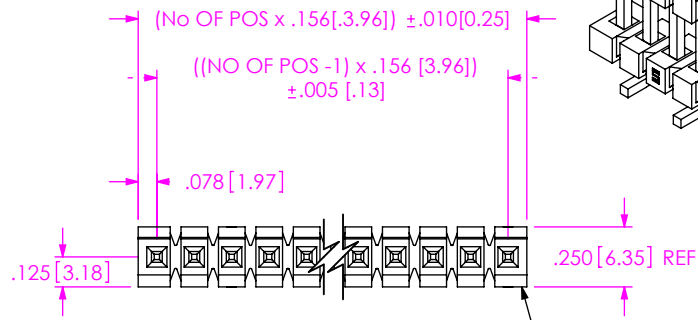
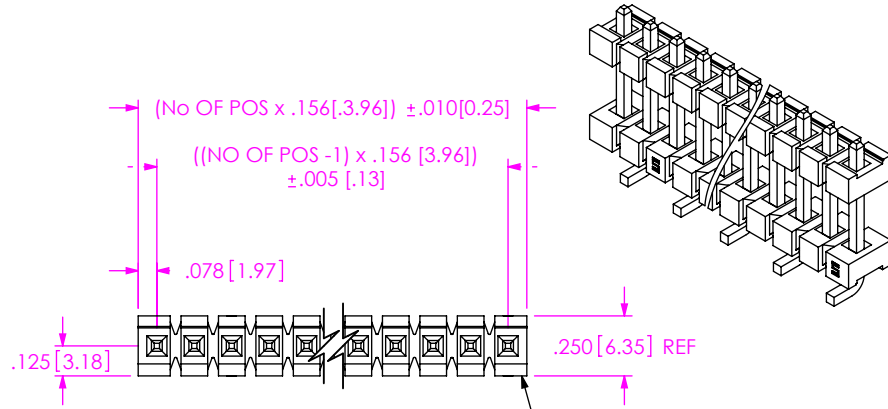

-S: SINGLE

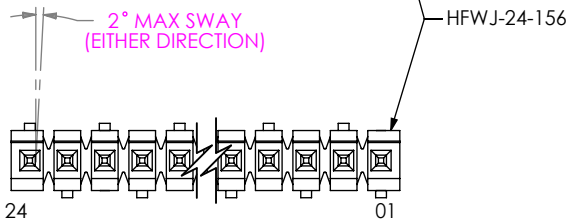

-VS: VERTICAL SURFACE MOUNT

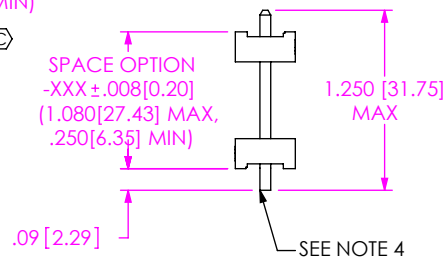
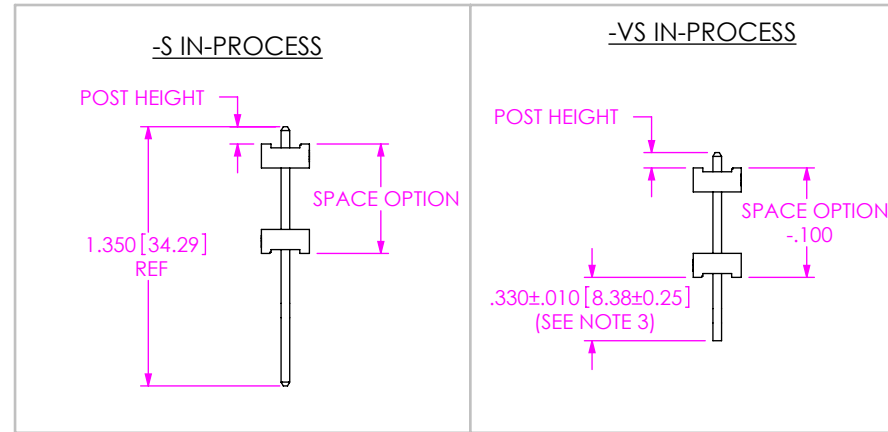
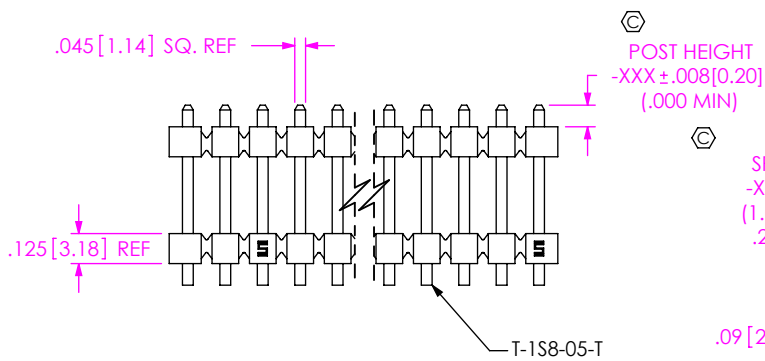

-S: SINGLE

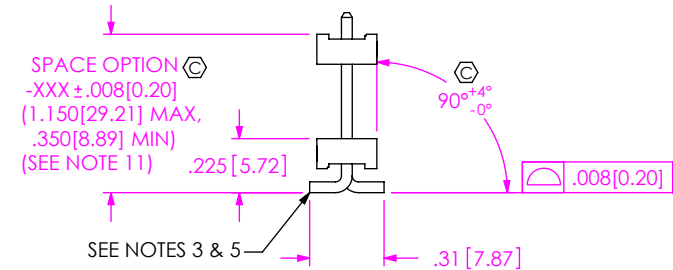

-VS: VERTICAL SURFACE MOUNT

NOTES:

- HEIGHT VARIATION BETWEEN ANY TWO PINS SHALL BE .010[0.25] MAX.
- MAXIMUM PIN ROTATION IN BODY: 2°.
- SHEARING IS NOT NECESSARY IF DIMENSION IS BELOW .340[8.64] AT FILL.
- MAXIMUM BURR ALLOWED: .004[0.10].
- MAXIMUM BURR ALLOWED: .0015[0.038].
- THROUGH HOLE TO BE BULK PACKAGED.
- VERTICAL SURFACE MOUNT (-VS) TO BE PACKAGED AS FOLLOWS:
POSITIONS -04 THRU -24 ARE TO BE PACKAGED IN TUBES (SEE TABLE 1, SHEET 2);
POSITIONS -02 AND -03 ARE TO BE LAYER PACKAGED.
- MIN PUSHOUT FORCE TO BE 3 LBS.
- MAX CUT FLASH TO BE .020[0.51].
- ⊙ REPRESENTS A CRITICAL DIMENSION.
- MEASURE AT END OF BEND RADIOUS.

UNLESS OTHERWISE SPECIFIED, DIMENSIONS ARE IN INCHES.
TOLERANCES ARE:
DECIMALS ANGLES
.XX: ±.01 [.3] 2°
.XXX: ±.005 [.13]
.XXXX: ±.0020 [.051]

PROPRIETARY NOTE

THIS DOCUMENT CONTAINS CONFIDENTIAL AND PROPRIETARY INFORMATION AND ALL DESIGN, MANUFACTURING, REPRODUCTION, USE, PATENT RIGHTS AND SALES RIGHTS ARE EXPRESSLY RESERVED BY SAMTEC, INC. THIS DOCUMENT SHALL NOT BE DISCLOSED, IN WHOLE OR PART, TO ANY UNAUTHORIZED PERSON OR ENTITY NOR REPRODUCED, TRANSFERRED OR INCORPORATED IN ANY OTHER PRODUCT IN ANY MANNER WITHOUT THE EXPRESS WRITTEN CONSENT OF SAMTEC, INC.



520 PARK EAST BLVD, NEW ALBANY, IN 47150
PHONE: 812-944-6733 FAX: 812-948-5047
e-Mail: info@SAMTEC.com code: 55322

MATERIAL: DO NOT SCALE DRAWING SHEET SCALE: 1:25:1

INSULATOR: LCP, COLOR: NATURAL
TERMINAL: PHOSPHOR BRONZE

MAX BOW ALLOWED: .002[0.05] IN/IN

F:\DWG\MISC\MKTG\JW-XX-XX-XX-X-XXX-XXX-XX-X-MKT.SLDRW

DESCRIPTION: .156[3.96] POWER STACKER ASSEMBLY

DWG. NO. JW-XX-XX-XX-X-XXX-XXX-XX-X

BY: KEVIN B 06/12/2002 SHEET 1 OF 2

FIG 2
 -P: PICK & PLACE PAD OPTION
 (-VS ONLY, 3 POS. MIN)

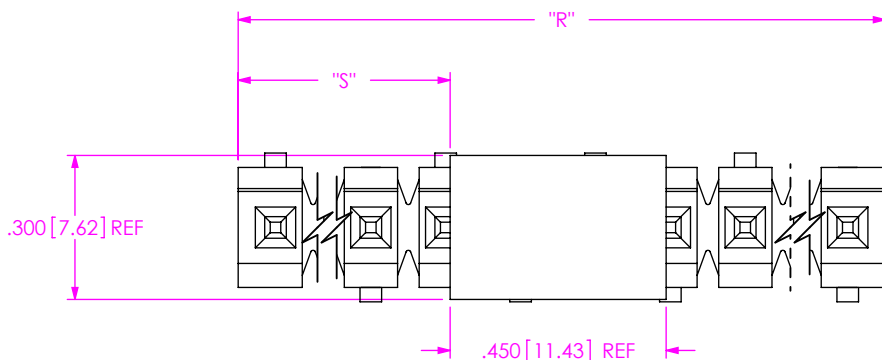

NOTE:
 "R" = No OF POS x .156[3.96] REF
 "S" = $\{("R" - .450[11.43]) / 2\} \pm .020[12.90]$
 "G" = POST HEIGHT (.275[6.99] MIN) + .050[1.27] REF

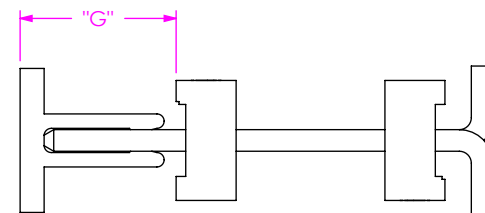

TABLE 1 (SEE NOTE 7)		
SPACE OPTION + POST HEIGHT	PACKAGING TUBE	PLUG
.350 TO .725 [8.89 TO 18.42]	PT-1-24-16-29	TP-07
.350 TO .725 [8.89 TO 18.42](w/-P)	PT-1-24-01-67	TP-13
.726 TO .890 [18.44 TO 22.61]	PT-1-24-01-67	TP-13
.891 TO 1.125 [22.61 TO 28.58]	PT-HPW001-P	TP-26
1.126 TO 1.240 [28.60 TO 31.50]	PT-24-01-104	TP-26

PROPRIETARY NOTE
 THIS DOCUMENT CONTAINS CONFIDENTIAL AND PROPRIETARY INFORMATION AND ALL DESIGN, MANUFACTURING, REPRODUCTION, USE, PATENT RIGHTS AND SALES RIGHTS ARE EXPRESSLY RESERVED BY SAMTEC, INC. THIS DOCUMENT SHALL NOT BE DISCLOSED, IN WHOLE OR PART, TO ANY UNAUTHORIZED PERSON OR ENTITY NOR REPRODUCED, TRANSFERRED OR INCORPORATED IN ANY OTHER PROJECT IN ANY MANNER WITHOUT THE EXPRESS WRITTEN CONSENT OF SAMTEC, INC.

DO NOT SCALE DRAWING

SHEET SCALE: 2.5:1



520 PARK EAST BLVD, NEW ALBANY, IN 47150
 PHONE: 812-944-6733 FAX: 812-948-5047
 e-Mail: info@SAMTEC.com code: 55322



DESCRIPTION:
 .156[3.96] POWER STACKER ASSEMBLY

DWG. NO.
 JW-XX-XX-XX-X-XXX-XXX-XX-X

BY: KEVIN B 06/12/2002 SHEET 2 OF 2

Looking for pricing, stock, or lifecycle information?

Click below to explore more details on WIN SOURCE:

-  [View JW-11-04-T-S-1130-140 on WIN SOURCE](#)
-  [Samtec Inc. Information](#)

Optimize Your Supply Chain with WIN SOURCE Solutions

-  Global Sourcing Solution
-  Obsolete Management
-  Cost Control Management
-  Shortage Management
-  Alternative Solution
-  Excess Inventory Management