



**THE DATASHEET OF
VSC8489YJU-02**



VSC8489-02 Datasheet
Dual Channel WAN/LAN/Backplane RXAUI/XAUI to
SFP+/KR 10 GbE SerDes PHY



a  MICROCHIP company



Microsemi Headquarters

One Enterprise, Aliso Viejo,
CA 92656 USA

Within the USA: +1 (800) 713-4113

Outside the USA: +1 (949) 380-6100

Sales: +1 (949) 380-6136

Fax: +1 (949) 215-4996

Email: sales.support@microsemi.com

www.microsemi.com

©2018 Microsemi, a wholly owned subsidiary of Microchip Technology Inc. All rights reserved. Microsemi and the Microsemi logo are registered trademarks of Microsemi Corporation. All other trademarks and service marks are the property of their respective owners.

Microsemi makes no warranty, representation, or guarantee regarding the information contained herein or the suitability of its products and services for any particular purpose, nor does Microsemi assume any liability whatsoever arising out of the application or use of any product or circuit. The products sold hereunder and any other products sold by Microsemi have been subject to limited testing and should not be used in conjunction with mission-critical equipment or applications. Any performance specifications are believed to be reliable but are not verified, and Buyer must conduct and complete all performance and other testing of the products, alone and together with, or installed in, any end-products. Buyer shall not rely on any data and performance specifications or parameters provided by Microsemi. It is the Buyer's responsibility to independently determine suitability of any products and to test and verify the same. The information provided by Microsemi hereunder is provided "as is, where is" and with all faults, and the entire risk associated with such information is entirely with the Buyer. Microsemi does not grant, explicitly or implicitly, to any party any patent rights, licenses, or any other IP rights, whether with regard to such information itself or anything described by such information. Information provided in this document is proprietary to Microsemi, and Microsemi reserves the right to make any changes to the information in this document or to any products and services at any time without notice.

About Microsemi

Microsemi, a wholly owned subsidiary of Microchip Technology Inc. (Nasdaq: MCHP), offers a comprehensive portfolio of semiconductor and system solutions for aerospace & defense, communications, data center and industrial markets. Products include high-performance and radiation-hardened analog mixed-signal integrated circuits, FPGAs, SoCs and ASICs; power management products; timing and synchronization devices and precise time solutions, setting the world's standard for time; voice processing devices; RF solutions; discrete components; enterprise storage and communication solutions, security technologies and scalable anti-tamper products; Ethernet solutions; Power-over-Ethernet ICs and midspans; as well as custom design capabilities and services. Learn more at www.microsemi.com.

Contents

1	Revision History	1
1.1	Revision 4.1	1
1.2	Revision 4.0	1
1.3	Revision 2.0	1
2	Overview	2
2.1	Major Applications	3
2.2	Features and Benefits	4
3	Functional Descriptions	5
3.1	Data Path Overview	5
3.1.1	Ingress Operation	5
3.1.2	Egress Operation	6
3.1.3	Interface Data Rates	6
3.2	Physical Medium Attachment (PMA)	7
3.2.1	VScope Input Signal Monitoring Integrated Circuit	7
3.3	WAN Interface Sublayer (WIS)	8
3.3.1	Operation	9
3.3.2	Section Overhead	11
3.3.3	Line Overhead	17
3.3.4	SPE Pointer	22
3.3.5	Path Overhead	25
3.3.6	Defects and Anomalies	31
3.3.7	Interrupt Pins and Interrupt Masking	32
3.3.8	Overhead Serial Interfaces	33
3.3.9	Pattern Generator and Checker	36
3.4	10G Physical Coding Sublayer (64B/66B PCS)	37
3.4.1	Control Codes	37
3.4.2	Transmit Path	38
3.4.3	Receive Path	38
3.4.4	PCS Standard Test Modes	39
3.5	1G Physical Coding Sublayer	40
3.6	Rate Compensating Buffers	40
3.7	Loopback	40
3.8	Cross-Connect (Non-Hitless Operation)	41
3.9	Host-Side Interface	43
3.9.1	RXAUI Interoperability	44
3.10	Clocking	44
3.10.1	PLL	44
3.10.2	Reference Clock	45
3.10.3	Synchronous Ethernet Support	46
3.11	Operating Modes	46
3.11.1	10G LAN	46
3.11.2	10G WAN	46
3.11.3	1 GbE	47
3.12	Management Interfaces	47
3.12.1	MDIO Interface	48
3.12.2	SPI Slave Interface	49
3.12.3	Two-Wire Serial (Slave) Interface	52
3.12.4	Two-Wire Serial (Master) Interface	54
3.12.5	GPIO	54

3.12.6	JTAG	56
4	Registers	58
5	Electrical Specifications	59
5.1	DC Characteristics	59
5.1.1	DC Inputs and Outputs	59
5.1.2	Reference Clock	60
5.2	AC Characteristics	60
5.2.1	Receiver Specifications	60
5.2.2	Transmitter Specifications	64
5.2.3	Timing and Reference Clock	68
5.2.4	Two-Wire Serial (Slave) Interface	69
5.2.5	MDIO Interface	70
5.2.6	SPI Slave Interface	71
5.3	Operating Conditions	73
5.4	Stress Ratings	73
6	Pin Descriptions	75
6.1	Pin Diagram	75
6.2	Pin Identifications	75
6.3	Pins by Function	76
7	Package Information	91
7.1	Package Drawing	91
7.2	Thermal Specifications	92
7.3	Moisture Sensitivity	93
8	Design Considerations	94
8.1	Low-power mode and SerDes calibration	94
8.2	Low-power mode should not be enabled when failover switching is enabled	94
8.3	Flow control with failover switching	94
8.4	XAUI BIST Checker Compatibility	94
8.5	SPI bus speeds	94
8.6	GPIO as TOSI	94
8.7	10GBASE-KR auto negotiation and training	94
8.8	Loopbacks in 10G WAN mode	94
8.9	10/100M mode not supported	94
8.10	Limited access to registers during failover cross-connect mode	95
8.11	Limited auto negotiation support in 1G mode	95
8.12	Limited 1G status reporting	95
8.13	RXCKOUT squelching	95
9	Ordering Information	96

Figures

Figure 10	VSC8489-02 Block Diagram	3
Figure 11	SFP/SFP+ Application	4
Figure 12	Backplane Equalization Application	4
Figure 13	10GBASE-KR Output Driver	8
Figure 14	KR Test Pattern	8
Figure 15	WIS Transmit and Receive Functions	9
Figure 16	WIS Frame Structure	10
Figure 17	STS-192c/STM-64 Section and Line Overhead Structure	10
Figure 18	Path Overhead Octets	11
Figure 19	Primary Synchronization State Diagram	13
Figure 20	Secondary Synchronization State Diagram	14
Figure 21	16-bit Designations within Payload Pointer	23
Figure 22	Pointer Interpreter State Diagram	24
Figure 23	TOSI Timing Diagram	34
Figure 24	ROSI Timing Diagram	36
Figure 25	PCS Block Diagram	37
Figure 26	64B/66B Block Formats	39
Figure 27	Host-Side and Line-Side Loopbacks	41
Figure 28	Cross-Connect Configuration	43
Figure 29	Host-Side I/O Interface	44
Figure 30	10G LAN	46
Figure 31	10G WAN	47
Figure 32	1 GbE	47
Figure 33	SPI Single Register Read	50
Figure 34	SPI Multiple Register Reads	50
Figure 35	SPI Multiple Register Writes	50
Figure 36	SPI Read Following Write	50
Figure 37	SPI Write Following Read	50
Figure 38	SPI Slave Default Mode	51
Figure 39	SPI Slave Fast Mode	51
Figure 40	Two-Wire Serial Bus Reset Sequence	52
Figure 41	Two-Wire Serial Slave Register Address Format	52
Figure 42	Two-Wire Serial Write Instruction	53
Figure 43	Two-Wire Serial Read Instruction	53
Figure 44	SFI Datacom Sinusoidal Jitter Tolerance	61
Figure 45	XAUI Receiver Input Sinusoidal Jitter Tolerance	63
Figure 46	SFI Transmit Differential Output Compliance Mask	65
Figure 47	XAUI Output Compliance Mask	67
Figure 48	XREFCK to Data Output Jitter Transfer	69
Figure 49	Two-Wire Serial Interface Timing	70
Figure 50	Timing with MDIO Sourced by STA	71
Figure 51	Timing with MDIO Sourced by MMD	71
Figure 52	SPI Interface Timing	72
Figure 53	3-Pin Push-Out SPI Timing	73
Figure 54	Pin Diagram	75
Figure 55	Package Drawing	92

Tables

Table 56	Interface Data Rates	6
Table 57	Section Overhead	11
Table 58	Framing Parameter Description and Values	13
Table 59	Line Overhead Octets	17
Table 60	K2 Encodings	20
Table 61	SONET/SDH Pointer Mode Differences	22
Table 62	H1/H2 Pointer Types	23
Table 63	Concatenation Indication Types	23
Table 64	Pointer Interpreter State Diagram Transitions	24
Table 65	STS Path Overhead Octets	25
Table 66	Path Status (G1) Byte for RDI-P Mode	28
Table 67	Path Status (G1) Byte for ERDI-P Mode	28
Table 68	RDI-P and ERDI-P Bit Settings and Interpretation	28
Table 69	PMTICK Counters	30
Table 70	Defects and Anomalies	31
Table 71	TOSI/ROSI Addresses	34
Table 72	Control Codes	37
Table 73	Host-Side Loopbacks	40
Table 74	Line-Side Loopbacks	41
Table 75	Failover and Broadcasting Modes	42
Table 76	RXAUI Interoperability	44
Table 77	Supported Reference Clock Frequencies	44
Table 78	XREFCK Frequency Selection	45
Table 79	Supported Clock Rates and Modes	45
Table 80	MDIO Port Addresses Per Channel	48
Table 81	SPI Slave Instruction Bit Sequence	49
Table 82	GPIO Functions	54
Table 83	JTAG Instructions and Register Codes	57
Table 84	LVTTL Input and Push/Pull Output DC Characteristics	59
Table 85	LVTTLOD Input and Open-Drain Output DC Characteristics	59
Table 86	Reference Clock DC Characteristics	60
Table 87	Line-Side 10G Receiver Input (SFI Point D 9.95328G) AC Characteristics	60
Table 88	Line-Side SONET 10G Input Jitter AC Characteristics	62
Table 89	Host-Side RXAUI Receiver AC Characteristics	62
Table 90	Host-Side XAUI Receiver AC Characteristics	62
Table 91	Line-Side 1.25 Gbps SFI Input AC Characteristics	63
Table 92	Host-Side 1.25 Gbps (1000BASE-KX) Receiver Input AC Characteristics	64
Table 93	Line-Side 10G Transmitter Output (SFI Point B) AC Characteristics	64
Table 94	Transmitter SFP+ Direct Attach Copper Output AC Characteristics	65
Table 95	10 Gbps Transmitter 10GBASE-KR AC Characteristics	65
Table 96	Line-Side SONET 10G Output Jitter AC Characteristics	66
Table 97	Near-end RXAUI Transmitter Output AC Characteristics	66
Table 98	Far-end RXAUI Transmitter Output AC Characteristics	66
Table 99	Far-end XAUI Transmitter Output AC Characteristics	67
Table 100	Line-Side 1.25 Gbps SFI Output AC Characteristics	68
Table 101	Host-Side Transmitter 1000BASE-KX AC Characteristics	68
Table 102	Reference Clock AC Characteristics	68
Table 103	Two-Wire Serial Interface AC Characteristics	69
Table 104	MDIO Interface AC Characteristics	70
Table 105	Clock Output AC Characteristics	71
Table 106	SPI Slave Interface AC Characteristics	71
Table 107	3-Pin Push-Out SPI AC Characteristics	72
Table 108	Recommended Operating Conditions	73
Table 109	Stress Ratings	73
Table 110	Pin Identifications	76

Table 111	Thermal Resistances	93
Table 112	Ordering Information	96

1 Revision History

The revision history describes the changes that were implemented in the document. The changes are listed by revision, starting with the most current publication.

1.1 Revision 4.1

Revision 4.1 was published in September 2018. In revision 4.1 of this document, the registers were attached. For more information, see [Registers](#), page 58.

1.2 Revision 4.0

Revision 4.0 was published in November 2017. The following is a summary of the changes in revision 4.0 of this document.

- Low-voltage transistor-to-transistor logic (LVTTTL) updated to low-voltage transistor-to-transistor logic with open-drain output (LVTTLOD) where appropriate.
- The two-wire serial slave interface register address illustrations and 24-bit addressing scheme details were updated. For more information, see [Two-Wire Serial \(Slave\) Interface](#), page 52.
- Line-side 10G receiver input AC characteristics were updated. For more information, see [Table 32](#), page 60.
- Conditions for transmitter SFP+ direct attach copper output AC characteristics were updated. For more information, see [Table 39](#), page 65.
- Reference clock AC characteristics were updated. For more information, see [Table 47](#), page 68.
- The SPI interface timing diagram was updated. For more information, see [Figure 43](#), page 72.
- Some pin description information was updated. For more information, see [Pins by Function](#), page 76.
- Moisture sensitivity level (MSL) was corrected from 2 to 4. For more information, see [Moisture Sensitivity](#), page 93.

1.3 Revision 2.0

Revision 2.0 was published in September 2017. It was the first publication of this document.

2 Overview

The VSC8489-02 device is a dual-port 10G/1G WAN/LAN/Backplane RXAUI/XAUI to SFP+/KR 10 GbE SerDes PHY. It supports IEEE 802.3ae.

The VSC8489-02 is a dual-channel device for timing-critical applications. It is also well suited for optical module, copper Twinax cable, and backplane applications with support for a wide variety of protocols, including 10 GbE LAN, 10 Gb WAN, and 1 Gb Legacy Ethernet.

The VSC8489-02 device meets the SFP+ limiting and linear SR/LR/ER/ZR/220MMF host requirements in accordance with the SFF-8431 specifications. It also compensates for electrical and optical impairments in SFP+ applications, along with imperfections of the PCB and connectors.

The VSC8489-02 device provides a complete suite of BIST functionality, including line and client loopbacks, along with pattern generation and error detection. Highly flexible clocking options support LAN and WAN operation using single 156.25 MHz reference clock rate inputs for seamless Synchronous Ethernet support. The VSC8489-02 device also includes a failover switching capability for protection routing, along with selectable lane ordering.

The serial side supports 1.25 Gbps and various 10 Gbps modes. Each channel consists of a receiver (Rx) and a transmitter (Tx) subsection. Three programmable reference clock inputs (XREFCK, SREFCK, and WREFCK) support the various modes along with clock and data recovery (CDR) in the Rx and Tx subsections of all channels.

The following illustration shows a high-level block diagram for the VSC8489-02 device.

Figure 1 • VSC8489-02 Block Diagram

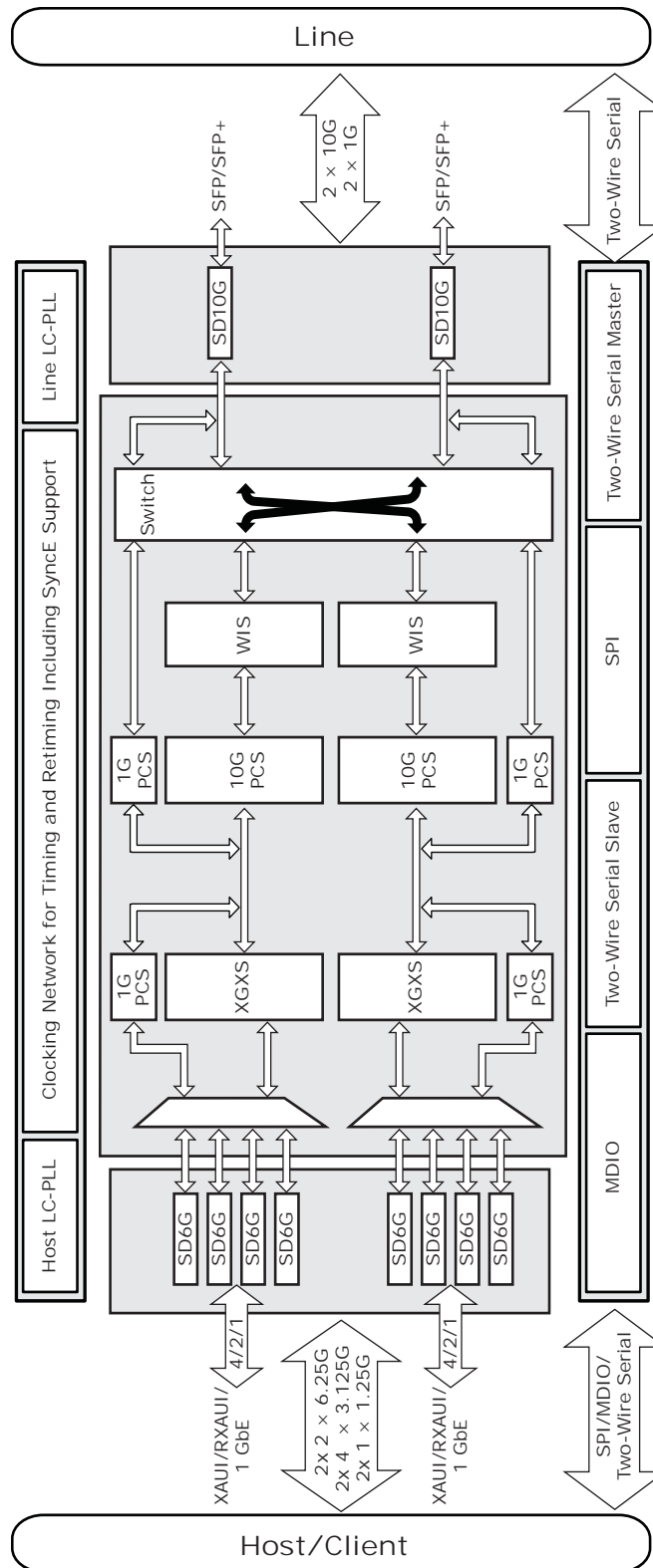

2.1 Major Applications

- Multiple-port RXAUJ/XAUJ to SFI/SFP+ line cards or network interface controllers

- Carrier Ethernet networks
- Secure data center-to-data center interconnects
- 10 GbE switch cards, router cards, and NICs

The following illustrations show the various applications for the VSC8489-02 device.

Figure 2 • SFP/SFP+ Application

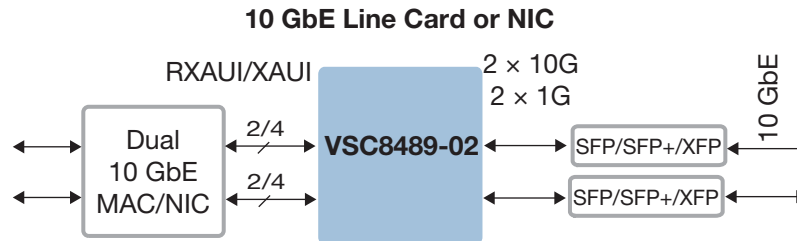
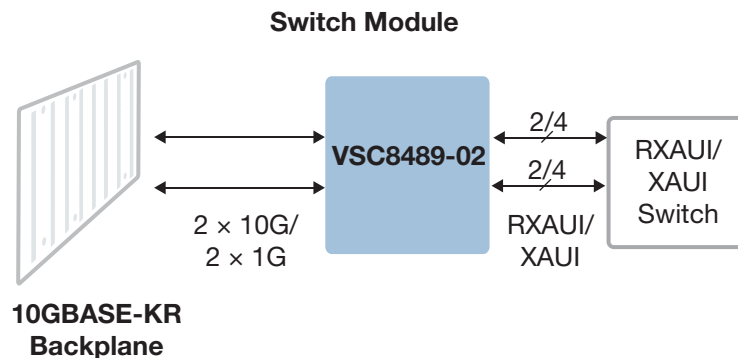

Figure 3 • Backplane Equalization Application



2.2 Features and Benefits

The main features of the VSC8489-02 device are as follows:

- Compliant to IEEE 802.3ae and SFF-8431 electrical (SFI) specifications
- 9.95 Gbps WAN, 10.3125 Gbps LAN, and 1.25 Gbps Ethernet support
- Supports all standard SFP+ applications
- Adaptive receive equalization with programmable, multitap transmit pre-emphasis
- Extended WIS support
- MDIO, SPI, and two-wire serial slave management interfaces
- Failover switching for protection routing, along with selectable lane ordering (non-hitless switching)
- VScope™ input signal monitoring integrated circuit
- Host-side and line-side loopbacks with BIST functions
- I/O programmability for lane swap, invert, amplitude, slew, pre-emphasis, and equalization
- Optional forward error correction (FEC)
- Flexible clocking options for Synchronous Ethernet support
- Passive copper cable compliant to SFF-8431 is supported for minimum transmission cost
- Pin-friendly with VSC8488

3 Functional Descriptions

This section describes the functional aspects of the VSC8489-02 device, including the functional block diagram, operating modes, and major functional blocks.

The VSC8489-02 device host-side interface is either four-lane XAUI, two-lane RXAUI, or one-lane 1 GbE. The line-side interface is 10G SFP+ or 1 GbE SFP.

Each lane has the following main sections:

- **PMA**
The PMA section contains the high-speed serial I/O interfaces, an input equalization circuit, a KR-compliant output buffer, and a SerDes. Additionally, the PMA also generates all the line-side clocks, including the clocks required for Synchronous Ethernet applications.
- **WIS**
The WIS section contains the framing and de-framing circuits and control and status registers to convert the data to be IEEE 802.3ae WIS-compliant.
- **10G PCS**
The 10G PCS section is composed of the PCS transmit, PCS receive, block synchronization, and BER monitor processes. The PCS functions can be further broken down into encode or decode, scramble or descramble, and gearbox functions, as well as various test and loopback modes.
- **1G PCS**
The 1G PCS section describes the 1000BASE-X/SGMII coding and auto-negotiation processes. There are two instances per channel, one for the host and one for the line.
- **FIFO**
The FIFO section contains a rate-compensating FIFO between the line rate and the host rate.
- **Cross Connect**
The cross connect connects one port to the adjacent port to enable routing data/clock to and from port 1 and 0. This cross connect only supports broadcasting from PMA to XAUI but NOT from XAUI to PMA. The failover supported by this cross connect is not hitless.
- **XGXS**
The XGXS implements the PHY XGXS referenced in IEEE 802.3 Clause 47, and contains a 10GBASE-X PCS as defined in Clause 48. It provides the necessary translation between the external XAUI interface and the on-chip XGMII interface. In addition to standard 4-lane XAUI, it also supports 2-lane RXAUI/DDR-XAUI.
- **XAUI/RXAUI**
The XAUI and RXAUI section contains the parallel XAUI/RXAUI I/O interface and a SerDes.
- **KR**
The KR driver includes programmable equalization accomplished by a three-tap finite impulse response (FIR) structure. Three-tap delays are achieved by three flip-flops clocked by a high-speed serial clock (10 GHz in 10G mode; 1 GHz in 1G mode).
- **Loopback**
The loopback sections describe the different loopbacks available in the VSC8489-02 device, including system and network loopbacks. The various loopbacks enhance the engineering debugging and manufacturing testing capability.
- **Management**
The management section contains the status and configuration registers and the serial management interface logic to access them.

3.1 Data Path Overview

The following sections provide data path information for the VSC8489-02 device. Ingress and egress data flow is relative to the line-side interface.

3.1.1 Ingress Operation

Data is received by the line-side interface (SFP+/1 GbE), processed by core logic, and transmitted from the host-side interface (XAUI/RXAUI/1 GbE) in the ingress (or line-side receive) data path.

High-speed serial data is received by the PMA. Data can be equalized and is delivered to the clock recovery unit (CRU). The received serial data must be a 66B/64B encoded ethernet frame at 10.3125 Gbps in 10G LAN mode, a SONET/SDH STS-192c frame at 9.953 Gbps in 10G WAN mode, or 8B/10B encoded data at 1.25 Gbps in 1 GbE mode.

In 10G WAN mode, the CRU data is processed by the WIS where 66B/64B encoded ethernet data is extracted from SONET/SDH STS-192c frames and overhead bytes are processed. The extracted payload data is then processed by the 10G PCS. In 10G LAN mode, the CRU data is processed by a 10G PCS. In 1G mode, the CRU data is processed by the line-side 1G PCS.

In 10G LAN and WAN modes, data from the core is 8B/10B encoded by the XGXS logic and serialized in the host-side SerDes. The host interface can be configured as a XAUI interface where four lanes of 3.125 Gbps data is transmitted, or as a RXAUI interface where two lanes of 6.25 Gbps data is transmitted. Data is transmitted on XAUI lanes 0 and 2 when the host interface is configured to be RXAUI.

In 1 GbE mode, data from the core is 8B/10B encoded by the host-side 1G PCS logic and serialized in the host-side SerDes. 1.25 Gbps data is transmitted from the host interface on either XAUI lane 0 or 3. When 1 GbE data is transmitted from XAUI lane 0, data received by the host interface must enter on lane 0. When 1 GbE data is transmitted from XAUI lane 3, data received by the host interface must enter on lane 3.

3.1.2 Egress Operation

Data is received by the host-side interface (XAUI/RXAUI/1 GbE), processed by core logic, and transmitted from the line-side interface (SFP+/1 GbE) in the egress (or line-side transmit) data path.

The host-side interface can be configured to receive XAUI or RXAUI data when in 10G LAN or 10G WAN modes. Data enters the part on XAUI lanes 0 and 2 when using the RXAUI interface. The host-side interface receives 1 GbE data when the VSC8489-02 device is in the 1G operating mode. XAUI lane 0 or lane 3 may be selected to receive the 1.25 Gbps data at the host interface. When receiving data on XAUI lane 0, 1 GbE data will be transmitted from XAUI lane 0 in the ingress data path. When receiving data on XAUI lane 3, 1 GbE data will be transmitted from XAUI lane 3 in the ingress data path.

In 10G mode, a clock is recovered from each lane of XAUI/RXAUI data in the host-side SerDes. The data is 8B/10B decoded and lane aligned in the XGXS logic. The data is then 66B/64B encoded by the 10G PCS logic. The data is serialized by the PMA in 10G LAN mode and transmitted from the line interface at 10.3125 Gbps. When the WIS logic is enabled in 10G WAN mode, a SONET/SDH STS-192c frame is created using the 66B/64B encoded data as the frame's payload. The WIS data is serialized by the PMA and transmitted from the line interface at 9.953 Gbps.

In 1G mode, a clock is recovered from 1 GbE data in the host-side SerDes. The data is 8B/10B decoded by the host-side 1G PCS, then optionally processed by the The data is 8B/10B encoded by the line-side 1G PCS logic, serialized by the PMA, and transmitted from the line interface at 1.25 Gbps.

3.1.3 Interface Data Rates

The following table shows the interface data rates supported by the VSC8489-02 device.

Table 1 • Interface Data Rates

Operating Mode	Line-Side Datarate (Gbps)	Host-Side Interface	Host-Side Datarate (Gbps)
10G LAN	1 × 10.3125	XAUI	4 × 3.125
10G LAN	1 × 10.3125	RXAUI	2 × 6.25
10G WAN	1 × 9.95328	XAUI	4 × 3.125
10G WAN	1 × 9.95328	RXAUI	2 × 6.25
1 GbE	1 × 1.25	1 GbE	1 × 1.25

3.2 Physical Medium Attachment (PMA)

The VSC8489-02 PMA section consists of a receiver (Rx) and a transmitter (Tx) subsection. The receiver accepts data from the serial data input RXIN and sends the parallel data to the WIS, 10G PCS, or 1G PCS block. A data rate clock also accompanies the parallel data. The transmitter accepts parallel data from the WIS or PCS block and transmits at serial data output TXOUT. A loopback at the data path is also provided, connecting the Rx and the Tx subsection.

Serial data is pre-equalized in the input buffer, and clock and data are recovered in the deserializer, which provides 32-bit data. A demux then deserializes the data into a parallel core data interface. A PLL in the Rx subsection is used as reference for clock and data recovery. Locked to the incoming datastream, a lane sync signal is derived from the PLL clock, which may be used for source synchronous data transmission to one or multiple transmitters.

The Tx subsection is made up of the serializer, the output buffer, and the PLL. The high-speed serial stream is forwarded to a 3-tap filter output buffer. The PLL in the Tx subsection is used to generate the high-speed clock used in the serializer.

To support different data rates, a frequency synthesizer inside the Rx and Tx subsection takes the reference clock input XREFCK and generates all necessary clock rates.

The PMA also has two fully programmable clock outputs, TXCKOUT and RXCKOUT, that may be used to output various clock domains from the PMA. For more information about the reference clock, see [Reference Clock](#), page 45.

3.2.1 VScope Input Signal Monitoring Integrated Circuit

The VScope™ input signal monitoring integrated circuit displays the input signal before it is digitized by the CDR. The two primary configurations are as follows:

- Unity Gain Amplifier monitors the 10 Gbps input signals before signal processing and equalization. VScope input signal monitoring integrated circuit acts as a virtual scope to effectively observe the received data signal before it has been processed. The autonomous adaptive filter taps must first be disabled and the front-end receiver must be set for operation as a linear, unity gain amplifier. In this mode, all DFE taps are set to zero. This mode does not require an adaptive algorithm.
- Link Monitor provides the link margin. VScope input signal monitoring integrated circuit enables design engineers and system developers to monitor signals remotely without disrupting the data integrity of a live data path. By monitoring the health of a given link (optical or electrical), various types of signal degradation can be identified and corrected.

Note: The VScope input signal monitoring integrated circuit feature is only available in the 10G operation mode.

3.2.1.1 10GBASE-KR Output Driver

The high-speed output driver includes programmable equalization accomplished by a three-tap finite impulse response (FIR) structure. The three-tap delays are achieved by three flip-flops clocked by a high-speed serial clock, as shown in the following illustration. Coefficients $C(-1)$, $C(0)$ and $C(+1)$ adjust the pre-cursor, main-cursor, and post-cursor of the output waveform. The coefficients are independently adjusted by control bits. The bits for each coefficient are decoded in a thermometer fashion to achieve linear coefficient adjustment. The three delayed data streams, after being properly strength adjusted by their coefficients, are summed by a summing amplifier. The output driver meets the requirements defined in IEEE 802.3ap Clause 72.

Figure 4 • 10GBASE-KR Output Driver

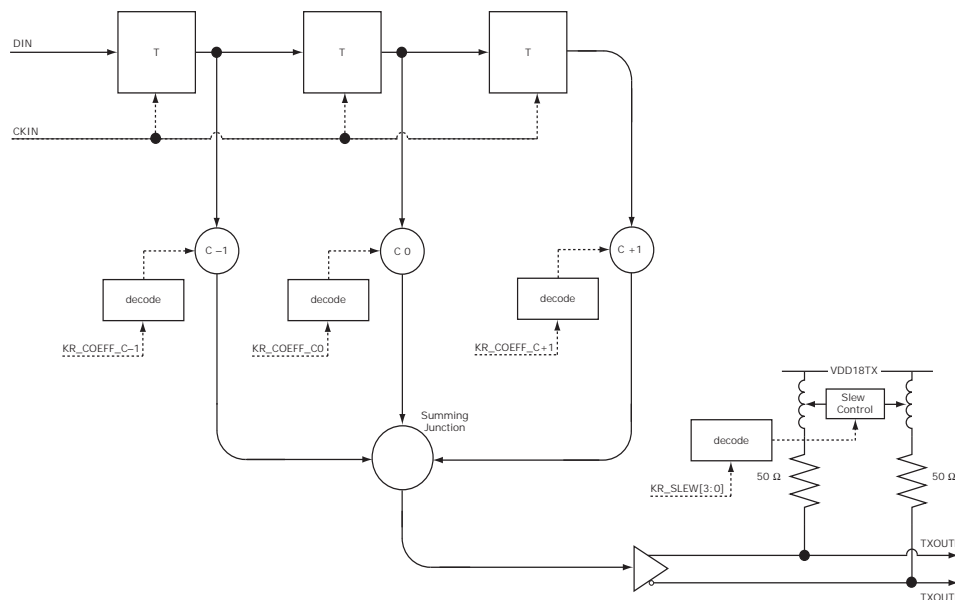

The final output stage has 50 Ω back-termination with inductor peaking. The output slew rate is controlled by adjusting the effectiveness of the inductors.

The test pattern for the transmitter output waveform is the square wave test pattern with at least eight consecutive 1s. The following illustration shows the transmitter output waveform test, based on voltages V_1 through V_6 , ΔV_2 , and ΔV_5 .

Figure 5 • KR Test Pattern

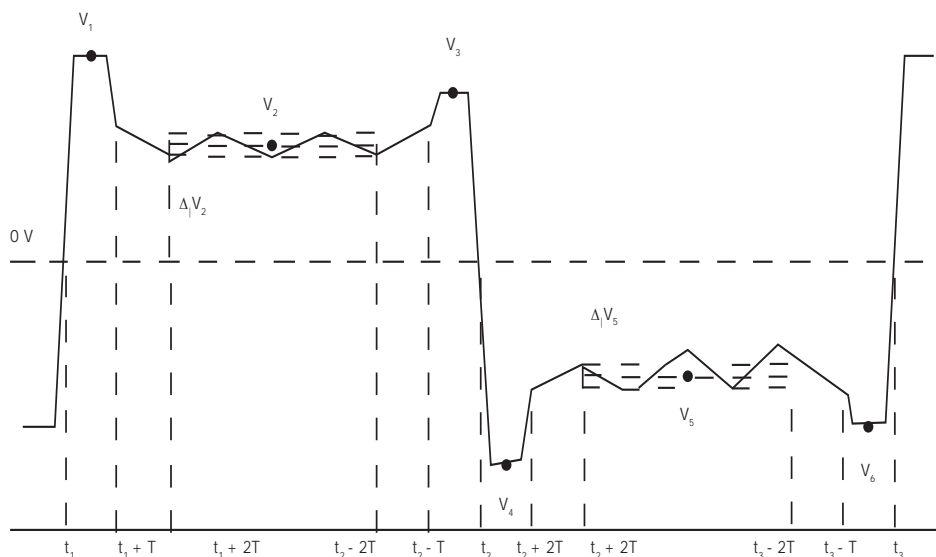

The output waveform is manipulated through the state of the coefficient C(-1), C(0), and C(+1).

3.3 WAN Interface Sublayer (WIS)

The WAN interface sublayer (WIS) is defined in IEEE 802.3ae Clause 50. The VSC8489-02 WIS block is fully compliant with this specification. The VSC8489-02 offers additional controls, ports, and registers to allow integration into a wider array of SONET/SDH equipment.

In addition to the SONET/SDH features addressed by WIS as defined by IEEE, most SONET/SDH frames/mappers contain additional circuitry for implementing operation, administration, maintenance, and provisioning (OAM&P). These frames/mappers also support special features to enable compatibility

with legacy SONET/SDH solutions. Because the VSC8489-02 WIS leverages Microsemi's industry leading framer/mapper technology, it contains suitable features for standard SONET/SDH equipment. This includes the transmit/receive overhead serial interfaces (TOSI/ROSI) commonly used for network customization and OAM&P support for SONET/SDH errors not contained in the WIS standard, support for common legacy SONET/SDH implementations, and SONET/SDH jitter and timing quality.

3.3.1 Operation

WAN mode is enabled by asserting 2x0007.0 (SPI/MDIO/TWS) or wis_ctrl2.wan_mode. Status register bit 1xA101.3 (SPI/MDIO/TWS) or Vendor_Specific_PMA_Status_2.WAN_ENABLED_status indicates whether WAN mode is enabled or not. The Rx and Tx paths both have WAN mode enabled or disabled. It is not possible to have WAN mode in the Tx path enabled while the Rx path is disabled, or vice versa.

The transmit portion of the WIS does the following:

- Maps data from the PCS through the WIS service interface and to the SONET/SDH synchronous payload envelope (SPE)
- Generates path, line, and section overhead octets
- Scrambles the frame
- Transmits the frame to the PMA service interface

The receive portion of the WIS does the following:

- Receives data from the PMA service interface
- Delineates octet and frame boundaries
- Descrambles the frame
- Processes section, line, and path overhead information that contain alarms and parity errors
- Interprets the pointer field
- Extracts the payload for transmittal to the PCS through the WIS service interface

The following illustration shows the WIS block diagram.

Figure 6 • WIS Transmit and Receive Functions

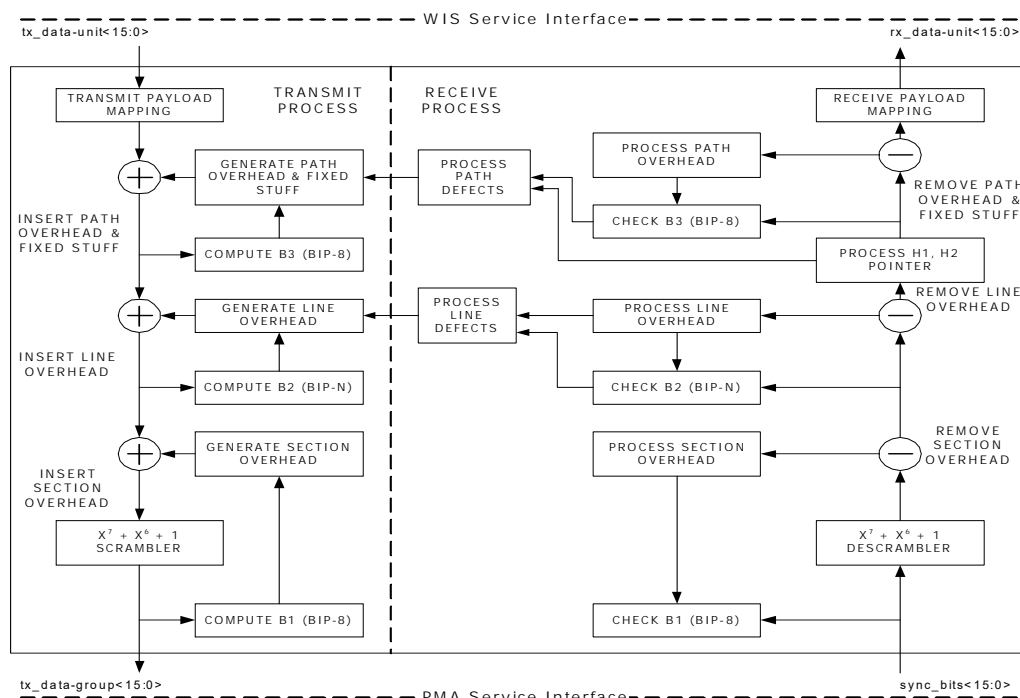

The following illustration shows the WIS frame structure.

Figure 7 • WIS Frame Structure

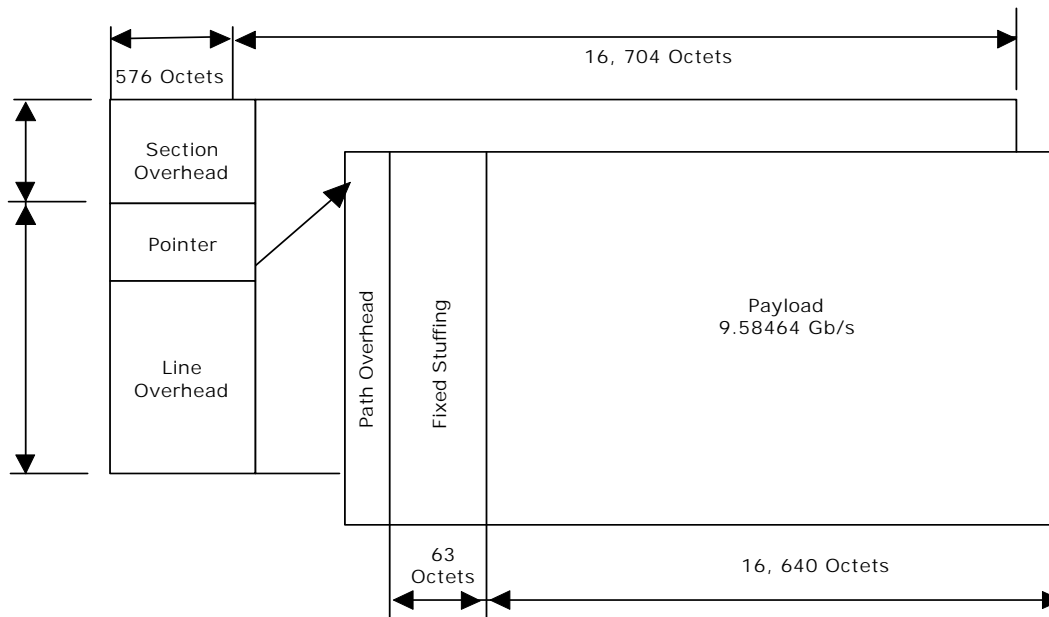

The following illustration shows the positions of the section and line overhead octets within the WIS frame.

Figure 8 • STS-192c/STM-64 Section and Line Overhead Structure

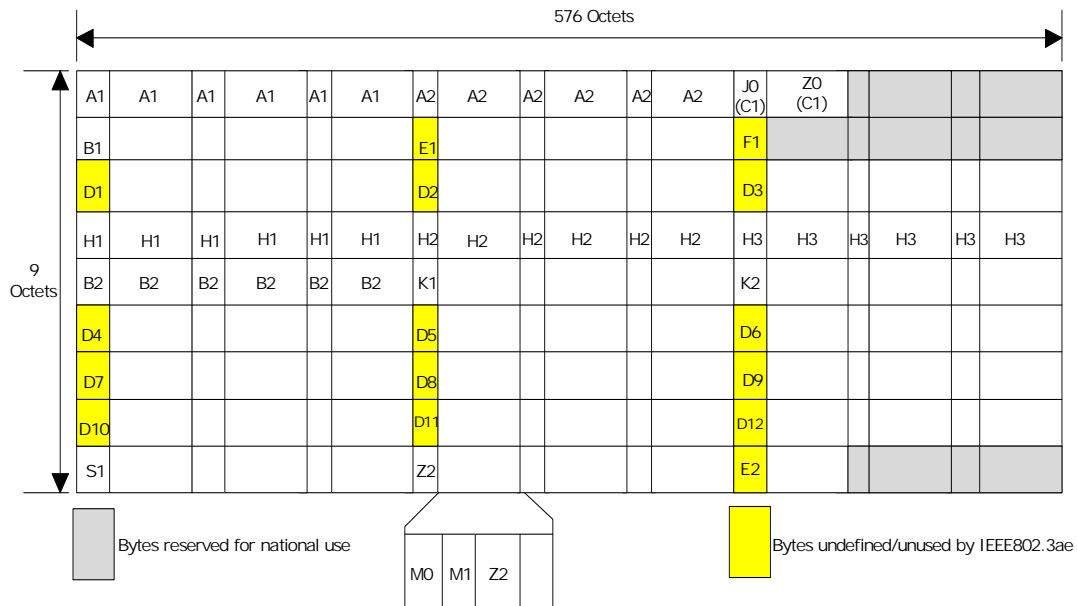

The following illustration shows the path overhead octet positions.

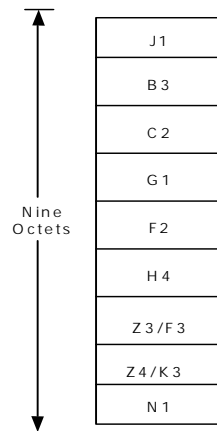
Figure 9 • Path Overhead Octets

3.3.2 Section Overhead

The section overhead portion of the SONET/SDH frame supports frame synchronization, a tandem connection monitor (TCM) known as the Section Trace, a high-level parity check, and some OAM&P octets. The following table lists each of the octets, including their function, specification, and related information.

The VSC8489-02 device provides a mechanism to transmit a static value as programmed by the MDIO interface. However, by definition, MDIO is not fast enough to alter the octet on a frame-by-frame basis.

Table 2 • Section Overhead

Overhead Octet	Function	IEEE 802.3ae WIS Usage	Recommended Value	WIS Extension
A1	Frame alignment	Supported	0xF6	Register (EWIS_TX_A1_A2) TOSI and ROSI access.
A2	Frame alignment	Supported	0x28	Register (EWIS_TX_A1_A2) TOSI and ROSI access.
J0	Section trace	Specified value	For more information, see Section Trace (J0) , page 16	A 1-byte, 16-byte, or 64-byte trace message can be sent using registers WIS_Tx_J0_Octets_1_0 to WIS_Tx_J0_Octets_15_14, EWIS_TX_MSGLEN, or EWIS_Tx_J0_Octets_17_16 to EWIS_Tx_J0_Octets_63_62 and received using registers WIS_Rx_J0_Octets_1_0 to WIS_Rx_J0_Octets_15_14, EWIS_RX_MSGLEN, and EWIS_Rx_J0_Octets_17_16 to EWIS_Rx_J0_Octets_63_62. TOSI and ROSI access.
Z0	Reserved for section growth	Unsupported	0xCC	Register EWIS_TX_Z0_E1 TOSI and ROSI access.

Table 2 • Section Overhead (continued)

Overhead Octet	Function	IEEE 802.3ae WIS Usage	Recommended Value	WIS Extension
B1	Section error monitoring (Section BIP-8)	Supported	Bit interleaved parity - 8 bits, as specified in T1.416	Using the TOSI, the B1 byte can be masked for test purposes. For each B1 mask bit that is cleared to 0 on the TOSI interface, the transmitted bit is left unchanged. For each B1 mask bit that is set to 1 on the TOSI interface, the transmitted bit is inverted. Using the ROSI, the B1 error locations can be extracted. Periodically latched counter (EWIS_B1_ERR_CNT1-EWIS_B1_ERR_CNT0) is available.
E1	Orderwire	Unsupported	0x00	Register EWIS_TX_Z0_E1 TOSI and ROSI access.
F1	Section user channel	Unsupported	0x00	Register EWIS_TX_F1_D1 TOSI and ROSI access.
D1-D3	Section data communications channel (DCC)	Unsupported	0x00	Register EWIS_TX_F1_D1 to EWIS_TX_D2_D3 TOSI and ROSI access.

3.3.2.1 Frame Alignment (A1, A2)

The SONET/SDH protocol is based upon a frame structure that is delineated by the framing octets, A1 and A2. The framing octets are defined to be 0xF6 and 0x28 respectively. In the transmit direction, all 192 A1 octets are sourced from the TX_A1 (EWIS_TX_A1_A2.TX_A1) register while the A2 octets are sourced from the TX_A2 (EWIS_TX_A1_A2.TX_A2) register.

In the receive direction, the frame aligner monitors the input bus from the PMA and performs word alignment. The frame alignment architecture is composed of a primary and secondary state machine. The selected frame alignment and synchronization pattern have implications on the tolerated input BER. The higher the input BER, the less likely the frame boundary can be found. The chances of finding the frame boundary are improved by reducing the number of A1/A2 bytes required to be detected (using a smaller pattern width). According to the WIS specification, the minimum for all parameters allows a signal with an error tolerance of 10^{-12} to be framed.

The following illustration shows the primary synchronization state diagram.

Figure 10 • Primary Synchronization State Diagram

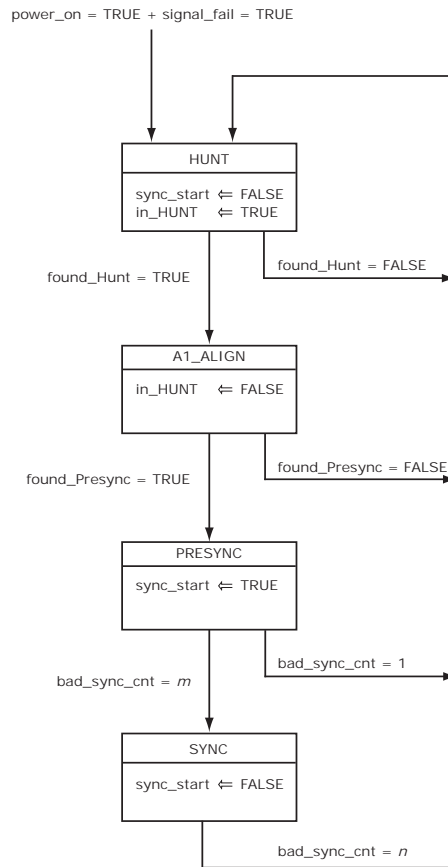

The following table lists the variables for the primary state diagram. The variables are reflected in registers EWIS_RX_FRM_CTRL1 and EWIS_RX_FRM_CTRL2 that can be alternately reconfigured.

Table 3 • Framing Parameter Description and Values

Name	Description	IEEE 802.3ae Parameter	IEEE 802.3ae Range	Range	Default
Sync_Pattern width	Sequence of f consecutive A1s followed immediately by a sequence of f consecutive A2s. If f = 2, Sync_Pattern is A1A1A2A2.	f	2 to 192	0 to 16 Exceptions: If f = 0, Sync_Pattern is A1 + 4 MSBs of A2. If f = 1, Sync_Pattern is A1A1A2.	2
Hunt_Pattern width	Sequence of i consecutive A1s.	i	1 to 192	1 to 16.	4
Presync_Pattern A1 width	Presync_Pattern consists of a sequence of j consecutive A1s followed immediately by a sequence of k consecutive A2s.	j	16 to 190	1 to 16 If set to 0, behaves as if set to 1. If set to 17 to 31, behaves as if set to 16.	16

Table 3 • Framing Parameter Description and Values (continued)

Name	Description	IEEE 802.3ae Parameter	IEEE 802.3ae Range	Range	Default
Presync_Pattern A2 width	Presync_Pattern consists of a sequence of j consecutive A1s followed immediately by a sequence of k consecutive A2s.	k	16 to 192	0 to 16 0 means only 4 MSB of A2 are used. If set to 17 to 31, behaves as if set to 16.	16
SYNC state entry	Number of consecutive frame boundaries needed to be found after entering the PRESYNC state in order to enter the SYNC state.	m	4 to 8	1 to 15 If set to 0, behaves as if set to 1.	4
SYNC state exit	Number of consecutive frame boundary location errors detected before exiting the SYNC state.	n	1 to 8	1 to 15 If set to 0, behaves as if set to 1.	4

The following illustration shows the secondary synchronization state diagram.

Figure 11 • Secondary Synchronization State Diagram

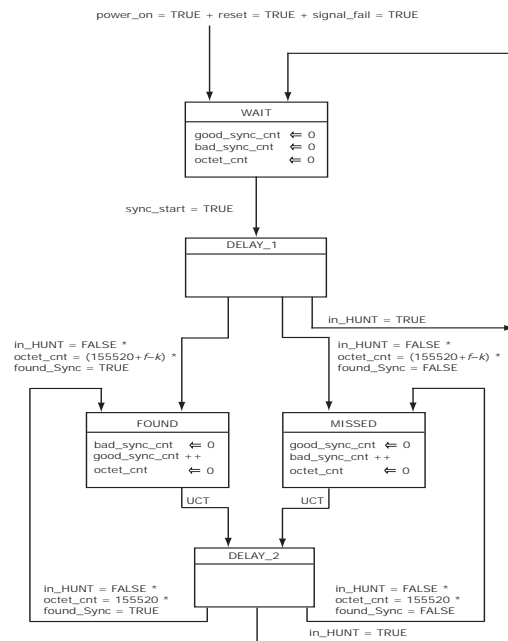

3.3.2.2 Loss of Signal (LOS)

WIS_STAT3.LOS alarm status is a latch-high register; back-to-back reads provide both the event as well as status information. The LOS event also asserts register EWIS_INTR_PEND1.LOS_PEND until read. This event can propagate an interrupt to either WIS_INTA or WIS_INTB based upon mask enable bits EWIS_INTR_MASKA_1.LOS_MASKA and EWIS_INTR_MASKB_1.LOS_MASK.

There is no hysteresis on the LOS detection, and so it is recommended to have the system software to implement a sliding window to check on the LOS before qualifying the presence of a signal. As an alternative, Rx_LOS can be used from the optical module (through LOPC) to qualify the input signal. In

addition to using analog detection, digital detection such as PCS_Rx_Fault is recommended to determine if the input signal is good.

When the near-end device experiences LOS, it is possible to automatically transmit a remote defect indication (RDI-L) to the far-end for notification purposes. The EWIS_RXTX_CTRL.TXRDIL_ON_LOS, if asserted, overwrites the outgoing K2 bits with the RDI-L code. In the receive path, it is possible to trigger an AIS-L state (alarm assertion plus forcing the payload to an all ones state) upon a detection of an LOS condition. This is accomplished by asserting EWIS_RXTX_CTRL.RXAISL_ON_LOS.

3.3.2.3 Loss of Optical Carrier (LOPC)

The input pin LOPC can be used by external optic components to directly assert the loss of optical power to the physical media device. Any change in level on the LOPC input asserts register EWIS_INTR_PEND2.LOPC_PEND until read. The current status of the LOPC input pin can be read in register EWIS_INTR_STAT2.LOPC_STAT. The LOPC input can be active high or active low by setting the Vendor_Specific_LOPC_Control.LOPC_state_inversion_select bit appropriately. The LOPC_PEND bit can propagate an interrupt to either WIS_INTA or WIS_INTB based upon mask enable bits EWIS_INTR_MASKA_2.LOPC_MASKA and EWIS_INTR_MASKB_2.LOPC_MASKB.

When the near-end device experiences LOPC, it is possible to automatically transmit a remote defect indication (RDI-L) to the far-end to notify it of a problem. The EWIS_RXTX_CTRL.TXRDIL_ON_LOPC register bit, if asserted, overwrites the outgoing K2 bits with the RDI-L code. In the receive path, it is possible to force the receive framer into an LOF state, thereby squelching subsequent alarms and invalid payload data processing. This is accomplished by asserting EWIS_RX_ERR_FRC1.RXLOF_ON_LOPC. Similar to the LOF condition forced upon an LOPC, the EWIS_RXTX_CTRL.RXAISL_ON_LOPC can force the AIS-L alarm assertion, plus force the payload to an all ones state to indicate to the PCS the lack of valid data upon an LOPC condition.

3.3.2.4 Severely Errored Frame (SEF)

Upon reset, the VSC8489-02 device Rx WIS enters the out-of-frame (OOF) state with both the severely errored frame (SEF) and loss of frame (LOF) alarms active. The SEF state is terminated when the framer enters the SYNC state. The framer enters the SYNC state after EWIS_RX_FRM_CTRL2.SYNC_ENTRY_CNT plus 1 consecutive frame boundaries are identified. An SEF state is declared when the framer enters the out-of-frame (OOF) state. The frame changes from the SYNC state to the OOF state when EWIS_RX_FRM_CTRL2.SYNC_EXIT_CNT consecutive frames with errored frame alignment words are detected. The SEF alarm condition is reported in WIS_STAT3.SEF. This register latches high providing a combination of interrupt pending and status information within consecutive reads.

An additional bi-stable interrupt pending bit SEF_PEND (EWIS_INTR_PEND1.SEF_PEND) is provided to propagate an interrupt to either WIS_INTA or WIS_INTB based upon mask enable bits SEF_MASKA (EWIS_INTR_MASKA_1.SEF_MASKA) and SEF_MASKB (EWIS_INTR_MASKB_1.SEF_MASKB).

3.3.2.5 Loss of Frame (LOF)

An LOF occurs when an out-of-frame state persists for an integrating period of EWIS_LOF_CTRL1.LOF_T1 frames. To provide for the case of intermittent OOFs when not in the LOF state, the integrating timer is not reset to zero until an in-frame condition persists continuously for EWIS_LOF_CTRL1.LOF_T2 frames. The LOF state is exited when the in-frame state persists continuously for EWIS_LOF_CTRL2.LOF_T3 frames. The LOF state is indicated by the WIS_STAT3.LOF register being asserted. This register latches high, providing a combination of pending and status information over consecutive reads.

An additional bi-stable interrupt pending bit, EWIS_INTR_PEND1.LOF_PEND, is provided to propagate an interrupt to either WIS_INTA or WIS_INTB based upon mask enable bits EWIS_INTR_MASKA_1.LOF_MASKA and EWIS_INTR_MASKB_1.LOF_MASKB.

When the near-end device experiences an LOF condition, it is possible to automatically transmit a remote defect indication (RDI-L) to the far end to notify it of a problem. The EWIS_RXTX_CTRL.TXRDIL_ON_LOF, if asserted, overwrites the outgoing K2 bits with the RDI-L code.

In the receive path, it is possible to force a AIS-L state (alarm assertion plus forcing the payload to an all ones state) upon a detection of an LOF condition. This is accomplished by asserting EWIS_RXTX_CTRL.RXAISL_ON_LOF.

3.3.2.6 Section Trace (J0)

The J0 octet often carries a repeating message called the Section Trace message. The default transmitted message length is 16 octets whose contents are defined in WIS_TXJ0 (WIS_Tx_J0_Octets_1_0-WIS_Tx_J0_Octets_15_14). If no active message is being broadcast, a default section trace message is transmitted. This section trace message consists of 15 octets of zeros and a header octet formatted according to Section 5 of ANSI T1.269-2000. The header octet for the 15-octets of zero is 0x89. The default values of WIS_TXJ0 (WIS_Tx_J0_Octets_1_0-WIS_Tx_J0_Octets_15_14) do not contain the 0x89 value of the header octet, so software must write this value.

The J0 octet in the receive direction is assumed to be carrying a 16-octet continuously-repeating section trace message. The message is extracted from the incoming WIS frames and stored in WIS_RXJ0 (WIS_Rx_J0_Octets_1_0-WIS_Rx_J0_Octets_15_14). The WIS receive process does not delineate the message boundaries, thus the message might appear rotated between new frame alignment events.

The VSC8489-02 device supports two alternate message types, a single repeating octet and a 64-octet message. The message type can be independently selected for the transmit and receive direction. The transmit direction is configured using EWIS_TX_MSGLEN.J0_TXLEN, while EWIS_RX_MSGLEN.J0_RX_LEN configures the receive path.

When the transmit direction is configured for a 64-octet message, the first 16 octets are programmed in WIS_TXJ0 (WIS_Tx_J0_Octets_1_0-WIS_Tx_J0_Octets_15_14), while the 48 remaining octets are programmed in EWIS_TXJ0 (EWIS_Tx_J0_Octets_17_16-EWIS_Tx_J0_Octets_63_62). Likewise, the first 16 octets of the receive message are stored in WIS_RXJ0 (WIS_Rx_J0_Octets_1_0-WIS_Rx_J0_Octets_15_14), while the other 48 octets are stored in EWIS_RXJ0 (EWIS_Rx_J0_Octets_17_16-EWIS_Rx_J0_Octets_63_62). The receive message is updated every 125 μ s with the recently received octet. Any persistency or message matching is expected to take place within the station manager.

3.3.2.7 Reserved for Section Growth (Z0)

The WIS standard does not support the Z0 octet and requires transmission of 0xCC in the octet locations. A different Z0 value can be transmitted by configuring EWIS_TX_Z0_E1.TX_Z0. The TX_Z0 default is 0xCC.

3.3.2.8 Scrambling/Descrambling

The transmit signal (except for row 1 of the section overhead) is scrambled according to the standards when register bit EWIS_TXCTRL2.SCR is asserted, which is the default state. When deasserted, the scrambler is disabled.

The receive signal descrambler is enabled by default. The descrambler can be bypassed by deasserting register bit EWIS_RX_CTRL1.DSCR_ENA.

Enabling loopback H4 and turning off the WIS scrambler and descrambler may yield an interesting data point when debugging board setups. The CRU in the ingress PMA path would not have enough edge transitions in the data to reliably recover the clock if the chip were receiving non-scrambled data. The same would be true for any far-end device connected to the egress PMA if the scrambler were turned off. The WIS scrambler and descrambler should be left on under normal operating conditions.

3.3.2.9 Section Error Monitoring (B1)

The B1 octet is a bit interleaved parity-8 (BIP-8) code using even parity calculated over the previous STS-192c frame, post scrambling. The computed BIP-8 is placed in the following outgoing SONET frame before scrambling.

In the receive direction, the incoming frame is processed, and a BIP-8 is calculated. The calculated value is then compared with the B1 value received in the following frame. The difference between the calculated and received octets are accumulated into the WIS_B1_CNT register. This counter rolls over after the maximum count. This counter is cleared upon device reset.

The EWIS_B1_ERR_CNT1 and EWIS_B1_ERR_CNT0 registers provide a count of the number of received B1 parity errors. This register is updated with the internal count value upon a PMTICK condition, after which the internal counter is reset to zero. When the counter is nonzero, the EWIS_INTR_PEND2.B1_NZ_PEND event register is asserted until read. A non-latch high version of this event, EWIS_INTR_STAT2.B1_NZ_STAT, is also available. This event can propagate an interrupt to either WIS_INTA or WIS_INTB based upon mask enable bits EWIS_INTR_MASKA_2.B1_NZ_MASKA and EWIS_INTR_MASKB_2.B1_NZ_MASKB.

The B1_ERR_CNT can optionally be configured to increment on a block count basis, a maximum increment of 1 per errored frame regardless of the number of errors received. This mode is enabled by asserting EWIS_CNT_CFG.B1_BLK_MODE.

3.3.2.10 Section Orderwire (E1)

The WIS standard does not support the E1 octet and requires transmission of 0x00 in the octet location. A different E1 value can be transmitted by configuring EWIS_TX_Z0_E1.TX_E1 (whose default is 0x00).

3.3.2.11 Section User Channel (F1)

The WIS standard does not support the F1 octet and requires transmission of 0x00 in the octet location. A different F1 value can be transmitted by configuring EWIS_TX_F1_D1.TX_F1 (whose default is 0x00).

3.3.2.12 Section Data Communication Channel (DCC-S)

The WIS standard does not support the DCC-S octets and requires transmission of 0x00 in the octet locations. Different DCC-S values can be transmitted by configuring EWIS_TX_F1_D1.TX_D1, EWIS_TX_D2_D3.TX_D2, and EWIS_TX_D2_D3.TX_D3 (all of which default to 0x00).

3.3.2.13 Reserved, National, and Unused Octets

The VSC8489-02 device transmits 0x00 for all reserved, national, and unused overhead octets.

3.3.3 Line Overhead

The line overhead portion of the SONET/SDH frame supports pointer interpretation, a per channel parity check, protection switching information, synchronization status messaging, far-end error reporting, and some OAM&P octets.

The VSC8489-02 device provides a mechanism to transmit a static value as programmed by the MDIO interface. However, by definition, MDIO is not fast enough to alter the octet on a frame-by-frame basis. The following table lists each of the octets including their function, specification, and related information.

Table 4 • Line Overhead Octets

Overhead Octet	Function	IEEE 802.3ae WIS Usage	Recommended Value	WIS Extension
H1-H2	Pointer	Specified value	SONET mode: STS-1: 0x62, 0x0A STS-n: 0x93, 0xFF SDH mode: STS-1: 0x6A, 0x0A STS-n: 0x9B, 0xFF	Registers EWIS_TX_C2_H1.TX_H1 and EWIS_TX_H2_H3.TX_H2 TOSI and ROSI access.
H3	Pointer action	Specified value	0x00	Register EWIS_TX_H2_H3.TX_H3 TOSI and ROSI access.

Table 4 • Line Overhead Octets (continued)

Overhead Octet	Function	IEEE 802.3ae WIS Usage	Recommended Value	WIS Extension
B2	Line error monitoring (line BIP-1536)	Supported	BIP-8, as specified in T1.416	Using the TOSI, the B2 bytes can be masked for test purposes. For each B2 mask bit that is cleared to 0 on the TOSI interface, the transmitted bit is left unchanged. For each B2 mask bit that is set to 1 on the TOSI interface, the transmitted bit is inverted. Using the ROSI, the B2 error locations can be extracted. Periodically latched counter (EWIS_B1_ERR_CNT1-EWIS_B1_ERR_CNT0) is available.
K1, K2	Automatic protection switch (APS) channel and line remote defect identifier (RDI-L)	Specified value	For more information about K2 coding, see Table 5 , page 20	Register Registers EWIS_TX_G1_K1.TX_K1 and EWIS_TX_K2_F2.TX_K2 TOSI and ROSI access.
D4-D12	Line data communications channel (DCC)	Unsupported	0x00	Registers EWIS_TX_D4_D5 and EWIS_TX_D6_H4 TOSI and ROSI access.
S1	Synchronization messaging	Unsupported	0x0F	Register EWIS_TX_S1_Z1.TX_S1 TOSI and ROSI access.
Z1	Reserved for Line growth	Unsupported	0x00	Register EWIS_TX_S1_Z1.TX_Z1 TOSI and ROSI access.
M0/M1	STS-1/N line remote error indication (REI)	M0 unsupported, M1 supported	0x00/number of detected B2 errors in the receive path, as specified in T1.416	TOSI and ROSI access. The VSC8489-02 device supports a mode that uses only M1 to back report REI-L (EWIS_MODE_CTR.REI_MODE = 0) and another mode which uses both M0 and M1 to back report REI-L (EWIS_MODE_CTR.REI_MODE = 1). For more information, see Line Error Monitoring (B2) , page 19.
E2	Orderwire	Unsupported	0x00	Register EWIS_TX_Z2_E2.TX_E2 TOSI and ROSI access.
Z2	Reserved for Line growth	Unsupported	0x00	Register EWIS_TX_Z2_E2.TX_Z2 TOSI and ROSI access.

3.3.3.1 Line Error Monitoring (B2)

The B2 octet is a BIP-8 value calculated over each of the previous STS-1 channels excluding the section overhead and pre-scrambling. As the B2 octet is calculated on an STS-1 basis, there are 192 B2 octets within an STS-192/STM-64 frame. Each of the 192 calculated BIP-8 octets are then placed in the outgoing SONET/SDH frame.

Note: For SONET mode, when the number of errors detected in the B2 octet of a receive frame is greater than 255, the total count of detected errors is transmitted in more than one frame. Even when no B2 errors are detected in subsequent frames, the number of detected B2 errors going into an accumulator will be limited to 255 if more than 255 errors are detected in a frame. The Tx framer pulls the REI-L count out of the accumulator when REI-L is transmitted to be compliant with T1-105.

In the receive direction, the incoming frame is processed, a per STS-1 BIP-8 is calculated (excluding section overhead and after descrambling), and then compared to the B2 value in the following frame. Errors are accumulated in the WIS_B2_CNT1 and WIS_B2_CNT0 registers. This counter is non-saturating and so rolls over after its maximum count. The counter is cleared only on device reset.

An additional 32-bit B2 error counter is provided in B2_ERR_CNT (EWIS_B2_ERR_CNT1 and EWIS_B2_ERR_CNT0), which is a saturating counter and is latched and cleared based upon a PMTICK event. Errors are accumulated from the previous PMTICK event. When the counter is nonzero, the EWIS_INTR_PEND2.B2_NZ_PEND event register is asserted until read. A non-latch high version of this event is available in EWIS_INTR_STAT2.B2_NZ_STAT. This event can propagate an interrupt to either WIS_INTA or WIS_INTB, based on mask enable bits EWIS_INTR_MASKA_2.B2_NZ_MASKA and EWIS_INTR_MASKB_2.B2_NZ_MASKB.

The B2_ERR_CNT can optionally be configured to increment on a block count basis, a maximum increment of 1 per errored frame regardless of the number of errors received. This mode is enabled by asserting EWIS_CNT_CFG.B2_BLK_MODE.

It is possible that two sets of B2 bytes (from two SONET/SDH frames) are received by the Rx WIS logic in a period of time when only one M0/M1 octet is transmitted. In this situation, one of the two B2 error counts delivered to the Tx WIS logic is discarded. This situation occurs when the receive data rate is faster than the transmit data rate. Similarly, when the transmit data rate is faster than the receive data rate, a B2 error count is not available for REI-L insertion into the M0/M1 octets of the transmitted SONET/SDH frame. A value of zero is transmitted in this case. This behavior is achieved by using a FIFO to transfer the detected B2 error count from the receive to transmit domains.

A FIFO overflow or underflow condition is not considered an error. Instead, it is recovered from gracefully, as described above. A FIFO overflow or underflow eventually occurs unless the transmit and receive interfaces are running at the same average data rate. Because the received and transmitted frames can differ by, at most, 40 ppm (± 20 ppm) and still meet the industry standards, this "slip" can happen no more often than once every 3.1 seconds.

3.3.3.2 APS Channel and Line Remote Defect Identifier (K1, K2)

The K1 and K2 octets carry information regarding automatic protection switching (APS) and line remote defect identifier (RDI-L). The K1 octet and the most significant five bits of the K2 octet contain the APS channel information. The transmitted values can be configured at EWIS_TX_G1_K1.TX_K1 and EWIS_TX_K2_F2.TX_K2. The default values of all zeros are compliant with the WIS standard.

The three least significant bits within the K2 octet carry the RDI-L encoding, as defined by section 7.4.1 of ANSI T1.416-1999 and as shown in the following table.

Table 5 • K2 Encodings

Indicator	K2 Value for Bits 6, 7, 8	Interpretation
RDI-L	110	<p>Remote error indication.</p> <p>For the receive process, an RDI-L defect occurs after a programmable number of RDI-L signals are received in contiguous frames and is terminated when no RDI-L is received for the same number of contiguous frames.</p> <p>An RDI-L can be forced by asserting EWIS_RX_ERR_FRC1.FRC_RX_RDIL.</p> <p>For the transmit process, the WIS standard does not indicate when or how to transmit RDI-L. VSC8489-02 provides the option of transmitting K2 by programming it through the TOSI, by programming it using the K2_TX MDIO register, or by programming it based on the contents of the K2_TX register with bits 6, 7, and 8 modified depending on the status of the following: LOPC, LOS, LOF, AIS-L and their associated transmit enable bits enable bits TXRDIL_ON_LOPC, TXRDIL_ON_LOS, TXRDIL_ON_LOF and TXRDIL_ON_AISL in register EWIS_RXTX_CTRL.</p>
AIS-L	111	<p>Alarm indication signal (line).</p> <p>For the receive process, this is detected based on the settings of the K2 byte. When AIS-L is detected, the WIS link status is down and WIS_STAT3.AISL is set high. This also contributes to errored second (ES) and severally errored second (SES) reports. For standard WIS operation, this is never transmitted.</p>
Idle (normal)	000	Unless RDI-L exists, the standard WIS transmits idle.

Although the transmission of RDI-L is not explicitly defined within the WIS standard, the VSC8489-02 device allows the automatic transmission of RDI-L upon the detection of LOPC, LOS, LOF, or AIS-L conditions. These features are enabled by asserting TXRDIL_ON_LOPC, TXRDIL_ON_LOS, TXRDIL_ON_LOF and TXRDIL_ON_AISL in register EWIS_RXTX_CTRL.

Note: The RDI-L code of 110 is transmitted by the DUT only when Rx AIS-L is asserted. For example, if AIS-L is detected by the DUT for five continuous frames in the Rx direction, then the RDI-L code is transmitted for five frames in the Tx direction (not 20 frames as stated in the ANSI T1.105 specification).

The VSC8489-02 device can force a RDI-L condition independent of the K2 transmit value by asserting EWIS_TXCTRL2.FRC_TX_RDI. Likewise, a AIS-L condition can be forced by asserting EWIS_TXCTRL2.FRC_TX_AISL. If both conditions are forced, the AIS-L value is transmitted.

In the receive direction, the RDI-L alarm (K2[6:8] = 110, using SONET nomenclature) and the AIS-L alarm (K2[6:8] = 111, using SONET nomenclature) are not asserted until the condition persists for a programmable number of contiguous frames. This value is programmable at EWIS_RX_ERR_FRC1.APS_THRES and is typically set to values of 5 or 10. The AIS-L is detected by the receiver after the programmable number of frames is received, and results in the reporting of AIS-P.

The WIS standard defines WIS_STAT3.RDIL and WIS_STAT3.AISL as a read-only latch-high register, so a read of a one in this register indicates that an error condition occurred since the last read. A second read of the register provides the current status of the event as to whether the alarm is currently asserted. EWIS_INTR_PEND1.RDIL_PEND and EWIS_INTR_PEND1.AISL_PEND assert whenever the RDI-L or AIS-L state changes (assert or deassert). These interrupts have associated mask enable bits (EWIS_INTR_MASKA_1.RDIL_MASKA, EWIS_INTR_MASKB_1.RDIL_MASKB, EWIS_INTR_MASKA_1.AISL_MASKA and EWIS_INTR_MASKB_1.AISL_MASKB), which, if enabled, propagate an interrupt to the WIS_INTA/B pins.

For test purposes, the VSC8489-02 device can induce a RDI-L condition in the receive direction independent of the received K2 value by asserting EWIS_RX_ERR_FRC1.FRC_RX_RDIL. Likewise, a AIS-L condition can be forced in the receive direction by asserting EWIS_RX_ERR_FRC1.FRC_RX_AISL.

3.3.3.3 Line Data Communications Channel (D4 to D12)

The WIS standard does not support Line Data Communications Channel (L-DCC) octets (D4-D12) and recommends transmitting 0x00 within these octets. The D4-D12 transmitted values can be programmed in registers EWIS_TX_D4_D5 - EWIS_TX_D12_Z4. The register defaults are all 0x00. The receive L-DCC octets are only accessible through the ROSI port.

3.3.3.4 STS-1/N Line Remote Error Indication (M0 and M1)

The M0 and M1 octets are used for back reporting the number of B2 errors received, known as remote error indication (REI-L). The value in this octet comes from the B2 error FIFO, as discussed with the B2 octet. The WIS standard does not support the M0 octet and recommends transmitting 0x00 in place of the M0 octet. However, the WIS standard supports the M1 octet in accordance with T1.416.

Two methods for back-reporting exist and are controlled by EWIS_TXCTRL2.SDH_TX_MODE. Because a single frame can contain up to 1536 B2 errors while the M1 byte alone can only back report a maximum of 255 errors, a discrepancy exists. When G707_2000_REIL is deasserted, only the M1 byte is used and a maximum of 255 errors are back-reported. When G707_2000_REIL is asserted, two octets per frame are used for back reporting- the M1 octet and the M0 octet (not the first STS-1 octet, but the second STS-1 octet). In this mode, a total of 1536 errors can be back-reported per frame.

In the receive direction, the VSC8489-02 device detects and accumulates errors according to the EWIS_MODE_CTRL.REI_MODE setting. The VSC8489-02 device deviates from the G.707 standard by not interpreting REI-L values greater than 1536 as zero. The WIS standard defines a 32-bit REI-L counter in registers WIS_REIL_CNT1 and WIS_REIL_CNT0. This counter is non-saturating and so rolls over after its maximum count. The counter is cleared only on device reset.

An additional 32-bit REI-L counter is provided in registers EWIS_REIL_CNT1 and EWIS_REIL_CNT0, which is a saturating counter and is latched and cleared based upon a PMTICK event. Errors are accumulated since the previous PMTICK event. When the counter is nonzero, the EWIS_INTR_PEND2.REIL_NZ_PEND event register is asserted until read. A non-latch high version of this event (EWIS_INTR_STAT2.REIL_NZ_STAT) is also available. This event can propagate an interrupt to either WIS_INTA or WIS_INTB based upon mask enable bits EWIS_INTR_MASKA_2.REIL_NZ_MASKA and EWIS_INTR_MASKB_2.REIL_NZ_MASKB.

The REIL_ERR_CNT can optionally be configured to increment on a block count basis, a maximum increment of 1 per errored frame regardless of the number of errors received. This mode is enabled by asserting EWIS_CNT_CFG.REIL_BLK_MODE.

3.3.3.5 Synchronization Messaging (S1)

The S1 octet carries the synchronization status message and provides synchronization quality measures of the transmission link in the least significant 4 bits. The WIS standard does not support the S1 octet and requires the transmission of a 0x0F within the S1 octet. A value other than 0x0F can be programmed in TX_S1 (2xE61F).

3.3.3.6 Reserved for Line Growth (Z1 and Z2)

The WIS standard does not support the Z1 or Z2 octets and requires the transmission of 0x00 in their locations. Different Z1 and Z2 values can be transmitted by programming the values at EWIS_TX_S1_Z1.TX_Z1 and EWIS_TX_Z2_E2.TX_Z2 respectively.

3.3.3.7 Orderwire (E2)

The WIS standard does not support the E2 octet and recommends transmitting 0x00 in place of the E2 octet. A value other than 0x00 can be transmitted by programming the intended value at EWIS_TX_Z2_E2.TX_E2.

3.3.4 SPE Pointer

The H1 and H2 octets are used as a pointer within the SONET/SDH frame to locate the beginning of the path overhead and the beginning of the synchronous payload envelope (SPE). Within SONET/SDH the SPE can begin anywhere within the payload area. However, IEEE 802.3ae specifies that a transmitted SPE must always be positioned solely within a single SONET/SDH frame. The constant pointer value of 522 decimal (0x20A) must be contained in the first channel's H1 and H2 octets. Together these conditions result in the H1 and H2 octets being 0x62 and 0x0A, respectively. These are the default values of EWIS_TX_C2_H1.TX_H1 and EWIS_TX_H2_H3.TX_H2. Programming these registers with alternate values does not alter the positioning of the SPE, but it might induce a loss of pointer (LOP-P) at the far-end, or at least prevent the far-end from extracting the proper payload. Furthermore, the WIS standard specifies the frame structure be a concatenated payload. For this reason, the H1 and H2 octets in channels 2 through 192 contain the concatenation indicator.

The VSC8489-02 device supports forcing the loss of pointer (LOP-P) and path alarm indication signal (AIS-P) state.

The WIS standard specifies that a 0x00 be transmitted in the H3 octet. An alternate value can be transmitted by programming EWIS_TX_H2_H3.TX_H3.

The WIS specification does not limit the pointer position within the receive SONET/SDH frame to allow interoperability to other SONET/SDH equipment. In addition to supporting the required SONET pointer rules, the VSC8489-02 device pointer interpreter optionally supports SDH pointers. This is selectable using the EWIS_MODE_CTRL.RX_SS_MODE bit. The following table shows the differences between SONET and SDH modes.

Table 6 • SONET/SDH Pointer Mode Differences

SONET	SDH
SS bits are ignored by the device pointer interpreter and not used	SS bits are set to 10 and are checked by the device pointer interpreter to determine the pointer type
All 192 bytes of H1 and H2 are checked by the pointer interpreter to determine the pointer type	The first 64 bytes are checked by the pointer interpreter to determine the pointer type (first Au-4 of an AU-4-64c)
Uses '8 out of 10' GR-253-core objective increment/decrement rule	Uses majority detect increment/decrement rule

The H1 and H2 octets combine to form a word with several fields, as shown in [Figure 12](#), page 23.

3.3.4.1 Bit Designations within Payload Pointer

The N bits [15:12] carry a new data flag (NDF). This mechanism allows an arbitrary change in the location of the payload. NDF is indicated by at least three out of the four N bits matching the code '1001' (NDF enabled). Normal operation is indicated by three out of the four N bits matching the code '0110' (normal NDF).

The last ten bits of the pointer word (D bits and I bits) carry the pointer value. The pointer value has a range from 0 to 782 that indicates the offset between the first byte after the H3 byte and the first byte of the SPE.

The SS bits are located in bits 11 and 10, and are unused in SONET mode. In SDH mode, these bits are compared with pattern '10', and the pointer is considered invalid if it does not match.

Because the VSC8489-02 device only supports concatenated frames, only the first pair of bytes (H1, H2) are called the primary pointer and have a normal format. The

rest of the H1/H2 bytes contain the concatenation indication (CI). The format for the CI is NDF enabled with a pointer value of all ones.

Figure 12 • 16-bit Designations within Payload Pointer

H1								H2							
15	14	13	12	11	10	9	8	7	6	5	4	3	2	1	0
N	N	N	N	S	S	I	D	I	D	I	D	I	D	I	D

3.3.4.2 Pointer Types

The VSC8489-02 device supports five different pointer types, as described in the following table. A normal pointer indicates the current pointer, a new data flag indicates a new pointer location, and an AIS pointer indicates AIS. The pointer increment and pointer decrement mechanism adjusts the frequency offset between the frame overhead and SPE. A pointer increment is indicated by a normal NDF that has the currently accepted pointer with the I bits inverted. A pointer decrement is indicated by a normal NDF that has the currently accepted pointer with D bits inverted.

Table 7 • H1/H2 Pointer Types

Pointer Type	nnnn Value	Pointer Value	SS bits
Normal	Three out of the four bits matching 0110	0 to 782	Matching in SDH mode, ignored in SONET mode
New data flag (NDF)	Three out of the four bits matching 1001	0 to 782	Matching in SDH mode, ignored in SONET mode
AIS pointer	1111	1111 1111 11	11
Pointer increment	Three out of the four bits matching 0110	Current pointer with I bits inverted	Matching in SDH mode, ignored in SONET mode
Pointer decrement	Three out of the four bits matching 0110	Current pointer with D bits inverted	Matching in SDH mode, ignored in SONET mode

Table 8 • Concatenation Indication Types

Pointer Type	nnnn Value	Pointer Value	SS bits
Normal concatenation indication	Three out of the four bits matching 1001	1111 1111 11	Matching in SDH mode, ignored in SONET mode
AIS concatenation indication	Pointer value, nnnn value, and SS bits are the same as the AIS pointer		
Invalid concatenation indication	Any other concatenation indication other than normal CI or AIS CI		

3.3.4.3 Pointer Adjustment Rule

The VSC8489-02 device pointer interpreter adjusts the current pointer value according to rules listed in Section 9.1.6 of ANSI T1.105-1995. In addition, no increment/decrement is accepted for at least three frames following an increment/decrement or NDF operation.

3.3.4.4 Pointer Increment/Decrement Majority Rules

In SONET mode, the pointer interpreter uses more restrictive GR-253-CORE objective rules, as follows:

- An increment is indicated by eight or more bits matching non-inverted D bits and inverted I bits.
- A decrement is indicated by eight or more bits matching non-inverted I bits and inverted D bits.

In SDH mode, the majority rules are:

- An increment is indicated by three or more inverted I bits and two or fewer inverted D bits.
- A decrement is indicated by three or more inverted D bits and two or fewer inverted I bits.
- If three or more D bits are inverted and three or more I bits are inverted, no action is taken.

3.3.4.5 Pointer Interpretation States

The pointer interpreter algorithm for state transitions can be modeled as a finite state machine with three states, as shown in the following illustration. The three states are normal (NORM), loss of pointer (LOP), and alarm indication state (AIS).

Figure 13 • Pointer Interpreter State Diagram

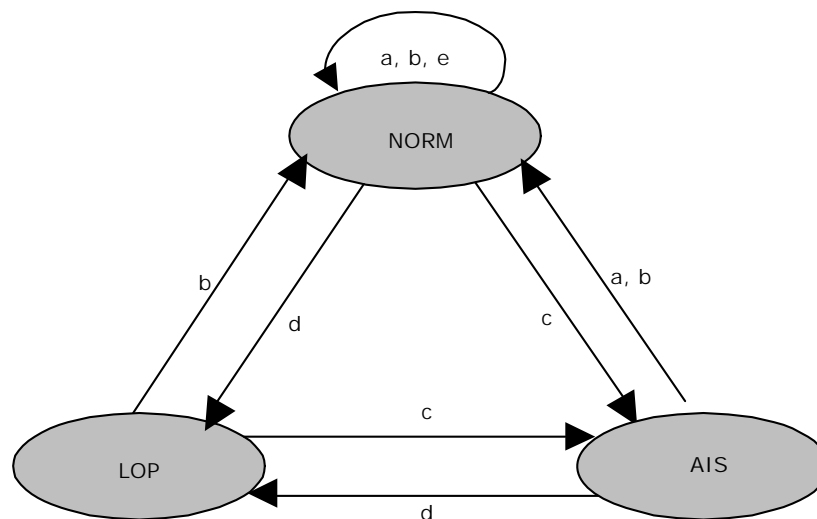

The conditions for transitions between these states are summarized in the following table

Table 9 • Pointer Interpreter State Diagram Transitions

Transitions	States	Description	Required Persistence
a	NORM → NORM AIS → NORM	<H1><H2>=<EEEESSPP><PPPPPPPP>. NDF enabled with pointer in range (0 to 782). SS bit match (if enabled).	1 frame
b	NORM → NORM LOP → NORM AIS → NORM	<H1><H2>=<DDDDSSPP><PPPPPPPP>. NDF disabled (NORM pointer) with the same pointer value in range (0 to 782). SS bit match (if enabled).	3 frames
c	NORM → AIS LOP → AIS	<H1><H2>=<11111111><11111111>. AIS pointer (0xFFFF).	3 frames
d	NORM → LOP AIS → LOP	Anything other than transitions b and c or NDF enabled (transition a) or AIS pointer when not in AIS state or NORM pointer when not in NORM state or NORM pointer with pointer value not equal to current or increment/decrement or CONC pointer or SS bit mismatch (if comparison is enabled).	8 frames
e	Justification	Valid increment or decrement indication.	1 frame

3.3.4.6 Valid Pointer Definition for Interpreter State Diagram Transitions

During an AIS state, only an AIS pointer is a valid pointer. In NORM state, several definitions of “valid pointer” for purpose of LOP detection are possible, according to GR-253-CORE. The VSC8489-02 device follows the GR-253-CORE intended definition, but adds a single normal pointer that exactly matches the current valid pointer value.

Any change in the AIS state is reflected in the alarm bit WIS_STAT3.AISP. This latch-high register reports both the event and status information in consecutive reads. The EWIS_INTR_PEND1.AISP_PEND bit remains asserted until read. This event can propagate an interrupt to either WIS_INTA or WIS_INTB,

based on mask enable bits EWIS_INTR_MASKA_1.AISP_MASKA and EWIS_INTR_MASKB_1.AISP_MASKB.

Similarly, any change in the LOP state is reflected in the alarm bit WIS_STAT3.LOPP. This latch-high register reports both the event and status information in consecutive reads. The EWIS_INTR_PEND1.LOPP_PEND bit remains asserted until read. This event can propagate an interrupt to either WIS_INTA or WIS_INTB, based upon the mask enable bits EWIS_INTR_MASKA_1.LOPP_MASKA and EWIS_INTR_MASKB_1.LOPP_MASKB.

3.3.5 Path Overhead

The path overhead portion of the SONET/SDH frame supports an end-to-end trace identifier, a payload parity check, a payload type indicator, a status indicator, and a user channel. The following table lists each of the octets, including their function.

Note: The VSC8489-02 device provides a mechanism to transmit a static value as programmed by the MDIO interface. However, by definition, MDIO is not fast enough to alter the octet on a frame-by-frame basis. Extended WIS TOSI and ROSI do not support path overhead.

Table 10 • STS Path Overhead Octets

Overhead Octet	Function	IEEE 802.3ae WIS Usage	Recommended Value	WIS Extension
J1	Path trace message	Specified value	For more information, see Overhead Octet (J1) , page 26	A 1-, 16-, or 64-byte trace message can be sent using registers (EWIS_TX_MSGLEN.J1_TXLEN, WIS_Tx_J1_Octets_1_0-WIS_Tx_J1_Octets_15_14 and EWIS_Tx_J1_Octets_17_16-EWIS_Tx_J1_Octets_63_62) and received using registers (EWIS_RX_MSGLEN.J1_RX_LEN, WIS_Rx_J1_Octets_1_0-WIS_Rx_J1_Octets_15_14, EWIS_Rx_J1_Octets_17_16-EWIS_Rx_J1_Octets_63_62).TOSI and ROSI access.
B3	Path error monitoring (path BIP-8)	Supported	Bit interleaved parity - 8 bits, as specified in T1.416	Both SONET and SDH mode B3 calculation is supported.
C2	Path signal label	Specified value	0x1A	Register (EWIS_TX_C2_H1.TX_C2). Supports persistency and mismatch detection (EWIS_MODE_CTRL.C2_EXP).
G1	Path status	Supported	As specified in T1.416	Ability to select between RDI-P and ERDI-P formats.
F2	Path user channel	Unsupported	0x00	Register (EWIS_TX_K2_F2.TX_F2).
H4	Multiframe indicator	Unsupported	0x00	Register (EWIS_TX_D6_H4.TX_H4).
Z3-Z4	Reserved for path growth	Unsupported	0x00	Register (EWIS_TX_D9_Z3.TX_Z3, EWIS_TX_D12_Z4.TX_Z4).
N1	Tandem connection maintenance and path data channel	Unsupported	0x00	Register (EWIS_TX_N1.TX_N1). TOSI and ROSI access.

3.3.5.1 Overhead Octet (J1)

The J1 transmitted octet contains a 16-octet repeating path trace message whose contents are defined in WIS Tx J1s (WIS_Tx_J1_Octets_1_0-WIS_Tx_J1_Octets_15_14). If no active message is being broadcast, a default path trace message is transmitted, consisting of 15 octets of zeros and a header octet formatted according to Section 5 of ANSI T1.269-2000. The header octet for the 15-octets of zero is 0x89. The default values of WIS Tx J1s do not contain the 0x89 value of the header octet, thus software must write this value.

By default, the J1 octet in the receive direction is assumed to be carrying a 16-octet continuously repeating path trace message. The message is extracted from the incoming WIS frames and presented in WIS Rx J1s (WIS_Rx_J1_Octets_1_0-WIS_Rx_J1_Octets_15_14). The WIS receive process does not delineate the message boundaries, thus the message might appear rotated between new frame alignment events.

The VSC8489-02 device supports two alternate message types, a single repeating octet and a 64-octet message. The message type can be independently selected for the transmit and receive direction. The transmit direction is configured using EWIS_TX_MSGLEN.J1_TXLEN while EWIS_RX_MSGLEN.J1_RX_LEN configures the receive path.

When the transmit direction is configured for a 64-octet message, the first 16 octets are programmed in WIS_Tx_J1_Octets_1_0-WIS_Tx_J1_Octets_15_14, while the 48 remaining octets are programmed in EWIS_Tx_J1_Octets_17_16-EWIS_Tx_J1_Octets_63_62. Likewise, the first 16-octets of the receive message are stored in J1_RXMSG (WIS_Rx_J1_Octets_1_0-WIS_Rx_J1_Octets_15_14), while the other 48 octets are stored in EWIS_Rx_J1_Octets_17_16-EWIS_Rx_J1_Octets_63_62. The receive message is updated every 125 μ s with the recently received octet. Any persistence or message matching is expected to take place within the station manager.

3.3.5.2 STS Path Error Monitoring (B3)

The B3 octet is a bit interleaved parity-8 (BIP-8) code, using even parity, calculated over the previous STS-192c SPE before scrambling. The computed BIP-8 is placed in the B3 byte of the following frame before scrambling.

In the receive direction, the incoming frame is processed and a B3 octet is calculated over the received frame. The calculated value is then compared with the B3 value received in the following frame. The difference between the calculated and received octets are accumulated in block (maximum increment of 1 per errored frame) fashion into a B3 error register, WIS_B3_CNT. This counter is non-saturating and so rolls over. The counter is cleared upon a device reset.

An additional 32-bit B3 error counter is provided at B3_ERR_CNT (EWIS_B3_ERR_CNT1 and EWIS_B3_ERR_CNT0), a saturating counter that is latched and cleared based upon a PMTICK event. Errors are accumulated starting from the previous PMTICK event. When the counter is nonzero, the EWIS_INTR_PEND2.B3_NZ_PEND event register is asserted until read. A non-latch high version of this event EWIS_INTR_STAT2.B3_NZ_STAT is also available. This event may propagate an interrupt to either WIS_INTA or WIS_INTB, based on the mask enable bits EWIS_INTR_MASKA_2.B3_NZ_MASKA and EWIS_INTR_MASKB_2.B3_NZ_MASKB.

The B3_ERR_CNT may optionally be configured to increment on a block count basis, a maximum increment of 1 per errored frame regardless of the number of errors received. The EWIS_CNT_CFG.B3_BLK_MODE control bit, if asserted, places the B3_ERR_CNT counter in block increment mode.

It is possible that two sets of B3 bytes (from two SONET/SDH frames) are received by the Rx WIS logic in a period of time when only one G1 octet is transmitted. In this situation, one of the two B3 error counts delivered to the Tx WIS logic is discarded. This situation occurs when the receive data rate is faster than the transmit data rate. Similarly, when the transmit data rate is faster than the receive data rate, a B3 error count is not available for REI-P insertion into the G1 octets of the transmitted SONET/SDH frame. A value of zero is transmitted in this case. This behavior is achieved by using a FIFO to transfer the detected B3 error count from the receive to transmit domains.

3.3.5.3 STS Path Signal Label and Path Label Mismatch (C2)

The C2 octet contains a value intended to describe the type of payload carried within the SONET/SDH frame. The WIS standard calls for a 0x1A to be transmitted. This is the default value of EWIS_TX_C2_H1.TX_C2.

As specified in T1.416, a path label mismatch (PLM-P), register WIS_STAT3.PLMP, event occurs when the C2 octet in five consecutive frames contain a value other than the expected one. The expected value is set in EWIS_MODE_CTRL.C2_EXP, whose default value 0x1A is compliant with the WIS standard.

When a value of 0x00 is accepted (received for five or more consecutive frames) the unequipped path pending (EWIS_INTR_PEND2.UNEQP_PEND) event is asserted until read. A non-latch high version of this event (EWIS_INTR_STAT2.UNEQP_STAT) is also available. This event can propagate an interrupt to either WIS_INTA or WIS_INTB, based on the mask enable bits EWIS_INTR_MASKA_2.UNEQP_MASKA and EWIS_INTR_MASKB_2.UNEQP_MASKB.

If the accepted value is not an unequipped label (0x00) and it differs from the programmed expected value, EWIS_MODE_CTRL.C2_EXP, then a path label mismatch (WIS_STAT3.PLMP) is asserted. Similarly the EWIS_INTR_PEND1.PLMP_PEND event is asserted until read. This event can propagate an interrupt to either WIS_INTA or WIS_INTB, based on the mask enable bits EWIS_INTR_MASKA_1.PLMP_MASKA and EWIS_INTR_MASKB_1.PLMP_MASKB.

Although PLMP is not a path level defect, it does cause a change in the setting of one of the ERDI-P codes. For more information, see [Table 13](#), page 28.

3.3.5.4 Remote Path Error Indication (G1)

The most significant four bits of the G1 octet are used for back reporting the number of B3 block errors received at the near-end. This is typically known as path remote error indication (REI-P). The value in this octet comes from the B3 error FIFO. The WIS standard defines a 16-bit REI-P counter, register WIS_REIP_CNT. The WIS standard defines this counter to operate as a block counter as opposed to an individual errored bit counter. This counter is non-saturating and so rolls over after its maximum count. The counter does not clear upon a read, but instead only upon reset as defined in the WIS specification. When the counter is nonzero, the EWIS_INTR_PEND2.REIP_PEND event register is asserted until read. A non-latch high version of this event EWIS_INTR_STAT2.REIP_STAT is also available. This event may propagate an interrupt to either WIS_INTA or WIS_INTB, based on the mask enable bits EWIS_INTR_MASKA_2.REIP_MASKA and EWIS_INTR_MASKB_2.REIP_MASKB, respectively.

An additional 32-bit REI-P counter is provided at REIP_ERR_CNT (EWIS_REIP_CNT1 and EWIS_REIP_CNT0), which is a saturating counter, and is latched and cleared based upon a PMTICK event. Errors are accumulated since the previous PMTICK event. When the counter is nonzero, the EWIS_INTR_PEND2.REIP_NZ_PEND event register is asserted until read. A non-latch high version of this event (EWIS_INTR_STAT2.REIP_NZ_STAT) is also available. This event may propagate an interrupt to either WIS_INTA or WIS_INTB, based on the mask enable bits EWIS_INTR_MASKA_2.REIP_NZ_MASKA and EWIS_INTR_MASKB_2.REIP_NZ_MASKB, respectively.

The REIP_ERR_CNT may optionally be configured to increment on a block count basis, a maximum increment of 1 per errored frame, regardless of the number of errors received. This mode is enabled by asserting EWIS_CNT_CFG.REIP_BLK_MODE.

3.3.5.5 Path Status (G1)

In addition to back-reporting the far-end B3 BIP-8 error count, the G1 octet carries status information from the far-end device known as path remote defect indicator (RDI-P). T1.416 allows either support of 1-bit RDI-P or 3-bit ERDI-P, but indicates ERDI-P is preferred. The VSC8489-02 device supports both modes and may be independently configured for the Rx and Tx directions by configuring EWIS_MODE_CTRL.RX_ERDI_MODE and EWIS_TXCTRL2.ERDI_TX_MODE. ERDI-P is the default for both directions.

The following tables show the different structures for this octet.

Table 11 • Path Status (G1) Byte for RDI-P Mode

G1 REI (B3)				RDI-P	Reserved	Spare	
1	2	3	4	5	6	7	8
Remote Error Indicator count from B3 (0–8 value)				Remote Defect indicator	Set to 00 by transmitter	Ignored by receiver	

Table 12 • Path Status (G1) Byte for ERDI-P Mode

G1 REI (B3)				ERDI-P	Spare		
1	2	3	4	5	6	7	8
Remote Error Indicator count from B3 (0–8 value)				Enhanced Remote Defect Indicator (see following table)	Ignored by receiver		

Enhanced RDI is defined for SONET-based systems as listed in GR-253-CORE (Issue 3), reproduced here in the following table, and as a possible enhancement of SDH-based systems (G.707/Y.1322 (10/2000) Appendix VII (not an integral part of that recommendation)).

Table 13 • RDI-P and ERDI-P Bit Settings and Interpretation

G1 Bits 5, 6, and 7	Priority of ERDI-P Codes	Trigger	Interpretation
000/011	Not applicable	No defects.	No RDI-P defect
100/111	Not applicable	Path alarm indication signal (AIS-P). The remote device sends all ones for H1, H2, H3, and the entire STS SPE. Path loss of pointer (LOP-P).	One-bit RDI-P defect
001	4	No defects.	No ERDI-P defect
010	3	Path label mismatch (PLM-P). Path loss of code group delineation (LCD-P).	ERDI-P payload defect
101	1	Path alarm indication signal (AIS-P). The remote device sends all ones for H1, H2, H3 and entire STS SPE. Path loss of pointer (LOP-P).	ERDI-P server defect
110	2	Path unequipped (UNEQ-P). The received C2 byte is 0x00. Path trace identifier mismatch (TIM-P). This error is not automatically generated, but can be forced using MDIO.	ERDI-P connectivity defect

In the receive direction, with EWIS_MODE_CTRL.RX_ERDI_MODE = 0, an RDI-P defect is the occurrence of the RDI-P signal in ten contiguous frames. An RDI-P defect terminates when no RDI-P signal is detected in ten contiguous frames. An RDI-P event asserts EWIS_INTR_PEND2.FERDIP_PEND until read. A non-latch high version of the far-end RDI-P status can be found in EWIS_INTR_STAT2.FERDIP_STAT. This event may propagate an interrupt to either WIS_INTA or WIS_INTB, based on the mask enable bits EWIS_INTR_MASKA_2.FERDIP_MASKA and EWIS_INTR_MASKB_2.FERDIP_MASKB.

When EWIS_MODE_CTRL.RX_ERDI_MODE = 1, an ERDI-P defect is the occurrence of any one of three ERDI-P signals in ten contiguous frames. An ERDI-P defect terminates when no ERDI-P signal is detected in ten contiguous frames.

The 010 code triggers the latch high register bit WIS_STAT3.FEPLMP_LCDP. It also asserts EWIS_INTR_PEND1.FEPLMP_LCDP_PEND until read. This event may propagate an interrupt to either WIS_INTA or WIS_INTB, based on the mask enable bits EWIS_INTR_MASKA_1.FEPLMP_LCDP_MASKA and EWIS_INTR_MASKB_1.FEPLMP_LCDP_MASKB, respectively.

The 101 code triggers the latch high register bit WIS_STAT3.FEAISP_LOPP. It also asserts EWIS_INTR_PEND1.FEAISP_LOPP_PEND until read. This event may propagate an interrupt to either WIS_INTA or WIS_INTB, based on the mask enable bits EWIS_INTR_MASKA_1.FEAISP_LOPP_MASKA and EWIS_INTR_MASKB_1.FEAISP_LOPP_MASKB, respectively.

The 110 code asserts the EWIS_INTR_PEND2.FEUNEQP_PEND until read. A non-latch-high version of this register (EWIS_INTR_STAT2.FEUNEQP_STAT) is also available. This event may propagate an interrupt to either WIS_INTA or WIS_INTB, based on the mask enable bits EWIS_INTR_MASKA_2.FERDIP_MASKA and EWIS_INTR_MASKB_2.FERDIP_MASKB, respectively.

3.3.5.6 Path User Channel (F2)

The WIS standard does not support the F2 octet and recommends transmitting 0x00 in place of the F2 octet. A value other than 0x00 may be transmitted by programming the intended value at EWIS_TX_K2_F2.TX_F2.

3.3.5.7 Multi-frame Indicator (H4)

The WIS standard does not support the H4 multi-frame octet and recommends transmitting 0x00 in place of the H4 octet. A value other than 0x00 may be transmitted by programming the intended value at EWIS_TX_D6_H4.TX_H4.

3.3.5.8 Reserved for Path Growth (Z3-Z4)

The WIS standard does not support the Z3-Z4 octets and recommends transmitting 0x00 in their place. A value other than 0x00 may be transmitted by programming the intended value at EWIS_TX_D9_Z3.TX_Z3 and EWIS_TX_D12_Z4.TX_Z4 respectively.

3.3.5.9 Tandem Connection Maintenance/Path Data Channel (N1)

The WIS standard does not support the N1 octet and recommends transmitting 0x00 in place of the N1 octet. A value other than 0x00 may be transmitted by programming the intended value at EWIS_TX_N1.TX_N1.

3.3.5.10 Loss of Code Group Delineation

After the overhead is stripped, the payload is passed to the PCS. If the PCS block loses synchronization and cannot delineate valid code groups, the PCS passes a loss of code group delineation (LCD-P) alarm to the WIS. This alarm triggers the latch high register bit WIS_STAT3.LCDP. It also asserts EWIS_INTR_PEND1.LCDP_PEND until read. This event may propagate an interrupt to either WIS_INTA or WIS_INTB, based on the mask enable bits EWIS_INTR_MASKA_1.LCDP_MASKA and EWIS_INTR_MASKB_1.LCDP_MASKB, respectively.

The WIS specification calls for a LCD-P defect persisting continuously for more than 3 ms to be back reported to the far-end. Upon device reset, a LCD-P is back reported until the PCS signals that valid code groups are being delineated. The LCD-P defect deasserts (and is not back reported) after the condition is absent continuously for at least 1 ms.

3.3.5.11 Reading Statistical Counters

The VSC8489-02 device contains several counters that may be read using the MDIO interface. For each error count, there are two sets of counters. The first set is the standard WIS counter implemented according to IEEE 802.3ae, and the second set is for statistical counts using PMTICK.

To read the IEEE 802.3ae counters, the station manager must read the most significant register of the 32-bit counter first. This read action latches the internal error counter value into the MDIO readable registers. A subsequent read of the least significant register does not latch new values, but returns the value latched at the time of the most significant register read.

It may be difficult to get a clear picture of the timeframes in which errors were received because the IEEE 802.3ae counters are independently latched. The PMTICK counters are all latched together, thereby providing a complete snapshot in time. When PMTICK is asserted, the internal error counter values are copied into their associated registers and the internal counters are reset.

There are three methods of asserting PMTICK.

- The station manager may asynchronously assert EWIS_PMTICK_CTRL.PMTICK_FRC to latch the values at a given time, regardless of the EWIS_PMTICK_CTRL.PMTICK_ENA setting.
- The VSC8489-02 device may be configured to latch and clear the statistical counters at a periodic interval as determined by the timer (count) value in EWIS_PMTICK_CTRL.PMTICK_DUR. In this mode, the EWIS_PMTICK_CTRL.PMTICK_SRC must be configured for internal mode and the EWIS_PMTICK_CTRL.PMTICK_ENA bit must be asserted. The receive path clock is used to drive the PMTICK counter, thus the periodicity of the timer can vary during times of loss of lock and loss of frame.
- The VSC8489-02 device may be configured to latch and clear the statistical counters at the occurrence of a rising edge detected at a GPIO pin configured as a PMTICK input pin. In this mode, the EWIS_PMTICK_CTRL.PMTICK_SRC bit must be deasserted, and the EWIS_PMTICK_CTRL.PMTICK_ENA must be asserted. Corresponding GPIO must be configured as the PMTICK input pin.

Regardless of EWIS_PMTICK_CTRL.PMTICK_SRC, when the PMTICK event occurs, the EWIS_INTR_PEND2.PMTICK_PEND is asserted until read. This event may propagate an interrupt to either WIS_INTA or WIS_INTB, based on the mask enable bits EWIS_INTR_MASKA_2.PMTICK_MASKA and EWIS_INTR_MASKB_2.PMTICK_MASKB, respectively.

Given the size of the error counters and the maximum allowable error counts per frame, care must be taken in the frequency of polling the registers to ensure accurate values. All PMTICK counters saturate at their maximum values.

Table 14 • PMTICK Counters

Counter Name	Description	Registers	Maximum Increase Count Per Frame	Maximum Increase Count Per Second	Time Until Overflow
B1_ERR_CNT	B1 section error count	EWIS_B1_ERR_CNT1 EWIS_B1_ERR_CNT0	8	64,000	67,109
B2_ERR_CNT	B2 line error count	EWIS_B2_ERR_CNT1 EWIS_B2_ERR_CNT0	1536	12,288,000	350
B3_ERR_CNT	B3 path error count	EWIS_B3_ERR_CNT1 EWIS_B3_ERR_CNT0	8	64,000	67,109
EWIS_REIP_CNT	Far-end B3 path error count	EWIS_REIP_CNT1 EWIS_REIP_CNT0	8	64,000	67,109
EWIS_REIL_CNT	Far-end B2 line error count	EWIS_REIL_CNT1 EWIS_REIL_CNT0	1536	12,288,000	350

Both individual and block mode accumulation of B1, B2, and B3 error indications are supported and selectable using the control bits EWIS_CNT_CFG.B1_BLK_MODE, EWIS_CNT_CFG.B2_BLK_MODE, and EWIS_CNT_CFG.B3_BLK_MODE. In individual accumulation mode 0, the counter is incremented for each bit mismatch between the calculated B1, B2, and/or B3 error and the extracted B1, B2, and/or B3. In block accumulation mode 1, the counter is incremented only once for any nonzero number of bit mismatches between the calculated B1, B2, and/or B3 and the extracted B1, B2, and/or B3 (maximum of one error per frame).

3.3.6 Defects and Anomalies

All defects and anomalies listed in the following table can be forced and masked by the user. The VSC8489-02 device does not automatically generate TIM-P, but does support forcing defects using MDIO.

Table 15 • Defects and Anomalies

Defect or Anomaly	Description	Type	Force Bit	Status Bit
Far-end PLM-P or LCD-P	These two errors are indistinguishable when reported by the far-end through the G1 octet (ERDI-P), because the far-end reports both PLM-P and LCD-P with the same error code.	Far-end defect	EWIS_RX_ER R_FRC2.FRC_ RX_FE_PLMP	WIS_STAT3. FEPLMP_LC DP
Far-end AIS-P or LOP-P	These two errors are indistinguishable when reported by the far-end through the G1 octet (ERDI-P), because the far-end reports both AIS-P and LOP-P with the same error code.	Far-end defect	EWIS_RX_ER R_FRC2.FRC_ RX_FE_AISP	WIS_STAT3. FEAISP_LOP P
PLM-P	Path label mismatch. The detection and reporting of the PLM-P defect follows section 7.5 of ANSI T1.416-1999.	Near-end defect; propagated to PCS	EWIS_RX_ER R_FRC2.FRC_ RX_PLMP	WIS_STAT3. PLMP
AIS-L	Generated on LOPC, LOS, LOF, if enabled by EWIS_RXTX_CTRL.RXAISL_ON_LOPC, EWIS_RXTX_CTRL.RXAISL_ON_LOS, EWIS_RXTX_CTRL.RXAISL_ON_LOF, or when forced by user.	Near-end defect	The AIS-L defect is only processed and reported by the WIS Receive process; it is never transmitted by the WIS Transmit process, according to IEEE 802.3ae.	EWIS_RX_E RR_FRC1.F RC_RX_AISL /WIS_STAT3. AISL
AIS-P	Path alarm indication signal.	Near-end defect; propagated to PCS	EWIS_RX_ER R_FRC1.FRC_ RX_AISP	WIS_STAT3. AISP
LOP-P	Path loss of pointer. Nine consecutive invalid pointers result in loss of pointer detection. See Figure 13 , page 24 for the pointer interpreter state machine.	Near-end defect; propagated to PCS	EWIS_RX_ER R_FRC1.FRC_ RX_LOP	WIS_STAT3. LOPP
LCD-P	Path loss of code group delineation. See Table 13 , page 28. This is also reported to the far-end if it persists for at least 3 ms.	Near-end defect	EWIS_RX_ER R_FRC2.FRC_ LCDP	WIS_STAT3. LCDP
LOPC	Loss of optical carrier alarm. This is an input from the XFP module's loss of signal output. The polarity can be inverted for use with other module types. This defect can be used independently or in place of LOS.	Near-end defect	EWIS_RX_ER R_FRC1.FRC_ LOPC	EWIS_INTR_ STAT2.LOPC _STAT

Table 15 • Defects and Anomalies (continued)

Defect or Anomaly	Description	Type	Force Bit	Status Bit
LOS	The PMA circuitry detects a loss of signal (LOS) defect if the input signal falls below the assert threshold. When a PMA LOS is declared the framer is held in reset to prevent it from looking for a frame boundary.	Near-end defect	EWIS_RX_ER R_FRC1.FRC_ LOS	WIS_STAT3. LOS
SEF	Severely errored frame. Generated when device cannot frame to A1 A2 pattern. SEF indicates synchronization process is not in the SYNC state, as defined by the state diagram of IEEE 802.3ae clause 50.4.2.	Near-end defect; propagated to PCS	EWIS_RX_ER R_FRC2.FRC_ RX_SEF	WIS_STAT3. SEF
LOF	Generated when SEF persists for 3 ms. Terminated when no SEF occurs for 1 ms to 3 ms.	Near-end defect	EWIS_RX_ER R_FRC2.FRC_ RX_LOF	WIS_STAT3. LOF
B1 PMTICK error count is nonzero	BIP-N(S) - 32-bit near-end section BIP error counter is nonzero.	Near-end anomaly	EWIS_RX_ER R_FRC2.FRC_ RX_B1	EWIS_INTR_ STAT2.B1_N Z_STAT
B2 PMTICK error count is nonzero	BIP-N(L) - 32-bit near-end line BIP error counter is nonzero.	Near-end anomaly	EWIS_RX_ER R_FRC2.FRC_ RX_B2	EWIS_INTR_ STAT2.B2_N Z_STAT
B3 PMTICK error count is nonzero	BIP-N(P) - 32-bit near-end path BIP error counter is nonzero.	Near-end anomaly	EWIS_RX_ER R_FRC2.FRC_ RX_B3	EWIS_INTR_ STAT2.B3_N Z_STAT
REI-L	Line remote error indicator octet is nonzero. Far-end BIP-N(L).	Far-end anomaly	EWIS_RX_ER R_FRC2.FRC_ RX_REIL	EWIS_INTR_ STAT2.REIL_ STAT
REI-L PMTICK error count is nonzero	Line remote error indicator is nonzero. Far-end BIP-N(L).	Far-end anomaly	EWIS_RX_ER R_FRC2.FRC_ REIL	EWIS_INTR_ STAT2.REIL_ NZ_STAT
RDI-L	Line remote defect indicator.	Far-end defect	EWIS_RX_ER R_FRC1.FRC_ RX_RDIL	WIS_STAT3. RDIL
REI-P	Path remote error indicator octet is nonzero. Far-end BIP-N(P).	Far-end anomaly	EWIS_RX_ER R_FRC2.FRC_ RX_REIP	EWIS_INTR_ STAT2.REIP_ STAT
REI-P PMTICK error count is nonzero	Path remote error indicator. Far-end BIP-N(P).	Far-end anomaly	EWIS_RX_ER R_FRC2.FRC_ REIP	EWIS_INTR_ STAT2.REIP_ NZ_STAT
UNEQ-P	Unequipped path.	Near-end defect	EWIS_RX_ER R_FRC2.FRC_ RX_UNEQP	EWIS_INTR_ STAT2.UNEQ P_STAT
Far-end UNEQ-P	Far-end unequipped path.	Far-end defect	EWIS_RX_ER R_FRC2.FRC_ RX_FE_UNEQ P	EWIS_INTR_ STAT2.FEUN EQP_STAT

3.3.7 Interrupt Pins and Interrupt Masking

The VSC8489-02 device generates interrupts for each defect and anomaly. The interrupts for the BIP error counts (B1, B2, and B3 counters) and the interrupts for the far-end error counts (REI-L and REI-P)

are generated when the PMTICK counters become nonzero. Mask enable bits propagate the interrupt pending event to GPIO pins configured as WIS_INTA and WIS_INTB. Each event may be optionally masked for each WIS_INTA/B pin.

The WIS_INTA and WIS_INTB signals are routed off-chip through GPIO pins. Many specialized functions share the GPIO pins. The WIS_INTA and WIS_INTB signals do not go to dedicated pins.

For each defect or anomaly defined in IEEE 802.3ae, the VSC8489-02 device supports the standard WIS register. In addition, the VSC8489-02 device supports another set of registers in the WIS Vendor Specific area. These registers provide a STATUS bit to indicate the current real-time status of the event, a PENDING bit to indicate if the STATUS bit has changed state, and two mask enable bits for each interrupt pin (WIS_INTA and WIS_INTB). The STATUS bit is set if and only if the interrupt currently exists. This STATUS bit does not latch.

The defects and anomalies are constructed in a hierarchy such that lower order alarms are squelched when higher order events are detected. For more information about the dependencies between squelches and events, see the WIS interrupt registers.

3.3.8 Overhead Serial Interfaces

The VSC8489-02 device includes provisions for off-chip processing of the critical SONET/SDH transport overhead 9-bit words through two independent serial interfaces. The transmit overhead serial interface (TOSI) is used to insert 9-bit words into the transmit frames, and the receive overhead serial interface (ROSI) is used to recover the 9-bit words from the received frames. Each interface consists of three pins: a clock output, a frame pulse output, and a data input (Tx) /output (Rx). These I/O are LVTTTL compatible for easy connection to an external device such as an FPGA.

Note: Extended WIS TOSI and ROSI do not support path overhead bytes.

The TOSI / ROSI signals are routed off-chip through GPIO pins. If the ROSI/TOSI interfaces are to be used, there are no GPIO pins left in the design for any other function—loss-of-lock for Sync-E applications, activity LED drivers, WIS_interruptions, or two-wire serial (slave) interface.

All references to TCLKOUT, TFPOUT, TDAIN, RCLKOUT, RFPOUT and RDAOUT are the TOSI/ROSI signals routed through GPIO pins.

3.3.8.1 Transmit Overhead Serial Interface (TOSI)

The TOSI port enables the user to individually program 222 separate 9-bit words in the SONET/SDH overhead. The SONET/SDH frame rate is 8 kHz as signaled by the frame pulse (TFPOUT) signal. The TOSI port is clocked from a divided-down version of the WIS transmit clock made available on TCLKOUT. To provide a more standard clock rate, 9-bit dummy words are added per frame, resulting in a clock running at one five-hundred-twelfth of the line rate (or 19.44 MHz). For each 9-bit word, the external device indicates the desire to transmit that byte by using an enable indicator bit (EIB) that is appended to the beginning of the 9-bit word. If EIB = 0, the data on the serial interface is ignored for that overhead 9-bit word. If EIB = 1, the serial interface data takes precedence over the value generated within the VSC8489-02 device. The EIB is present before the 9-bit dummy words too, however its value has no effect as the 9-bit dummy words are ignored within the device. The first EIB bit should be transmitted by the external device on the first rising edge of TCLKOUT after TFPOUT, as shown in the following illustration. The data should be provided with the most significant bit (MSB) first. After reception of the TOSI data for a complete frame, the values are placed in the overhead for the next transmitted frame.

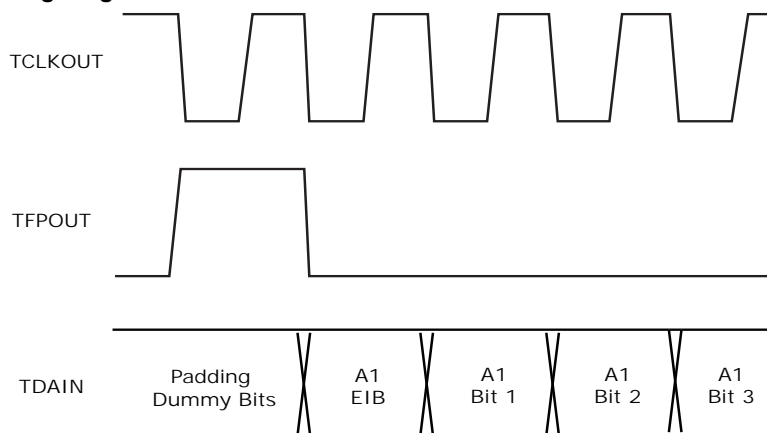
Figure 14 • TOSI Timing Diagram

Some 9-bit words are error masks, such that the transmitted 9-bit word is the XOR of the TOSI 9-bit word and the pre-defined value within the chip if the EIB is enabled. This feature is best used for test purposes only.

The order of the 9-bit word required by the TOSI port is summarized in the following table, where the number of registers is the number of bytes on the serial interface and the number of bytes is the number of STS channels on which the byte is transmitted. For H1 and H2 pointers, bytes 2 to 192 are concatenation indication bytes consistent with STS-192c frames. There are not 192 different point locations as in STS-192 frames.

Table 16 • TOSI/ROSI Addresses

Byte Name	9-Bit Word	TOSI/ROSI Byte Order	Number of Registers	Number of Bytes	Type
Frame boundary	A1	0	1	192	Programmable byte that is identical for all locations
Frame boundary	A2	1	1	192	Programmable byte that is identical for all locations
Section trace	J0	2	1	1	Programmable byte
Section growth	Z0	3	1	191	Programmable byte that is identical for all locations
Dummy byte		4	1	1	Programmable byte
Section BIP-8	B1	5	1	1	TOSI inserts error mask; ROSI extracts XOR of B1 value and received data
Orderwire	E1	6	1	1	Programmable byte
Section user channel	F1	7	1	1	Programmable byte
Dummy byte		8	1	1	Programmable bytes
Section DCC 1	D1	9	1	1	Programmable byte
Section DCC 2	D2	10	1	1	Programmable byte
Section DCC 3	D3	11	1	1	Programmable byte
Dummy byte		12	1	1	Programmable byte
Pointer 1	H1	13	1	1	Programmable byte affecting the first H1 byte

Table 16 • TOSI/ROSI Addresses (continued)

Byte Name	9-Bit Word	TOSI/ROSI Byte Order	Number of Registers	Number of Bytes	Type
Pointer 2	H2	14	1	1	Programmable byte affecting the first H2 byte
Pointer action	H3	15	1	192	Programmable byte that is identical for all locations
Dummy byte		16	1	1	Programmable byte
Line BIP-8	B2	17 to 208	192	192	TOSI inserts error mask for each byte; ROSI extracts XOR of B2 value and received data for each byte
Automatic protection switching (APS) channel and remote defect indicator (RDI)	K1	209	1	1	Programmable byte
Automatic protection switching (APS) channel and remote defect indicator (RDI)	K2	210	1	1	Programmable byte
Dummy byte		211	1	1	Programmable byte
Line DCC 4	D4	212	1	1	Programmable byte
Line DCC 5	D5	213	1	1	Programmable byte
Line DCC 6	D6	214	1	1	Programmable byte
Dummy byte		215	1	1	Programmable byte
Line DCC 7	D7	216	1	1	Programmable byte
Line DCC 8	D8	217	1	1	Programmable byte
Line DCC 9	D9	218	1	1	Programmable byte
Dummy byte		219	1	1	Programmable byte
Line DCC 10	D10	220	1	1	Programmable byte
Line DCC 11	D11	221	1	1	Programmable byte
Line DCC 12	D12	222	1	1	Programmable byte
Dummy byte		223	1	1	Programmable byte
Synchronization message	S1	224	1	1	Programmable byte
Growth 1	Z1	225	1	191	Programmable byte that is identical for all locations
Growth 2	Z2	226	1	190/191	Programmable byte that is identical for all locations; dependent upon 2xEC40.12
STS-1 REI-L	M0	227	1	1	Programmable byte
STS-N REI-L	M1	228	1	1	Programmable byte
Orderwire 2	E2	229	1	1	Programmable byte
Dummy byte		230	1	1	Programmable byte

Table 16 • TOSI/ROSI Addresses (continued)

Byte Name	9-Bit Word	TOSI/ROSI Byte Order	Number of Registers	Number of Bytes	Type
Padding dummy bytes		231 to 269	39		No function

3.3.8.2 Receive Overhead Serial Interface (ROSI)

The ROSI port extracts the same 222 overhead 9-bit words from the SONET/SDH frame, and consists of the clock output (RCLKOUT), frame pulse output (RFPOUT), and data output (RDAOUT). The ROSI port is clocked from a divided-down version of the WIS receive clock, and is valid during in-frame conditions only. As with the TOSI port, 9-bit dummy words are provided each frame period resulting in a 19.44 MHz RCLKOUT frequency. For each 9-bit word, including the 9-bit dummy words, an extra 0 bit is added at the beginning of each byte so that the TOSI and ROSI clock rates are identical. The first stuff bit for each frame is transmitted by RDAOUT on the first rising edge of RCLKOUT after the frame pulse (RFPOUT), as shown in the following illustration.

Because the receive path overhead can be split across two frames, the VSC8489-02 device buffers the overhead for an additional frame time so that a complete path overhead is presented. Table 16, page 34 outlines the order for each of the 9-bit words presented on the ROSI port. With the exception of the M0/M1 9-bit words, the extracted 9-bit words are from the first channel position. In place of parity and error 9-bit words, the VSC8489-02 device outputs the result of an XOR between the calculated BIP and the received value. Therefore, a count of ones within each of the BIP 9-bit words should correspond with the internal error accumulators. The following illustration shows the functional timing for the ROSI port.

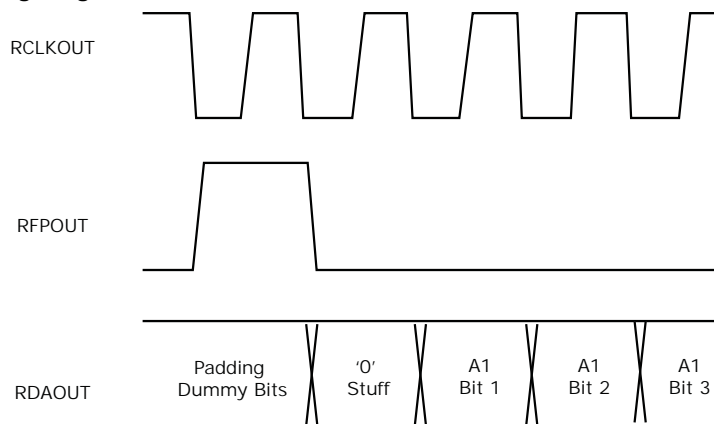
Figure 15 • ROSI Timing Diagram

3.3.9 Pattern Generator and Checker

The VSC8489-02 device implements the square wave, PRBS31, and mixed-frequency test patterns as described in section 50.3.8 of IEEE 802.3ae as well as the test signal structure (TSS) and continuous identical digits (CID) pattern.

The square wave pattern is selected asserting WIS_CTRL2.TEST_PAT_SEL and the generator is enabled by asserting WIS_CTRL2.TEST_PAT_GEN. When WIS_CTRL2.TEST_PAT_SEL is deasserted, the mixed frequency test pattern is selected. The square wave frequency is configured according to EWIS_TXCTRL2.SQ_WV_PW. The WIS_CTRL2.TEST_PAT_ANA bit is used to enable the test pattern checker in the receive path. The checker does not operate on square wave receive traffic. Error counts from the mixed frequency pattern are presented in the SONET/SDH BIP-8 counters, B1_CNT, WIS_B1_CNT, WIS_B2_CNT, and WIS_B3_CNT.

The VSC8489-02 device supports the PRBS31 test pattern as reflected in WIS_STAT2.PRBS31_ABILITY. The transmitter/generator is enabled by asserting

WIS_CTRL2.TEST_PRBS31_GEN, while the receiver/checker is enabled by asserting WIS_CTRL2.TEST_PRBS31_ANA. Because the mixed frequency/square wave test patterns have priority over the PRBS31 pattern, WIS_CTRL2.TEST_PAT_GEN must be disabled for the PRBS31 test pattern to be sent. Error counts from the PRBS31 checker are available in WIS_TSTPAT_CNT. This register does not roll over after reaching its maximum count and is cleared after every read operation. Two status bits are available from the PRBS checker. The EWIS_PRBS31_ANA_STAT.PRBS31_ERR bit indicates whether the error counter is nonzero. The EWIS_PRBS31_ANA_STAT.PRBS31_ANA_STATE bit if asserted indicates that checker is synchronized and actively checking received bits. For test purposes, the PRBS generator can inject single bit errors. By asserting EWIS_PMTICK_CTRL.PMTICK_SRC, a single bit error is injected, resulting in three bit errors being detected within the checker. The value of three comes from the specification, which indicates one error should be detected for each tap within the checker.

3.4 10G Physical Coding Sublayer (64B/66B PCS)

The 10G physical coding sublayer (PCS) is defined in IEEE 802.3ae Clause 49. It is composed of the PCS transmit, PCS receive, block synchronization, and BER monitor processes. The PCS functions can be further broken down into encode or decode, scramble or descramble, and gearbox functions, as well as various test and loopback modes.

The PCS is responsible for transferring data between the XAUI clock domain and the WIS/PMA clock domain. In addition, the PCS encodes and scrambles the data for efficient transport across the given medium.

The following illustration provides a block diagram of the 10G PCS block.

Figure 16 • PCS Block Diagram

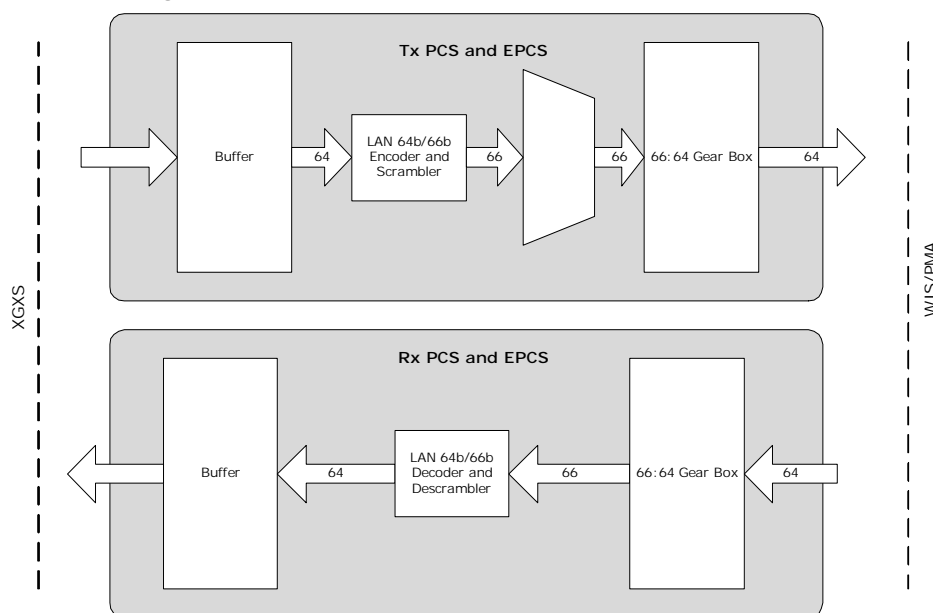

3.4.1 Control Codes

The VSC8489-02 device supports the use of all control codes and ordered sets necessary for 10 GbE and 10 GFC operation. The following table lists the control characters, notation, and control codes.

Table 17 • Control Codes

Control Codes	Control Character	Notation ¹	XGMII Control Code	10-G BASE-R Control Code	10-G BASE-R O Code
8b/10b Code ²	Idle	/I/	0x07	0x00	
K28.0 or	K28.3 or	K28.5	Start	/S/	0xfb

Table 17 • Control Codes (continued)

Control Codes (continued)	Control Character	Notation ¹	XGMII Control Code	10-G BASE-R Control Code	10-G BASE-R O Code
Encoded by block type field		K27.7	Terminate	/T/	0xfd
Encoded by block type field		K29.7	Error	/E/	0xfe
0x1e		K30.7	Sequence ordered_set	/Q/	0x9c
Encoded by block type field plus O code	0x0	K28.4	Reserved 0	/R/	0x1c
0x2d		K28.0	Reserved 1		0x3c
0x33		K28.1	Reserved 2	/A/	0x7c
0x4b		K28.3	Reserved 3	/K/	0xbc
0x55		K28.5	Reserved 4		0xdc
0x66		K28.6	Reserved 5		0xf7
0x78		K23.7	Signal ordered_set ³	/Fsig/	0x5c
Encoded by block type field plus O code	0xF	K28.2			

1. The codes for /A/, /K/ and /R/ are used on the XAUI interface to signal idle.
2. For information only. The 8b/10b code is specified in Clause 36. Usage of the 8b/10b code for 10 Gbps operation is specified in Clause 4.
3. Reserved for INCITS T11 - 10 GFC μ s.

3.4.2 Transmit Path

In the transmit direction, the PCS accepts data from the XGXS interface, which runs off the XAUI recovered clock and transfers the data onto the PMA transmit clock domain, through the rate-disparity compensating FIFO. Based on the FIFO's fill level, idle characters are added or removed as needed.

Once in the PMA clock domain, the de-serialized XAUI input data (64-bit) is checked for validity. Transmitted data is handled according to IEEE 802.3ae Clause 49.

The characters are then processed in a two-step manner. First, the 64 bits are encoded and a 2-bit header is calculated to form a single 66-bit block. The two header bits are used for block delineation and classification. The only valid header codes are 01 to indicate a payload of all data octets and 10 to indicate the presence of one or more control characters within the payload. To maintain a DC balanced signal on the serial line, the 64-bit encoded payload is scrambled using a self-synchronizing scrambler that implements the polynomial $G(x) = 1 + x^{39} + x^{58}$. The header bits are not scrambled as they are already DC balanced. For debug purposes, the scrambler can be disabled by deasserting SCR_DIS (3x8005.9).

The 66-bit blocks are then passed to the PMA through a 66:64 gearbox. The gearbox merely feeds the 66-bit data into the WIS/PMA's 64-bit data path.

3.4.3 Receive Path

In the receive direction, the PCS accepts data from the WIS/PMA block and reformats it for transmission to the XGXS interface. Because of the data path width mismatches between the WIS/PMA and the PCS, a 64:66 gearbox is needed. The gearbox also performs block synchronization/alignment based upon the 2-bit synchronization header. When the receive logic receives 64 continuous valid sync headers, the BLOCK_LOCK (3x0021.15) bit is asserted. This bit is a latch-low bit; therefore, a second read of the bit returns the current status. If 16 invalid block sync headers are detected within a 125 μ s period, the

PCS_HIGHBER (3x0021.14) bit is asserted. This bit is a latch-high bit, and therefore a second read of the bit returns the current status.

Once block synchronization is achieved, the occurrence of errored blocks are accumulated in the PCS_ERRORED_BLOCKS (3x0021.7:0) counter. An errored block is one that has one or more of the following defects:

- The sync field has a value of 00 or 11.
- The block type field contains a reserved value (for more information, see Table 17, page 37).
- Any control character contains an incorrect value.
- Any O code contains an incorrect value.
- The set of eight XGMII characters does not have a corresponding block format shown in the following illustration.

Figure 17 • 64B/66B Block Formats

Input Data	Sync	Block Payload									
Bit Position :	0 1 2	65									
Data Block Format :											
D0 D1 D2 D3/D4 D5 D6 D7	01	D ₀	D ₁	D ₂	D ₃	D ₄	D ₅	D ₆	D ₇		
Control Block Formats :		Block Type Field									
C0 C1 C2 C3/C4 C5 C6 C7	10	0x1e	C ₀	C ₁	C ₂	C ₃	C ₄	C ₅	C ₆	C ₇	
C0 C1 C2 C3/O4 D5 D6 D7	10	0x2d	C ₀	C ₁	C ₂	C ₃	O ₄	D ₅	D ₆	D ₇	
C0 C1 C2 C3/S4 D5 D6 D7	10	0x33	C ₀	C ₁	C ₂	C ₃	O ₄	D ₅	D ₆	D ₇	
O0 D1 D2 D3/D4 D5 D6 D7	10	0x66	D ₁	D ₂	D ₃	O ₀	O ₄	D ₅	D ₆	D ₇	
O0 D1 D2 D3/O4 D5 D6 D7	10	0x55	D ₁	D ₂	D ₃	O ₀	O ₄	D ₅	D ₆	D ₇	
S0 D1 D2 D3/D4 D5 D6 D7	10	0x78	D ₁	D ₂	D ₃	D ₄	D ₅	D ₆	D ₇		
O0 D1 D2 D3/C4 C5 C6 C7	10	0x4b	D ₁	D ₂	D ₃	O ₀	C ₄	C ₅	C ₆	C ₇	
T0 C1 C2 C3/C4 C5 C6 C7	10	0x87	C ₁	C ₂	C ₃	C ₄	C ₅	C ₆	C ₇		
D0 T1 C2 C3/C4 C5 C6 C7	10	0x99	D ₀	C ₂	C ₃	C ₄	C ₅	C ₆	C ₇		
D0 D1 T2 C3/C4 C5 C6 C7	10	0xaa	D ₀	D ₁	C ₃	C ₄	C ₅	C ₆	C ₇		
D0 D1 D2 T3/C4 C5 C6 C7	10	0xb4	D ₀	D ₁	D ₂	C ₄	C ₅	C ₆	C ₇		
D0 D1 D2 D3/T4 C5 C6 C7	10	0xcc	D ₀	D ₁	D ₂	D ₃	C ₅	C ₆	C ₇		
D0 D1 D2 D3/D4 T5 C6 C7	10	0xd2	D ₀	D ₁	D ₂	D ₃	D ₄	C ₆	C ₇		
D0 D1 D2 D3/D4 D5 T6 C7	10	0xe1	D ₀	D ₁	D ₂	D ₃	D ₄	D ₅	C ₇		
D0 D1 D2 D3/D4 D5 D6 T7	10	0xff	D ₀	D ₁	D ₂	D ₃	D ₄	D ₅	D ₆		

Valid blocks recover their original payload data by being descrambled. The descrambler is the same polynomial used by the transmitter. For test purposes, the descrambler may be disabled by asserting DSCR_DIS (3x8005.10). The data is checked for valid characters and sequencing.

The data is passed from the PMA/WIS clock domain to the XAUI clock domain through a FIFO. Based upon the FIFO's fill level, idle characters are added or removed as needed.

3.4.4 PCS Standard Test Modes

The PCS block offers all of the standard defined test pattern generators and analyzers. In addition, the VSC8489-02 device supports a 64-bit static user pattern and the optional PRBS31 pattern. Two error counters are available. Each is a saturating counter that is cleared upon a read operation. The first, PCS_ERR_CNT, is located in the IEEE Standard area while the 32-bit PCS_VSERR_CNT_0/PCS_VSERR_CNT_1 is located in the vendor specific area.

The IEEE specification defines two test pattern modes, a square wave generator and a pseudo-random test pattern. The square wave generator is enabled by first selecting the square wave pattern by asserting PCS_TSTPAT_SEL, and then enabling the test pattern generator, PCS_TSTPAT_GEN. The period of the square wave can be controlled in terms of bit times by writing to PCS_SQPW. There is no associated square wave checker within the VSC8489-02 device.

The pseudo-random test pattern is selected by deasserting PCS_TSTPAT_SEL. The pseudo-random test pattern contains two data modes. When PCS_TSTDAT_SEL is deasserted, the pseudo-random

pattern is a revolving series of four blocks with each block 128-bits in length. The four blocks are the resultant bit sequence produced by the PCS scrambler when pre-loaded with the following seeds:

- PCS_SEEDA_0, PCS_SEEDA_1, PCS_SEEDA_2, PCS_SEEDA_3
- PCS_SEEDA invert
- PCS_SEEDB_0, PCS_SEEDB_1, PCS_SEEDB_2, PCS_SEEDB_3
- PCS_SEEDB invert

The pattern generator is enabled by asserting PCS_TSTPAT_GEN while the analyzer is enabled by asserting PCS_TSTPAT_ANA. Errors are accumulated in the clear-on-read saturating counter, PCS_ERR_CNT. In pseudo-random pattern mode, the error counter counts the number of errored blocks.

Support for the optional PRBS31 pattern is indicated by PRBS31_pattern_testing_ability register whose default is high. The PRBS31 test generator is selected by asserting PCS_PRBS31_GEN, while the checker is enabled by asserting PCS_PRBS31_ENA. IEEE standards specify that the error counter should increment for each linear feedback shift register (LFSR) tap that a bit is in error. Therefore, a single bit error increments the counter by three because there are three taps in the PRBS31 polynomial.

The user-defined 64-bit static pattern can be written to PCS_USRPAT registers and enabled by asserting PCS_USRPAT_ENA and PCS_TSTPAT_GEN. Enabling the user-defined pattern enables both the generator and analyzer.

3.5 1G Physical Coding Sublayer

The 1G physical coding sublayer (PCS) implements 1000BASE-X as specified by IEEE 802.3 Clause 36, and auto-negotiation as specified by IEEE 802.3 Clause 37. It provides for the encoding (and decoding) of GMII data octets to (and from) ten-bit code-groups (8B/10B) for communication with the underlying PMA. It also manages link control and the auto-negotiation process.

In addition to these standard 1000BASE-X functions, the 1G PCS also includes a conversion function that maps the standard GMII data to (and from) an internal XGMII-like interface. This allows the processing core to be largely agnostic to whether a channel is operating in 1G or 10G operation.

3.6 Rate Compensating Buffers

Rate compensating buffers are used in the data paths. The rate compensating buffers add and drop idle characters between ethernet packets when necessary to address clock rate differences between the line-side and host-side interfaces. Rate offsets from ideal frequencies measured in ppm (not MHz) can be tolerated.

The maximum data throughput on the line interface is less in 10G WAN mode than 10G LAN mode. The line's data rate is reduced to 9.953 Gbps from 10.3125 Gbps. Part of that bandwidth includes SONET/SDH frame overhead data.

Note: Care must be taken by the device sending data to the host interface in the egress data path to ensure the rate compensating buffer does not overflow.

3.7 Loopback

The VSC8489-02 device has several options available for routing traffic between the host-side and the line-side. The following table shows the name and location of the loopback modes. These modes may be extremely useful for both test and debug purposes.

Table 18 • Host-Side Loopbacks

Name	Location	Line-Side Tx	Notes
H2	XAUI-PHY interface (1G and 10G)	Mirror XAUI data	1G and 10G modes
H3	PCS after the gearbox (10G)	0xFF00 repeating	IEEE PCS system loopback (10G mode)
H4	WIS-PMA interface (10G)	0xFF00 repeating	IEEE WIS system loopback (10G mode)

Table 19 • Line-Side Loopbacks

Name	Location	Host-Side Tx	Notes
L1	XAUI loopback (10G)	Mirror SFP+ data	IEEE PHY-XS network loopback (1G and 10G modes)
L2	XGMII interface (10G)	Mirror SFP+ data	10G mode
L3	PMA interface (1G and 10G)	Mirror SFP+ data	1G and 10G modes

The following illustration shows the host and line-side loopbacks.

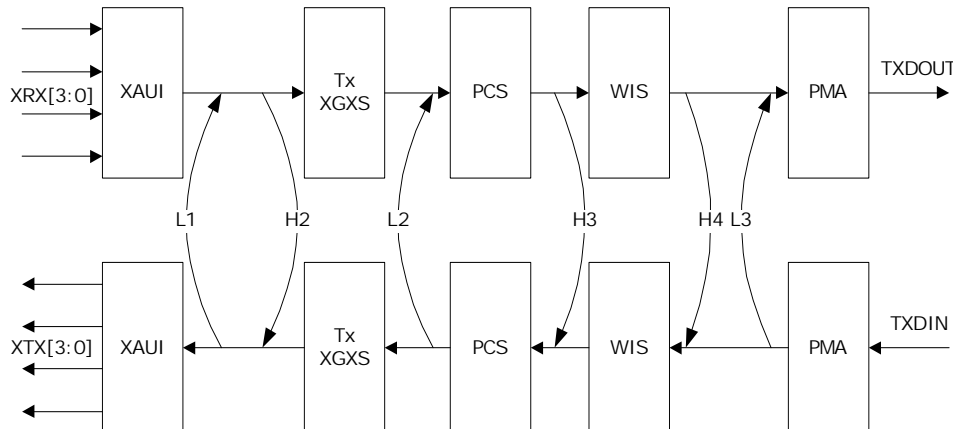
Figure 18 • Host-Side and Line-Side Loopbacks

3.8 Cross-Connect (Non-Hitless Operation)

The VSC8489-02 device features a cross-connect between the two adjacent ports to support protection-switching applications and failover capabilities. It supports cross-connect and line broadcast (bridge and select) to host-side between the two adjacent ports.

In the cross-connect configuration, each port's line-side, which is normally connected to its own port host-side, is connected to the other port's host-side. In a broadcast configuration, a line-side of one port is connected to both port's host-sides.

XAUI interfaces in the VSC8489-02 device support the following failover capabilities:

- Network traffic on Chan0 is switchable between XAUI channel 0 or 1.
- Network traffic on Chan1 is switchable between XAUI channel 1 or 0.

The VSC8489-02 device supports failover and SFI to XAUI broadcasting.

The XAUI data at channel_0 can be routed to either SFI of channel_0 or SFI of channel_1, but not both at the same time. Similarly, the XAUI data at channel_1 can be routed to either SFI of channel_1 or SFI of channel_0, but not both at the same time. However, the SFI data of either channel_0 or channel_1 can be routed to XAUI of channel_0, or XAUI of channel_1, or broadcast to XAUI of both channel_0 and channel_1.

For example, in normal operation, the XAUI of channel_0 is routed to SFI of channel_0. When a problem occurs on the link connecting to SFI of channel_0, re-route the XAUI of channel_0 to SFI of channel_1. Or, if there is a problem at the MAC interfacing to the XAUI of channel_0, re-route the SFI data of channel_0 to XAUI of channel_1. Broadcasting from SFI to both XAUI ports enables the passing of traffic between XAUI of channel_0 and SFI of channel_0, and to use XAUI of channel_1 to snoop the incoming data from SFI of channel_0, if so desired.

The following table lists the available settings for failover/broadcasting modes.

Table 20 • Failover and Broadcasting Modes

Setting	Mode
1Ex0003 =0x00	XAUI channel_0 to/from SFI channel_0 interface XAUI channel_1 from SFI channel_0 interface SFI channel_1 from XAUI channel_1
1Ex0003 = 0x01	XAUI channel_0 from SFI channel_0 interface XAUI channel_1 to/from SFI channel_0 interface SFI channel_1 from XAUI channel_0
1Ex0003 =0x20	XAUI channel_0 to/from SFI channel_0 interface XAUI channel_1 to/from SFI channel_1
1Ex0003 =0x21	XAUI channel_0 from SFI channel_0 XAUI channel_1 from SFI channel_1 SFI channel_0 from XAUI channel_1 SFI channel_1 from XAUI channel_0
1Ex0003 =0x10	XAUI channel_0 from SFI channel_1 XAUI channel_1 from SFI channel_0 SFI channel_0 from XAUI channel_0 SFI channel_1 from XAUI channel_1
1Ex0003 =0x11	XAUI channel_0 to/from SFI channel_1 XAUI channel_1 to/from SFI channel_0
1Ex0003 =0x30	XAUI channel_0 from SFI channel_1 XAUI channel_1 to/from SFI channel_1 SFI channel_0 from XAUI channel_0
1Ex0003 =0x31	XAUI channel_0 to/from SFI channel_1 XAUI channel_1 from SFI channel_1 SFI channel_0 from XAUI channel_1

The following illustration shows the cross-connect configurations.

Figure 19 • Cross-Connect Configuration

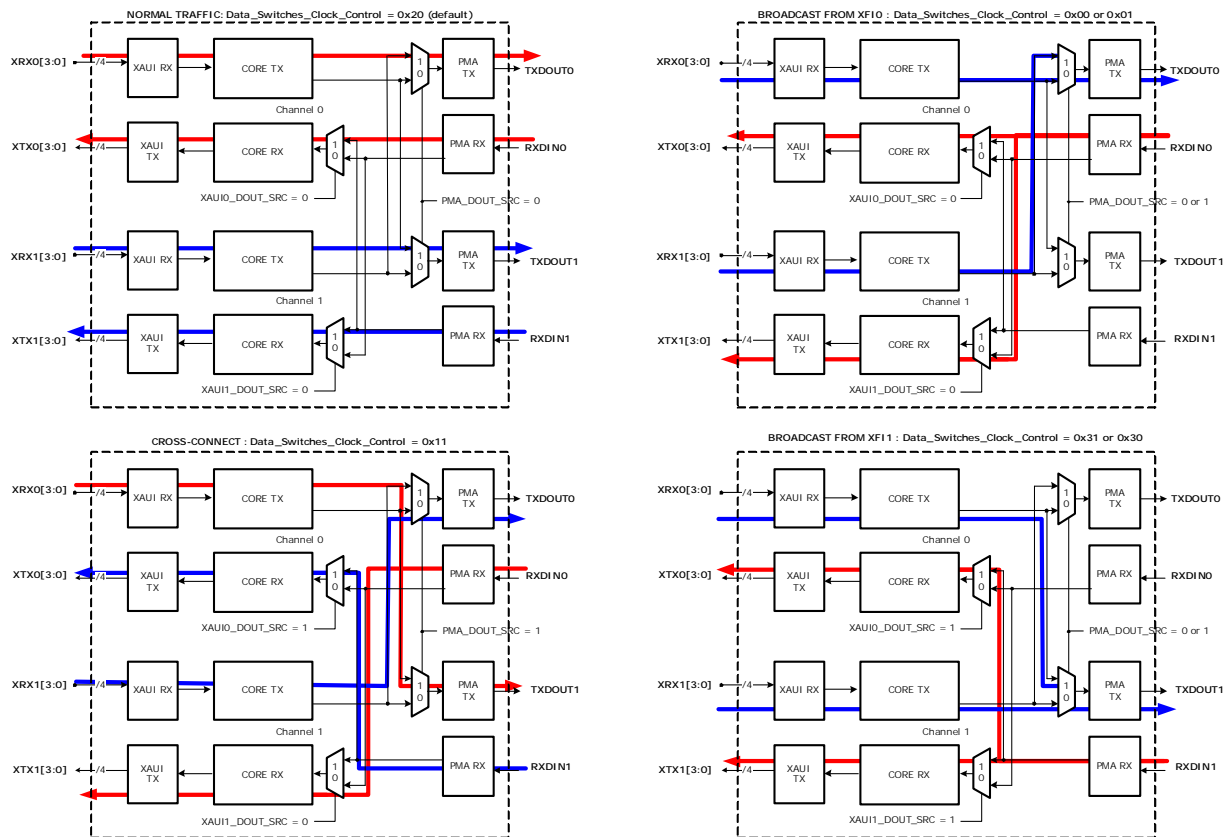

3.9 Host-Side Interface

The XAUI, RXAUI, and 1 GbE host interfaces in the VSC8489-02 device support the following rates:

- XAUI: 4 × 3.125 Gbps
- RXAUI: 2 × 6.25 Gbps
- 1 GbE: 1 × 1.25 Gbps

In RXAUI mode, the two RXAUI lanes are XAUI lane 0 and lane 2. XAUI lane 0 is the RXAUI lane 0 and XAUI lane 2 is RXAUI lane 1. The LSB are sent on lane 0, while MSB are sent on lane 1. In 1 GbE mode, the 1 GbE lanes may be either XAUI lane 0 or lane 3. The following illustration shows the host-side I/O interface.

The XAUI lane order could be swapped through register 4xF002, where bit 2 is to map lane 0 on 3, lane 1 on 2, lane 2 on 1, and lane 3 on 0 of the XAUI output. Bit 0 of same register is to map lane 0 on 3, lane 1 on 2, lane 2 on 1, and lane 3 on 0 of the XAUI input. Furthermore, bit 2 of 4xF002 could be used to invert the polarity of the differential pairs of all four XAUI outputs, and bit 1 of 4xF002 could be used to invert the polarity of the differential pairs of all four XAUI inputs. There is an API function call to assist with setting the lane swap and polarity inversion.

Note: Use AC-coupling for the receive and transmit sides of the host-side interface. For optional DC-coupling, contact your Microsemi representative.

Figure 20 • Host-Side I/O Interface

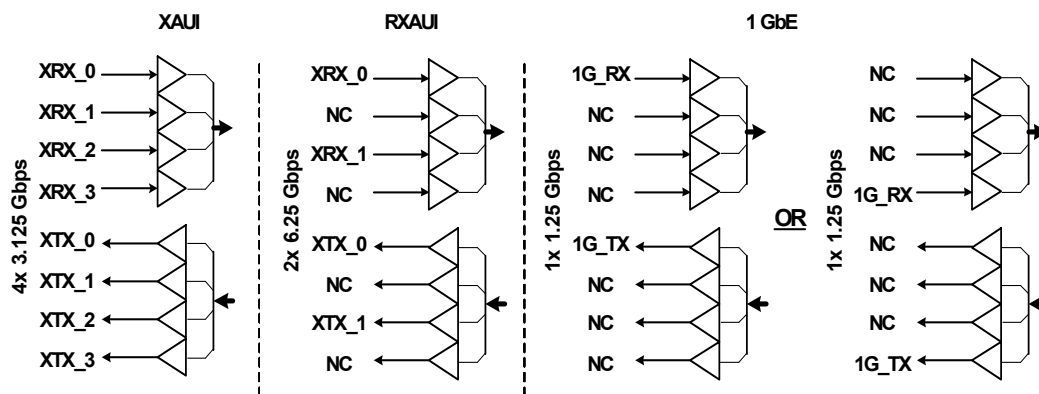

3.9.1 RXAUI Interoperability

The RXAUI implementation is fully interoperable with the Dune network mode 1 and mode 2 RXAUI specification, as summarized in the following table.

Table 21 • RXAUI Interoperability

Mode1	Mode2
De-interleaving uses XAUI A column (align column).	
Transmitter: No internal logic modification. Two 10b characters are presented to one physical lane at a time.	Transmitter: Replaces some K code groups with other code groups to allow receiver to perform de-interleaving (comma replacement).
Receiver: Separates two characters in double rate lane into two physical standard rate lanes. Lane byte ordering block ensures first A character mapped to first logical lane and A column aligned for the deskew block.	
Obeys 6.25 Gbps disparity rules.	Obeys 6.25 Gbps disparity rules.

A host-side SerDes macro (SD6G) is used by each XAUI lane. The SerDes macros are automatically configured to send/receive the proper data rate when the host interface changes between the XAUI/RXAUI/1 GbE modes. The appropriate lanes are also powered down when not in use. For example, XAUI lanes 1 and 3 are powered down when the RXAUI interface is in use.

3.10 Clocking

The following sections describe the clocking functionality of the VSC8489-02 device.

3.10.1 PLL

The VSC8489-02 device includes two PLLs, one on the line-side and another on the host-side. The line-side PLL uses either XREFCK or WREFCK as its reference clock. The host-side PLL uses XREFCK. The following table shows the supported reference clock frequencies.

Table 22 • Supported Reference Clock Frequencies

Clock	Applications	Frequencies
XREFCK	Mainly LAN mode	125 MHz and 156.25 MHz
WREFCK	LAN or WAN mode Synchronous Ethernet	155.52 MHz and 161.13 MHz

Table 22 • Supported Reference Clock Frequencies (continued)

Clock	Applications	Frequencies
SREFCK	Synchronous Ethernet	125 MHz, 155.52 MHz, and 156.25 MHz

3.10.2 Reference Clock

The VSC8489-02 device uses three differential input CML level reference clocks: XREFCK, WREFCK, and SREFCK. The XREFCK is required all the time and may be either 156.25 MHz or 125 MHz.

The VSC8489-02 device features an internal frequency synthesizer that enables operation in 10G LAN/10G WAN/1G LAN modes using a single reference clock input (XREFCK). The host-side PLL is always driven by XREFCK. It is recommended to have the line-side PLL be driven by XREFCK.

For backward compatibility with previous generation PHY chips, WREFCK may be used to drive the line-side PLL. For Synchronous Ethernet applications with non-hitless XREFCK, SREFCK could be used to drive the line-side PLL.

The XREFCK frequency has to be decided before power up, and is selected using the MODE1 and MODE0 pins. The following table shows the MODE pin settings for the various XREFCK frequencies.

Table 23 • XREFCK Frequency Selection

MODE1 Pin	MODE0 Pin	XREFCK Frequency
0	0	156.25 MHz (default)
0	1	Reserved
1	0	125 MHz
1	1	Reserved

The following table shows the supported clock rates and modes.

Table 24 • Supported Clock Rates and Modes

Mode	XREFCK	WREFCK	SREFCK	Tx CMU REF	Rx CMU REF
10.3125G LAN single ref	156.25 MHz			XREFCK	XREFCK
9.95328G WAN single ref	156.25 MHz			XREFCK	XREFCK
1.25G LAN single ref	156.25 MHz			XREFCK	XREFCK
10.3125G LAN single ref	125 MHz			XREFCK	XREFCK
9.95328G WAN single ref	125 MHz			XREFCK	XREFCK
1.25G LAN single ref	125 MHz			XREFCK	XREFCK
10.3125G Sync-E LAN single ref (Hitless)	156.25 MHz			XREFCK	XREFCK
10.3125G Sync-E LAN dual ref	156.25 MHz		161.13 MHz	SREFCK	XREFCK
	156.25 MHz		156.25 MHz	SREFCK	XREFCK
	156.25 MHz		125 MHz	SREFCK	XREFCK
9.95328G Sync-E WAN single ref (Hitless)	156.25 MHz			XREFCK	XREFCK
9.95328G Sync-E WAN dual ref	156.25 MHz		155.52 MHz	SREFCK	XREFCK
9.95328G Sync-E WAN dual ref	156.25 MHz	155.52 MHz		WREFCK	WREFCK
1.25G Sync-E LAN single ref (Hitless)	156.25 MHz			XREFCK	XREFCK

Table 24 • Supported Clock Rates and Modes (continued)

Mode	XREFCK	WREFCK	SREFCK	Tx CMU REF	Rx CMU REF
1.25G Sync-E LAN dual ref	156.25 MHz		125 MHz	SREFCK	XREFCK

3.10.3 Synchronous Ethernet Support

The VSC8489-02 device supports several synchronous Ethernet configurations for 1G and 10G modes of operation. In synchronous Ethernet applications, only one master at a time may be selected from one of the internal line-side Rx or the SREFCK.

- **Single device, internal master:** in this configuration, the line-side Rx captures the serial data input and generates a lane-synchronization signal that contains information about the incoming data rates. The signal is then distributed to all ports of the line-side Tx to form a source-synchronous operation.
- **Single clock LAN, external master:** in this configuration, the XREFCK is gradually changed to the externally generated synchronous Ethernet clock using an external clock distribution chip. The change has to be hitless to avoid data corruption. The XREFCK source may come from one of the port recovered clocks through the RXCKOUT pin.
- **Dual clock LAN, external master:** in this configuration, the XREFCK remains connected to the stable 156.25 MHz system clock or crystal. All the line-side transmits are then synchronized to SREFCK. The F to delta F block accepts the SREFCK clock from external synchronous Ethernet master and generates the lane Sync signal to effectively synchronize all the line-side Tx to this external clock. SREFCK must be 156.25 MHz.
- **Dual clock WAN, external master:** in this configuration, the XREFCK remains connected to the stable 156.25 MHz system clock or crystal. The XREFCK is configured to drive the host-side PLL, while the WREFCK is configured to drive the line-side PLL. The synchronous Ethernet clock is then routed through the SREFCK clock to synchronize all the line-side transmits. SREFCK must be 155.52 MHz.

3.11 Operating Modes

The VSC8489-02 device has three main operation modes: LAN, WAN, and 1 GbE.

3.11.1 10G LAN

In 10G LAN mode, the host interface is XAUI (4 × 3.125 Gbps) or RXAUI (2 × 6.250 Gbps), and the line interface is LAN SFP+ (10.3125 Gbps). A single reference clock input pin, XREFCK, is used by both the line-and host-side interfaces to transmit appropriate rates. For more information about supported reference clock frequencies, [Table 24](#), page 45.

Figure 21 • 10G LAN

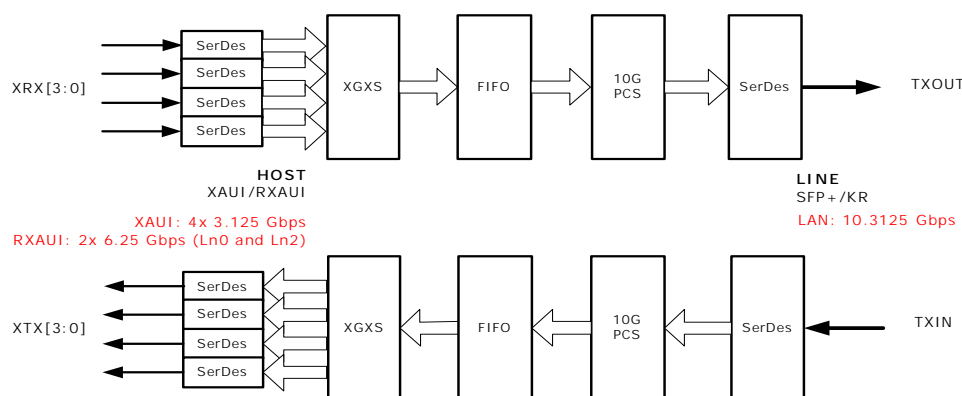

3.11.2 10G WAN

In 10G WAN mode, the host interface is XAUI (4 × 3.125 Gbps) or RXAUI (2 × 6.250 Gbps), and the line interface is SONET/SDH STS-192c (9.95328 Gbps). A single reference clock input pin, XREFCK, is

used by both the line-and host-side interfaces to transmit appropriate rates. For more information about supported reference clock frequencies, see Table 24, page 45. Optionally, WREFCK may be used as the 155.52 MHz reference clock for the line interface. A 622 MHz WREFCK reference frequency is not supported.

Figure 22 • 10G WAN

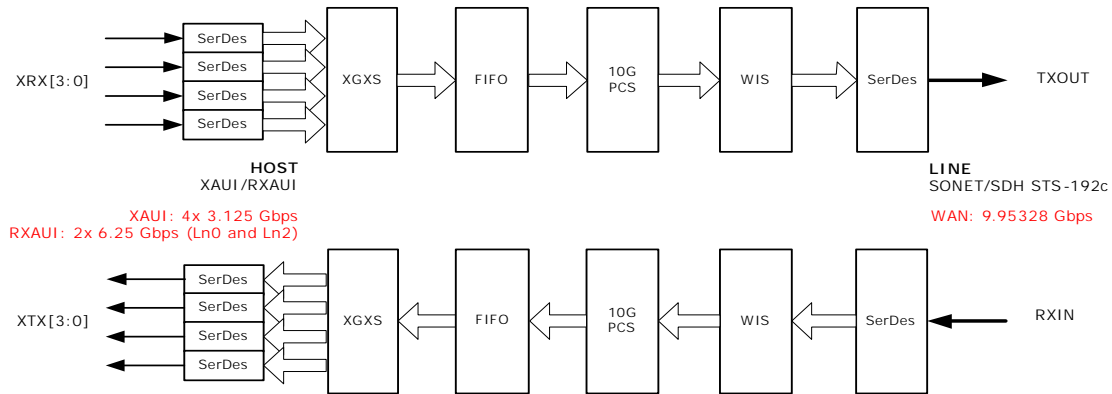

3.11.3 1 GbE

In 1 GbE mode, one XAUI lane on the host interface services the 1 GbE signal (1.25 Gbps). A single reference clock input pin, XREFCK, is used by both the line-and host-side interfaces to transmit appropriate rates. For more information about supported reference clock frequencies, see Table 24, page 45. MACs should be enabled to meet the pause turn around time spec, as defined in the IEEE specifications.

Figure 23 • 1 GbE

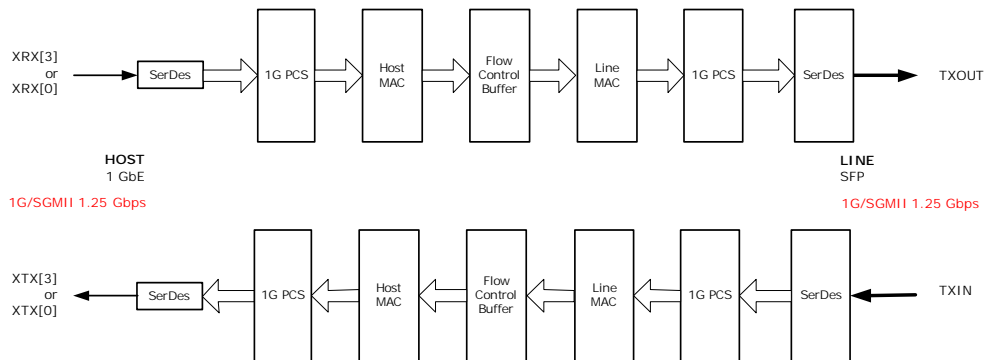

3.12 Management Interfaces

This section contains information about the low-speed serial interfaces of the VSC8489-02 device. The primary control and monitor interfaces in the design are as follows:

- MDIO
- SPI slave
- Two-wire serial (slave)
- Two-wire serial (master)
- GPIO
- JTAG

The VSC8489-02 device supports three different interfaces for accessing status and configuration registers: MDIO, SPI slave, and two-wire serial slave. Only one of the interfaces can be active at a time. The VSC8489-02 device doesn't arbitrate between these interfaces.

Note: Users must exercise caution, and ensure that multiple interfaces are not active at the same time.

3.12.1 MDIO Interface

The MDIO interface in the VSC8489-02 device complies with IEEE 802.3ae Clause 45. For more information, see the IEEE standard. The MDIO management interface consists of a bi-directional data path (MDIO) and a clock reference (MDC).

MDIO instructions can be used to read registers, write registers, and perform post-read-increment-address instructions. Due to its slow bandwidth and high latency, the MDIO interface is not recommended as the only interface to access the VSC8489-02 device.

Note: The maximum data rate of the MDIO interface is 2.5 Mbps.

The PADDR[4:1] pins select the MDIO port addresses to which the VSC8489-02 device will respond. A single VSC8489-02 device requires the use of two MDIO port addresses, one for each channel. The port address transmitted in MDIO read/write commands to access registers in a particular VSC8489-02 channel is shown in the following table. The port address is a function of the PADDR pins and a pre-programmed number indicating the channel number. Up to sixteen VSC8489-02 devices can be controlled by a single MDIO host.

Table 25 • MDIO Port Addresses Per Channel

Channel Number	Channel's Port Address
1	{PADDR[4:1], 1}
0	{PADDR[4:1], 0}

3.12.1.1 Accessing 32-Bit Data Registers

Even though the MDIO interface is defined to access 16-bit data registers, 32-bit configuration and status registers are present in the line and host MACs in 1G mode and line-side SerDes. Use the following steps when accessing registers in 32-bit blocks.

3.12.1.1.1 Write to 32-Bit Register

1. Issue address instruction specifying the MDIO address for bits [31:16].
2. Issue write instruction to write data to register bits [31:16].
3. Issue address instruction specifying the MDIO address for bits [15:0].
4. Issue write instruction to write data to register bits [15:0].

Note: Writing to the two halves of the 32-bit register in the opposite order is not permitted. Nor is it possible to write to only one-half of the register. All four MDIO instructions must be issued to write to a 32-bit register.

3.12.1.1.2 Read 32-Bit Register

1. Issue address instruction specifying the MDIO address for bits [15:0].
2. Issue read-increment instruction. The data read is the contents of register bits [15:0].
3. Issue read instruction. The data read is the contents of register bits [31:16].

Note: Perform all three steps to read a 32-bit register even when reading consecutive addresses. Issuing back-to-back read-increment instructions to read consecutive 32-bit register addresses is not supported.

Register addresses listed for the line and host MACs in 1G mode and line-side SerDes apply to the SPI slave and two-wire serial slave interfaces, which support direct access to 32-bit data registers. There are two MDIO addresses for each of these 32-bit data registers: one address to access data bits [31:16] and one address to access data bits [15:0]. Contact Microsemi for support using the MDIO interface to access line and host MACs in 1G mode and line-side SerDes registers.

3.12.1.2 MDIO Device and Register Addresses

The VSC8489-02 device registers are arranged according to the MDIO devices as defined in IEEE 802.3 clause 45, as shown in the following list:

- Device 1: PMA and line-side interface registers
- Device 2: WIS registers
- Device 3: 10G PCS, 1G PCS, FC buffers
- Device 4: XGXS PCS and host-side interface registers
- Device 1E: Global, SFP+, and PLLs

3.12.2 SPI Slave Interface

The VSC8489-02 device supports the serial parallel interface (SPI) for reading and writing registers for high bandwidth tasks. The SPI interface is also capable of accessing all status and configuration registers. The SPI slave port consists of a clock input (SCK), data input (MOSI), data output (MISO), and slave select input (SSN).

Note: The SPI slave interface is the recommended interface to access status and configuration registers for the rest of the device.

Drive the SSN pin low to enable the interface. The interface is disabled when SSN is high and MISO is placed into a high impedance state. The VSC8489-02 device captures the state of the MOSI pin on the rising edge of SCK. 56 data bits are captured on the MOSI pin and transmitted on the MISO pin for each SPI instruction. The serial data bits consist of 1 read/write command bit, 23 address bits and 32 register data bits.

The 23-bit addressing scheme consists of a 2-bit channel number, a 5-bit MDIO device number, and a 16-bit register number. For example, the 23-bit register address for accessing the GPIO_0_Config_Status register in channel 1 (device number is 0x1E and register number is 0x0100) is 0x3E0100. The notion of device number conforms to MDIO register groupings. For example, device 2 is assigned to WIS registers.

The following table shows the order in which the bits are transferred on the interface. Bit 55 is transferred first, and bit 0 is transferred last. This sequence applies to both the MOSI and MISO pins.

Table 26 • SPI Slave Instruction Bit Sequence

Bit	Name	Description
55	Read/Write	0: Read 1: Write
54:53	Port/Channel Number	00: Port/Channel 0 01: Port/Channel 1 10, 11: Reserved
52:48	Device Number	5 bit device number Bit 4 corresponds to SPI instruction bit 52 Bit 0 corresponds to SPI instruction bit 48
47:32	Register Number	16 bit register number Bit 15 corresponds to SPI instruction bit 47 Bit 0 corresponds to SPI instruction bit 32
31:0	Data	32 bit data Bit 31 corresponds to SPI instruction bit 31 Bit 0 corresponds to SPI instruction bit 0

The register data received on the MOSI pin during a write operation is the data value to be written to a VSC8489-02 register. Register data received on the MOSI pin during a read operation is not used, but must still be delivered to the device.

The VSC8489-02 device SPI slave has a pipelined read process. Two read instructions must be sent to read a single register. The first read instruction identifies the register address to be read. The MISO data transmitted on the second read instruction contains the register contents from the address specified in the first instruction. While a pipelined read implementation is not the most efficient use of bandwidth to read a single register, it is very efficient when performing multiple back-to-back reads. The second read instruction contains the address for the second register to be read, plus the data read from the first register. The third read instruction contains the address for the third register to be read, plus the data read from the second register. Register reads can continue in this fashion indefinitely. The following illustrations show the situations where back-to-back read instructions are issued.

Figure 24 • SPI Single Register Read

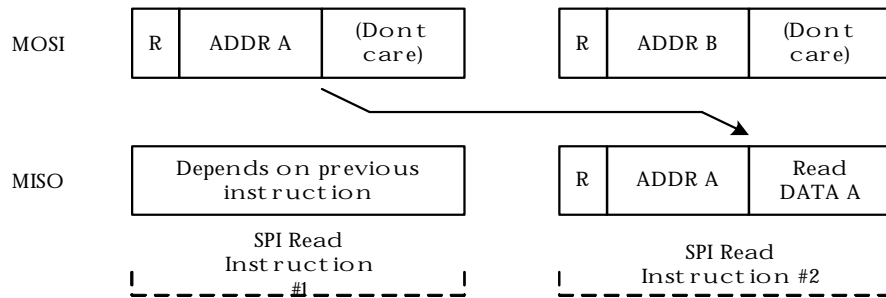
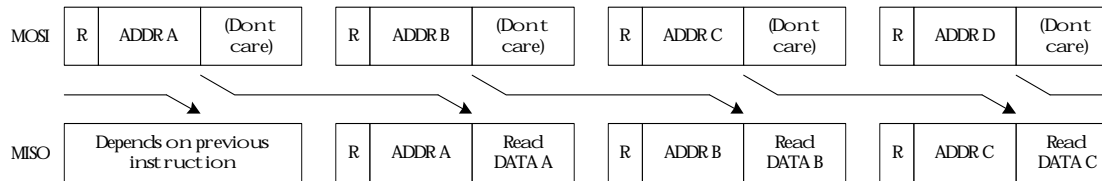
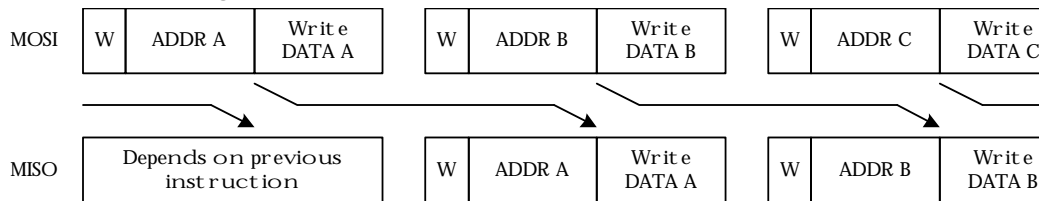

Figure 25 • SPI Multiple Register Reads



The SPI read instruction illustrations also point out the read/write state and address bits on the MISO output match the information received in the previous instruction. The SPI master could use this data to verify the device captured the previous instruction properly, or simply ignore the data. The following illustration shows the MISO output during write instructions reporting the previous instruction's read/write state, address, and register write data.

Figure 26 • SPI Multiple Register Writes



The following illustration shows that when a read instruction follows a write instruction, the MISO data during the read instruction is the data field from the previous write.

Figure 27 • SPI Read Following Write

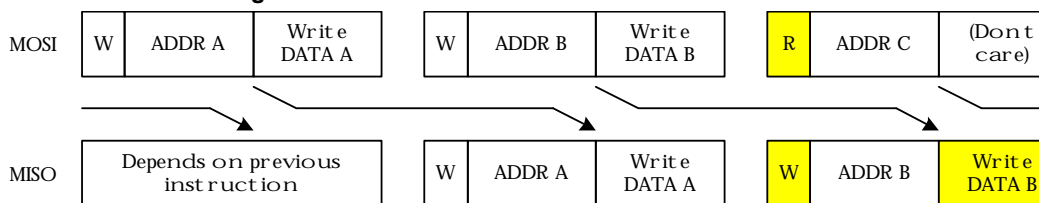

The following illustration shows that when a write instruction follows a read instruction, the MISO data during the write instruction is not pipelined read data. MISO contains all 0's in the data field.

Figure 28 • SPI Write Following Read

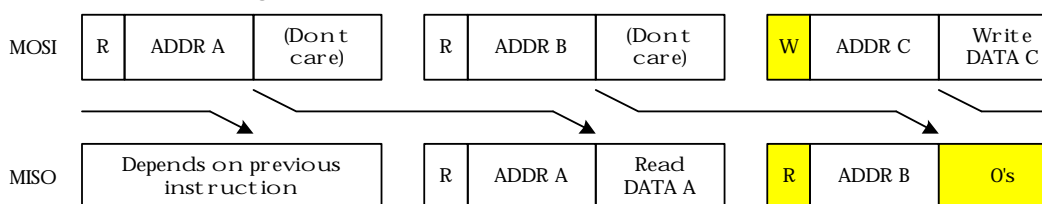

Some VSC8489-02 registers are made up of less than 32 data bits. Any bits not defined for a register will return a 0 when the register is read. Reading an invalid register address will return 0x0.

There is one hazard condition to be aware of when issuing two read instructions to read a single clear-on-read register. Issuing two read instructions internally fetches data twice, even though valid read data is present only in the second instruction. Fetching data also resets a clear-on-read register. The address specified in the second read instruction should be something other than the clear-on-read register address. This prevents an event causing register re-assertion occurring between the two read instructions from being cleared and never detected. The address in the second instruction can be any register not having a clear-on-read function. Device_ID is one example. The same address can be used in each read instruction when continuously polling a clear-on-read register. This works because subsequently fetched data is transmitted from the interface, allowing assertion between reads to be detected. Only the last read instruction where fetched data is not transmitted, should some other address in the instruction be used.

3.12.2.1 MISO Output Timing Modes

MISO changes state when SCK transitions from high to low in the default SPI operating mode. This aids in meeting hold time at the SPI master, assuming the master captures the data on the rising SCK edge. The SPI port can run up to a maximum of 30 Mbps, depending upon the VSC8489-02 device SCK-to-MISO timing, SCK duty cycle, the board layout, and the external SPI master's interface timing requirements. For more information about SPI timing, see [Table 51](#), page 71.

The SPI slave port has an alternate operating mode that allows the interface to run faster. Setting register bit SPI_CTRL.FAST_MODE=1 configures the SPI slave such that MISO changes state when SCK transitions from low to high. Thus, data is both transmitted from the SPI slave and captured by the SPI master on a rising SCK edge. The interface can run faster in this mode by using the entire SCK clock period instead of half the period to transfer data from the slave to the master. Care must be taken to ensure the SPI master's hold time requirement is met. The maximum data transfer rate for the SPI slave in this mode is 30 Mbps. The following illustrations show MISO timing in the default and slave modes.

Figure 29 • SPI Slave Default Mode

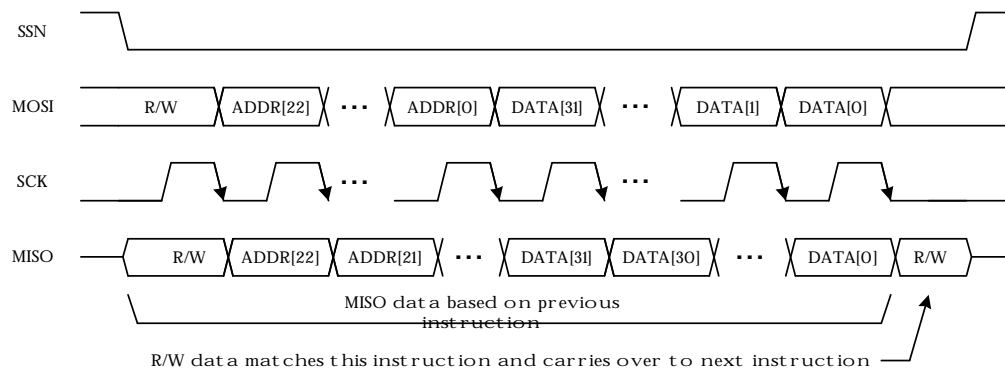
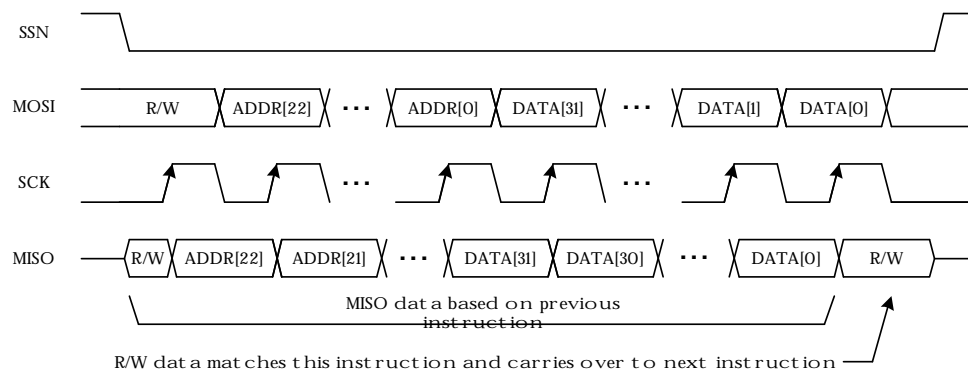

Figure 30 • SPI Slave Fast Mode



MISO output timing is the only difference between the two SPI modes. Sampling of MOSI on the rising SCK clock edge remains the same, so writing to the VSC8489-02 device registers is identical in both

modes. Thus, the SPI_CTRL.FAST_MODE register setting may be modified using the SPI slave port to change the port's MISO output timing.

3.12.3 Two-Wire Serial (Slave) Interface

The VSC8489-02 device registers may be read and written using a two-wire serial slave interface. The two-wire serial slave SCL and SDA pins are multifunction general purpose I/O (GPIO) pins, GPIO_3 and GPIO_2, respectively. The GPIO pins are configured to serve SCL and SDA functions following device reset.

The slave address assigned to the VSC8489-02 device is a function of four fixed values and the MDIO port address pins. The 7-bit slave address is {1000, PADDR4, PADDR3, PADDR2}. The use of the port address pins allows multiple VSC8489-02 devices to be serviced by a single two-wire serial (master). The maximum data transfer rate for the interface is 400 kbps.

Note: The two-wire serial slave interface does not work with two-wire serial masters using 10-bit slave addresses.

A valid START condition is generated by a two-wire serial master device by transitioning the SDA line from high to low while the SCL line is high. Data is then transferred on the SDA line, most significant bit (MSB) first, with the SCL line clocking data. Data transitions during SCL low periods are valid (read) or latched (write) when SCL pulses high then low. Data transfers are acknowledged (ACK) by the receiving device for data writes and by the master for data reads. An acknowledge is signaled by holding the SDA signal low while pulsing SCL high then low. The master terminates data transfer by generating a STOP condition by transitioning SDA low to high while SCL is high.

Note: If the external two-wire serial master device gets out of sync with the two-wire serial slave interface, the master device must issue a bus reset sequence. This puts the two-wire serial slave interface back into a state that allows it to receive future two-wire serial instructions. The external two-wire serial master device and the two-wire serial slave interface can become out-of-sync and freeze the bus if either device is reset during an instruction.

The following illustration shows a two-wire serial bus reset sequence. The reset sequence consists of a START symbol, nine SCK clock pulses while SDA is high, another START symbol, and a STOP symbol.

Figure 31 • Two-Wire Serial Bus Reset Sequence

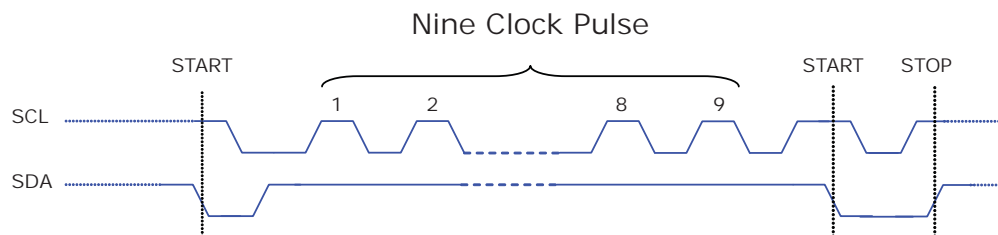

Registers in the VSC8489-02 device are accessed using the 24-bit addressing scheme. The first 8 bits consist of one logic LOW, the channel number (00, 01, 10, 11), and the 5-bit MDIO device number of the register to be accessed. The next 16 bits are the register number. For example, the 24-bit register address for accessing the GPIO_0_Config_Status register in channel 1 (device number 0x1E and register number 0x0100) is 0x3E0100. The notion of device number conforms to MDIO register groupings. For example, device 2 is assigned to WIS registers. The following illustration shows the 24-bit addressing scheme used to access registers.

Figure 32 • Two-Wire Serial Slave Register Address Format

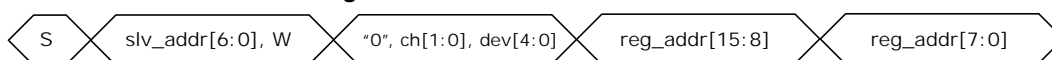

An illegal two-wire serial slave read instruction to an invalid channel number, device number, or register address will return a read value of 0x0000 when the slave address matches this device.

Four bytes of data are transferred on the two-wire serial bus after the address when a register is read or written. Data register bits [31:24] are transferred first, followed by bits [23:16], bits [15:8] and finally bits [7:0]. An ACK symbol is sent between each byte of data. Any bits not defined in a register will return a 0 when the register is read.

The following illustration shows the data transferred on the SDA pin during a register write operation. The R/W bit following the slave address is set to logic low to specify a write operation.

Figure 33 • Two-Wire Serial Write Instruction

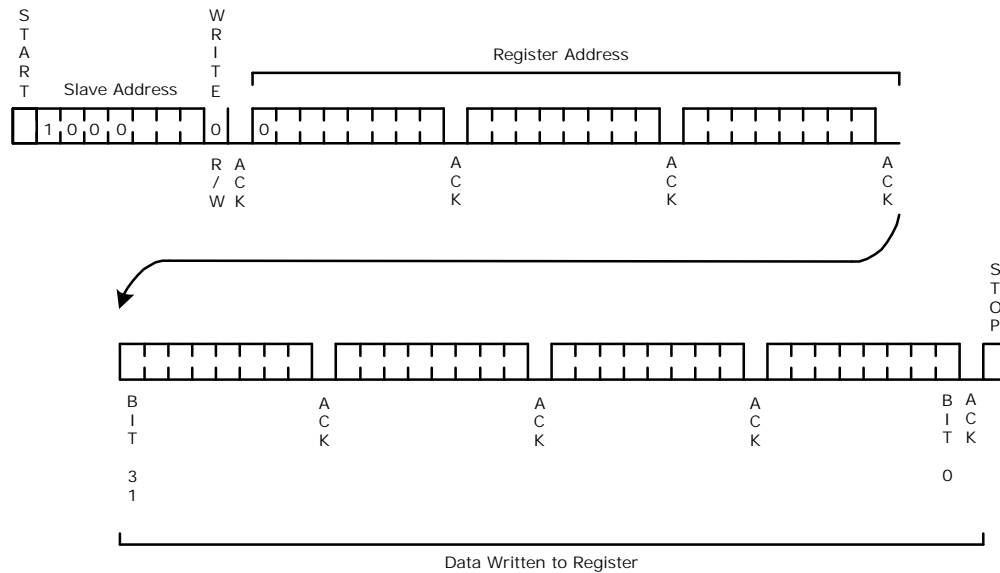

The register address to be accessed is specified by initiating a write operation. After the slave address and three register address bytes are sent to the VSC8489-02 device, a START condition must be re-sent, followed by the slave address with the read/write bit set to logic high. The four-byte data register contents are then transmitted from the VSC8489-02 device. The two-wire serial (master) sends NO ACK after the fourth data byte to indicate it has finished reading data. The following illustration shows data transferred on the SDA pin during a register read operation.

Figure 34 • Two-Wire Serial Read Instruction

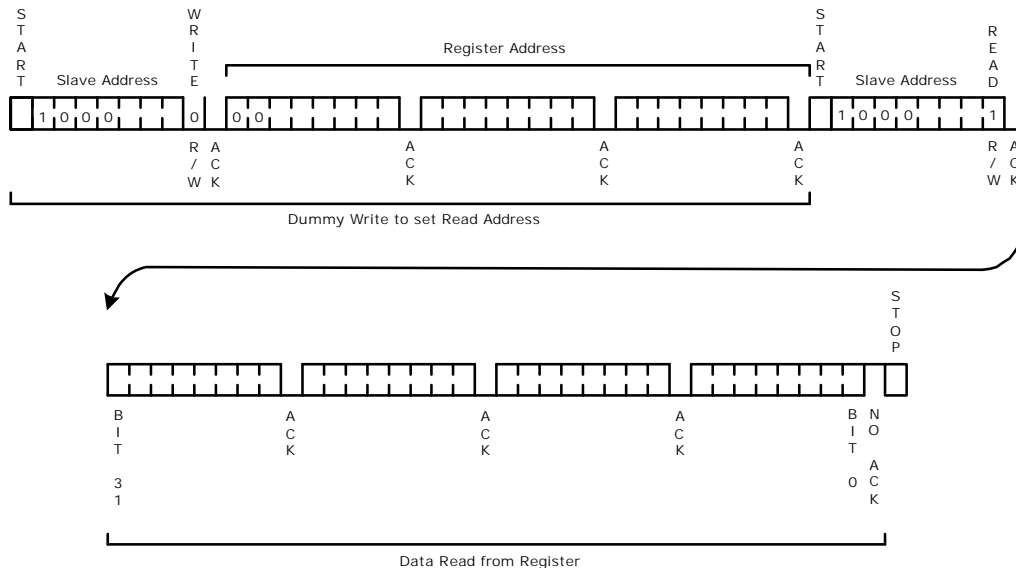

The two-wire serial slave interface supports sequential read and sequential write instructions.

3.12.4 Two-Wire Serial (Master) Interface

A two-wire serial master interface in the VSC8489-02 channel is available for SFP+/XFP module management. A two-wire serial master interface per channel is required, because the slave address in the optics modules are identical. Two-wire serial interface instructions used to access optics module registers are initiated by writing to VSC8489-02 registers. The two-wire serial interface busses are brought out through GPIO pins. Channel 0's two-wire serial interface is enabled by configuring GPIO_6 to function as SDA and GPIO_7 to function as SCL. Channel 1's two-wire serial interface is enabled by configuring GPIO_10 to function as SDA and GPIO_11 to function as SCL.

The two-wire serial master interface must be configured before initiating any instructions. The slave ID to be transmitted in the first byte of every instruction is selectable in the SLAVE_ID register. The default setting is 0x50. The interface's data rate is determined by the PRESCALE register. The default data rate is 400 kbps.

The two-wire serial master transmits instructions for slave devices with 8-bit data registers and 256 register addresses per slave ID. Always read register I2C_BUS_STATUS.I2C_BUS_BUSY or I2C_READ_STATUS_DATA.I2C_BUS_BUSY to verify the previous instruction has finished prior to initiating a new instruction. Instructions initiated when the interface is busy will be ignored. Both registers report the same interface busy status. The same busy status is reported in two registers for user convenience.

The two-wire serial master initiates a write instruction when the I2C_WRITE_CTRL register is written. The value written to I2C_WRITE_CTRL.WRITE_ADDR is the register address to be modified in the slave device. The value written to I2C_WRITE_CTRL.WRITE_DATA is the data to be written to the slave device's register. The I2C_BUS_STATUS register reports the status of the write instruction. I2C_BUS_STATUS.I2C_BUS_BUSY indicates when the instruction has finished. I2C_BUS_STATUS.I2C_WRITE_ACK=1 means the two-wire serial master received ACKs from the slave at appropriate times. I2C_BUS_STATUS.I2C_WRITE_ACK is cleared each time a new instruction is issued. If the two-wire serial master did not receive ACKs from the slave at appropriate times (I2C_BUS_STATUS.I2C_WRITE_ACK=0), the interface is likely stuck in a state waiting for the ACK. Writing a 1 to the BLOCK_LEVEL_RESET1.I2CM_RESET register will reset the two-wire serial master and release it from its stuck state. The slave device should then be put into a known state by writing any value to the I2C_RESET_SEQ register. The two-wire serial master issues a bus reset sequence when this register is written. For more information, see [Two-Wire Serial \(Slave\) Interface](#), page 52.

The two-wire serial master initiates a read instruction when the I2C_READ_ADDR register is written. The value written to I2C_READ_ADDR.READ_ADDR is the register address to be accessed in the slave device. I2C_READ_STATUS_DATA.READ_DATA contains the data read from the slave device. READ_DATA is not valid until I2C_READ_STATUS_DATA.I2C_BUS_BUSY=0 to indicate the instruction completed. The two-wire serial master does not support read-increment instructions.

3.12.5 GPIO

General purpose input/output (GPIO) pins in the VSC8489-02 device serve multiple functions. The GPIO pins are bidirectional where the driver portion is an open-drain buffer. The following table shows the functions that each pin supports and the registers used to configure the pin functions. Leave GPIO pins unconnected when not in use. When configured as output, they are open-drained and a pull-up is required.

Table 27 • GPIO Functions

Pin	Configuration Registers	Functions
GPIO_0	GPIO_0_Config_Status GPIO_0_Config2	Traditional I/O (default) Observed internal signals MOD_ABS_Channel_0 PMTICK ROSI frame pulse 0 Tx Activity LED WIS_INTB Leave unconnected when not used

Table 27 • GPIO Functions (continued)

Pin	Configuration Registers	Functions
GPIO_1	GPIO_1_Config_Status GPIO_1_Config2	Traditional I/O (default) Observed internal signals ROSI_CLK_0 Rx Activity LED WIS_INTA Leave unconnected when not used
GPIO_2	GPIO_2_Config_Status GPIO_2_Config2	Traditional I/O Observed internal signals Slave two-wire serial - SDA (default) ROSI_DATA_0 Tx Activity LED WIS_INTB
GPIO_3	GPIO_3_Config_Status GPIO_3_Config2	Traditional I/O Observed internal signals Slave two-wire serial - SCL (default) TOSI_FRAME_PULSE_0 Rx Activity LED WIS_INTB
GPIO_4	GPIO_4_Config_Status GPIO_4_Config2	Traditional I/O (default) Observed internal signals TOSI_CLK_0 Tx Activity LED WIS_INTB
GPIO_5	GPIO_5_Config_Status GPIO_5_Config2	Traditional I/O (default) Observed internal signals TOSI_INPUT_0 Rx Activity LED WIS_INTA Leave unconnected when not used
GPIO_6	GPIO_6_Config_Status GPIO_6_Config2	Traditional I/O (default) Observed internal signals Ch0 SFP I2C SDA ROSI_FRAME_PULSE_1 Tx Activity LED WIS_INTB
GPIO_7	GPIO_7_Config_Status GPIO_7_Config2	Traditional I/O (default) Observed internal signals Ch0 SFP I2C SCL ROSI_CLK_1 Rx Activity LED WIS_INTA
GPIO_8	GPIO_8_Config_Status GPIO_8_Config2	Traditional I/O (default) Observed internal signals MOD_ABS_Channel_0 PMTICK ROSI_DATA_1 Tx Activity LED WIS_INTA

Table 27 • GPIO Functions (continued)

Pin	Configuration Registers	Functions
GPIO_9	GPIO_9_Config_Status GPIO_9_Config2	Traditional I/O (default) Observed internal signals Mod_ABS channel 1 PMTICK TOSI_FRAME_PULSE_1 Rx Activity LED WIS_INTA
GPIO_10	GPIO_10_Config_Status GPIO_10_Config2	Traditional I/O (default) Observed internal signals Ch1 SFP I2C SDA TOSI_CLK_1 Tx Activity LED WIS_INSTB
GPIO_11	GPIO_11_Config_Status GPIO_11_Config2	Traditional I/O (default) Observed internal signals Ch1 SFP I2C SCL TOSI_INPUT_1 Rx Activity LED WIS_INTA
GPIO_12	GPIO_12_Config_Status GPIO_12_Config2	Traditional I/O (default) Observed internal signals Tx Activity LED WIS_INTA
GPIO_13	GPIO_13_Config_Status GPIO_13_Config2	Traditional I/O (default) Observed internal signals Rx Activity LED WIS_INTA
GPIO_14	GPIO_14_Config_Status GPIO_14_Config2	Traditional I/O (default) Observed internal signals Tx Activity LED WIS_INTA
GPIO_15	GPIO_15_Config_Status GPIO_15_Config2	Traditional I/O (default) Observed internal signals Rx Activity LED WIS_INTA

When a GPIO pin is programmed to be a traditional I/O, the pin may be driven high or low. It may also serve as an input and an LED driver capable of blinking at various rates. An interrupt pending register may optionally be asserted when the pin is in input mode and the pin changes state. All of these functions are configured using the pin configuration register settings shown in the preceding table.

The GPIO pin's output driver is automatically enabled when the pin function is set to observe internal signals. The second configuration register listed for each pin selects which internal signal is transmitted from the pin.

3.12.6 JTAG

The VSC8489-02 device has a IEEE 1149.1–2001 compliant JTAG interface. The following table shows the supported instructions and corresponding instruction register codes. The code's least significant bit is

shifted into TDI first when loading an instruction (the 0 is shifted in first when loading the IDCODE instruction).

Table 28 • JTAG Instructions and Register Codes

Instruction	Register Code	Notes
IDCODE	11111111111111111111111111111110	
BYPASS	11111111111111111111111111111111	
EXTEST	1111111111111111111111111111101000	
EXTEST_PULSE	111111101111111111111111101000	
EXTEST_TRAIN	111111011111111111111111101000	
SAMPLE	11111111111111111111111111111000	
PRELOAD	11111111111111111111111111111000	
LV_HIGHZ	1111111111111111111111111001111	Provides the ability to place outputs in a high impedance state to facilitate manufacturing test and PC board diagnostics. The XAUI and SFP+ serial data outputs are not put into the high impedance state when this instruction is loaded in the JTAG TAP controller.
CLAMP	111111111111111111111111101111	Provides the ability to place all outputs in a predefined state when the scan process is being used to test other devices on a PC board.

The RESETN pin must be driven to logic high before shifting data out of the DEVICE ID data register when the IDCODE instruction is loaded in the JTAG TAP controller.

4 Registers

Information about the registers for this product is available in the attached Adobe Acrobat file. To view or print the information, double-click the attachment icon.

5 Electrical Specifications

This section provides the DC characteristics, AC characteristics, recommended operating conditions, and stress ratings for the VSC8489-02 device.

5.1 DC Characteristics

This section contains the DC specifications for the VSC8489-02 device.

5.1.1 DC Inputs and Outputs

The following table lists the DC specifications for the LVTTTL inputs and outputs for the VSC8489-02 device. The LVTTTL inputs are 3.3 V tolerant.

Table 29 • LVTTTL Input and Push/Pull Output DC Characteristics

Parameter	Symbol	Minimum	Maximum	Unit	Condition
Output high voltage, LVTTTL	V_{OH_TTL}	1.8	V_{DDTTL}	V	$V_{DDTTL} = 2.5\text{ V}$ and $I_{OH} = -4\text{ mA}$
Output low voltage, LVTTTL	V_{OL}		0.5	V	$V_{DDTTL}/V_{DDMDIO} = 2.5\text{ V}$ and $I_{OL} = 4\text{ mA}$
Input high voltage	V_{IH}	1.7	V_{DDTTL}	V	$V_{DDTTL}/V_{DDMDIO} = 2.5\text{ V}$
Input low voltage	V_{IL}		0.8	V	$V_{DDTTL}/V_{DDMDIO} = 2.5\text{ V}$
Input high current	I_{IH}		500	μA	$V_{IH} = V_{DDTTL}/V_{DDMDIO}$
Input low current	I_{IL}	-100		μA	$V_{IL} = 0\text{ V}$

Table 30 • LVTTLOD Input and Open-Drain Output DC Characteristics

Parameter	Symbol	Minimum	Maximum	Unit	Condition
Output high voltage, open drain	V_{OH_OD}	See note ¹	V_{DDTTL}	V	$V_{DDTTL}/V_{DDMDIO} = 2.5\text{ V}$ and $I_{OH} = -4\text{ mA}$
Input high leakage current, open drain	I_{OZH}		100	μA	
Output low voltage, open drain	V_{OL}		0.5	V	$V_{DDTTL}/V_{DDMDIO} = 2.5\text{ V}$ and $I_{OL} = 4\text{ mA}$
Input high voltage	V_{IH}	1.7	V_{DDTTL}	V	$V_{DDTTL}/V_{DDMDIO} = 2.5\text{ V}$
Input low voltage	V_{IL}		0.8	V	$V_{DDTTL}/V_{DDMDIO} = 2.5\text{ V}$
Input high current	I_{IH}		500	μA	$V_{IH} = V_{DDTTL}/V_{DDMDIO}$
Input low current	I_{IL}	-100		μA	$V_{IL} = 0\text{ V}$

1. Determined by the loading current of the other devices connecting to this pin, the I_{OZH} current of this pin, and the value of the pull-up resistor used.

5.1.2 Reference Clock

The following table lists the DC specifications for the reference clock for the VSC8489-02 device.

Table 31 • Reference Clock DC Characteristics

Parameter	Symbol	Minimum	Maximum	Unit	Condition
XREFCK/WREFCK differential input swing, low ¹	$\Delta V_{I_DIFF_LOW}$	200	1200	mV _{P-P}	CML reference clock input
XREFCK/WREFCK differential input swing, high ¹	$\Delta V_{I_DIFF_HIGH}$	1100	2400	mV _{P-P}	LVPECL reference clock input
SREFCK differential input swing	ΔV_{I_DIFF}	200	2400	mV _{P-P}	

1. An API call is used to set the input swing to be high or low.

5.2 AC Characteristics

This section contains the AC specifications for the VSC8489-02 device. The specifications apply to all channels. All the XAUI/RXAUI/SFI I/Os should be AC-coupled and work in differential.

5.2.1 Receiver Specifications

The specifications in the following table correspond to line-side 10G receiver input, SFI point D. Point D assumes that the input is from a compliant point C output and a compliant SFI or XFI channel according to the SFP+ standard (SFF-8431) or the XFP multisource agreement (INF-8077i). The measurement is done with a 9 dB channel loss unless stated otherwise. The jitter and amplitude measurements are calibrated at point C, as specified in SFF-8431 revision 4.1.

Table 32 • Line-Side 10G Receiver Input (SFI Point D 9.95328G) AC Characteristics

Parameter	Symbol	Minimum	Typical	Maximum	Unit	Condition
RXIN input data rate, 10 Gbps		9.95328 – 100 ppm	10.3125	10.3125 + 100 ppm	Gbps	10 Gbps LAN/WAN mode
RXIN linear mode differential input data swing	$\Delta VRXIN_{LINEAR}$	180		600	mV	Voltage modulation amplitude (VMA)
RXIN limiting mode differential input data swing	$\Delta VRXIN_{LIMITING}$	300		850	mV	Measured peak-to-peak
RXIN AC common-mode voltage	V_{CM}			15	mV _{RMS}	
Differential return loss	RL_{SDD11}			–12	dB	0.01 GHz to 2.0 GHz
Differential return loss	RL_{SDD11}			–6.68 + 12.1 x log ₁₀ (f/5.5)	dB	2.0 GHz to 11.1 GHz
Reflected differential to common-mode conversion	RL_{SCD11}			–10	dB	0.1 GHz to 11.1 GHz
99% jitter	99% _{JIT_P-P}			0.42	UI	
Pulse width shrinkage jitter	DDPWS _{JIT_P-P}			0.3	UI	
Total jitter tolerance	TOL _{JIT_P-P}			0.70	UI	

Table 32 • Line-Side 10G Receiver Input (SFI Point D 9.95328G) AC Characteristics (continued)

Parameter	Symbol	Minimum	Typical	Maximum	Unit	Condition
Eye mask X1	X1			0.35	UI	
Eye mask Y1	Y1	150			mV	
Eye mask Y2	Y2			425	mV	
Waveform distortion penalty	WDPC			9.3	dBe	BER 1E-12. This parameter of DAC is measured with 7 dB SFI channel loss.
Voltage modulation amplitude	VMA	180			mV	BER 1E-12. This parameter of DAC is measured with 7 dB SFI channel loss.
Optical sensitivity (ROP), back-to-back, 10.3 Gbps	S_{B2B}			-24	dBm	BER 1E-12, PRBS31 and 10 GbE frame, 5.76 dB SFI channel loss.
Optical sensitivity (ROP), with fiber plant, 10.3 Gbps	S_{FIBER}			-21	dBm	95 km single-mode fiber, BER 1E-12, PRBS31 and 10 GbE frame, 5.76 dB SFI channel loss.
Chromatic dispersion penalty	F_{CDP}		1.5	3	dB	1600 ps/nm, 5.76 dB SFI channel loss.
OSNR vs BER with fiber plant, 10.3 Gbps	$OSNR_{FEC}$	16			dB	95 km single-mode fiber, BER 7E-4, 5.76 dB SFI channel loss.

The following illustration shows the sinusoidal jitter tolerance for the SFI datacom.

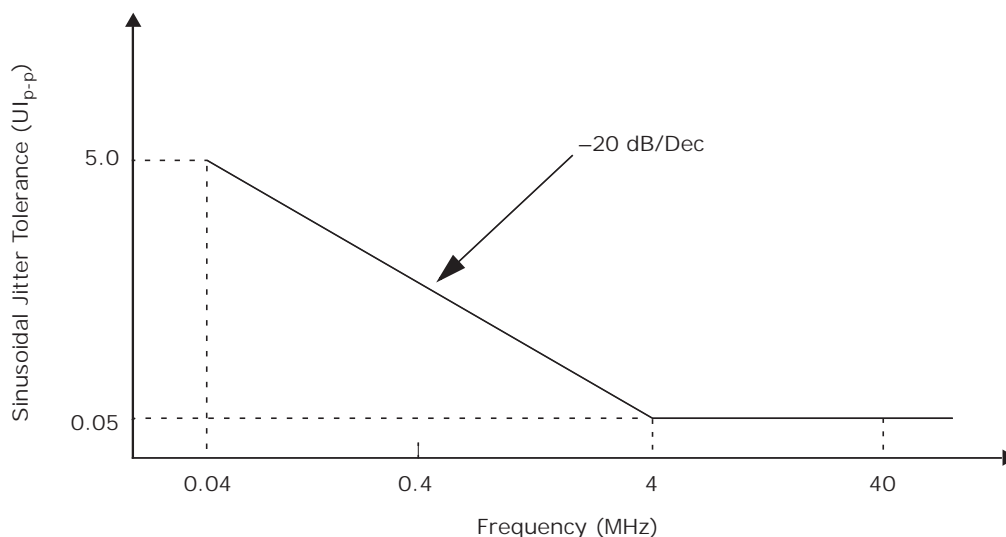
Figure 35 • SFI Datacom Sinusoidal Jitter Tolerance

The following table lists the 10G input jitter specifications for the VSC8489-02 device.

Table 33 • Line-Side SONET 10G Input Jitter AC Characteristics

Parameter	Symbol	Minimum	Typical	Maximum	Unit	Condition
RXIN input data rate, 10 Gbps WAN		9.95328 – 100 ppm	9.95328	9.95328 + 100 ppm	Gbps	
Sinusoidal jitter tolerance, 9.95 Gbps	SJ _T	1.5x jitter mask				GR-253 according to SONET OC-192 standard

The host-side 6.25 Gbps receiver operating in RXAUI mode complies with the AC characteristics specified for CEI-6G-SR interfaces according to OIF-CEI-02.0.

Table 34 • Host-Side RXAUI Receiver AC Characteristics

Parameter	Symbol	Minimum	Maximum	Unit	Condition
Data rate		6.25 – 100 ppm	6.25 + 100 ppm	Gbps	
Differential peak-to-peak input voltage	V _{I_DIFF}	125	750	mV	AC-coupled, measured peak-to-peak each side (both sides driven)
Differential input return loss	RL _{SDD11}		–8	dB	100 MHz to 4.6875 GHz
Differential input return loss	RL _{SDD11}		–8 + 16.6 x log(f/4.6875)	dB	4.6875 GHz to 6.25 GHz
Common-mode return loss	RL _{SCC11}		–6	dB	100 MHz to 4.6875 GHz
Random jitter	RJ		0.15	UI _{P,P}	
Uncorrelated bounded high-probability jitter	UBHPJ		0.15	UI _{P,P}	
Correlated bounded high-probability jitter	CBHPJ		0.30	UI _{P,P}	
Total jitter	TJ		0.60	UI _{P,P}	
Eye mask X1	R_X1		0.30	UI _{P,P}	
Eye mask Y1	R_Y1	62.5		mV	
Eye mask Y2	R_Y2		375	mV	

The following table lists the host-side 3.125 Gbps receiver characteristics when operating in XAUI mode following IEEE 802.3 clauses 47, 54, and 71.

Table 35 • Host-Side XAUI Receiver AC Characteristics

Parameter	Symbol	Minimum	Maximum	Unit	Condition
Data rate		3.125 – 100 ppm	3.125 + 100 ppm	Gbps	
Differential peak-to-peak input voltage	V _{I_DIFF}	75	1600	mV	AC-coupled, measured peak-to-peak each side (both sides driven)
Differential input return loss	RL _{SDD11}		–10	dB	100 MHz to 2.5 GHz
Common-mode return loss	RL _{SCC11}		–6	dB	100 MHz to 2.5 GHz
Random jitter	RJ		0.18	UI _{P,P}	

Table 35 • Host-Side XAUI Receiver AC Characteristics (continued)

Parameter	Symbol	Minimum	Maximum	Unit	Condition
Deterministic jitter	DJ		0.37	UI _{P-P}	
Total jitter tolerance ¹	TJ		0.65	UI _{P-P}	

1. Total jitter includes sinusoidal jitter according to IEEE 802.3 clause 47.3.4.6.

The following illustration shows the sinusoidal jitter tolerance for the XAUI receiver input.

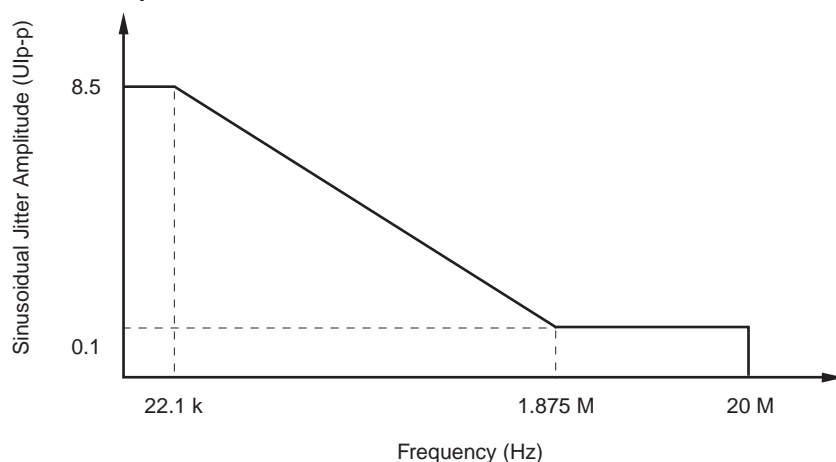
Figure 36 • XAUI Receiver Input Sinusoidal Jitter Tolerance

The following table lists the line-side 1.25 Gbps SFI input specifications for the VSC8489-02 device.

Table 36 • Line-Side 1.25 Gbps SFI Input AC Characteristics

Parameter	Symbol	Minimum	Typical	Maximum	Unit	Condition
RXIN input data rate, 1.25 Gbps		1.25 – 100 ppm	1.25	1.25 + 100 ppm	Gbps	1.25 Gbps mode
Differential input return loss	RL _{SDD11}			-10	dB	50 MHz to 625 MHz
Differential input return loss	RL _{SDD11}			-10 + 10 x log(f/625 MHz)	dB	625 MHz to 1250 MHz
Total jitter tolerance	TJ _T			0.749	UI	Jitter above 637 kHz (IEEE 802.3 clause 38.5)
Deterministic jitter	DJ			0.462	UI _{P-P}	Jitter above 637 kHz (IEEE 802.3 clause 38.5)
Eye mask Y1	Y1	125			mV	
Eye mask Y2	Y2		600		mV	

The host-side 1.25 Gbps receiver operating in 1000BASE-KX mode complies with IEEE 802.3 clause 70.

Table 37 • Host-Side 1.25 Gbps (1000BASE-KX) Receiver Input AC Characteristics

Parameter	Symbol	Minimum	Maximum	Unit	Condition
Data rate		1.25 – 100 ppm	1.25 + 100 ppm	Gbps	
Differential input return loss	RL_{SDD11}		–10	dB	50 MHz to 625 MHz
Differential input return loss	RL_{SDD11}		$-10 + 10 \times \log(f/625 \text{ MHz})$	dB	625 MHz to 1250 MHz
Total jitter tolerance ¹	TOL_{TJ}		0.749	UI	Measured according to IEEE 802.3 clause 38.5
Deterministic jitter tolerance ¹	TOL_{DJ}		0.462	UI	Measured according to IEEE 802.3 clause 38.5

1. Jitter requirements represent high-frequency jitter (above 637 kHz) and not low-frequency jitter or wander.

5.2.2 Transmitter Specifications

This section includes the transmitter specifications.

The specifications in the following table correspond to line-side 10G transmitter output, SFI point B. Point B is after a standard-compliant SFI or XFI channel, as defined in the SFP+ standard (SFF-8431) or the XFP multisource agreement (INF-8077i). The measurement is done with a 9 dB channel loss unless stated otherwise.

Table 38 • Line-Side 10G Transmitter Output (SFI Point B) AC Characteristics

Parameter	Symbol	Minimum	Maximum	Unit	Condition
Termination mismatch	ΔZ_M		5	%	
AC common-mode voltage	V_{OCM_AC}		15	mV _{RMS}	
Differential return loss	SDD22		–12	dB	0.01 GHz to 2.0 GHz
Differential return loss	SDD22		See note ¹	dB	2.0 GHz to 11.1 GHz
Common-mode return loss	SCC22		See note ²	db	0.01 GHz to 2.5 GHz
Common-mode return loss	SCC22		–3	db	2.5 GHz to 11.1 GHz
Total jitter	TJ		0.28	UI	
Data-dependent jitter	DDJ		0.1	UI	
Pulse shrinkage jitter	DDPWS		0.055	UI	
Uncorrelated jitter	UJ		0.023	UI _{RMS}	
Eye mask X1	X1		0.12	UI	
Eye mask X2	X2		0.33	UI	
Eye mask Y1	Y1	95		mV	
Eye mask Y2	Y2		350	mV	

1. Reflection coefficient given by the equation $SDD22(\text{dB}) = -6.68 + 12.1 \log_{10}(f/5.5)$, with f in GHz.

2. S-parameter equation $SCC22(\text{dB}) = -7 + 1.6 \times f$, with f in GHz.

The following illustration shows the compliance mask associated with the Tx SFI transmit differential output.

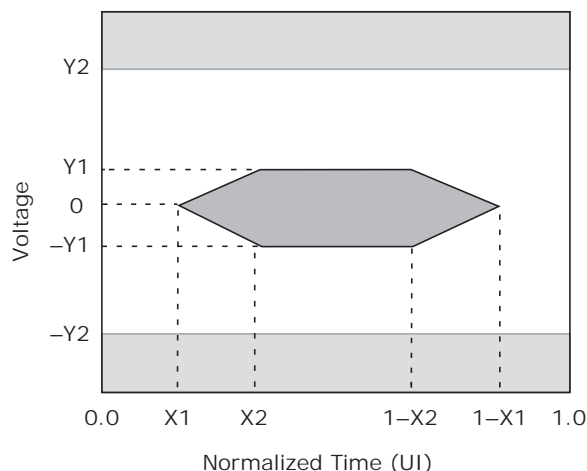
Figure 37 • SFI Transmit Differential Output Compliance Mask

The following table shows the transmit path output specifications for SFI point B with 7 dB SFI channel loss.

Table 39 • Transmitter SFP+ Direct Attach Copper Output AC Characteristics

Parameter	Symbol	Minimum	Maximum	Unit	Condition
SFP+ direct attach copper voltage modulation amplitude, peak-to-peak	V_{MA}	300		mV	See SFF-8431 section D.7.
SFP+ direct attach copper transmitter Q_{SQ}	Q_{SQ}	63.1			See SFF-8431 section D.8.
SFP+ direct attach copper output AC common-mode voltage			12	mV (RMS)	See SFF-8431 section D.15.
SFP+ direct attach copper host output TWDPc	TWDPc		10.7	dB	Electrical output measured using SFF-8431 Appendix G, including copper direct attach stressor.

The following table shows that the 10 Gbps transmitter operating in 10GBASE-KR mode complies with IEEE 802.3 clause 72.7.

Table 40 • 10 Gbps Transmitter 10GBASE-KR AC Characteristics

Parameter	Symbol	Minimum	Maximum	Unit	Condition
Signalling speed	T_{BAUD}	10.3125 – 100 ppm	10.3125 + 100 ppm	Gbps	
Differential output return loss	RLO_{SDD22}	9 9 – 12 x log(f/2.5)		dB	50 MHz to 2.5 GHz 2.5 GHz to 7.5 GHz $R_L = 100 \Omega \pm 1\%$
Common mode return loss	RLO_{CM}	6 6 – 12 x log(f/2.5)		dB	50 MHz to 2.5 GHz 2.5 GHz to 7.5 GHz $R_L = 100 \Omega \pm 1\%$
Transition time	T_R, T_F	24	47	ps	20% to 80%

Table 40 • 10 Gbps Transmitter 10GBASE-KR AC Characteristics (continued)

Parameter	Symbol	Minimum	Maximum	Unit	Condition
Random jitter	RJ		0.15	UI	BER 1E-12
Deterministic jitter	DJ		0.15	UI	
Duty cycle distortion (part of DJ)	DCD		0.035	UI	
Total jitter	TJ		0.28	UI	

The following table shows the transmit path SONET jitter specifications for point A, measured with register optimization and using a clock rate of 156.25 MHz or 155.52 MHz.

Table 41 • Line-Side SONET 10G Output Jitter AC Characteristics

Parameter	Symbol	Maximum	Unit
Total jitter, 20 kHz to 80 MHz	TJ	150	mUI
Total jitter, 4 MHz to 80 MHz	TJ	80	mUI

The near-end 6.25 Gbps transmitter output operating in RXAUI mode complies with the AC characteristics specified for CEI-6G-SR interfaces according to OIF-CEI-02.0.

Table 42 • Near-end RXAUI Transmitter Output AC Characteristics

Parameter	Symbol	Minimum	Maximum	Unit	Condition
Data rate		6.25 – 100 ppm	6.25 + 100 ppm	Gbps	
Differential output return loss	RLO_{SDD22}		-8	dB	100 MHz to 4.6875 GHz
Differential output return loss	RLO_{SDD22}		$-8 + 16.6 \times \log(f/4.6875)$	dB	4.6875 GHz to 6.25 GHz
Common-mode output return loss	RLO_{SCC22}		-6	dB	100 MHz to 4.6875 GHz
Rise time and fall time	t_R, t_F	30	130	ps	20% to 80%
Uncorrelated bounded high-probability jitter	UBHPJ		0.15	UI _{P-P}	
Duty cycle distortion	DCD		0.05	UI _{P-P}	
Total jitter	TJ		0.30	UI _{P-P}	
Eye mask X1	X1		0.15	UI _{P-P}	
Eye mask X2	X2		0.40	UI _{P-P}	
Eye mask Y1	Y1	200		mV	
Eye mask Y2	Y2		375	mV	

The far-end 6.25 Gbps transmitter output operating in RXAUI mode complies with the AC characteristics specified for CEI-6G-SR interfaces according to OIF-CEI-02.0.

Table 43 • Far-end RXAUI Transmitter Output AC Characteristics

Parameter	Symbol	Minimum	Maximum	Unit	Condition
Uncorrelated bounded high-probability jitter	UBHPJ		0.15	UI _{P-P}	

Table 43 • Far-end RXAUI Transmitter Output AC Characteristics (continued)

Parameter	Symbol	Minimum	Maximum	Unit	Condition
Correlated bounded high-probability jitter	CBHPJ		0.30	UI _{P,P}	
Total jitter	TJ		0.60	UI _{P,P}	
Eye mask X1	R_X1		0.30	UI _{P,P}	
Eye mask Y1	R_Y1	62.5		mV	
Eye mask Y2	R_Y2		375	mV	

The following table lists the far-end XAUI output specifications for the VSC8489-02 device.

Table 44 • Far-end XAUI Transmitter Output AC Characteristics

Parameter	Symbol	Minimum	Maximum	Unit	Condition
Data rate		3.125 – 100 ppm	3.125 + 100 ppm	Gbps	
Differential output voltage	V _{OUT_DIFF}	600	1600	mV	Near-end
Differential output return loss	RLO _{SDD11}		–10	dB	312.5 MHz to 625 MHz
Differential output return loss	RLO _{SDD11}		–10 + 10 x log(f/625 MHz)	dB	625 MHz to 3.125 GHz
Rise time and fall time	t _R , t _F	60	130	ps	20% to 80%
Total jitter	TJ		0.55	UI	
Deterministic jitter	DJ		0.37	UI	
Eye mask X1	X1		0.275	UI	
Eye mask X2	X2		0.4	UI	
Eye mask A1	A1	100		mV	
Eye mask A2	A2		800	mV	

The following illustration shows the compliance mask for the XAUI output.

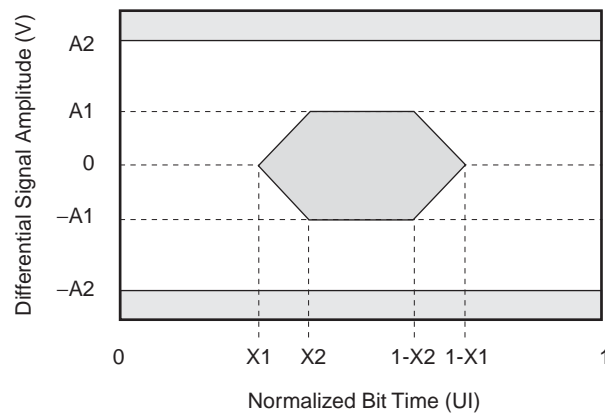
Figure 38 • XAUI Output Compliance Mask

The following table lists the line-side 1.25 Gbps SFI output specifications for the VSC8489-02 device.

Table 45 • Line-Side 1.25 Gbps SFI Output AC Characteristics

Parameter	Symbol	Minimum	Maximum	Unit	Condition
Differential output return loss	RLO_{SDD22}		-10	dB	50 MHz to 625 MHz
Differential output return loss	RLO_{SDD22}		$-10 + 10 \times \log(f/625 \text{ MHz})$	dB	625 MHz to 1250 MHz
Common mode return loss	RLO_{CM}		-6	dB	50 MHz to 625 MHz
Deterministic jitter	DJ		0.1	UI	Measured according to IEEE 802.3 clause 38.5
Total jitter	TJ		0.24	UI	Measured according to IEEE 802.3 clause 38.5
Eye mask Y1	Y1	150		mV	SFF-8431 1G specification
Eye mask Y2	Y2		500	mV	SFF-8431 1G specification

The host-side transmitter operating in 1000BASE-KX mode complies with IEEE 802.3 clause 70.

Table 46 • Host-Side Transmitter 1000BASE-KX AC Characteristics

Parameter	Symbol	Minimum	Maximum	Unit	Condition
Data rate		1.25 – 100 ppm	1.25 + 100 ppm	Gbps	
Differential output return loss	RLO_{SDD22}		-10	dB	50 MHz to 625 MHz
Differential output return loss	RLO_{SDD22}		$-10 + 10 \times \log(f/625 \text{ MHz})$	dB	625 MHz to 1250 MHz
Random jitter	RJ		0.15	UI _{P-P}	At BER 10^{-12}
Deterministic jitter	DJ		0.10	UI _{P-P}	
Total jitter	TJ		0.25	UI _{P-P}	

5.2.3 Timing and Reference Clock

The following table lists the reference clock specifications (XREFCK, SREFCK, and WREFCK) for the VSC8489-02 device.

Table 47 • Reference Clock AC Characteristics

Parameter	Symbol	Minimum	Typical	Maximum	Unit	Condition
XREFCK, SREFCK, and WREFCK frequency ¹	f_{REFCLK}	120		156.25	MHz	
XREFCK, SREFCK, and WREFCK frequency accuracy ¹	f_R	- 100 ppm		100 ppm	MHz	
Rise time and fall time	t_R, t_F			0.4	ns	Within ± 200 mV relative to VDD x 2/3
XREFCK and WREFCK Clock duty cycle	DC	40		60	%	At 50% threshold

Table 47 • Reference Clock AC Characteristics (continued)

Parameter	Symbol	Minimum	Typical	Maximum	Unit	Condition
SREFCK Clock duty cycle	DC_{SREFCK}	45		55	%	At 50% threshold
Jitter tolerance for XREFCLK, WREFCLK, and SREFCLK	JTL_{XREF}			0.7	ns	For frequency 2 KHz to 20 MHz

- XREFCK (LAN mode applications) frequency may be set to 125 MHz or 156.25 MHz. WREFCK (LAN or WAN mode Synchronous Ethernet applications) frequency may be set to 155.52 MHz. SREFCK (LAN mode Synchronous Ethernet applications) frequency is 156.25 MHz.

The following illustration shows the worst-case clock jitter transfer characteristic for the XREFCK input.

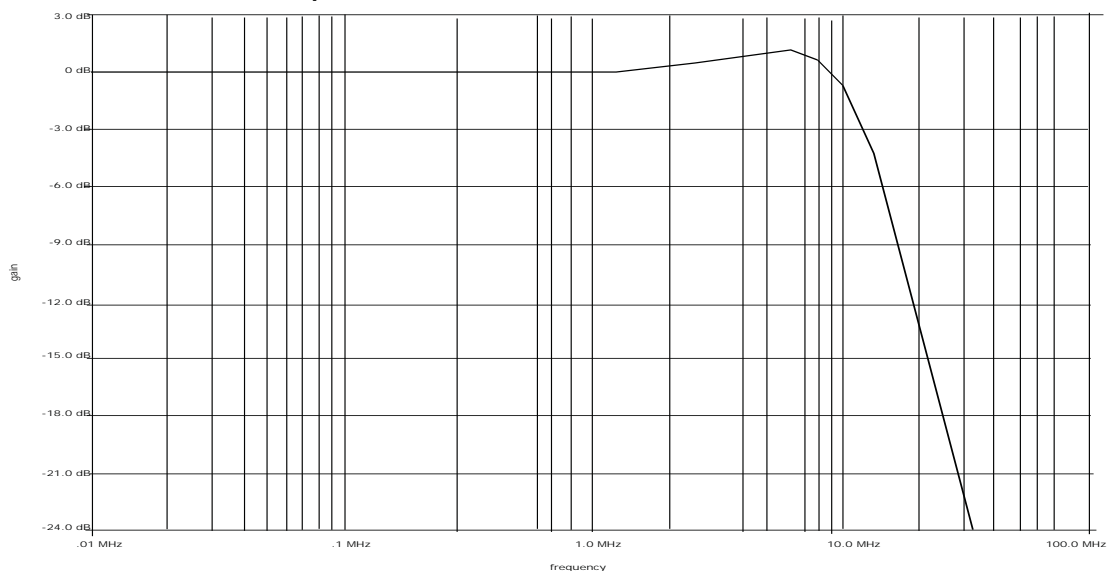
Figure 39 • XREFCK to Data Output Jitter Transfer

5.2.4 Two-Wire Serial (Slave) Interface

This section contains information about the AC specifications for the two-wire serial slave interface for the VSC8489-02 device.

Table 48 • Two-Wire Serial Interface AC Characteristics

Parameter	Symbol	Standard		Fast Mode		Unit
		Minimum	Maximum	Minimum	Maximum	
Serial clock frequency	f_{SCL}		100		400	kHz
Hold time START condition after this period, the first clock pulse is generated	$t_{HD:STA}$	4.0		0.6		μ s
Low period of SCL	t_{LOW}	4.7		1.3		μ s
High period of SCL	t_{HIGH}	4.0		0.6		μ s
Data hold time	$t_{HD:DAT}$	0	3.45	0	0.9	μ s
Data setup time	$t_{SU:DAT}$	250		100		ns
Rise time for SDA and SCL	t_R		1000		300	ns
Fall time for SDA and SCL	t_F		300		300	ns

Table 48 • Two-Wire Serial Interface AC Characteristics (continued)

Parameter	Symbol	Standard		Fast Mode		Unit
		Minimum	Maximum	Minimum	Maximum	
Setup time for STOP condition	$t_{SU:STO}$	4.0		0.6		μs
Bus free time between a STOP and START	t_{BUF}	4.7		1.3		μs
Capacitive load for SCL and SDA bus line	C_B		400		330	pF
External pull-up resistor ¹	R_P	900	$8 \times 10^{-7}/C_B$	900	$3 \times 10^{-7}/C_B$	Ω

1. Minimum value is determined from I_{OL} and internal reliability requirements. Maximum value is determined by load capacitance. Microsemi recommends 10 k Ω for typical applications in which capacitance loads are below the specified minimums.

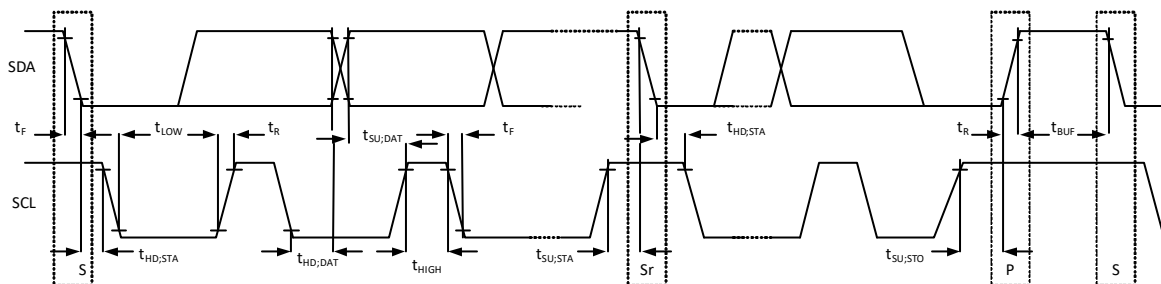
Figure 40 • Two-Wire Serial Interface Timing

S = START, P = STOP, and Sr = repeated START.

5.2.5 MDIO Interface

This section contains information about the AC specifications for the MDIO interface for the VSC8489-02 device.

Table 49 • MDIO Interface AC Characteristics

Parameter	Symbol	Minimum	Maximum	Unit
MDIO data hold time	t_{HOLD}	10		ns
MDIO data setup time	t_{SU}	10		ns
Delay from MDC rising edge to MDIO data change	t_{DELAY}		300	ns
MDC clock rate	f		2.5	MHz

The following illustration shows the timing with the MDIO sourced by STA.

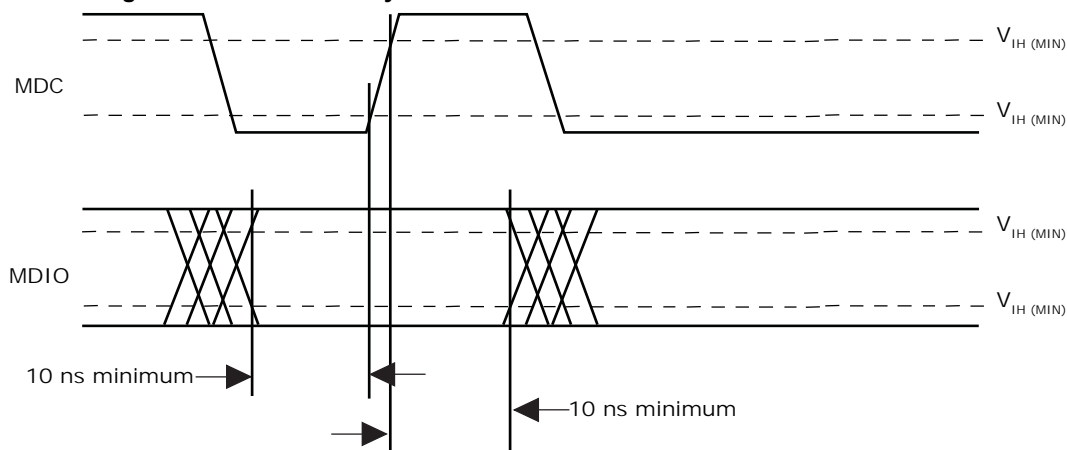
Figure 41 • Timing with MDIO Sourced by STA

The following illustration shows the timing with the MDIO sourced by MMD.

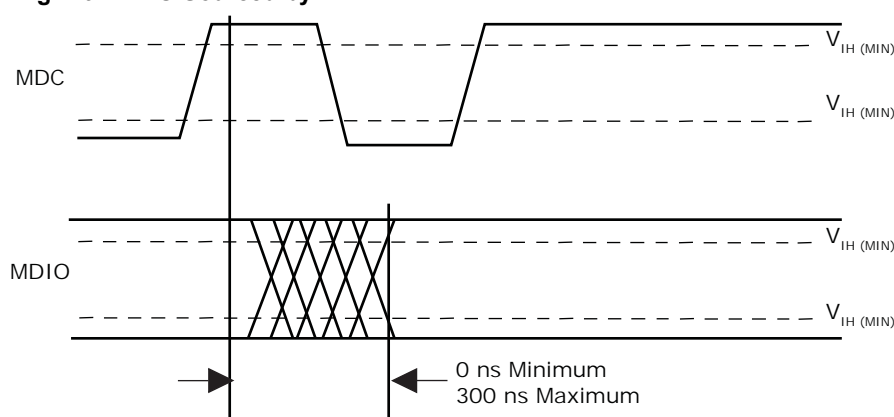
Figure 42 • Timing with MDIO Sourced by MMD

The following table lists the clock output specifications (RX0CKOUT, RX1CKOUT, TX0CKOUT, TX1CKOUT) for the VSC8489-02 device.

Table 50 • Clock Output AC Characteristics

Parameter	Symbol	Minimum	Maximum	Unit	Condition
RX0CKOUT, RX1CKOUT, TX0CKOUT, and TX1CKOUT jitter generation	JG_{C64}		10	ps _{RMS}	from 10 KHz to 10 MHz
RX0CKOUT, RX1CKOUT, TX0CKOUT, and TX1CKOUT differential output swing	ΔV	650	900	mV _{P-P}	

5.2.6 SPI Slave Interface

This section contains information about the AC specifications for the four-pin SPI slave interface used to read and write registers. The maximum clock rate is 30 MHz and it is configurable.

Table 51 • SPI Slave Interface AC Characteristics

Parameter	Symbol	Minimum	Maximum	Unit	Condition
MOSI data setup time	$t_{SU, MOSI}$	10		ns	
MOSI data hold time	$t_{HD, MOSI}$	10		ns	

Table 51 • SPI Slave Interface AC Characteristics (continued)

SSN data setup time	$t_{SU, SSN}$	15		ns	SSN transition low to enable interface
SSN data hold time	$t_{HD, SSN}$	SCK clock period + 15.0		ns	SSN transition high to enable interface
SSN transition low to MISO valid	$t_{ON, MISO}$		17	ns	
SSN transition high to MISO high impedance	$t_{OFF, MISO}$	18		ns	
Falling SCK to valid MISO data, normal mode	$t_{DLY, NORM}$	14	30	ns	Maximum capacitance loading of 5 pF
Rising SCK to valid MISO data, fast mode	$t_{DLY, FAST}$	14	30	ns	Maximum capacitance loading of 5 pF

The following illustration shows the SPI interface timing.

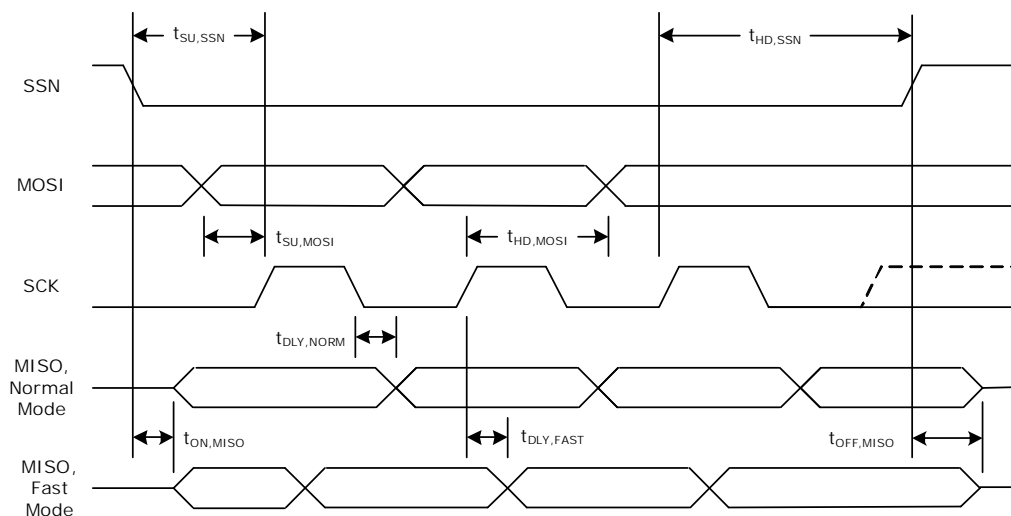
Figure 43 • SPI Interface Timing

The following table lists the AC characteristics for the 3-pin push-out SPI.

Table 52 • 3-Pin Push-Out SPI AC Characteristics

Parameter	Symbol	Minimum	Maximum	Unit
SPI_DO to SPI_CLK delay	$t_{DO, CLK}$	-1	6.5	ns
SPI_CS to SPI_CLK delay	$t_{CS, CLK}$	0.5	8	ns

The following illustration shows the 3-pin push-out SPI timing.

Figure 44 • 3-Pin Push-Out SPI Timing

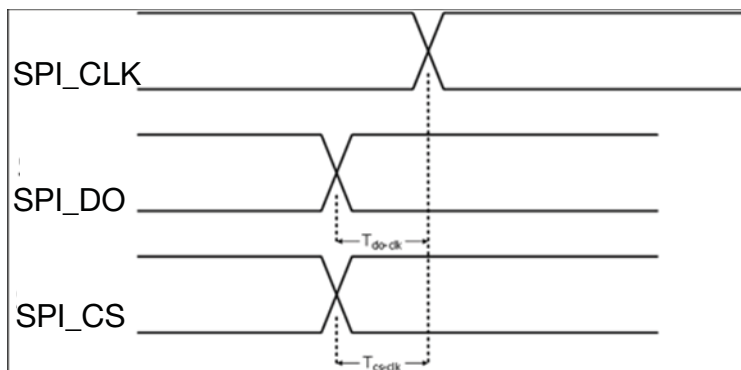

5.3 Operating Conditions

To ensure that the control pins remain set to the desired configured state when the VSC8489-02 device is powered up, perform a reset using the reset pin after power-up and after the control pins are steady for 1 ms.

Table 53 • Recommended Operating Conditions

Parameter	Symbol	Minimum	Typical	Maximum	Unit	Condition
1.0 V power supply voltage	V_{DDAH} V_{DDAL} V_{DDL}	0.95	1.0	1.05	V	
1.2 V power supply voltage	V_{DDHSL}	1.14	1.2	1.26	V	
1.2 V power supply current	I_{DD12}		98	150	mA	
2.5 V TTL I/O power supply voltage	V_{DDTTL} V_{DDMDIO}	2.375	2.5	2.625	V	
TTL I/O power supply current	I_{DDTTL}		40		mA	
Operating temperature ¹	T	-40		110	°C	

1. Minimum specification is ambient temperature, and the maximum is junction temperature.

5.4 Stress Ratings

This section contains the stress ratings for the VSC8489-02 device.

Warning Stresses listed in the following table may be applied to devices one at a time without causing permanent damage. Functionality at or exceeding the values listed is not implied. Exposure to these values for extended periods may affect device reliability

Table 54 • Stress Ratings

Parameter	Symbol	Minimum	Maximum	Unit
1.0 V power supply voltage, potential to ground	V_{DDAH} V_{DDAL} V_{DDL}	-0.3	1.1	V
1.2 V power supply voltage, potential to ground	V_{DDHSL}	-0.3	1.32	V
2.5 V TTL I/O power supply voltage	V_{DDTTL} V_{DDMDIO}	-0.3	2.75	V
Storage temperature	T_S	-55	125	°C

Table 54 • Stress Ratings (continued)

Electrostatic discharge voltage, charged device model	V_{ESD_CDM}	-250	250	V
Electrostatic discharge voltage, human body model	V_{ESD_HBM}	See note ¹		V

1. This device has completed all required testing as specified in the JEDEC standard JESD22-A114, Electrostatic Discharge (ESD) Sensitivity Testing Human Body Model (HBM), and complies with a Class 2 rating. The definition of Class 2 is any part that passes an ESD pulse of 2000 V, but fails an ESD pulse of 4000 V.

Warning This device can be damaged by electrostatic discharge (ESD) voltage. Microsemi recommends that all integrated circuits be handled with appropriate precautions. Failure to observe proper handling and installation procedures may adversely affect reliability of the device.

6 Pin Descriptions

The VSC8489-02 device has 196 pins, which are described in this section.

The pin information is also provided as an attached Microsoft Excel file, so that you can copy it electronically. In Adobe Reader, double-click the attachment icon.

6.1 Pin Diagram

The following illustration is a representation of the VSC8489-02 device, as seen from the top view.

Figure 45 • Pin Diagram

	1	2	3	4	5	6	7	8	9	10	11	12	13	14
A	GND	GND	XTX0_3P	XTX0_2P	XTX0_1P	XTX0_0P	TDIOP	RX0CKOUTN	GND	TX0CKOUTN	GND	GND	GND	GND
B	GND	GND	XTX0_3N	XTX0_2N	XTX0_1N	XTX0_0N	TDION	RX0CKOUTP	GND	TX0CKOUTP	GND	GND	RXIN0N	RXIN0P
C	XRX0_0P	XRX0_0N	GND	GND	GND	RESETN	VDDMDIO	PADDR2	VDDTTL	GPIO_12	GPIO_13	GND	GND	GND
D	XRX0_1P	XRX0_1N	GND	GPIO_0	GPIO_1	LOPC0	MDC	NC	SSN	PADDR1	SCK	GND	TXOUT0P	TXOUT0N
E	XRX0_2P	XRX0_2N	GND	GPIO_2	GPIO_3	PADDR4	MDIO	NC	MOSI	PADDR3	MISO	GND	GND	GND
F	XRX0_3P	XRX0_3N	GND	GPIO_4	GPIO_5	GND	VDDAL	GND	VDDHSL	VDDHSL	GND	GND	XREFCKP	XREFCKN
G	GND	GND	GND	VDDAH	VDDAH	GND	VDDAL	GND	VDDAL	VDDHSL	GND	GND	GND	GND
H	XTX1_0P	XTX1_0N	GND	VDDL	VDDL	GND	VDDL	GND	VDDAL	VDDHSL	GND	SREFCKP	GND	WREFCKP
J	XTX1_1P	XTX1_1N	GND	VDDAH	VDDAH	GND	VDDAL	GND	VDDHSL	VDDHSL	GND	SREFCKN	GND	WREFCKN
K	XTX1_2P	XTX1_2N	GND	GPIO_6	GPIO_7	GPIO_8	NC	TDO	TCK	TRSTB	MODE0	GND	GND	GND
L	XTX1_3P	XTX1_3N	GND	GPIO_9	GPIO_10	GPIO_11	NC	TDI	SCAN_EN	NC	RCOMPP	GND	RXIN1P	RXIN1N
M	GND	GND	GND	GND	TMS	VDDTTL	LOPC1	NC	MODE1	GND	RCOMPN	GND	GND	GND
N	GND	XRX1_0P	XRX1_1P	XRX1_2P	XRX1_3P	GND	RX1CKOUTP	GND	TX1CKOUTP	GND	GPIO_14	GND	TXOUT1N	TXOUT1P
P	GND	XRX1_0N	XRX1_1N	XRX1_2N	XRX1_3N	GND	RX1CKOUTN	GND	TX1CKOUTN	GND	GPIO_15	GND	GND	GND

6.2 Pin Identifications

This section contains the pin descriptions for the device, sorted according to their functional group.

The following table lists the definitions for the pin type symbols.

Table 55 • Pin Identifications

Symbol	Pin Type	Description
A	Analog I/O	Analog input for sensing variable voltage levels.
I	Input	Input signal.
O	Output	Output signal.
B	Bidirectional	Bidirectional input or output signal.
CML	Current mode logic	
NC	No connect	
LVTTTL	Low voltage transistor-to-transistor logic	
LVTTLOD	Low-voltage transistor-to-transistor logic with open-drain output	

6.3 Pins by Function

This section contains the functional pin descriptions for the VSC8489-02 device.

Note: All the differential clock signals and differential data signals should be AC-coupled. A cap of 0.1 uF would be sufficient.

Functional Group Name	Number	Type	Level	Description	
1588	CLK1588N	E8	I	CML	1588 logic clock input, complement
1588	CLK1588P	D8	I	CML	1588 logic clock input, true
1588	SPI_CLK	K7	O	LVTTTL	Pushout SPI clock output for 1588 timestamp
1588	SPI_CS	L10	O	LVTTTL	Pushout SPI chip select output for 1588 timestamp
1588	SPI_DO	L7	O	LVTTTL	Pushout SPI data output for 1588 timestamp
Clock Signal	RX0CKOUTN	A8	O	CML	Selectable clock output channel 0, complement. See register device 1, address A008.
Clock Signal	RX0CKOUTP	B8	O	CML	Selectable clock output channel 0, true. See register device 1, address A008.
Clock Signal	SREFCKN	J12	I	CML	SyncE reference clock input, complement
Clock Signal	SREFCKP	H12	I	CML	SyncE reference clock input, true
Clock Signal	TX0CKOUTN	A10	O	CML	Selectable clock output channel 0, complement. See register device 1, address A009.
Clock Signal	TX0CKOUTP	B10	O	CML	Selectable clock output channel 0, true. See register device 1, address A009.
Clock Signal	WREFCKN	J14	I	CML	WAN reference clock input, complement
Clock Signal	WREFCKP	H14	I	CML	WAN reference clock input, true
Clock Signal	XREFCKN	F14	I	CML	Reference clock input, complement
Clock Signal	XREFCKP	F13	I	CML	Reference clock input, true
JTAG	TCK	K9	I	LVTTTL	Boundary scan, test clock input. Internally pulled high.
JTAG	TDI	L8	I	LVTTTL	Boundary scan, test data input. Internally pulled high.
JTAG	TDO	K8	O	LVTTTL	Boundary scan, test data output.

JTAG	TMS	M5	I	LVTTTL	Boundary scan, test mode select. Internally pulled high.
JTAG	TRSTB	K10	I	LVTTTL	Boundary scan, test reset input. Internally pulled high.
MDIO	MDC	D7	I	LVTTTL	MDIO clock input
MDIO	MDIO	E7	B	LVTTLOD	MDIO data I/O
Miscellaneous	GPIO_0	D4	B	LVTTLOD	General purpose I/O 0
Miscellaneous	GPIO_1	D5	B	LVTTLOD	General purpose I/O 1
Miscellaneous	GPIO_2	E4	B	LVTTLOD	General purpose I/O 2
Miscellaneous	GPIO_3	E5	B	LVTTLOD	General purpose I/O 3
Miscellaneous	GPIO_4	F4	B	LVTTLOD	General purpose I/O 4
Miscellaneous	GPIO_5	F5	B	LVTTLOD	General purpose I/O 5
Miscellaneous	GPIO_6	K4	B	LVTTLOD	General purpose I/O 6
Miscellaneous	GPIO_7	K5	B	LVTTLOD	General purpose I/O 7
Miscellaneous	GPIO_8	K6	B	LVTTLOD	General purpose I/O 8
Miscellaneous	GPIO_9	L4	B	LVTTLOD	General purpose I/O 9
Miscellaneous	GPIO_10	L5	B	LVTTLOD	General purpose I/O 10
Miscellaneous	GPIO_11	L6	B	LVTTLOD	General purpose I/O 11
Miscellaneous	GPIO_12	C10	B	LVTTLOD	General purpose I/O 12
Miscellaneous	GPIO_13	C11	B	LVTTLOD	General purpose I/O 13
Miscellaneous	GPIO_14	N11	B	LVTTLOD	General purpose I/O 14
Miscellaneous	GPIO_15	P11	B	LVTTLOD	General purpose I/O 15
Miscellaneous	MODE0	K11	I	LVTTTL	Mode select input bit 0
Miscellaneous	MODE1	M9	I	LVTTTL	Mode select input bit 1
Miscellaneous	PADDR1	D10	I	LVTTTL	MDIO port address bit 1. Internally pulled low.
Miscellaneous	PADDR2	C8	I	LVTTTL	MDIO port address bit 2. Internally pulled low.
Miscellaneous	PADDR3	E10	I	LVTTTL	MDIO port address bit 3. Internally pulled low.
Miscellaneous	PADDR4	E6	I	LVTTTL	MDIO port address bit 4. Internally pulled low.
Miscellaneous	RCOMP_N	M11		Analog	Resistor comparator, complement
Miscellaneous	RCOMP_P	L11		Analog	Resistor comparator, truth
Miscellaneous	RESET_N	C6	I	LVTTTL	Reset. Low= reset. Internally pulled high.
Miscellaneous	SCAN_EN	L9	I	LVTTTL	Scan enable input, factory test purposes only. Keep connected to Ground.
Miscellaneous	TDION	B7		Analog	Temperature diode, complement
Miscellaneous	TDIOP	A7		Analog	Temperature diode, truth
Power and Ground	GND	A1	P	GND	Ground
Power and Ground	GND	A2	P	GND	Ground
Power and Ground	GND	A9	P	GND	Ground
Power and Ground	GND	A11	P	GND	Ground
Power and Ground	GND	A12	P	GND	Ground

Power and Ground GND	A13	P	GND	Ground
Power and Ground GND	A14	P	GND	Ground
Power and Ground GND	B1	P	GND	Ground
Power and Ground GND	B2	P	GND	Ground
Power and Ground GND	B9	P	GND	Ground
Power and Ground GND	B11	P	GND	Ground
Power and Ground GND	B12	P	GND	Ground
Power and Ground GND	C4	P	GND	Ground
Power and Ground GND	C5	P	GND	Ground
Power and Ground GND	C12	P	GND	Ground
Power and Ground GND	C13	P	GND	Ground
Power and Ground GND	C14	P	GND	Ground
Power and Ground GND	D3	P	GND	Ground
Power and Ground GND	D12	P	GND	Ground
Power and Ground GND	E3	P	GND	Ground
Power and Ground GND	E12	P	GND	Ground
Power and Ground GND	E13	P	GND	Ground
Power and Ground GND	E14	P	GND	Ground
Power and Ground GND	F3	P	GND	Ground
Power and Ground GND	F6	P	GND	Ground
Power and Ground GND	F8	P	GND	Ground
Power and Ground GND	F11	P	GND	Ground
Power and Ground GND	F12	P	GND	Ground
Power and Ground GND	G1	P	GND	Ground
Power and Ground GND	G2	P	GND	Ground
Power and Ground GND	G3	P	GND	Ground
Power and Ground GND	G6	P	GND	Ground

Power and Ground GND	G8	P	GND	Ground
Power and Ground GND	G11	P	GND	Ground
Power and Ground GND	G12	P	GND	Ground
Power and Ground GND	G13	P	GND	Ground
Power and Ground GND	G14	P	GND	Ground
Power and Ground GND	H3	P	GND	Ground
Power and Ground GND	H6	P	GND	Ground
Power and Ground GND	H8	P	GND	Ground
Power and Ground GND	H11	P	GND	Ground
Power and Ground GND	H13	P	GND	Ground
Power and Ground GND	J3	P	GND	Ground
Power and Ground GND	J6	P	GND	Ground
Power and Ground GND	J8	P	GND	Ground
Power and Ground GND	J11	P	GND	Ground
Power and Ground GND	J13	P	GND	Ground
Power and Ground GND	K3	P	GND	Ground
Power and Ground GND	K12	P	GND	Ground
Power and Ground GND	K13	P	GND	Ground
Power and Ground GND	K14	P	GND	Ground
Power and Ground GND	L3	P	GND	Ground
Power and Ground GND	L12	P	GND	Ground
Power and Ground GND	M1	P	GND	Ground
Power and Ground GND	M2	P	GND	Ground
Power and Ground GND	M3	P	GND	Ground
Power and Ground GND	M4	P	GND	Ground
Power and Ground GND	M10	P	GND	Ground
Power and Ground GND	M12	P	GND	Ground

Power and Ground GND	M13	P	GND	Ground
Power and Ground GND	M14	P	GND	Ground
Power and Ground GND	N1	P	GND	Ground
Power and Ground GND	N6	P	GND	Ground
Power and Ground GND	N8	P	GND	Ground
Power and Ground GND	N10	P	GND	Ground
Power and Ground GND	N12	P	GND	Ground
Power and Ground GND	P1	P	GND	Ground
Power and Ground GND	P6	P	GND	Ground
Power and Ground GND	P8	P	GND	Ground
Power and Ground GND	P10	P	GND	Ground
Power and Ground GND	P12	P	GND	Ground
Power and Ground GND	P13	P	GND	Ground
Power and Ground GND	P14	P	GND	Ground
Power and Ground VDDAH	G4	P	Supply	1.0 V power supply for host side analog
Power and Ground VDDAH	G5	P	Supply	1.0 V power supply for host side analog
Power and Ground VDDAH	J4	P	Supply	1.0 V power supply for host side analog
Power and Ground VDDAH	J5	P	Supply	1.0 V power supply for host side analog
Power and Ground VDDAL	F7	P	Supply	1.0 V power supply for line side analog
Power and Ground VDDAL	G7	P	Supply	1.0 V power supply for line side analog
Power and Ground VDDAL	G9	P	Supply	1.0 V power supply for line side analog
Power and Ground VDDAL	H9	P	Supply	1.0 V power supply for line side analog
Power and Ground VDDAL	J7	P	Supply	1.0 V power supply for line side analog
Power and Ground VDDHSL	F9	P	Supply	1.2 V power supply for line side IOs
Power and Ground VDDHSL	F10	P	Supply	1.2 V power supply for line side IOs
Power and Ground VDDHSL	G10	P	Supply	1.2 V power supply for line side IOs
Power and Ground VDDHSL	H10	P	Supply	1.2 V power supply for line side IOs

Power and Ground VDDHSL	J9	P	Supply	1.2 V power supply for line side IOs	
Power and Ground VDDHSL	J10	P	Supply	1.2 V power supply for line side IOs	
Power and Ground VDDL	H4	P	Supply	1.0 V power supply for chip core	
Power and Ground VDDL	H5	P	Supply	1.0 V power supply for chip core	
Power and Ground VDDL	H7	P	Supply	1.0 V power supply for chip core	
Power and Ground VDDMDIO	C7	P	Supply	MDIO power supply	
Power and Ground VDDTTL	C3	P	Supply	LVTTTL power supply	
Power and Ground VDDTTL	C9	P	Supply	LVTTTL power supply	
Power and Ground VDDTTL	M6	P	Supply	LVTTTL power supply	
Receive and Transmit Path	LOPC0	D6	I	LVTTTL	Loss of optical carrier, channel 0. Internally pulled high.
Receive and Transmit Path	RXIN0N	B13	I	CML	Receive channel 0 input data, complement
Receive and Transmit Path	RXIN0P	B14	I	CML	Receive channel 0 input data, true
Receive and Transmit Path	TXOUT0N	D14	O	CML	Transmit channel 0 output data, complement
Receive and Transmit Path	TXOUT0P	D13	O	CML	Transmit channel 0 output data, true
Reserved/No Connect	NC	L13			No connect
Reserved/No Connect	NC	L14			No connect
Reserved/No Connect	NC	M7			No connect (could also be grounded)
Reserved/No Connect	NC	M8			No connect (formerly labeled as ANATEST)
Reserved/No Connect	NC	N7			No connect
Reserved/No Connect	NC	N9			No connect
Reserved/No Connect	NC	N13			No connect
Reserved/No Connect	NC	N14			No connect
Reserved/No Connect	NC	P7			No connect
Reserved/No Connect	NC	P9			No connect
SPI	MISO	E11	O	LVTTTL	SPI slave data output
SPI	MOSI	E9	I	LVTTTL	SPI slave data input
SPI	SCK	D11	I	LVTTTL	SPI slave clock input
SPI	SSN	D9	I	LVTTTL	SPI slave chip select input

XAUI Channel	XRX0_0N	C2	I	CML	XAUI channel 0, Rx path lane 0, serial data input, complement
XAUI Channel	XRX0_0P	C1	I	CML	XAUI channel 0, Rx path lane 0, serial data input, true
XAUI Channel	XRX0_1N	D2	I	CML	XAUI channel 0, Rx path lane 1, serial data input, complement
XAUI Channel	XRX0_1P	D1	I	CML	XAUI channel 0, Rx path lane 1, serial data input, true
XAUI Channel	XRX0_2N	E2	I	CML	XAUI channel 0, Rx path lane 2, serial data input, complement
XAUI Channel	XRX0_2P	E1	I	CML	XAUI channel 0, Rx path lane 2, serial data input, true
XAUI Channel	XRX0_3N	F2	I	CML	XAUI channel 0, Rx path lane 3, serial data input, complement
XAUI Channel	XRX0_3P	F1	I	CML	XAUI channel 0, Rx path lane 3, serial data input, true
XAUI Channel	XRX1_0N	P2	I	CML	XAUI channel 1, Rx path lane 0, serial data input, complement
XAUI Channel	XRX1_0P	N2	I	CML	XAUI channel 1, Rx path lane 0, serial data input, true
XAUI Channel	XRX1_1N	P3	I	CML	XAUI channel 1, Rx path lane 1, serial data input, complement
XAUI Channel	XRX1_1P	N3	I	CML	XAUI channel 1, Rx path lane 1, serial data input, true
XAUI Channel	XRX1_2N	P4	I	CML	XAUI channel 1, Rx path lane 2, serial data input, complement
XAUI Channel	XRX1_2P	N4	I	CML	XAUI channel 1, Rx path lane 2, serial data input, true
XAUI Channel	XRX1_3N	P5	I	CML	XAUI channel 1, Rx path lane 3, serial data input, complement
XAUI Channel	XRX1_3P	N5	I	CML	XAUI channel 1, Rx path lane 3, serial data input, true
XAUI Channel	XTX0_0N	B6	O	CML	XAUI channel 0, Tx path lane 0, serial data output, complement
XAUI Channel	XTX0_0P	A6	O	CML	XAUI channel 0, Tx path lane 0, serial data output, true
XAUI Channel	XTX0_1N	B5	O	CML	XAUI channel 0, Tx path lane 1, serial data output, complement
XAUI Channel	XTX0_1P	A5	O	CML	XAUI channel 0, Tx path lane 1, serial data output, true
XAUI Channel	XTX0_2N	B4	O	CML	XAUI channel 0, Tx path lane 2, serial data output, complement
XAUI Channel	XTX0_2P	A4	O	CML	XAUI channel 0, Tx path lane 2, serial data output, true
XAUI Channel	XTX0_3N	B3	O	CML	XAUI channel 0, Tx path lane 3, serial data output, complement
XAUI Channel	XTX0_3P	A3	O	CML	XAUI channel 0, Tx path lane 3, serial data output, true
XAUI Channel	XTX1_0N	H2	O	CML	XAUI channel 1, Tx path lane 0, serial data output, complement
XAUI Channel	XTX1_0P	H1	O	CML	XAUI channel 1, Tx path lane 0, serial data output, true
XAUI Channel	XTX1_1N	J2	O	CML	XAUI channel 1, Tx path lane 1, serial data output, complement

XAUI Channel	XTX1_1P	J1	O	CML	XAUI channel 1, Tx path lane 1, serial data output, true
XAUI Channel	XTX1_2N	K2	O	CML	XAUI channel 1, Tx path lane 2, serial data output, complement
XAUI Channel	XTX1_2P	K1	O	CML	XAUI channel 1, Tx path lane 2, serial data output, true
XAUI Channel	XTX1_3N	L2	O	CML	XAUI channel 1, Tx path lane 3, serial data output, complement
XAUI Channel	XTX1_3P	L1	O	CML	XAUI channel 1, Tx path lane 3, serial data output, true

Functional Group Name	Number	Type	Level	Description	
Clock Signal	RX0CKOUTN	A8	O	CML	Selectable clock output channel 0, complement. See register device 1, address A008.
Clock Signal	RX0CKOUTP	B8	O	CML	Selectable clock output channel 0, true. See register device 1, address A008.
Clock Signal	RX1CKOUTN	P7	O	CML	Selectable clock output channel 1, complement. See register device 1, address A008.
Clock Signal	RX1CKOUTP	N7	O	CML	Selectable clock output channel 1, true. See register device 1, address A008.
Clock Signal	SREFCKN	J12	I	CML	SyncE reference clock input, complement
Clock Signal	SREFCKP	H12	I	CML	SyncE reference clock input, true
Clock Signal	TX0CKOUTN	A10	O	CML	Selectable clock output channel 0, complement. See register device 1, address A009.
Clock Signal	TX0CKOUTP	B10	O	CML	Selectable clock output channel 0, true. See register device 1, address A009.
Clock Signal	TX1CKOUTN	P9	O	CML	Selectable clock output channel 1, complement. See register device 1, address A009.
Clock Signal	TX1CKOUTP	N9	O	CML	Selectable clock output channel 1, true. See register device 1, address A009.
Clock Signal	WREFCKN	J14	I	CML	WAN reference clock input, complement
Clock Signal	WREFCKP	H14	I	CML	WAN reference clock input, true
Clock Signal	XREFCKN	F14	I	CML	Reference clock input, complement
Clock Signal	XREFCKP	F13	I	CML	Reference clock input, true
JTAG	TCK	K9	I	LVTTL	Boundary scan, test clock input. Internally pulled high.
JTAG	TDI	L8	I	LVTTL	Boundary scan, test data input. Internally pulled high.
JTAG	TDO	K8	O	LVTTL	Boundary scan, test data output.
JTAG	TMS	M5	I	LVTTL	Boundary scan, test mode select. Internally pulled high.
JTAG	TRSTB	K10	I	LVTTL	Boundary scan, test reset input. Internally pulled high.
MDIO	MDC	D7	I	LVTTL	MDIO clock input
MDIO	MDIO	E7	B	LVTTL	MDIO data I/O

Miscellaneous	GPIO_0	D4	B	LVTTL0D	General purpose I/O 0
Miscellaneous	GPIO_1	D5	B	LVTTL0D	General purpose I/O 1
Miscellaneous	GPIO_2	E4	B	LVTTL0D	General purpose I/O 2
Miscellaneous	GPIO_3	E5	B	LVTTL0D	General purpose I/O 3
Miscellaneous	GPIO_4	F4	B	LVTTL0D	General purpose I/O 4
Miscellaneous	GPIO_5	F5	B	LVTTL0D	General purpose I/O 5
Miscellaneous	GPIO_6	K4	B	LVTTL0D	General purpose I/O 6
Miscellaneous	GPIO_7	K5	B	LVTTL0D	General purpose I/O 7
Miscellaneous	GPIO_8	K6	B	LVTTL0D	General purpose I/O 8
Miscellaneous	GPIO_9	L4	B	LVTTL0D	General purpose I/O 9
Miscellaneous	GPIO_10	L5	B	LVTTL0D	General purpose I/O 10
Miscellaneous	GPIO_11	L6	B	LVTTL0D	General purpose I/O 11
Miscellaneous	GPIO_12	C10	B	LVTTL0D	General purpose I/O 12
Miscellaneous	GPIO_13	C11	B	LVTTL0D	General purpose I/O 13
Miscellaneous	GPIO_14	N11	B	LVTTL0D	General purpose I/O 14
Miscellaneous	GPIO_15	P11	B	LVTTL0D	General purpose I/O 15
Miscellaneous	MODE0	K11	I	LVTTL	Mode select input bit 0
Miscellaneous	MODE1	M9	I	LVTTL	Mode select input bit 1
Miscellaneous	PADDR1	D10	I	LVTTL	MDIO port address bit 1. Internally pulled low.
Miscellaneous	PADDR2	C8	I	LVTTL	MDIO port address bit 2. Internally pulled low.
Miscellaneous	PADDR3	E10	I	LVTTL	MDIO port address bit 3. Internally pulled low.
Miscellaneous	PADDR4	E6	I	LVTTL	MDIO port address bit 4. Internally pulled low.
Miscellaneous	RCOMP_N	M11		Analog	Resistor comparator, complement
Miscellaneous	RCOMP_P	L11		Analog	Resistor comparator, truth
Miscellaneous	RESET_N	C6	I	LVTTL	Reset. Low= reset. Internally pulled high.
Miscellaneous	SCAN_EN	L9	I	LVTTL	Scan enable input, factory test purposes only. Keep connected to Ground.
Miscellaneous	TDION	B7		Analog	Temperature diode, complement
Miscellaneous	TDIOP	A7		Analog	Temperature diode, truth
Power and Ground	GND	A1	P	GND	Ground
Power and Ground	GND	A2	P	GND	Ground
Power and Ground	GND	A9	P	GND	Ground
Power and Ground	GND	A11	P	GND	Ground
Power and Ground	GND	A12	P	GND	Ground
Power and Ground	GND	A13	P	GND	Ground
Power and Ground	GND	A14	P	GND	Ground

Power and Ground	GND	B1	P	GND	Ground
Power and Ground	GND	B2	P	GND	Ground
Power and Ground	GND	B9	P	GND	Ground
Power and Ground	GND	B11	P	GND	Ground
Power and Ground	GND	B12	P	GND	Ground
Power and Ground	GND	C3	P	GND	Ground
Power and Ground	GND	C4	P	GND	Ground
Power and Ground	GND	C5	P	GND	Ground
Power and Ground	GND	C12	P	GND	Ground
Power and Ground	GND	C13	P	GND	Ground
Power and Ground	GND	C14	P	GND	Ground
Power and Ground	GND	D3	P	GND	Ground
Power and Ground	GND	D12	P	GND	Ground
Power and Ground	GND	E3	P	GND	Ground
Power and Ground	GND	E12	P	GND	Ground
Power and Ground	GND	E13	P	GND	Ground
Power and Ground	GND	E14	P	GND	Ground
Power and Ground	GND	F3	P	GND	Ground
Power and Ground	GND	F6	P	GND	Ground
Power and Ground	GND	F8	P	GND	Ground
Power and Ground	GND	F11	P	GND	Ground
Power and Ground	GND	F12	P	GND	Ground
Power and Ground	GND	G1	P	GND	Ground
Power and Ground	GND	G2	P	GND	Ground

Power and Ground	GND	G3	P	GND	Ground
Power and Ground	GND	G6	P	GND	Ground
Power and Ground	GND	G8	P	GND	Ground
Power and Ground	GND	G11	P	GND	Ground
Power and Ground	GND	G12	P	GND	Ground
Power and Ground	GND	G13	P	GND	Ground
Power and Ground	GND	G14	P	GND	Ground
Power and Ground	GND	H3	P	GND	Ground
Power and Ground	GND	H6	P	GND	Ground
Power and Ground	GND	H8	P	GND	Ground
Power and Ground	GND	H11	P	GND	Ground
Power and Ground	GND	H13	P	GND	Ground
Power and Ground	GND	J3	P	GND	Ground
Power and Ground	GND	J6	P	GND	Ground
Power and Ground	GND	J8	P	GND	Ground
Power and Ground	GND	J11	P	GND	Ground
Power and Ground	GND	J13	P	GND	Ground
Power and Ground	GND	K3	P	GND	Ground
Power and Ground	GND	K12	P	GND	Ground
Power and Ground	GND	K13	P	GND	Ground
Power and Ground	GND	K14	P	GND	Ground
Power and Ground	GND	L3	P	GND	Ground
Power and Ground	GND	L12	P	GND	Ground
Power and Ground	GND	M1	P	GND	Ground

Power and Ground	GND	M2	P	GND	Ground
Power and Ground	GND	M3	P	GND	Ground
Power and Ground	GND	M4	P	GND	Ground
Power and Ground	GND	M10	P	GND	Ground
Power and Ground	GND	M12	P	GND	Ground
Power and Ground	GND	M13	P	GND	Ground
Power and Ground	GND	M14	P	GND	Ground
Power and Ground	GND	N1	P	GND	Ground
Power and Ground	GND	N6	P	GND	Ground
Power and Ground	GND	N8	P	GND	Ground
Power and Ground	GND	N10	P	GND	Ground
Power and Ground	GND	N12	P	GND	Ground
Power and Ground	GND	P1	P	GND	Ground
Power and Ground	GND	P6	P	GND	Ground
Power and Ground	GND	P8	P	GND	Ground
Power and Ground	GND	P10	P	GND	Ground
Power and Ground	GND	P12	P	GND	Ground
Power and Ground	GND	P13	P	GND	Ground
Power and Ground	GND	P14	P	GND	Ground
Power and Ground	VDDAH	G4	P	Supply	1.0 V power supply for host side analog
Power and Ground	VDDAH	G5	P	Supply	1.0 V power supply for host side analog
Power and Ground	VDDAH	J4	P	Supply	1.0 V power supply for host side analog
Power and Ground	VDDAH	J5	P	Supply	1.0 V power supply for host side analog
Power and Ground	VDDAL	F7	P	Supply	1.0 V power supply for line side analog

Power and Ground	VDDAL	G7	P	Supply	1.0 V power supply for line side analog
Power and Ground	VDDAL	G9	P	Supply	1.0 V power supply for line side analog
Power and Ground	VDDAL	H9	P	Supply	1.0 V power supply for line side analog
Power and Ground	VDDAL	J7	P	Supply	1.0 V power supply for line side analog
Power and Ground	VDDHSL	F9	P	Supply	1.2 V power supply for line side IOs
Power and Ground	VDDHSL	F10	P	Supply	1.2 V power supply for line side IOs
Power and Ground	VDDHSL	G10	P	Supply	1.2 V power supply for line side IOs
Power and Ground	VDDHSL	H10	P	Supply	1.2 V power supply for line side IOs
Power and Ground	VDDHSL	J9	P	Supply	1.2 V power supply for line side IOs
Power and Ground	VDDHSL	J10	P	Supply	1.2 V power supply for line side IOs
Power and Ground	VDDL	H4	P	Supply	1.0 V power supply for chip core
Power and Ground	VDDL	H5	P	Supply	1.0 V power supply for chip core
Power and Ground	VDDL	H7	P	Supply	1.0 V power supply for chip core
Power and Ground	VDDMDIO	C7	P	Supply	MDIO power supply
Power and Ground	VDDTTL	C9	P	Supply	LVTTTL power supply
Power and Ground	VDDTTL	M6	P	Supply	LVTTTL power supply
Receive and Transmit Path	LOPC0	D6	I	LVTTTL	Loss of optical carrier, channel 0. Internally pulled high.
Receive and Transmit Path	LOPC1	M7	I	LVTTTL	Loss of optical carrier, channel 1. Internally pulled high.
Receive and Transmit Path	RXIN0N	B13	I	CML	Receive channel 0 input data, complement
Receive and Transmit Path	RXIN0P	B14	I	CML	Receive channel 0 input data, true
Receive and Transmit Path	RXIN1N	L14	I	CML	Receive channel 1 input data, complement
Receive and Transmit Path	RXIN1P	L13	I	CML	Receive channel 1 input data, true
Receive and Transmit Path	TXOUT0N	D14	O	CML	Transmit channel 0 output data, complement
Receive and Transmit Path	TXOUT0P	D13	O	CML	Transmit channel 0 output data, true

Receive and Transmit Path	TXOUT1N	N13	O	CML	Transmit channel 1 output data, complement
Receive and Transmit Path	TXOUT1P	N14	O	CML	Transmit channel 1 output data, true
Reserved/No Connect	NC	D8			No connect
Reserved/No Connect	NC	E8			No connect
Reserved/No Connect	NC	K7			No connect
Reserved/No Connect	NC	L7			No connect
Reserved/No Connect	NC	L10			No connect
Reserved/No Connect	NC	M8			No connect (formerly labeled as ANATEST)
SPI	MISO	E11	O	LVTTTL	SPI slave data output
SPI	MOSI	E9	I	LVTTTL	SPI slave data input
SPI	SCK	D11	I	LVTTTL	SPI slave clock input
SPI	SSN	D9	I	LVTTTL	SPI slave chip select input
XAUI Channel	XRX0_0N	C2	I	CML	XAUI channel 0, Rx path lane 0, serial data input, complement
XAUI Channel	XRX0_0P	C1	I	CML	XAUI channel 0, Rx path lane 0, serial data input, true
XAUI Channel	XRX0_1N	D2	I	CML	XAUI channel 0, Rx path lane 1, serial data input, complement
XAUI Channel	XRX0_1P	D1	I	CML	XAUI channel 0, Rx path lane 1, serial data input, true
XAUI Channel	XRX0_2N	E2	I	CML	XAUI channel 0, Rx path lane 2, serial data input, complement
XAUI Channel	XRX0_2P	E1	I	CML	XAUI channel 0, Rx path lane 2, serial data input, true
XAUI Channel	XRX0_3N	F2	I	CML	XAUI channel 0, Rx path lane 3, serial data input, complement
XAUI Channel	XRX0_3P	F1	I	CML	XAUI channel 0, Rx path lane 3, serial data input, true
XAUI Channel	XRX1_0N	P2	I	CML	XAUI channel 1, Rx path lane 0, serial data input, complement
XAUI Channel	XRX1_0P	N2	I	CML	XAUI channel 1, Rx path lane 0, serial data input, true
XAUI Channel	XRX1_1N	P3	I	CML	XAUI channel 1, Rx path lane 1, serial data input, complement
XAUI Channel	XRX1_1P	N3	I	CML	XAUI channel 1, Rx path lane 1, serial data input, true
XAUI Channel	XRX1_2N	P4	I	CML	XAUI channel 1, Rx path lane 2, serial data input, complement

XAUI Channel	XRX1_2P	N4	I	CML	XAUI channel 1, Rx path lane 2, serial data input, true
XAUI Channel	XRX1_3N	P5	I	CML	XAUI channel 1, Rx path lane 3, serial data input, complement
XAUI Channel	XRX1_3P	N5	I	CML	XAUI channel 1, Rx path lane 3, serial data input, true
XAUI Channel	XTX0_0N	B6	O	CML	XAUI channel 0, Tx path lane 0, serial data output, complement
XAUI Channel	XTX0_0P	A6	O	CML	XAUI channel 0, Tx path lane 0, serial data output, true
XAUI Channel	XTX0_1N	B5	O	CML	XAUI channel 0, Tx path lane 1, serial data output, complement
XAUI Channel	XTX0_1P	A5	O	CML	XAUI channel 0, Tx path lane 1, serial data output, true
XAUI Channel	XTX0_2N	B4	O	CML	XAUI channel 0, Tx path lane 2, serial data output, complement
XAUI Channel	XTX0_2P	A4	O	CML	XAUI channel 0, Tx path lane 2, serial data output, true
XAUI Channel	XTX0_3N	B3	O	CML	XAUI channel 0, Tx path lane 3, serial data output, complement
XAUI Channel	XTX0_3P	A3	O	CML	XAUI channel 0, Tx path lane 3, serial data output, true
XAUI Channel	XTX1_0N	H2	O	CML	XAUI channel 1, Tx path lane 0, serial data output, complement
XAUI Channel	XTX1_0P	H1	O	CML	XAUI channel 1, Tx path lane 0, serial data output, true
XAUI Channel	XTX1_1N	J2	O	CML	XAUI channel 1, Tx path lane 1, serial data output, complement
XAUI Channel	XTX1_1P	J1	O	CML	XAUI channel 1, Tx path lane 1, serial data output, true
XAUI Channel	XTX1_2N	K2	O	CML	XAUI channel 1, Tx path lane 2, serial data output, complement
XAUI Channel	XTX1_2P	K1	O	CML	XAUI channel 1, Tx path lane 2, serial data output, true
XAUI Channel	XTX1_3N	L2	O	CML	XAUI channel 1, Tx path lane 3, serial data output, complement
XAUI Channel	XTX1_3P	L1	O	CML	XAUI channel 1, Tx path lane 3, serial data output, true

7 Package Information

The VSC8489YJU-02 package is a lead-free (Pb-free), 196-pin, flip chip ball grid array (FCBGA) with a 15 mm × 15 mm body size, 1 mm pin pitch, and 1.4 mm maximum height.

Lead-free products from Microsemi comply with the temperatures and profiles defined in the joint IPC and JEDEC standard IPC/JEDEC J-STD-020. For more information, see the IPC and JEDEC standard.

This section provides the package drawing, thermal specifications, and moisture sensitivity rating for the VSC8489-02 device.

7.1 Package Drawing

The following illustration shows the package drawing for the VSC8489-02 device. The drawing contains the top view, bottom view, side view, dimensions, tolerances, and notes.

Figure 46 • Package Drawing

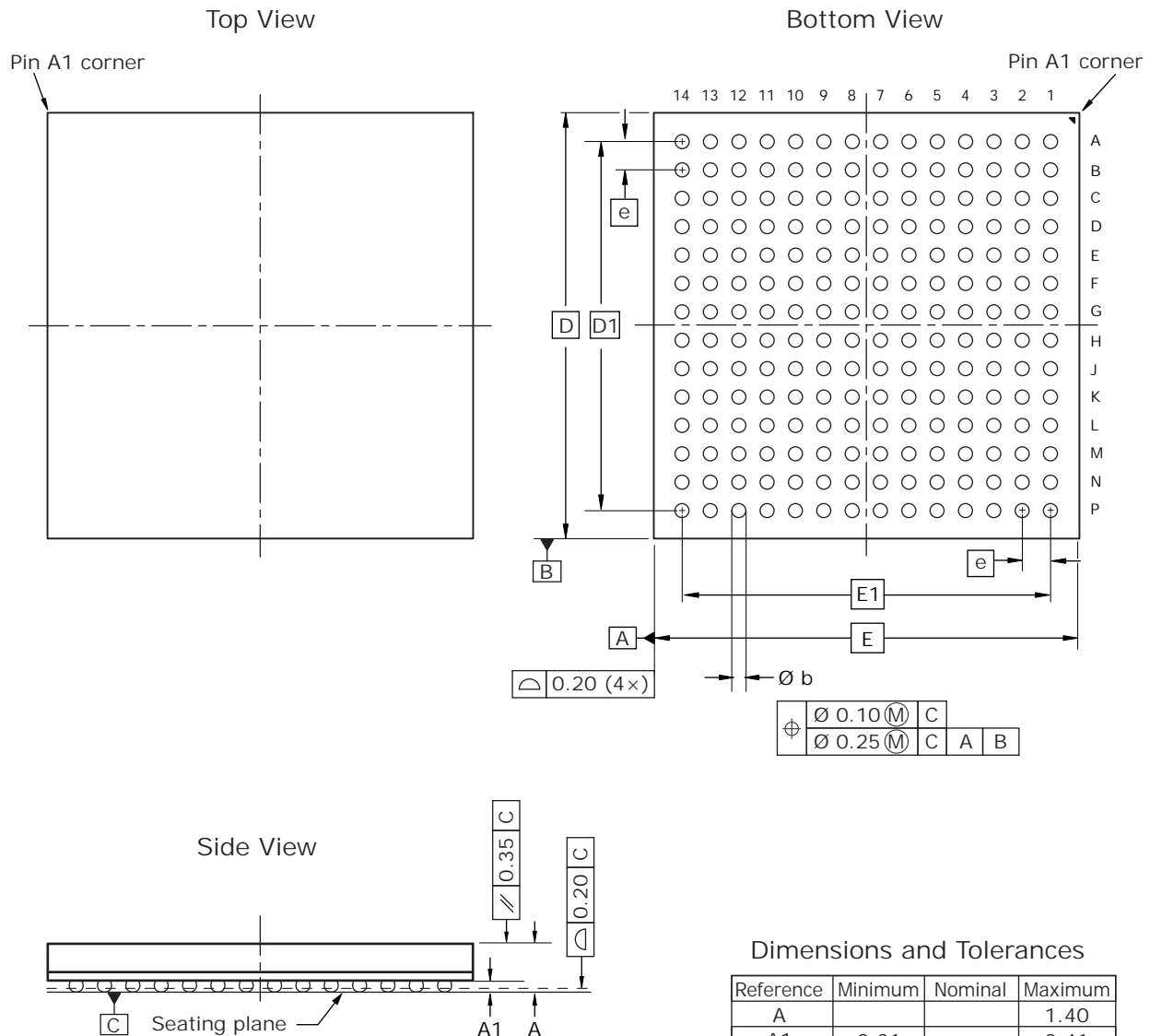

Notes

1. All dimensions and tolerances are in millimeters (mm).
2. Radial true position is represented by typical values.

7.2 Thermal Specifications

Thermal specifications for this device are based on the JEDEC JESD51 family of documents. These documents are available on the JEDEC Web site at www.jedec.org. The thermal specifications are modeled using a four-layer test board with two signal layers, a power plane, and a ground plane (2s2p

PCB). For more information about the thermal measurement method used for this device, see the JESD51-1 standard.

Table 56 • Thermal Resistances

Symbol	°C/W	Parameter
θ_{JCTop}	3.35	Die junction to package case top
θ_{JB}	13.3	Die junction to printed circuit board
θ_{JA}	22.74	Die junction to ambient
θ_{JMA} at 1 m/s	18.6	Die junction to moving air measured at an air speed of 1 m/s
θ_{JMA} at 2 m/s	17.03	Die junction to moving air measured at an air speed of 2 m/s

To achieve results similar to the modeled thermal measurements, the guidelines for board design described in the JESD51 family of publications must be applied. For information about applications using FCBGA packages, see the following:

- JESD51-2A, *Integrated Circuits Thermal Test Method Environmental Conditions, Natural Convection (Still Air)*
- JESD51-6, *Integrated Circuit Thermal Test Method Environmental Conditions, Forced Convection (Moving Air)*
- JESD51-8, *Integrated Circuit Thermal Test Method Environmental Conditions, Junction-to-Board*
- JESD51-9, *Test Boards for Area Array Surface Mount Package Thermal Measurements*

7.3 Moisture Sensitivity

This device is rated moisture sensitivity level 4 as specified in the joint IPC and JEDEC standard IPC/JEDEC J-STD-020. For more information, see the IPC and JEDEC standard.

8 Design Considerations

This section provides information about design considerations for the VSC8489-02 device.

8.1 Low-power mode and SerDes calibration

SerDes re-initialization and re-calibration is required when the PHY comes out of the low power mode.

Use the API to enable the required low power and re-calibration functionality instead of the low power enabling bits at 1x0000.11, 2x0000.11, 3x0000.11, or 4x0000.11, which force a reset of the SerDes registers.

8.2 Low-power mode should not be enabled when failover switching is enabled

The device design was not intended to support the low power mode of operation when the failover switch is enabled. When low power mode is enabled in one channel, the data flow of the other channel could be adversely affected if the failover switch is enabled, leading to data errors.

Do not enable the low power mode when the failover switch is enabled.

8.3 Flow control with failover switching

Both Tx and Rx data paths of the channel have to be switched at the same time when flow control is enabled. The Tx data path of one channel in one direction and the Rx data path of another channel in the opposite direction cannot be mixed.

8.4 XAUI BIST Checker Compatibility

The XAUI BIST checker fails when checking the mixed frequency test pattern. This mixed frequency test pattern is optional in the IEEE802.3ae specifications.

8.5 SPI bus speeds

The maximum speed enabled on the 4-pin slave SPI bus is 15.4 MHz in normal mode and 30 MHz in fast mode. The maximum speed for the 3-pin push out only SPI is 40 MHz.

8.6 GPIO as TOSI

A small value pull-up is needed when a GPIO pin is used as TOSI. For more information, contact your Microsemi representative.

8.7 10GBASE-KR auto negotiation and training

10GBASE-KR negotiation and training (IEEE802.3 Clause 72 and Clause 73) is only available for 10G. It is not available for 1G.

8.8 Loopbacks in 10G WAN mode

Loopbacks L1, L2, and L2C are not available in 10G WAN mode if jumbo frames are used.

8.9 10/100M mode not supported

The PHY does not support modes of 10/100M in CuSFP. The autoneg feature is only supported in 100BASE-X mode but not in SGMII mode. When interfacing with 1G SGMII mode (such as with CuSFP), the autoneg feature has to be turned off.

8.10 Limited access to registers during failover cross-connect mode

The following register bits should not be used if failover cross-connect is enabled (that is, if PMA0 is connected to channel_1 and PMA1 I connected to channel_0).

- 1x0001.2
- 1x0008.10
- 1x000A.0
- 1x9003.4
- 1x0008.11
- 1x9004.4

8.11 Limited auto negotiation support in 1G mode

In 1G mode, the device is specified to support basic auto negotiation for 1000BASE-X (optical interface) only. For an SGMII interface employed in interfacing CuSFP, auto negotiation is not supported. Otherwise, auto negotiation must be disabled on both the device and the CuSFP in order to have the data link be established.

8.12 Limited 1G status reporting

In 1G mode, the 1G status signal from the 1G PCS block is driven by a sticky bit rather than a latched bit, and so is useful only for link down (and not useful for link up conditions). Also, in 1000BASE-X mode, the link up indicator does not include AN done status.

8.13 RXCKOUT squelching

RXCKOUT (positive and negative) can be squelched by varying link status (LOPC, PCS_Fault) in the device through the use of the API.

9 Ordering Information

The VSC8489YJU-02 package is a lead-free (Pb-free), 196-pin, flip chip ball grid array (FCBGA) with a 15 mm × 15 mm body size, 1 mm pin pitch, and 1.4 mm maximum height.

Lead-free products from Microsemi comply with the temperatures and profiles defined in the joint IPC and JEDEC standard IPC/JEDEC J-STD-020. For more information, see the IPC and JEDEC standard.

The following table lists the ordering information for the VSC8489-02 device.

Table 57 • Ordering Information

Part Order Number	Description
VSC8489YJU-02	Lead-free, 196-pin FCBGA with a 15 mm × 15 mm body size, 1 mm pin pitch, and 1.4 mm maximum height.

Looking for pricing, stock, or lifecycle information?

Click below to explore more details on WIN SOURCE:

- ⊖ [View VSC8489YJU-02 on WIN SOURCE](#)
- ⊖ [Microchip Technology](#) Information

Optimize Your Supply Chain with WIN SOURCE Solutions

- ✓ Global Sourcing Solution
- ✓ Obsolete Management
- ✓ Cost Control Management
- ✓ Shortage Management
- ✓ Alternative Solution
- ✓ Excess Inventory Management