



**THE DATASHEET OF  
FPF2260ATMX**



# 28 V Rated OVLO/UVLO Controller with Negative Stress Protection



ON Semiconductor®

[www.onsemi.com](http://www.onsemi.com)

## FPF2260ATMX

### Description

FPF2260ATMX is an OVP and UVLO controller with reverse / negative voltage protection. The device controls and drives a pair of external N-MOSFET that can operate over an input voltage range of 2.8 V to 23 V. In that way, with OVP feature implemented, the system can allow huge current as long as the external MOSFET can handle.

When the input voltage exceeds the over-voltage threshold or lower than under-voltage threshold, the external FET is turned off immediately to prevent damage to the protected downstream components.

When the input voltage is stressed a negative voltage, the external FET will also be turned off and prevent OUT dropping to negative voltage.

FPF2260ATMX is available in a small X2QFN12 package and operate over the free-air temperature range of -40°C to +85°C.

### Features

- Over-voltage Protection Up to ±28V
- Programmable Over-voltage Lockout (OVLO)
  - ◆ Externally Adjustable via OVLO Pin
  - ◆ Default OVLO Level without Additional Components
- Programmable Under-voltage Lockout (UVLO)
  - ◆ Externally Adjustable via UVLO Pin
- Active-high Enable Pin (EN) for Device
- Super-fast OVLO Response Time: Typical 150 ns
- Negative Voltage Blocking
- Short Circuit Protection and Auto-restart
- Selectable Gate Driver Voltage
- USB OTG Support Mode
- Open-Drain Output Indicators
  - ◆ OVFLGB for Over Voltage Stress
  - ◆ UVFLAG for Under Voltage Lockout
- Robust ESD Performance
  - ◆ 2 kV Human Body Model (HBM)
  - ◆ 1 kV Charged Device Model (CDM)

### Typical Applications

- Mobile Phones
- PDAs
- Notebooks
- Desktops

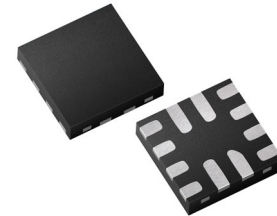

X2QFN12 1.6x1.6, 0.4P  
CASE 722AG

### MARKING DIAGRAM

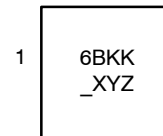

6B = Specific Device Code  
 KK = 2-Digits Lot Run Traceability Code  
 \_ = Pin 1 Identifier  
 XY = 2-Digit Date Code  
 Z = Assembly Pant Code

### PIN CONNECTIONS

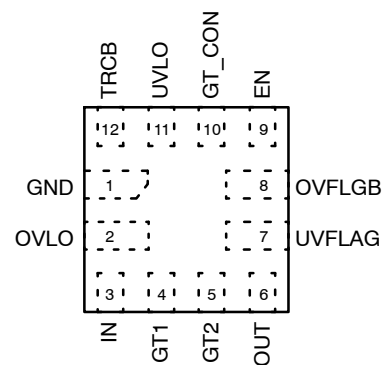

(Top View)

### ORDERING INFORMATION

See detailed ordering and shipping information on page 7 of this data sheet.

# FPF2260ATMX

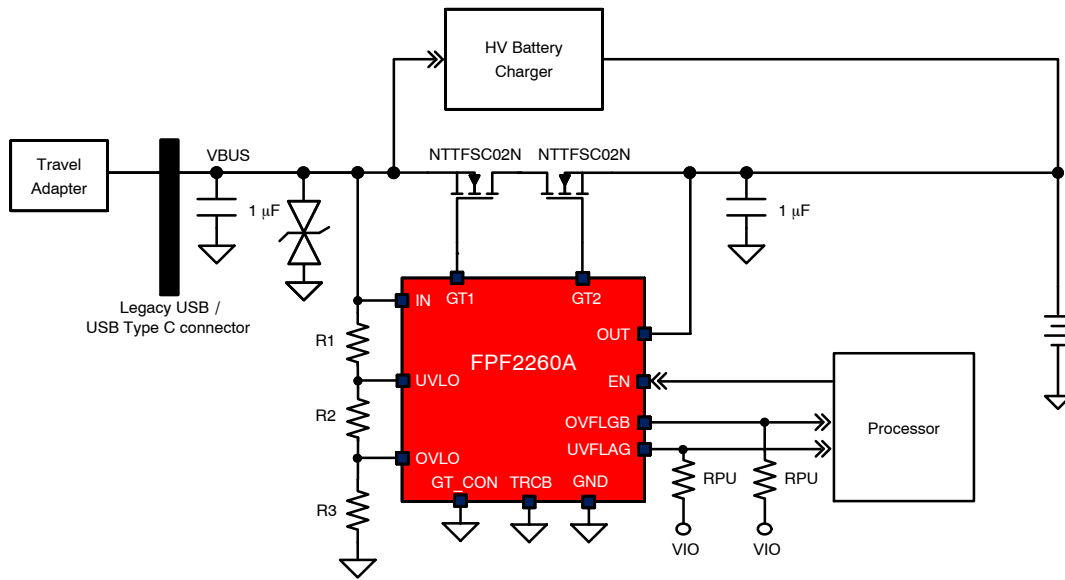

Figure 1. Schematic – Adjustable Option

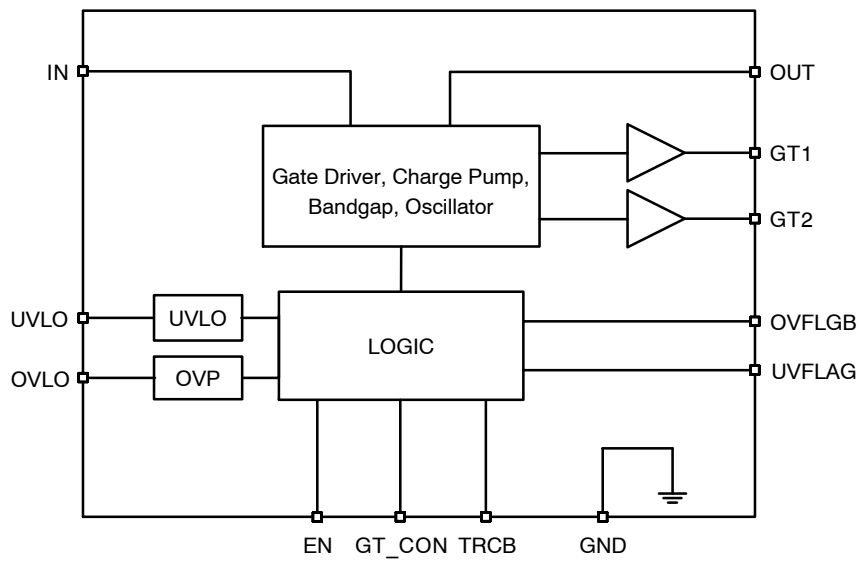

Figure 2. Simplified Block Diagram

# FPF2260ATMX

## PIN FUNCTION DESCRIPTION

Pin No.	Name	Description
1	GND	Ground
2	OVLO	OVLO Input: Over Voltage Lockout Adjustment Input
3	IN	Power Input: External FET Input and Device Supply
4	GT1	Gate 1 Output:
5	GT2	Gate 2 Output:
6	OUT	Power Output: External FET Output and Device Supply(More Description)
7	UVFLAG	UVLO Flag Output: Open-drain output, turn ON the internal MOS to pull down this pin to indicate no Under-Voltage condition on IN
8	OVFLGB	OVP Flag Output: Open-drain output, turn ON the internal MOS to pull down this pin to indicate Over-Voltage condition on IN
9	EN	Enable Input: Active HIGH with internal 500 kΩ pull down resistor
10	GT_CON	Gate Voltage Control Input: VGS select Pin 0: Vgs = 12 V; 1/floating: Vgs = 6V with internal 500 kΩ pull up resistor
11	UVLO	UVLO Input: Under Voltage Lockout Adjustment Input
12	TRCB	True RCB Enable Input: 0: no TRCB; 1/floating: Block Reverse Current Entirely with internal 500 kΩ pull up resistor

## MAXIMUM RATINGS

Symbol	Parameter	Value	Unit
V <sub>IN</sub>	Input Voltage Range (Note 1)	-28 to +28	V
V <sub>OUT</sub>	Output Voltage Range	-0.3 to +28	V
V <sub>I/O</sub>	Standard I/O Range (UVFLAG, OVFLGB, TRCB, GT_CON)	-0.3 to +6	V
V <sub>HVIO</sub>	HV I/O Range (OVLO, UVLO, EN)	-0.3 to +28	V
T <sub>J(max)</sub>	Maximum Junction Temperature	150	°C
TSTG	Storage Temperature Range	-65 to 150	°C
ESDHBM	ESD Capability, Human Body Model (Note 2)	±2	kV
ESDCDM	ESD Capability, Charged Device Model (Note 2)	±1	kV
T <sub>SLD</sub>	Lead Temperature Soldering Reflow (SMD Styles Only), Pb-Free Versions (Note 3)	260	°C

Stresses exceeding those listed in the Maximum Ratings table may damage the device. If any of these limits are exceeded, device functionality should not be assumed, damage may occur and reliability may be affected.

1. Refer to ELECTRICAL CHARACTERISTICS, RECOMMENDED OPERATING RANGES and/or APPLICATION INFORMATION for Safe Operating parameters.
2. This device series incorporates ESD protection and is tested by the following methods:  
 ESD Human Body Model tested per AEC-Q100-002 (EIA/JESD22-A114)  
 ESD Charged Device Model tested per AEC-Q100-011 (EIA/JESD22-C101)  
 Latch-up Current Maximum Rating: ≤ 150 mA per JEDEC standard: JESD78
3. For information, please refer to our Soldering and Mounting Techniques Reference Manual, SOLDERRM/D

## THERMAL CHARACTERISTICS

Symbol	Rating	Value	Unit
R <sub>θJA</sub>	Thermal Characteristics, X2QFN12 (Note 4) Thermal Resistance, Junction-to-Air (Note 5)	139.3	°C/W

4. Refer to ELECTRICAL CHARACTERISTICS, RECOMMENDED OPERATING RANGES and/or APPLICATION INFORMATION for Safe Operating parameters.
5. Values based on 2S2P JEDEC std. PCB.

# FPF2260ATMX

## RECOMMENDED OPERATING CONDITIONS

Symbol	Parameter	Min	Max	Unit
$V_{in}$	Supply Voltage on VIN (GT_CON floating)	4.0	22	V
	Supply Voltage on VIN (GT_CON grounded)		16	
$V_{OVLO}$ , $UVLO$ , $EN$ , $TRCB$ , $GT\_CON$ , $OVFLAG$ , $UVFLAG$	I/O pins	0	5.5	V
$C_{in}$	IN Capacitor	1	–	$\mu F$
$C_{out}$	OUT Capacitor	1	–	$\mu F$
$T_A$	Ambient Temperature	–40	85	$^{\circ}C$

Functional operation above the stresses listed in the Recommended Operating Ranges is not implied. Extended exposure to stresses beyond the Recommended Operating Ranges limits may affect device reliability.

**ELECTRICAL CHARACTERISTICS** ( $V_{IN} = 2.9$  to  $23$  V,  $C_{IN} = 0.1$   $\mu F$ ,  $C_{OUT} = 0.1$   $\mu F$ ,  $T_A = -40$  to  $85^{\circ}C$ ; For typical values  $V_{IN} = 5.0$  V,  $I_{IN} \leq 3$  A,  $C_{IN} = 0.1$   $\mu F$ ,  $T_A = 25^{\circ}C$ , for min/max values  $T_A = -40^{\circ}C$  to  $85^{\circ}C$ ; unless otherwise noted. (Note 6)

Symbol	Parameter	Test Condition	Min	Typ	Max	Unit
--------	-----------	----------------	-----	-----	-----	------

### LEAKAGE AND QUIESCENT CURRENTS

$I_Q$	Input Quiescent Current on VIN	$V_{IN} = 5$ V, $V_{OVLO} = 1$ V, $TRCB = 0$ , $V_{OUT}$ floating	–	160	–	$\mu A$
		$V_{IN} = 20$ V, $V_{OVLO} = 1$ V, $TRCB = 0$ , $V_{OUT}$ floating	–	400	–	
$I_{OFF}$	Device turned off current	$V_{IN} = 5$ V, $V_{EN} = 0$ V, $V_{OUT} = 0$ V	–	120	–	$\mu A$
$I_{IN\_Q}$	Supply Current during Over Voltage	$V_{IN} = 20$ V, $V_{OVLO} = 1.8$ V, $V_{OUT} = 0$ V	–	180	–	$\mu A$
$I_{OVLO}$	OVLO Input Leakage Current	$V_{OVLO} = V_{OVLO\_TH}$	–100	–	100	nA

### OVER VOLTAGE AND UNDER VOLTAGE LOCKOUT

$V_{DEF\_OVLO}$	Default Over-Voltage Trip Level	$V_{IN}$ rising, $T_A = -40$ to $85^{\circ}C$	5.9	6.1	6.3	V
$V_{DEF\_UVLO}$	Default Under-Voltage Trip Level	$V_{IN}$ falling, $T_A = -40$ to $85^{\circ}C$	1.8	2.0	2.2	V
$V_{OVLO\_TH}$	OVLO set threshold	$V_{OVLO}$ rising from 1.1 V to 1.3 V, the OVLO voltage to switch off power FET	1.15	1.19	1.23	V
$V_{HYS\_OVLO}$	OVLO threshold hysteresis		–	2	–	%
$V_{UVLO\_TH}$	UVLO set threshold	$V_{UVLO}$ falling from 1.3 V to 1.1 V, the UVLO voltage to switch off power FET	1.15	1.17	1.23	V
$V_{HYS\_UVLO}$	UVLO threshold hysteresis		–	2	–	%
$V_{OV\_RNG}$	Adjustable OVLO range	$V_{OVLO} > 0.5$ V	4	–	22	V

### TRCB (IN TRCB MODE ONLY, I.E. VTRCB = HIGH/FLOAT)

$V_{DROP}$	TRCB trigger level	$V_{IN} = 5$ V, $I_{LOAD} = 100$ mA	–	35	–	mV
$t_{REL}$	TRCB release time	$V_{IN} = 5$ V	–	1	–	ms

### I/O THRESHOLDS

$V_{IH\_OVLO}$ $V_{IL\_OVLO}$	OVLO Input Threshold Voltage	High Low	0.3 –	– –	0.15	V V
	Voltage Increasing, Logic High Voltage Decreasing, Logic Low					

### GATE DRIVER

$V_{GS}$	Turn on status gate positive voltage over OUT (Note 8)	$V_{IN} = V_{OUT} = 5$ V, $V_{GT\_CON} = 0$ V	–	12	–	V
		$V_{IN} = V_{OUT} = 5$ V, $V_{GT\_CON} = 1.8$ V	–	6	–	
$I_{GS}$	Turn on status gate positive current	$V_{TRCB} = 0$ V, $V_{IN} = V_{OUT} = 5$ V, $V_{GT\_CON} = 1.8$ V, $I_{LOAD} = 10$ mA	–	–	10	$\mu A$
	OVP turn off gate current (Note 9)	$V_{IN} = 5$ V, $V_{GT\_CON} = 1.8$ V, $V_{OVLO}$ from 1.1 V to 1.3 V	–	–	3	A

# FPF2260ATMX

**ELECTRICAL CHARACTERISTICS** ( $V_{IN} = 2.9$  to  $23$  V,  $C_{IN} = 0.1$   $\mu$ F,  $C_{OUT} = 0.1$   $\mu$ F,  $T_A = -40$  to  $85^\circ$ C; For typical values  $V_{IN} = 5.0$  V,  $I_{IN} \leq 3$  A,  $C_{IN} = 0.1$   $\mu$ F,  $T_A = 25^\circ$ C, for min/max values  $T_A = -40^\circ$ C to  $85^\circ$ C; unless otherwise noted. (Note 6) (continued)

Symbol	Parameter	Test Condition	Min	Typ	Max	Unit
--------	-----------	----------------	-----	-----	-----	------

## I/O AND LOGIC CONTROL

$V_{IH}$	I/O Logic High Voltage	Pins: EN, TRCB, GT_CON	1.2	-	-	V
$V_{IL}$	I/O Logic Low Voltage		-	-	0.5	V
$V_{OL}$	Output Low Voltage of Open-Drain pins	$V_{I/O} = 3.3$ V, $I_{SINK} = 1$ mA, Pins: UVFLAG, OVFLGB	-	-	0.4	V
$I_{LKG}$	Leakage Current of I/O pins	$V_{I/O} = 3.3$ V, Logic de-asserted, Pins: UVFLAG, OVFLGB, GT_CON	-0.5	-	0.5	$\mu$ A

## TIMING

$t_{SW\_DEB}$	De-bounce Time of Power FET turned on	Time from $2.5$ V $< V_{IN} < V_{IN\_OVLO}$ to $V_{OUT} = 0.1 \times V_{IN}$	-	15	-	ms
$t_{OTG\_DEB}$	De-bounce Time of OTG turned on	Time from $V_{OUT} > 2.8$ V to $V_{IN} = 0.1 \times V_{OUT}$	-	15	-	ms
$t_{UV\_DEB}$	De-bounce Time of UVFLAG flag	Time from $V_{IN} > V_{IN\_UVLO}$ to UVFLAG $< 0.4$ V	-	130	-	$\mu$ s
$t_{OV\_DEB}$	De-bounce Time of OVFLGB flag	Time from $V_{IN} < V_{IN\_OVLO}$ to OVFLGB $> 1.8$ V	-	1	-	ms
$t_R$	Switch Turn-On rising Time (Note 9)	$V_{IN} = 5$ V, $R_L = 100$ $\Omega$ , $C_L = 22$ $\mu$ F, $V_{OUT}$ from $0.1 \times V_{IN}$ to $0.9 \times V_{IN}$	-	2	-	ms
$t_{OFF}$	Switch Turn-Off Time (Note 8, 9)	$R_L = 10$ $\Omega$ , $C_L = 0$ $\mu$ F, time from $V_{IN} > V_{OVLO}$ to $V_{OUT} = 0.9 \times V_{IN}$ Internal OVP level External OVP level (Note 10)	-	50	-	ns
			-	100	-	ns

Product parametric performance is indicated in the Electrical Characteristics for the listed test conditions, unless otherwise noted. Product performance may not be indicated by the Electrical Characteristics if operated under different conditions.

6. Performance guaranteed over the indicated operating temperature range by design and/or characterization tested at  $T_J = T_A = 25^\circ$ C. Low duty cycle pulse techniques are used during testing to maintain the junction temperature as close to ambient as possible.

7. Refer to the APPLICATION INFORMATION section.

8. Based on the recommended MOSFET devices.

9. Values based on design and/or characterization

10. Depends on the capacitance on OVLO pin.

# FPF2260ATMX

## TYPICAL CHARACTERISTICS

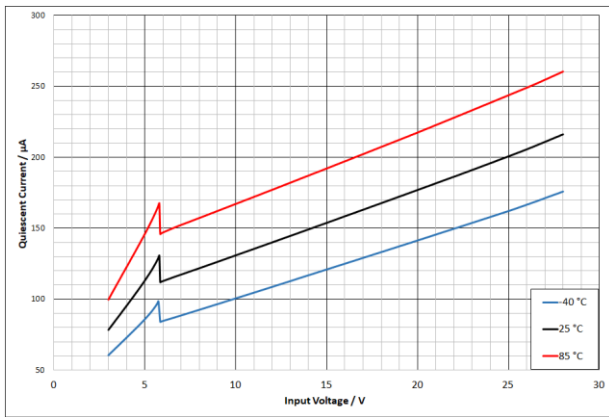

Figure 3. Quiescent Current over Temperature

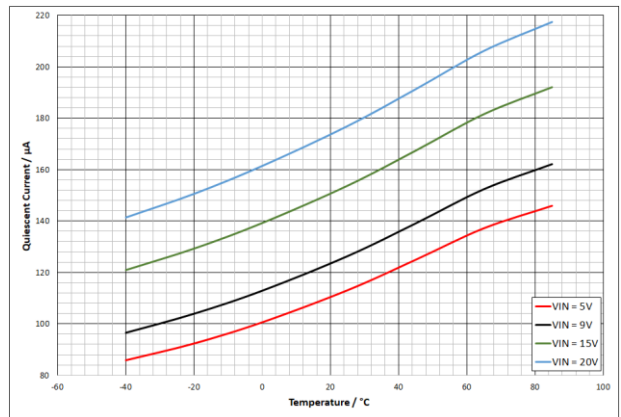

Figure 4. Quiescent Current over  $V_{IN}$

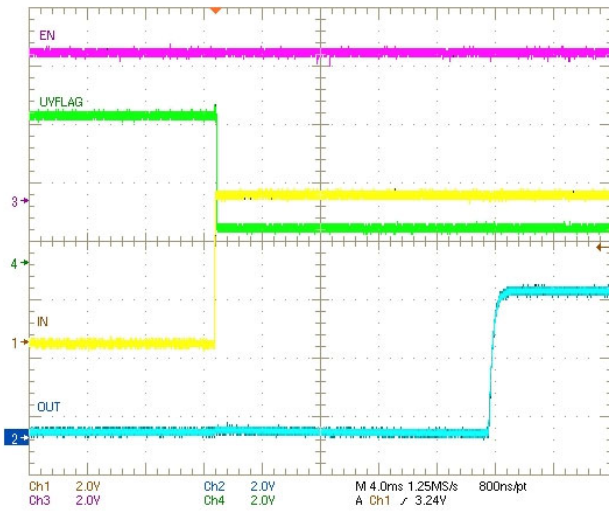

Figure 5. Power-Up Transient  
( $V_{IN} = 5\text{ V}$ ,  $C_{OUT} = 0.1\ \mu\text{F}$ )

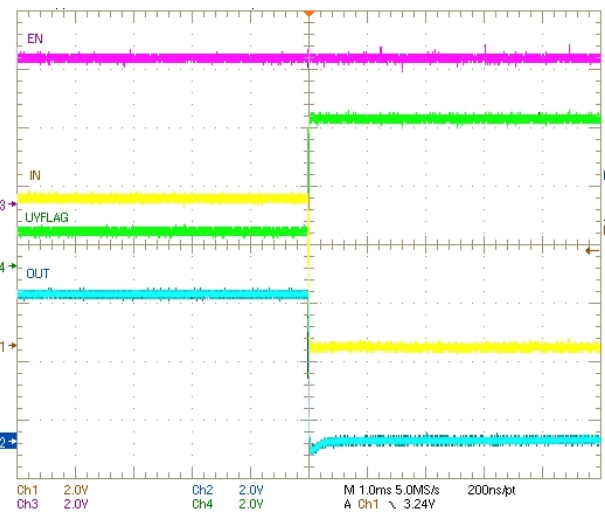

Figure 6. Power-Down Transient  
( $V_{IN} = 5\text{ V}$ ,  $C_{OUT} = 0.1\ \mu\text{F}$ )

# FPF2260ATMX

## FUNCTION DESCRIPTION

### General

FPF2260A is an OVP controller to drive external N-type MOSFETs. The device can protect next stage system which is optimized to lower voltage working condition, especially with ultra-high charging current. The device includes multi-functions including OVP, Advanced TRCB, and Negative Stress protection.

### Power MOSFET Driver

The FPF2260A integrates charge pump driver to control external N-type MOSFET pair. The drive voltage can be configured by GPIO for different MOSFET.

The drive voltage for MOSFET can be configured by GPIO pin GT\_CON.  $V_{GS}$  could be set to 6 V by pull GT\_CON to high or floating. Or,  $V_{GS}$  will be set to 12 V by pulling GT\_CON to ground.

### True Reverse Current Blocking and USB OTG

The FPF2260A support advanced TRCB mode by pulling TRCB pin to high or floating it. In the advanced TRCB mode, no reverse current will be seen from OUT to IN through the external MOSFETs if  $V_{OUT} - V_{IN} > 30$  mV.

When advanced TRCB mode is active, OTG operation is not supported. If OTG is needed, TRCB pin needs to be pulled down to ground.

### Enable Control

The GPIO EN is an active high control pin. When the voltage is pulled low, FPF2260A will disable the external MOSFETs by connecting GT1 to IN and GT2 to OUT.

When EN is logic high, FPF2260A will close external MOSFET if there are no over stressed condition.

### Under Voltage Lockout

FPF2260A will turn the FETs off when the voltage on IN is lower than the UVLO threshold  $V_{IN\_UVLO}$ .

Whenever IN voltage ramps up to higher than the threshold, the power FET will be turned on automatically after  $t_{DEB}$  de-bounce time if there is no other over stressed condition.

The external resistor ladder can be decided according to the following equation:

$$V_{IN\_UVLO} = V_{UVLO\_TH} \times [1 + R1 / (R2 + R3)] \quad (\text{eq. 1})$$

where R1, R2 and R3 are the resistors in figure 1.

### Over Voltage Lockout

The power FET will be turned off whenever IN voltage higher than  $V_{IN\_OVLO}$ . The value of  $V_{IN\_OVLO}$  can be set by external resistor ladder or just be default value  $V_{IN\_OVLO}$ .

When  $V_{OVLO} \leq 0.3$  V,  $V_{OVLO}$  is decided by default value. When  $V_{OVLO} > 0.3$  V, the power switch will be turned off once  $V_{OVLO} > V_{OVLO\_TH}$ . The external resistor ladder can be decided according to the following equation:

$$V_{IN\_OVLO} = V_{OVLO\_TH} \times [1 + (R1 + R2) / R3] \quad (\text{eq. 2})$$

where R1, R2 and R3 are the resistors in figure 1.

### Negative Voltage Protection

FPF2260 support negative voltage protection to help system avoid unexpected negative stress. The gate of first external power FET, GT1, will be pulled down with the voltage on IN when it is negative. This behavior can keep the external FET at off status till  $-28$  V.

## APPLICATIONS INFORMATION

### Input Decoupling ( $C_{in}$ )

A ceramic or tantalum at least 0.1  $\mu$ F capacitor is recommended and should be put before and close the connection point of MOSFET and FPF2260A IN. Higher capacitance and lower ESR will improve the overall line and load transient response.

### Output Decoupling ( $C_{out}$ )

The FPF2260A is a stable component and does not require a minimum Equivalent Series Resistance (ESR) for the output capacitor. The minimum output decoupling value is 0.1  $\mu$ F and can be augmented to fulfill stringent load transient requirements.

### Hints for PCB Layout

The external MOSFET is an important part to FPF2260A. The connection of gate should be as short as possible to avoid parasitic resistance and inductance for better OVP performance.

## ORDERING INFORMATION

Part Number	Marking	Package	Shipping <sup>†</sup>
FPF2260ATMX	6B	X2QFN12	5000 / Tape & Reel

<sup>†</sup>For information on tape and reel specifications, including part orientation and tape sizes, please refer to our Tape and Reel Packaging Specifications Brochure, BRD8011/D.

**X2QFN12 1.6x1.6, 0.4P**  
**CASE 722AG**  
**ISSUE A**

DATE 26 SEP 2017

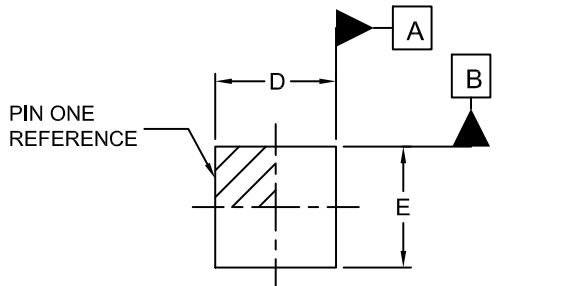

**TOP VIEW**

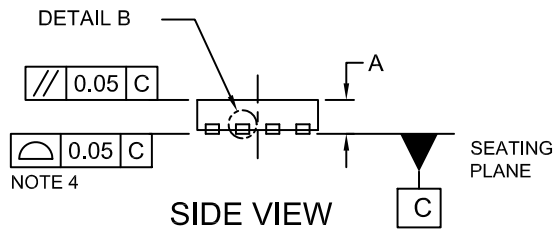

**SIDE VIEW**

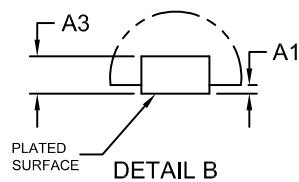

**DETAIL B**

**NOTES:**

1. DIMENSIONING AND TOLERANCING PER ASME Y14.5M, 2009.
2. CONTROLLING DIMENSION: MILLIMETERS
3. DIMENSION b APPLIES TO THE PLATED TERMINALS AND IS MEASURED BETWEEN 0.10 AND 0.20mm FROM THE TERMINAL TIP.
4. PROFILE APPLIES TO THE EXPOSED PAD AS WELL AS THE TERMINALS.

DIM	MILLIMETERS		
	MIN.	NOM.	MAX.
A	0.34	0.37	0.40
A1	--	--	0.05
A3	0.127 REF		
b	0.15	0.175	0.20
D	1.55	1.60	1.65
E	1.55	1.60	1.65
e	0.40 BSC		
L	0.25	0.30	0.35
L2	0.45	0.50	0.55

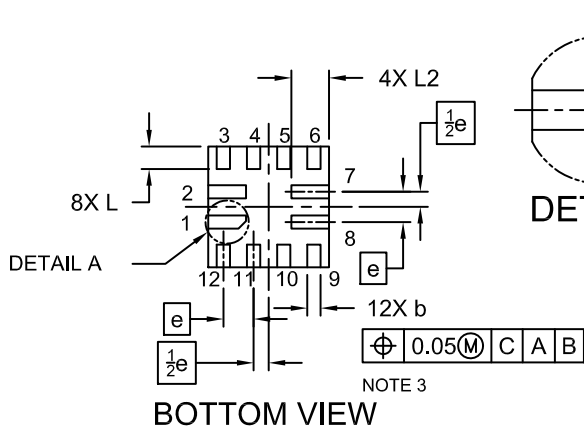

**BOTTOM VIEW**

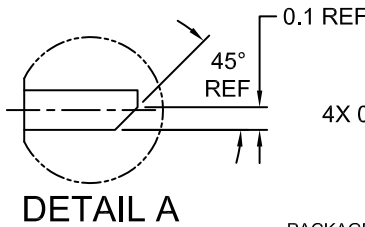

**DETAIL A**

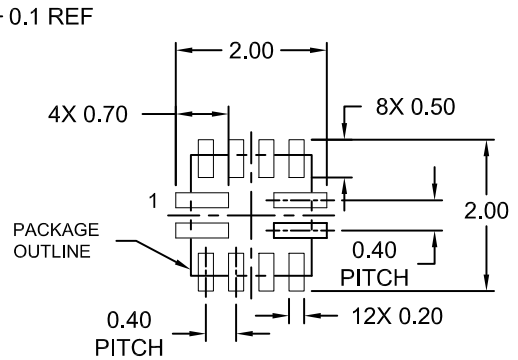

**RECOMMENDED MOUNTING FOOTPRINT**

<b>DOCUMENT NUMBER:</b>	<b>98AON13772G</b>	Electronic versions are uncontrolled except when accessed directly from the Document Repository. Printed versions are uncontrolled except when stamped "CONTROLLED COPY" in red.
<b>DESCRIPTION:</b>	<b>X2QFN12 1.6x1.6, 0.4P</b>	<b>PAGE 1 OF 1</b>

ON Semiconductor and are trademarks of Semiconductor Components Industries, LLC dba ON Semiconductor or its subsidiaries in the United States and/or other countries. ON Semiconductor reserves the right to make changes without further notice to any products herein. ON Semiconductor makes no warranty, representation or guarantee regarding the suitability of its products for any particular purpose, nor does ON Semiconductor assume any liability arising out of the application or use of any product or circuit, and specifically disclaims any and all liability, including without limitation special, consequential or incidental damages. ON Semiconductor does not convey any license under its patent rights nor the rights of others.

**onsemi**, **Onsemi**, and other names, marks, and brands are registered and/or common law trademarks of Semiconductor Components Industries, LLC dba "**onsemi**" or its affiliates and/or subsidiaries in the United States and/or other countries. **onsemi** owns the rights to a number of patents, trademarks, copyrights, trade secrets, and other intellectual property. A listing of **onsemi**'s product/patent coverage may be accessed at [www.onsemi.com/site/pdf/Patent-Marking.pdf](http://www.onsemi.com/site/pdf/Patent-Marking.pdf). **onsemi** reserves the right to make changes at any time to any products or information herein, without notice. The information herein is provided "as-is" and **onsemi** makes no warranty, representation or guarantee regarding the accuracy of the information, product features, availability, functionality, or suitability of its products for any particular purpose, nor does **onsemi** assume any liability arising out of the application or use of any product or circuit, and specifically disclaims any and all liability, including without limitation special, consequential or incidental damages. Buyer is responsible for its products and applications using **onsemi** products, including compliance with all laws, regulations and safety requirements or standards, regardless of any support or applications information provided by **onsemi**. "Typical" parameters which may be provided in **onsemi** data sheets and/or specifications can and do vary in different applications and actual performance may vary over time. All operating parameters, including "Typicals" must be validated for each customer application by customer's technical experts. **onsemi** does not convey any license under any of its intellectual property rights nor the rights of others. **onsemi** products are not designed, intended, or authorized for use as a critical component in life support systems or any FDA Class 3 medical devices or medical devices with a same or similar classification in a foreign jurisdiction or any devices intended for implantation in the human body. Should Buyer purchase or use **onsemi** products for any such unintended or unauthorized application, Buyer shall indemnify and hold **onsemi** and its officers, employees, subsidiaries, affiliates, and distributors harmless against all claims, costs, damages, and expenses, and reasonable attorney fees arising out of, directly or indirectly, any claim of personal injury or death associated with such unintended or unauthorized use, even if such claim alleges that **onsemi** was negligent regarding the design or manufacture of the part. **onsemi** is an Equal Opportunity/Affirmative Action Employer. This literature is subject to all applicable copyright laws and is not for resale in any manner.

## ADDITIONAL INFORMATION

### TECHNICAL PUBLICATIONS:

Technical Library: [www.onsemi.com/design/resources/technical-documentation](http://www.onsemi.com/design/resources/technical-documentation)  
onsemi Website: [www.onsemi.com](http://www.onsemi.com)

### ONLINE SUPPORT: [www.onsemi.com/support](http://www.onsemi.com/support)

For additional information, please contact your local Sales Representative at [www.onsemi.com/support/sales](http://www.onsemi.com/support/sales)

## Looking for pricing, stock, or lifecycle information?

Click below to explore more details on WIN SOURCE:

 [View FPF2260ATMX](#) on WIN SOURCE

 [ON Semiconductor](#) Information

## Optimize Your Supply Chain with WIN SOURCE Solutions

-  Global Sourcing Solution
-  Obsolete Management
-  Cost Control Management
-  Shortage Management
-  Alternative Solution
-  Excess Inventory Management