



**THE DATASHEET OF  
BU2630F-E2**



# Dual PLL frequency synthesizer

## BU2630F / BU2630FV

The BU2630F/BU2630FV are a CMOS LSI with an internal dual PLL synthesizer.

VCOs for transmission and reception can be controlled independently, and the reference frequency and main counter settings can also be programmed separately. This product is designed for applications involving cordless telephones and communications equipment worldwide.

### ●Applications

Cordless telephones, amateur short wave radios, industrial transceivers, VHF/UHF frequency generators, and others

### ●Features

- |  |   |
|--|---|
| 1) Operation possible at up to 80MHz ( $V_{DD} = 2.5$ ). | 3) 16-bit main counter.                         |
| 2) Low current dissipation                               | 4) Internal 14-bit reference frequency counter. |
| Dual-system operation : 2.2mA (typ), $V_{DD} = 3V$       | 5) Unlock detection possible.                   |
| Single-system operation : 1.2mA (typ), $V_{DD} = 3V$     | 6) Four output ports. (open drain)              |
| Non-operating state : 0.2mA (typ), $V_{DD} = 3V$         | 7) Control possible using 3-wire serial input.  |

### ●Block diagram

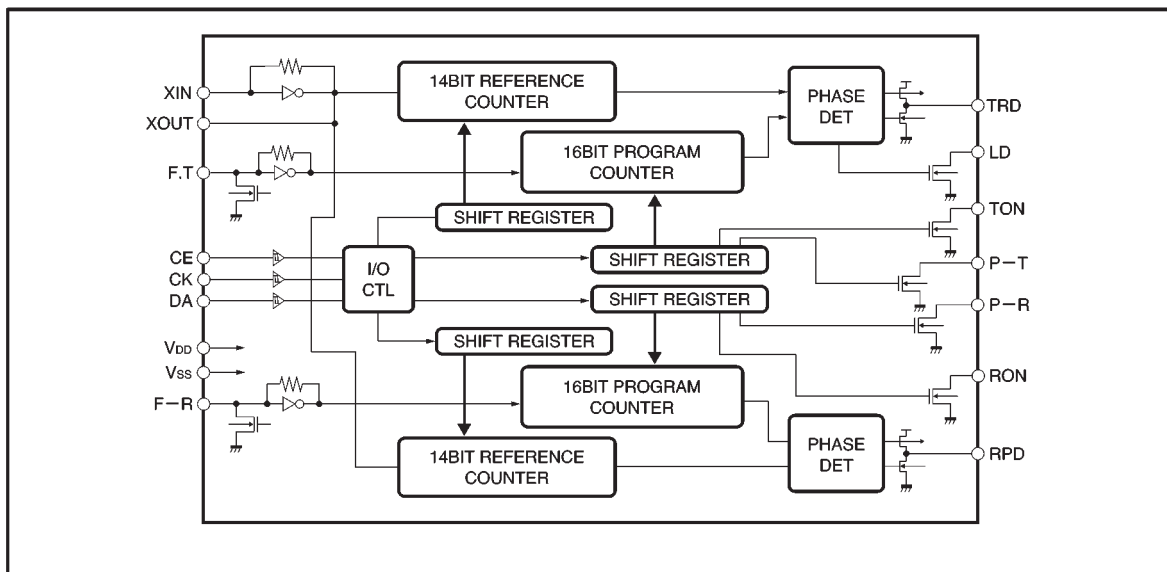

## ● Absolute maximum ratings (Ta = 25°C)

Parameter	Symbol	Limits	Unit
Power supply voltage	V <sub>DD</sub>	-0.3~+7.0	V
Power dissipation	BU2630F	Pd	mW
	BU2630FV		
			350*2
Operating temperature	T <sub>opr</sub>	-40~+85	°C
Storage temperature	T <sub>stg</sub>	-55~+125	°C

\*1 Reduced by 5.0mW for each increase in Ta of 1°C over 25°C.

\*2 Reduced by 3.5mW for each increase in Ta of 1°C over 25°C.

## ● Recommended operating conditions (Ta = 25°C)

Parameter	Symbol	Min.	Typ.	Max.	Unit
Power supply voltage	V <sub>DD</sub>	2.5	3.0	5.5	V

## ● Pin descriptions

Pin No.	Pin name	Name	Function	I/O circuit
16	XOUT	Crystal resonator	For reference frequency	TYPE A
1	XIN			
2	V <sub>SS</sub>			
3	RPD	Phase comparator output	This is LO if the locally divided value is higher than the reference frequency, HI if it is lower, and Z if it matches.	TYPE E
4	P-R	Output port	This is controlled by the input data.	TYPE D
5	RON			
6	F-R	VCO input	Local input for reception	TYPE F
7	CE	Chip enable clock signal serial data	When CE is HIGH, the DA synchronized to the rise of CK is read into the internal shift register, and is latched at the timing of the CE fall.	TYPE B
8	CK			
9	DA			
10	LD	Unlock output	This goes ON when the PLL is unlocked on the transmission side	TYPE D
11	F-T	VCO input	Local input for transmission	TYPE F
12	TON	Output port	This is controlled by the input data	TYPE D
13	P-T			
14	TPD	Phase comparator output	This is LO if the locally divided value is higher than the reference frequency, HI if it is lower, and Z if it matches.	TYPE E
15	V <sub>DD</sub>	Power supply	2.5~5.5V	

● Input/output circuits

TYPE A

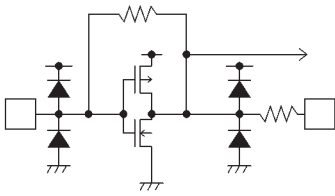

TYPE B

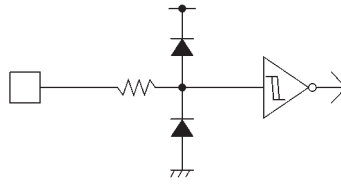

TYPE C

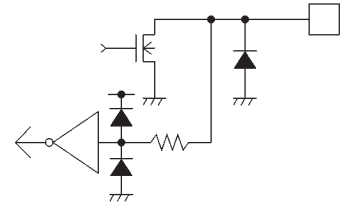

TYPE D

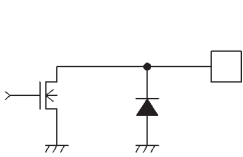

TYPE E

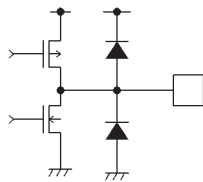

TYPE F

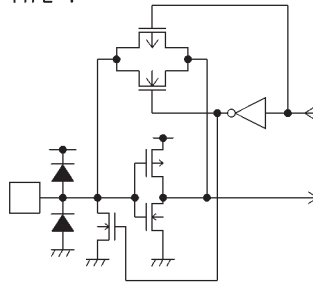

TYPE I

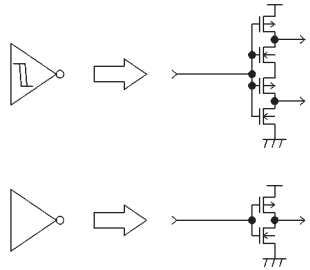

● Electrical characteristics (unless otherwise noted, Ta = 25°C, V<sub>DD</sub> = 3.0V, V<sub>SS</sub> = 0V)

Parameter	Symbol	Min.	Typ.	Max.	Unit	Conditions
Power supply current 1	I <sub>DD1</sub>	—	2.2	3.0	mA	Dual-system operation
Power supply current 2	I <sub>DD2</sub>	—	1.2	2.0	mA	Single-system operation
Power supply current 3	I <sub>DD3</sub>	—	0.2	0.3	mA	With operation stopped: XTAL = 10.24 MHz
Input high level voltage 1	V <sub>IH1</sub>	0.8V <sub>DD</sub>	—	—	V	CE CK DA
Input low level voltage 1	V <sub>IL1</sub>	—	—	0.2V <sub>DD</sub>	V	CE CK DA
Input high level current 1	I <sub>IH1</sub>	—	—	1.0	μA	CE CK DA V <sub>IN</sub> =V <sub>DD</sub>
Input high level current 2	I <sub>IH2</sub>	—	0.3	—	μA	XIN V <sub>IN</sub> =V <sub>DD</sub>
Input high level current 3	I <sub>IH3</sub>	—	5.0	—	μA	F-T F-R V <sub>IN</sub> =V <sub>DD</sub>
Input low level current 1	I <sub>IL1</sub>	-1.0	—	—	μA	CE CK DA V <sub>IN</sub> =V <sub>SS</sub>
Input low level current 2	I <sub>IL2</sub>	—	-0.3	—	μA	XIN V <sub>IN</sub> =V <sub>SS</sub>
Input low level current 3	I <sub>IL3</sub>	—	-5.0	—	μA	F-T F-R V <sub>IN</sub> =V <sub>SS</sub>
Output low level voltage 1	V <sub>OL1</sub>	—	0.3	0.5	V	LD TON P-T RON P-R I <sub>O</sub> =1.0mA
Off level leakage current 1	I <sub>OFF1</sub>	—	—	1.0	μA	LD TON P-T RON P-R V <sub>O</sub> =10V
Output low level voltage 2	V <sub>OL2</sub>	—	—	0.3	V	F-T F-R I <sub>OUT</sub> =0.1mA
Output high level voltage	V <sub>OH3</sub>	V <sub>DD</sub> -50	V <sub>DD</sub> -1.0	—	mV	TPD RPD I <sub>OUT</sub> =-0 μA
Output low level voltage	V <sub>OL3</sub>	—	1.3	50	mV	TPD RPD I <sub>OUT</sub> =0 μA
Output high level voltage	V <sub>OH4</sub>	V <sub>DD</sub> -100	V <sub>DD</sub> -40	—	mV	TPD RPD I <sub>OUT</sub> =-100 μA
Output low level voltage	V <sub>OL4</sub>	—	30	100	mV	TPD RPD I <sub>OUT</sub> =100 μA
Off level leakage current 2	I <sub>OFF2</sub>	—	—	100	nA	TPD RPD V <sub>OUT</sub> =V <sub>DD</sub>
Off level leakage current 3	I <sub>OFF3</sub>	-100	—	—	nA	TPD RPD V <sub>OUT</sub> =V <sub>SS</sub>
Internal feedback resistance 1	R <sub>F1</sub>	—	10	—	MΩ	XIN
Internal feedback resistance 2	R <sub>F2</sub>	—	500	—	kΩ	F-T F-R
Input frequency 1	F <sub>IN1</sub>	1.0	10.24	16.0	MHz	XIN, sine wave, C coupling
Input frequency 2	F <sub>IN2</sub>	1.0	—	20	MHz	F-T F-R, sine wave, C coupling*2, V <sub>IN</sub> = 100 mVrms
Input frequency 3	F <sub>IN3</sub>	50	—	80	MHz	F-T F-R, sine wave, C coupling*2, V <sub>IN</sub> = 100 mVrms
Input frequency 4	F <sub>IN4</sub>	20	—	50	MHz	F-T F-R, sine wave, C coupling*2, V <sub>IN</sub> = 50 mVrms
Input frequency 5*1	F <sub>IN5</sub>	0.4	—	20	MHz	F-T F-R, sine wave, C coupling*2, V <sub>IN</sub> = 100mVrms
Maximum input amplitude	F <sub>INMax.</sub>	—	—	V <sub>DD</sub> +0.3	V <sub>P-P</sub>	XIN, F-T F-R
Input capacitance	C <sub>IN</sub>	—	4	7	PF	F-T F-R
Minimum pulse width	TW	1.0	—	—	μs	CK, DA
Input data rise time	TR	—	—	300	ns	CK, DA
Input data fall time	TF	—	—	300	ns	CE, CK, DA

© Not designed for radiation resistance.

\*1 PS = 1

\*2 Minimum input level at which operation is possible

Divider values which can be set

Program divider: PS = 0: 256 to 65535, PS = 1: 3 to 4095

Reference frequency divider: 3 to 16383

●Circuit operation

Input data switching characteristics

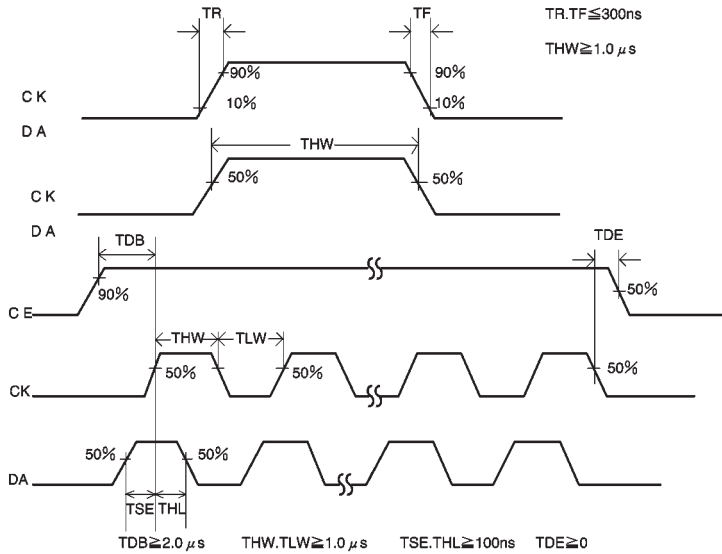

Input data format

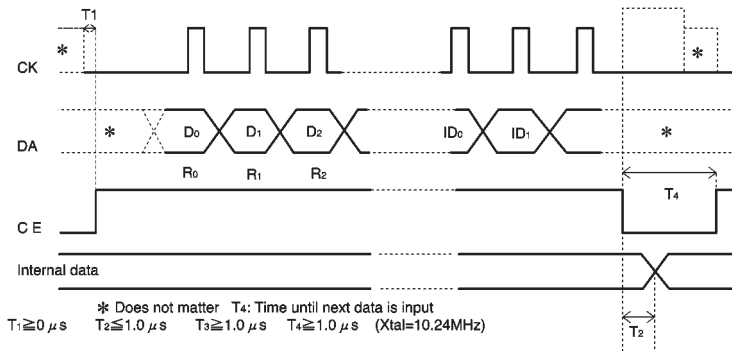

Programmable divider and control data input: TX side (ID<sub>0</sub> = 0, ID<sub>1</sub> = 0), RX side (ID<sub>0</sub> = 1, ID<sub>1</sub> = 0)

LSB ← Input from D<sub>0</sub>

D <sub>0</sub>	D <sub>1</sub>	D <sub>2</sub>	D <sub>3</sub>	D <sub>4</sub>	D <sub>5</sub>	D <sub>6</sub>	D <sub>7</sub>	D <sub>8</sub>	D <sub>9</sub>	D <sub>10</sub>	D <sub>11</sub>	D <sub>12</sub>	D <sub>13</sub>	D <sub>14</sub>	D <sub>15</sub>
				P-T	TON	OFF	PS	T <sub>0</sub>	T <sub>1</sub>	ID <sub>0</sub>	ID <sub>1</sub>				
				(P-R	TON	OFF	PS	T <sub>0</sub>	T <sub>1</sub> )						

MSB

Reference frequency divider data input: TX side (ID<sub>0</sub> = 0, ID<sub>1</sub> = 1), RX side (ID<sub>0</sub> = 1, ID<sub>1</sub> = 1)

R <sub>0</sub>	R <sub>1</sub>	R <sub>2</sub>	R <sub>3</sub>	R <sub>4</sub>	R <sub>5</sub>	R <sub>6</sub>	R <sub>7</sub>	R <sub>8</sub>	R <sub>9</sub>	R <sub>10</sub>	R <sub>11</sub>	R <sub>12</sub>	R <sub>13</sub>	PL	PH
				*	*	LD <sub>0</sub>	LD <sub>1</sub>	*	*	ID <sub>0</sub>	ID <sub>1</sub>				

MSB

\* Does not matter (LD<sub>0</sub> and LD<sub>10</sub> are valid on TX side only)

Description of data

(1) Programmable divider data: D<sub>0</sub> ~ D<sub>15</sub>

D <sub>0</sub>	D <sub>1</sub>	D <sub>2</sub>	D <sub>3</sub>	D <sub>4</sub>	D <sub>5</sub>	D <sub>6</sub>	D <sub>7</sub>	D <sub>8</sub>	D <sub>9</sub>	D <sub>10</sub>	D <sub>11</sub>	D <sub>12</sub>	D <sub>13</sub>	D <sub>14</sub>	D <sub>15</sub>
Example: For a transmission frequency of 46.610MHz and a reference frequency of 5.00 kHz															
No. of divisions: 46.610 ÷ 5.00 kHz = 9322 (D) = 246A (H)															
0	1	0	1	0	1	1	0	0	0	1	0	0	1	0	0
A				6				4				2			

(2) Reference frequency data: R<sub>0</sub> ~ R<sub>13</sub>

R <sub>0</sub>	R <sub>1</sub>	R <sub>2</sub>	R <sub>3</sub>	R <sub>4</sub>	R <sub>5</sub>	R <sub>6</sub>	R <sub>7</sub>	R <sub>8</sub>	R <sub>9</sub>	R <sub>10</sub>	R <sub>11</sub>	R <sub>12</sub>	R <sub>13</sub>
Example: When XTAL = 10.24 MHz and reference frequency is 5.00 kHz													
No. of divisions: 10.24 MHz ÷ 5.00 kHz = 2048 (D) = 800 (H)													
0	0	0	0	0	0	0	0	0	0	0	1	0	0
0				0				8				0	

(3) Output port control data : P-T (P-R) TON (RON)

1 : Open drain output ON (LO)

0 : Open drain output OFF (HI)

(4) OFF transmission side (reception side) : Operation stopped

F - T (F - R) pull-down : TPD (RPD) high-impedance, LD = OFF

(5) PS

Programmable device change : No. of divisions = 3 ~ 4095

D <sub>0</sub>	D <sub>1</sub>	D <sub>2</sub>	D <sub>3</sub>	D <sub>4</sub>	D <sub>5</sub>	D <sub>6</sub>	D <sub>7</sub>	D <sub>8</sub>	D <sub>9</sub>	D <sub>10</sub>	D <sub>11</sub>	D <sub>12</sub>	D <sub>13</sub>	D <sub>14</sub>	D <sub>15</sub>
*	*	*	*	LSB											MSB
DONT CARE															

- (6) PL, PH, and PD pin control
  - 0 0 : PLL operation
  - 1 0 : Forced LO state
  - 0 1 : Forced HI state
  - 1 1 : Forced LO state
- (7) LD<sub>0</sub>, LD<sub>1</sub>, LD pin control (valid only on TX side)
  - 0 0 : ON when unlocked (LO)
  - 0 1 : Air pulse output
  - 1 0 : Forced ON state (LO)
  - 1 1 : Forced OFF state (HI)
- (8) Input (00) to test T0 and T1.

●Application example

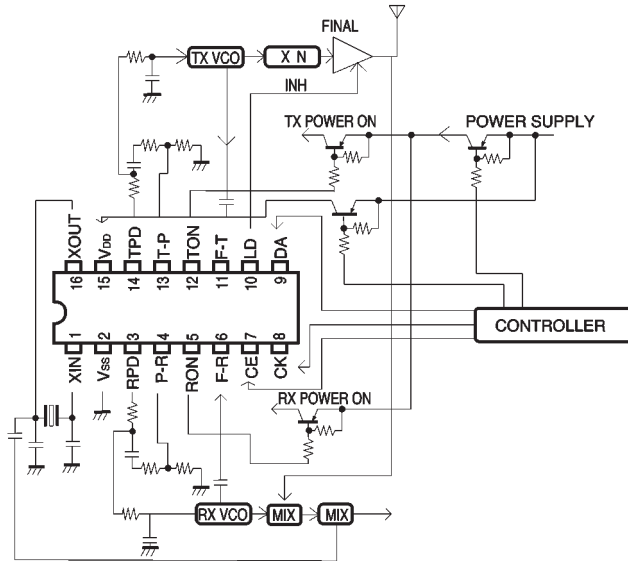

※: Immediately after the power supply is turned on, the various pins remain unstable until data is input.

Fig. 1

●Electrical characteristic curves

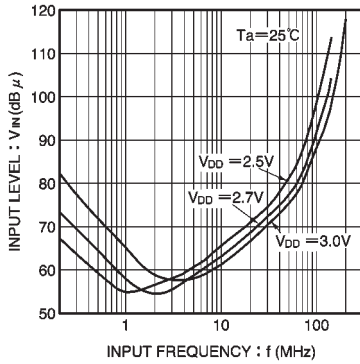

Fig. 2 Input frequency vs. input level

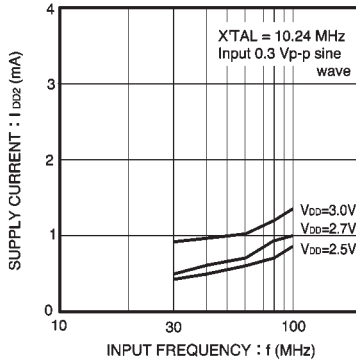

Fig. 3 Input frequency vs. supply current (for single operation)

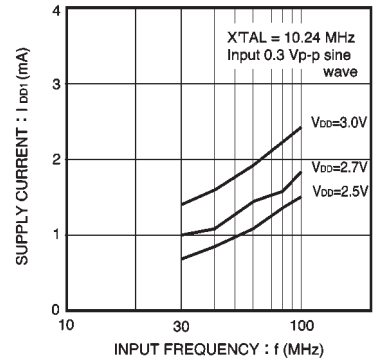
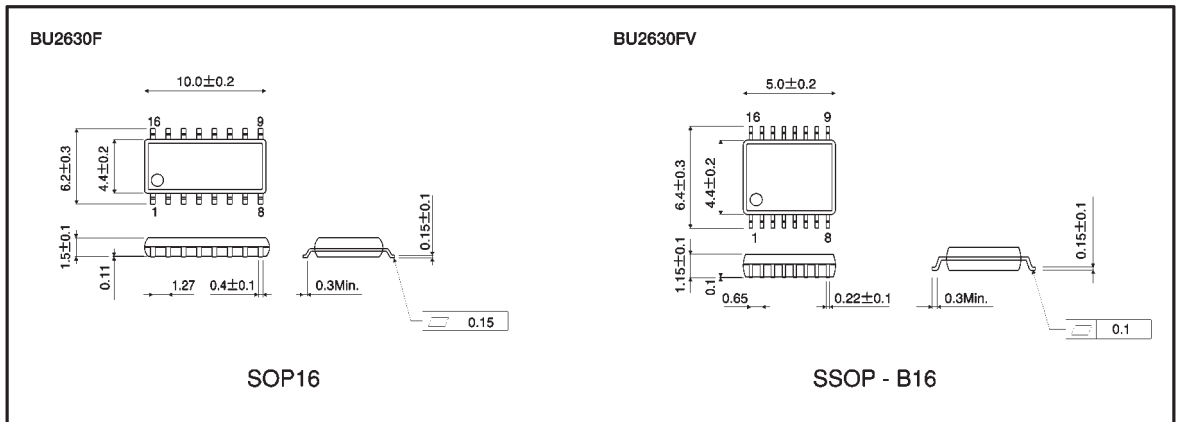

Fig. 4 Input frequency vs. supply current (for dual operation)

●External dimensions (Units: mm)



### Notes

- No technical content pages of this document may be reproduced in any form or transmitted by any means without prior permission of ROHM CO.,LTD.
- The contents described herein are subject to change without notice. The specifications for the product described in this document are for reference only. Upon actual use, therefore, please request that specifications to be separately delivered.
- Application circuit diagrams and circuit constants contained herein are shown as examples of standard use and operation. Please pay careful attention to the peripheral conditions when designing circuits and deciding upon circuit constants in the set.
- Any data, including, but not limited to application circuit diagrams information, described herein are intended only as illustrations of such devices and not as the specifications for such devices. ROHM CO.,LTD. disclaims any warranty that any use of such devices shall be free from infringement of any third party's intellectual property rights or other proprietary rights, and further, assumes no liability of whatsoever nature in the event of any such infringement, or arising from or connected with or related to the use of such devices.
- Upon the sale of any such devices, other than for buyer's right to use such devices itself, resell or otherwise dispose of the same, no express or implied right or license to practice or commercially exploit any intellectual property rights or other proprietary rights owned or controlled by
- ROHM CO., LTD. is granted to any such buyer.
- Products listed in this document use silicon as a basic material.  
Products listed in this document are no antiradiation design.

The products listed in this document are designed to be used with ordinary electronic equipment or devices (such as audio visual equipment, office-automation equipment, communications devices, electrical appliances and electronic toys).

Should you intend to use these products with equipment or devices which require an extremely high level of reliability and the malfunction of which would directly endanger human life (such as medical instruments, transportation equipment, aerospace machinery, nuclear-reactor controllers, fuel controllers and other safety devices), please be sure to consult with our sales representative in advance.



#### About Export Control Order in Japan

Products described herein are the objects of controlled goods in Annex 1 (Item 16) of Export Trade Control Order in Japan.

In case of export from Japan, please confirm if it applies to "objective" criteria or an "informed" (by MITI clause) on the basis of "catch all controls for Non-Proliferation of Weapons of Mass Destruction.

## Looking for pricing, stock, or lifecycle information?

Click below to explore more details on WIN SOURCE:

-  [View BU2630F-E2 on WIN SOURCE](#)
-  [Rohm Semiconductor Information](#)

## Optimize Your Supply Chain with WIN SOURCE Solutions

-  Global Sourcing Solution
-  Obsolete Management
-  Cost Control Management
-  Shortage Management
-  Alternative Solution
-  Excess Inventory Management