



**THE DATASHEET OF
PC123Y23FP9F**



TO ; _____

S P E C I F I C A T I O N S

Product Name PHOTOCOUPLER

Model No. PC123

【Business dealing name : PC123Y83FP9F】

These specifications contain 16 pages including the cover and appendix.
This specification sheets and attached sheets shall be both side copy.
After confirmation of the contents, please be sure to send back copy of the
Specifications with approving signature on each.
If you have any objections, please contact us before issuing purchasing order.

Accepted by:

By : _____
Name : _____
Title : _____
Date : _____

By : _____
Name : _____
Title : _____
Date : _____

Sharp Corporation
By : G.O
Name : T. Ichinose,
Title : General Manager, Head of
Development Dept. II
System Device Business Unit
Electronic Components and Devices Company
Date : Mar. 2, 2016

Reviewed by : _____ Prepared by : _____
By : N.Y. By : H.S
Name : N.Yokogawa Name : H.Shoji
Title : Senior Manager Title : Supervisor
Date : Mar. 2, 2016 Date : Mar 2, 2016

1. These specification sheets include materials protected under copyright of Sharp Corporation ("Sharp").
Please handle with great cares and do not reproduce or cause anyone to reproduce them without Sharp's consent.
2. When using this Sharp product, please observe the absolute maximum ratings, other conditions and instructions for use described in the specification sheets, as well as the precautions mentioned below.
Sharp assumes no responsibility for any damages resulting from use of the product which does not comply with absolute maximum ratings, other conditions and instructions for use included in the specification sheets, and the precautions mentioned below.

(Precautions)

- (1) In making catalogue or instruction manual based on the specification sheets, please verify the validity of the catalogue or instruction manuals after assembling Sharp products in customer's products at the responsibility of customer.
- (2) This Sharp product is designed for use in the following application areas ;
 - Computers • OA equipment • Telecommunication equipment (Terminal) • Measuring equipment
 - Tooling machines • Audio visual equipment • Home appliancesIf the use of the Sharp product in the above application areas is for equipment listed in paragraphs (3) or (4), please be sure to observe the precautions given in those respective paragraphs.
- (3) Appropriate measures, such as fail-safe design and redundant design considering the safety design of the overall system and equipment, should be taken to ensure reliability and safety when Sharp product is used for equipment in responsibility of customer which demands high reliability and safety in function and precision, such as ;
 - Transportation control and safety equipment (aircraft, train, automobile etc.)
 - Traffic signals • Gas leakage sensor breakers • Rescue and security equipment • Other safety equipment
- (4) Sharp product is designed for consumer goods and controlled as consumer goods in production and quality.
Please do not use this product for equipment which require extremely high reliability and safety in function and precision, such as ;
 - Space equipment • Telecommunication equipment (for trunk lines)
 - Nuclear power control equipment • Medical equipment
- (5) Please contact and consult with a Sharp sales representative if there are any question regarding interpretation of the above four paragraphs.

3. Disclaimer

The warranty period for Sharp product is one (1) year after shipment.

During the period, if there are any products problem, Sharp will repair (if applicable), replace or refund.

Except the above, both parties will discuss to cope with the problems.

The failed Sharp product after the above one (1) year period will be coped with by Sharp, provided that both parties shall discuss and determine on sharing responsibility based on the analysis results thereof subject to the above scope of warranty.

The warranty described herein is only for Sharp product itself which are purchased by or delivered to customer.

Damages arising from Sharp product malfunction or failure shall be excepted.

Sharp will not be responsible for the Sharp product due to the malfunction or failures thereof which are caused by:

- (1) storage keep trouble during the inventory in the marketing channel.
- (2) intentional act, negligence or wrong/poor handling.
- (3) equipment which Sharp products are connected to or mounted in.
- (4) disassembling, reforming or changing Sharp products.
- (5) installation problem.
- (6) act of God or other disaster (natural disaster, fire, flood, etc.)
- (7) external factors (abnormal voltage, abnormal electromagnetic wave, fire, etc.)
- (8) special environment (factory, coastal areas, hot spring area, etc.)
- (9) phenomenon which cannot be foreseen based on the practical technologies at the time of shipment.
- (10) the factors not included in the product specification sheet.

4. Please contact and consult with a Sharp sales representative for any questions about Sharp product.

5. Warranty term and warranty limits

【Warranty term】

The warranty term for the shipped product shall be for 1 year after shipping to the designated place by the ordered customer.

【Warranty limits】

SHARP supplies the replacement when this SHARP product shall be failed by SHARP's responsibility during above warranty term. However, this warranty is excluded in case of the following.

- (1) In case of improper handling and using by the customer.
- (2) In case of that the cause of the failure is caused by the reason other than this SHARP product.
- (3) In case of modification and repairing by person other than SHARP responsibility is not for SHARP.
- (4) In case of a calamity, a disaster and such as the case when that responsibility is not for SHARP.

This warranty herein means the warranty for this SHARP product itself, SHARP takes no responsibility for any damage caused by the failure of this SHARP product.

1. Application

This specification applies to the outline and characteristics of photocoupler Model No. PC123.(Lead-Free and Halogen free Type).

2. Outline Refer to the attached sheet, page 6.
3. Ratings and characteristics Refer to the attached sheet, page 7, 8.
4. Reliability Refer to the attached sheet, page 9.
5. Outgoing inspection Refer to the attached sheet, page 10.

6. Supplement

6.1 Isolation voltage shall be measured in the following method.

- (1) Short between anode and cathode on the primary side and between collector and emitter on the secondary side.
 - (2) The dielectric withstanding tester with zero-cross circuit shall be used.
 - (3) The wave form of applied voltage shall be a sine wave.
- (It is recommended that the isolation voltage be measured in insulation oil.)

6.2 Packing specifications Refer to the attached sheet, page 11, 12, 13.

6.3 Collector current (Ic) Delivery rank table ("O" mark indicates business dealing name of ordered product)

Rank at delivery	* Business dealing name	Rank mark	Ic (mA)	Test condition
	PC123Y13FP9F	L	2.5 to 7.5	$I_F=5\text{mA}$ $V_{CE}=5\text{V}$ $T_a=25^\circ\text{C}$
	PC123Y23FP9F	M	5.0 to 12.5	
○	PC123Y83FP9F	E	5.0 to 10.0	
	PC123Y93FP9F	C	8.0 to 15.0	

6.4 The relevant models are the models Approved by VDE according to DIN EN60747-5-5.

Approved Model No. : PC123

VDE approved No. : 40015248 (According to the specification DIN EN60747-5-5)

- Operating isolation voltage V_{IORM} : 1140V (Peak)
- Transient voltage : 8000V (Peak)
- Pollution : 2
- Clearances distance (Between input and output) : 8.0mm (MIN.)
- Creep age distance (Between input and output) : 8.0mm (MIN.)
- Isolation thickness between input and output : 0.4mm (MIN.)
- Safety limit values
 - Current (I_{si}) : 400mA (Diode side)
 - Power (P_{si}) : 700mW (Phototransistor side)
 - Temperature (T_{si}) : 175°C

In order to keep safety electric isolation of photocoupler, please set the protective circuit to keep within safety limit values when the actual application equipment troubled.

- Indication of VDE approval "  " is printed on minimum unit package.

Isolation specification according to EN 60747-5-5

Parameter	Symbol	Condition	Rating	Unit	Remark
Class of environmental test	-	-	55/110/21	-	-
Pollution	-	-	2	-	-
Maximum operating isolation voltage	$V_{IORM(PEAK)}$	-	1140	V	Refer to the Diagram 1,2 (Page 5/13)
Partial discharge test voltage (Between input and output)					
Diagram 1	$V_{m(PEAK)}$	$t_m=60s, q_c < 5pC$	1275	V	
Diagram 2		$t_{st1}=1s, q_c < 5pC$	1594	V	
Maximum over-voltage	$V_{in(a)(PEAK)}$	$t_{in}=10s$	8000	V	
Safety maximum ratings					-
1) Case temperature	T_{si}	$I_f=0, P_c=0,$	175	°C	
2) Input current	I_{si}	$P_c=0$	400	mA	
3) Electric power (Output or Total power dissipation)	P_{si}	-	700	mW	

Precautions in performing isolation test

- (1) Partial discharge test methods shall be the ones according to the specifications of EN 60747-5-5.
- (2) Please don't carry out isolation test (V_{iso}) over $V_{in(a)}$.
This product deteriorates isolation characteristics by partial discharge due to applying high voltage (ex. $V_{in(a)}$).
And there is possibility that partial discharge occurs in operating isolation voltage. (V_{IORM}).

6.5 This product is applying for the following safety standards.

UL, CSA, BSI, SEMKO, DEMKO, NEMKO, FIMKO, VDE, and CQC.

6.6 This product is not designed against irradiation.

This product is assembled with electrical input and output.

This product incorporates non-coherent light emitting diode.

6.7 ODS materials

This product shall not contain the following materials.

Also, the following materials shall not be used in the production process for this product.

Materials for ODS : CFCs, Halon, Carbon tetrachloride, 1.1.1-Trichloroethane (Methyl chloroform)

6.8 Specified brominated flame retardants

Specified brominated flame retardants (PBB and PBDE) are not used in this device at all.

6.9 Compliance with each regulation

(1) The RoHS directive(2011/65/EU)

This product complies with the RoHS directive(2011/65/EU).

Object substances: mercury, lead, cadmium, hexavalent chromium, polybrominated biphenyls (PBB) and polybrominated diphenyl ethers (PBDE)

(2) Content of six substances specified in Management Methods for Control of Pollution Caused by Electronic

Information Products Regulation (Chinese: 电子信息产品污染控制管理办法).

Marking Styles for the Names and Contents of the Hazardous Substances

Category	Hazardous Substances					
	Lead (Pb)	Mercury (Hg)	Cadmium (Cd)	Hexavalent chromium (Cr ⁶⁺)	Polybrominated biphenyls (PBB)	Polybrominated diphenyl ethers (PBDE)
Photocoupler	○	○	○	○	○	○

This table is prepared in accordance with the provisions of SJ/T 11364.

○ : Indicates that said hazardous substance contained in all of the homogeneous materials for this part is below the limit requirement of GB/T 26572.

(3) This product complies with "Halogen free".

"Halogen free" about this product is defined as follows.

The concentration ratio of Chlorinate and Bromine in raw material and indirect material , finished product can not exceed 900 ppm, the total concentration of the 2 substance should not exceed 1500 ppm.

7. Notes

Precautions for photocouplers : Attachment-1

Method of Diagram 1: Breakdown test (Apply to type test and sampling test)

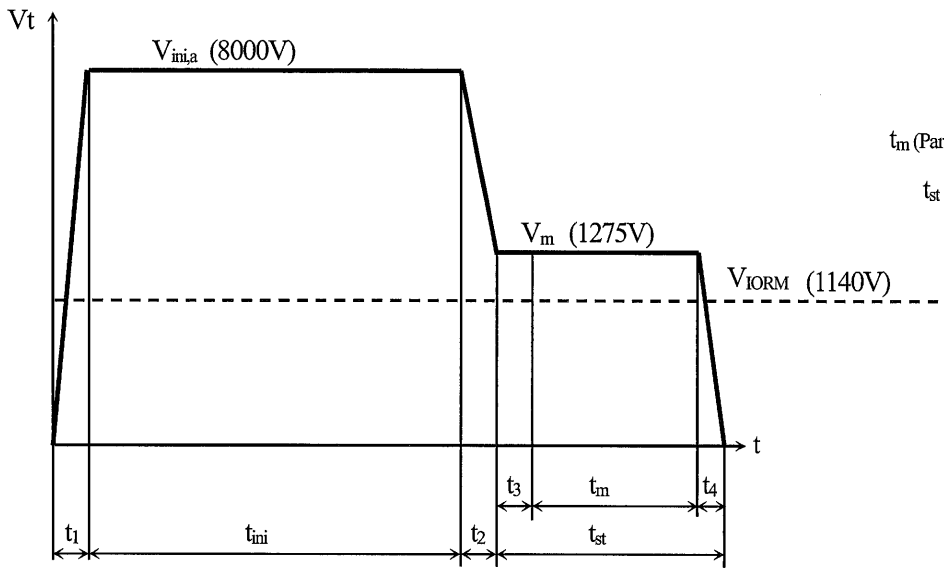

- $t_1, t_2 = 1 \text{ to } 10 \text{ s}$
- $t_3, t_4 = 1 \text{ s}$
- $t_m \text{ (Partial-discharge measuring time)} = 60 \text{ s}$
- $t_{st} \text{ (Partial-discharge stress time)} = 62 \text{ s}$
- $t_{ini} = 10 \text{ s}$

Method of Diagram 2: Non breakdown test (Apply to all device test)

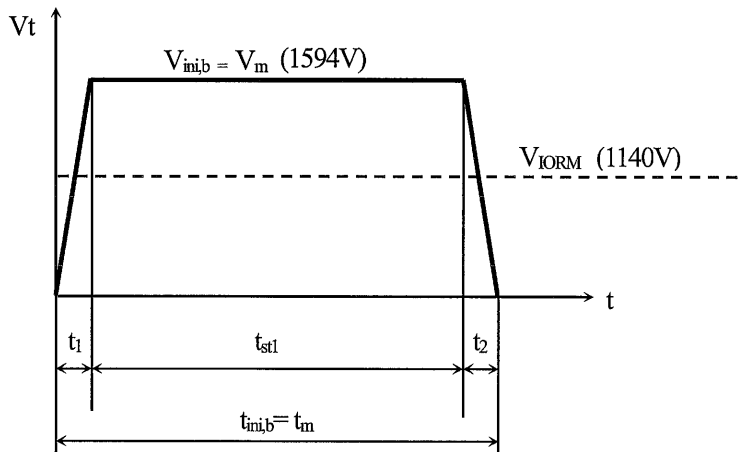

- $t_1, t_2 = 0.1 \text{ s}$
- $t_{st1} \text{ (Isolation test stress time)} = 1 \text{ s}$
- $t_{inib-t_m} \text{ (Partial-discharge measuring time)} = 1.2 \text{ s}$

2. Outline

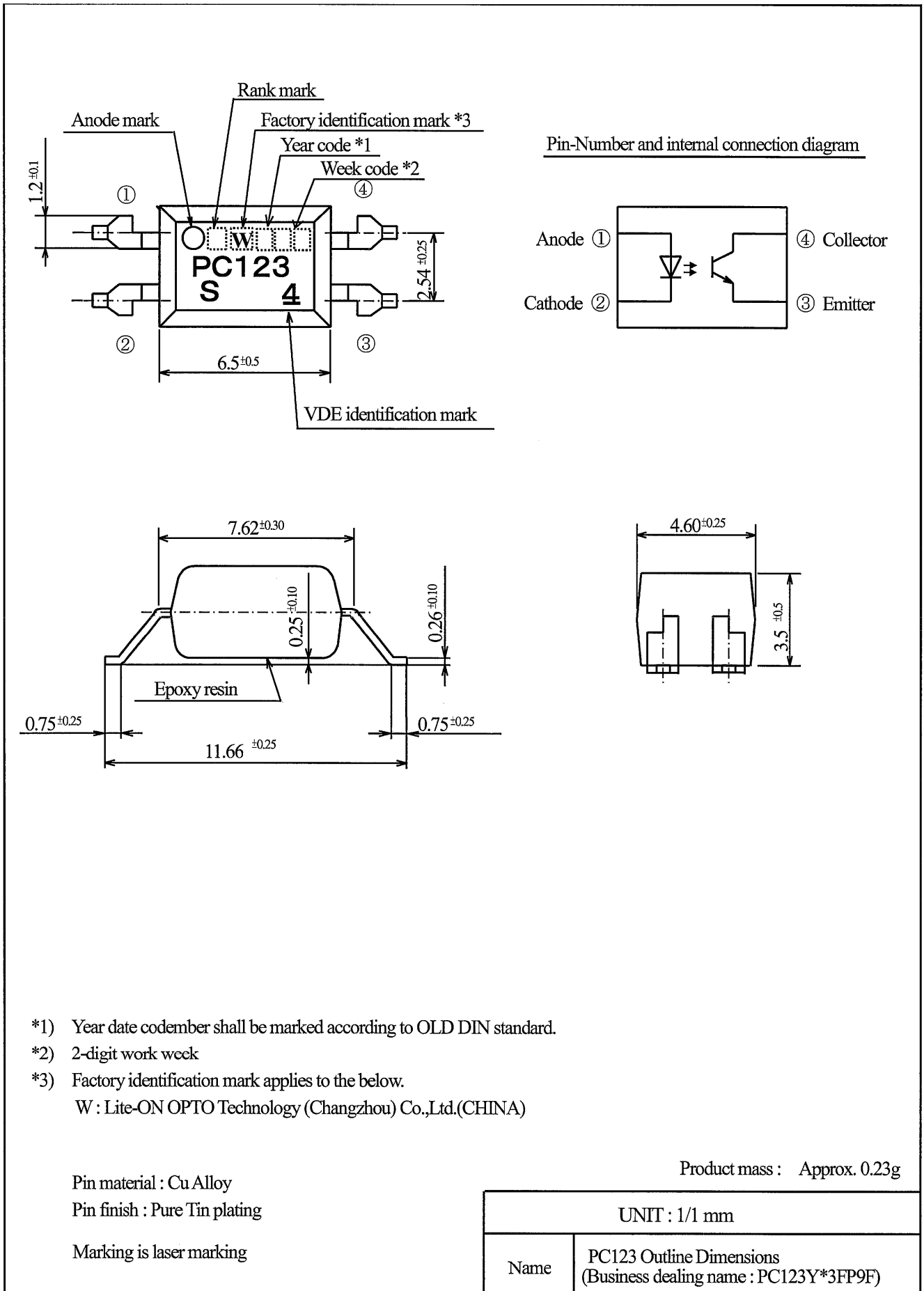

*1) Year date codemember shall be marked according to OLD DIN standard.
 *2) 2-digit work week
 *3) Factory identification mark applies to the below.
 W : Lite-ON OPTO Technology (Changzhou) Co.,Ltd.(CHINA)

Pin material : Cu Alloy
 Pin finish : Pure Tin plating
 Marking is laser marking

Product mass : Approx. 0.23g

UNIT : 1/1 mm	
Name	PC123 Outline Dimensions (Business dealing name : PC123Y*3FP9F)

3. Ratings and characteristics

3.1 Absolute maximum ratings

Ta=25°C

Parameter		Symbol	Rating	Unit
Input	Forward current *1	I _F	50	mA
	Peak forward current	I _{FM}	1	A
	Reverse voltage	V _R	6	V
	Power dissipation	P	70	mW
Output	Collector-emitter voltage	V _{CEO}	70	V
	Emitter-collector voltage	V _{ECO}	6	V
	Collector current	I _c	50	mA
	Collector power dissipation *1	P _c	150	mW
Total power dissipation		P _{tot}	200	mW
Operating temperature		T _{opr}	-30 to +100	°C
Storage temperature		T _{stg}	-55 to +125	°C
Isolation voltage *2		V _{iso (rms)}	5	kV
Soldering temperature *3		T _{sol}	270	°C

*1 The derating factors of absolute maximum ratings due to ambient temperature are shown in Fig. 1 to 2.

*2 AC For 1 min, 40 to 60%RH

Isolation voltage shall be measured using the following method.

(1) Short between anode and cathode on the primary side and between collector and emitter on the secondary side.

(2) The isolation voltage tester with zero-cross circuit shall be used.

(3) The waveform of applied voltage shall be a sine wave.

*3 For 10s

3.2 Electro-optical characteristics

Ta=25°C

Parameter		Symbol	Condition	MIN.	TYP.	MAX.	Unit
Input	Forward voltage	V _F	I _F =20mA	-	1.2	1.4	V
	Reverse current	I _R	V _R =4V	-	-	10	μA
	Terminal capacitance	C _t	V=0, f=1kHz	-	30	250	pF
Output	Dark current	I _{CEO}	V _{CE} =50V, I _F =0	-	-	100	nA
	Collector-emitter breakdown voltage	BV _{CEO}	I _c =0.1mA, I _F =0	70	-	-	V
	Emitter-collector breakdown voltage	BV _{ECO}	I _E =10 μA, I _F =0	6	-	-	V
Transfer characteristics	Collector current	I _c	I _F =5mA, V _{CE} =5V	2.5	-	20	mA
	*5 Current Transfer Ratio	CTR		50	-	400	%
	Collector-emitter saturation voltage	V _{CE(sat)}	I _F =20mA, I _c =1mA	-	0.1	0.2	V
	Isolation resistance	R _{ISO}	DC500V 40 to 60%RH	10 ¹²	-	-	Ω
	Floating capacitance	C _f	V=0, f=1MHz	-	0.6	1.0	pF
	Cut-off frequency	f _c	V _{CE} =5V, I _c =2mA R _L =100Ω, -3dB	-	80	-	kHz
	Response time (Rise)	t _r	V _{CE} =2V, I _c =2mA R _L =100Ω	-	4	18	μs
Response time (Fall)	t _f	-		3	18	μs	

*4 CTR (%) = (I_c / I_F) × 100

(Fig. 1) Forward current vs. ambient temperature

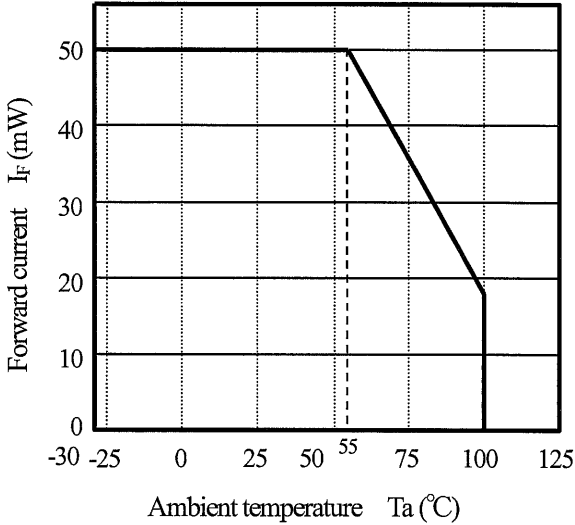

(Fig. 2) Collector power dissipation vs. ambient temperature

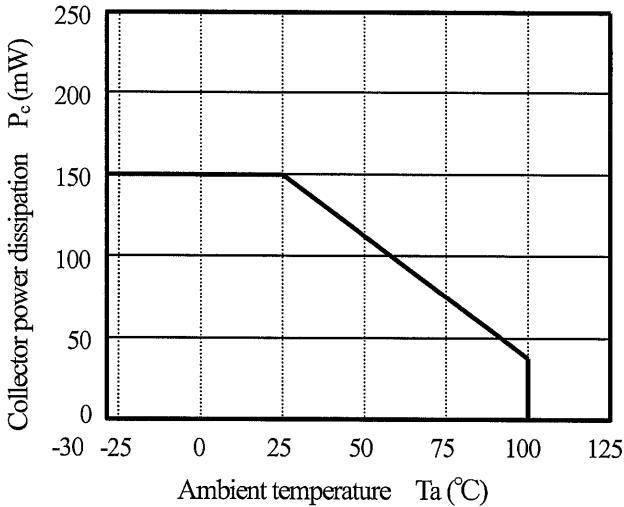

4. Reliability

The reliability of products shall satisfy items listed below.

Test item as require

Test title	Test condition
Pre-condition test	125°C=24h, 85°C 85%RH=168h, and IR reflow 260°C peak=3Cycles
Temperature cycling test	Ta=-55~125°C, Dwell time=15min per zone, 1000 cycles
Room temperature operation life test	Ta=25°C, If=50mA, 1000h
High temperature & high humidity bias test	Ta=85°C, 85%RH, V _{CE} =64V, 1000h
High temperature bias test	Ta=110°C, V _{CE} =80V, 1000h
High temperature storage test	Ta=150°C, 1000h
Low temperature storage test	Ta=-55°C, 1000h
Autoclave	Temperature=121°C, 100%RH and 15Psi, 168h

Spec limit of product

Parameter	Symbol	Mesurement condition	Ta=25°C		
			MIN.	MAX.	Unit
Forward voltage	V _F	I _F =20mA	-	1.4	V
Reverse current	I _R	V _R =4V	-	10	μA
Dark current	I _{CEO}	V _{CE} =50V	-	100	nA
Collector-emitter breakdown voltage	BV _{CEO}	I _C =0.1mA	70	-	V
Emitter-collector breakdown voltage	BV _{ECO}	I _E =10 μA	6	-	V
Collector-emitter saturation voltage	V _{CE(sat)}	I _F =20mA, I _C =1mA	-	0.2	V
Current Transfer Ratio	CTR	I _F =5mA, V _{CE} =5V	50	400	%

Reliability criteria

1. Reading value for each step test not over 50% Delta for V_F, BV_{CEO}, BV_{ECO} and I_C parameter.
2. Reading value for each step test not over spec limit for I_R, I_{CEO} and V_{CE(sat)} parameter.
3. Short and open is criteria of Temperature cycling test and Autoclave test item.

5. Outgoing inspection

5.1 Inspection items

(1) Appearance

5.2 Sampling method and Inspection level

A single sampling plan, normal inspection level II based on ISO 2859 is applied.

The AQL according to the inspection items are shown below.

Defect	Inspection item	AQL (%)
Major defect	Unreadable marking	0.15
Minor defect	Appearance defect except the above mentioned.	0.65

6.2 Packing specification

6.2.1 Package materials

Name	Materials
Reel	PS
Packing case (Inner box)	Paper
Packing case (Outer carton)	

6.2.2 Packing quantity

Reel volume (pcs/Reel)	Inner box volume (Reel/Box)	Outer carton volume (Box/Carton)	Total volume (pcs/outer carton)
2000	2	10	40000

6.2.3 Carrier tape structure and dimensions

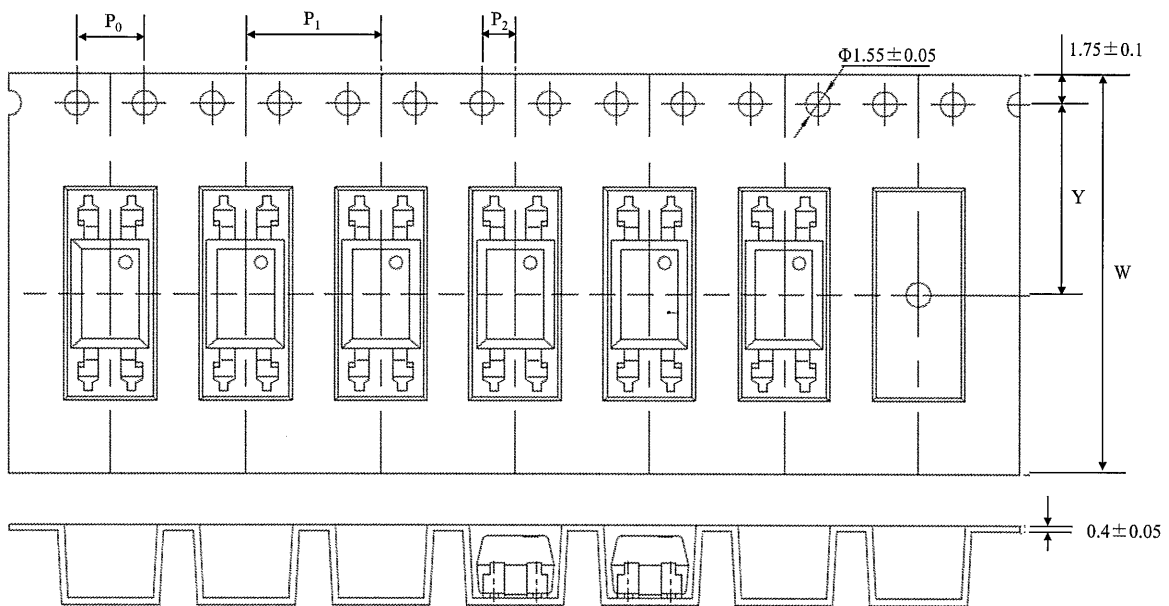

• Dimensions list (Unit : mm)

W	P ₀	P ₁	P ₂	Y
24.0±0.3	4.0±0.1	8.0±0.1	2.0±0.1	11.5±0.1

6.2.4 Reel structure and dimensions

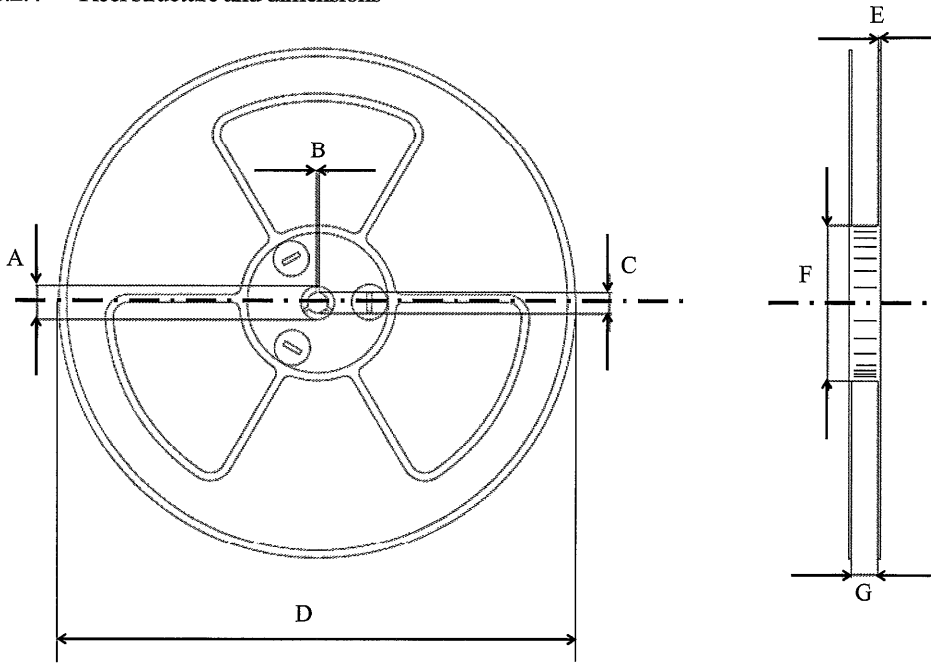

• Dimensions list (Unit : mm)

A	B	C	D	E	F	G
21±0.8	2.0±0.5	13.0 ^{+0.5} _{-0.2}	φ 330±2	1.8 ^{+0.2} ₋₀	100±0.5	24.4 ^{+0.2} ₋₀

6.2.5 Direction of product insertion

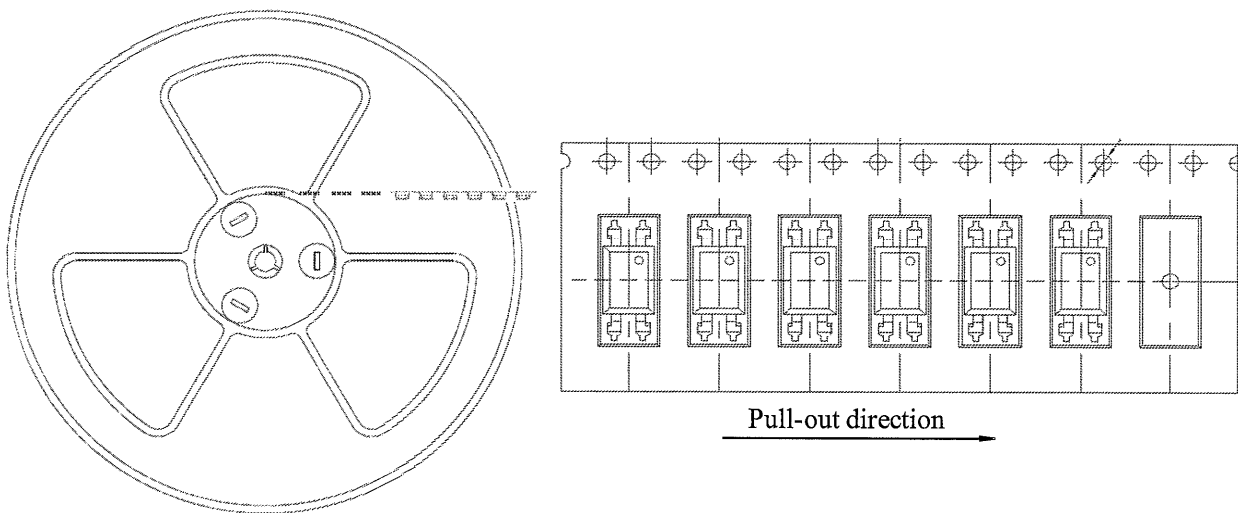

6.2.6 Outer packing appearance

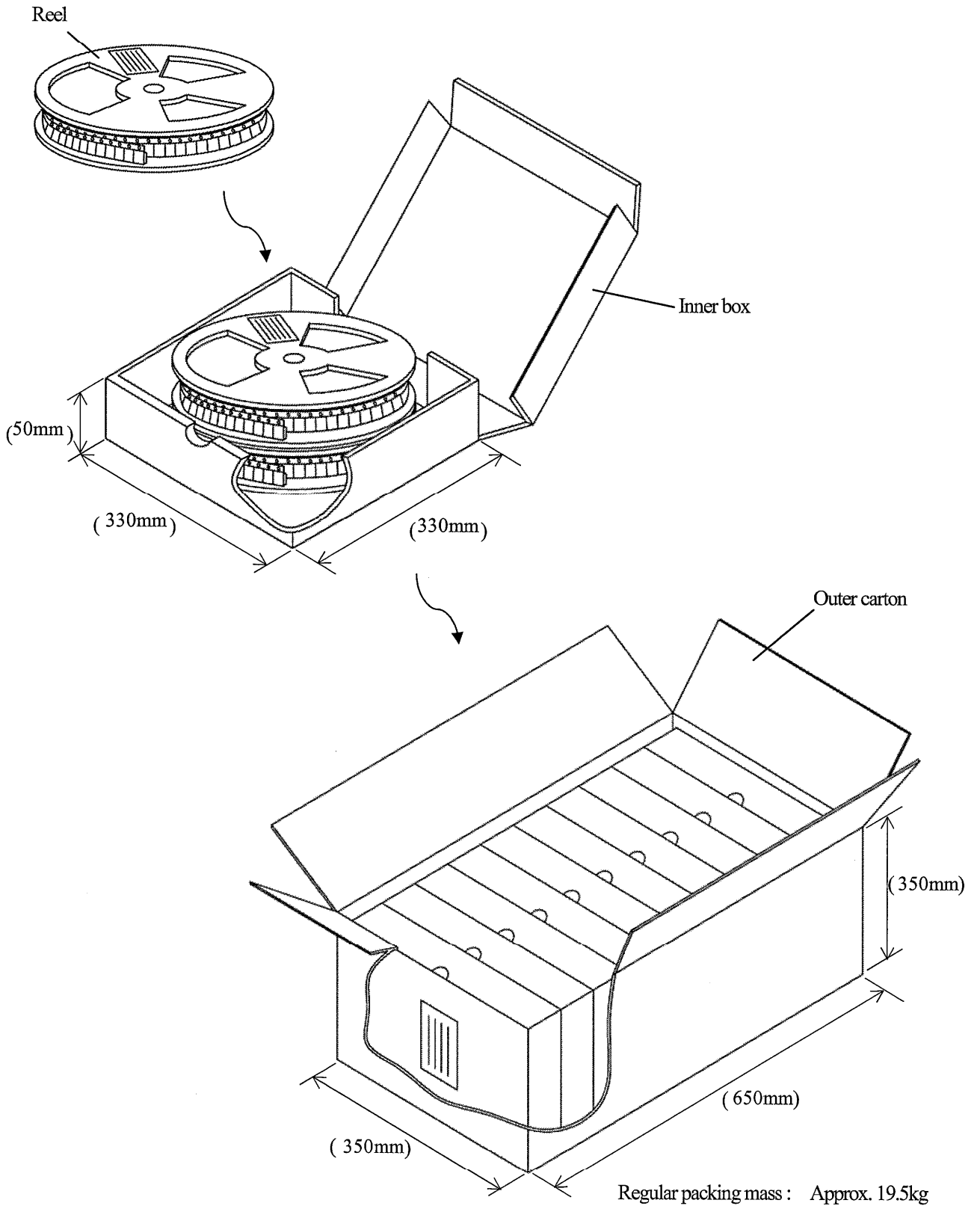

() : Reference dimensions

Precautions for Photocouplers

1 Cleaning

- (1) Solvent cleaning : Solvent temperature 45°C or less
Immersion for 3 min or less
- (2) Ultrasonic cleaning : The effect to device by ultrasonic cleaning differs by cleaning bath size, ultrasonic power output, cleaning time, PCB size or device mounting condition etc. Please test it in actual using condition and confirm that any defect doesn't occur before starting the ultrasonic cleaning.
- (3) Applicable solvent : Ethyl alcohol, Methyl alcohol, Isopropyl alcohol
When the other solvent is used, there are cases that the packaging resin is eroded.
Please use the other solvent after thorough confirmation is performed in actual using condition.

2. Circuit design

- 2.1 The LED used in the Photocoupler generally decreases the light emission power by operation. In case of long operation time, please design the circuit in consideration of the degradation of the light emission power of the LED. (50%/5years)
- 2.2 There are cases that the deviation of the CTR and the degradation of the relative light emission power of the LED increase when the setting value of I_F is less than 1.0mA. Please design the circuit in consideration of this point.

3. Precautions for Soldering

- (1) In the case of flow soldering (Avoid immersing units body in the solder)
One time soldering is recommended within the condition of temperature.
Temperature: $260+0/-5^{\circ}\text{C}$
Time: 10 s.
Preheat temperature: 25 to 140°C
Preheat time: 30 to 80 s

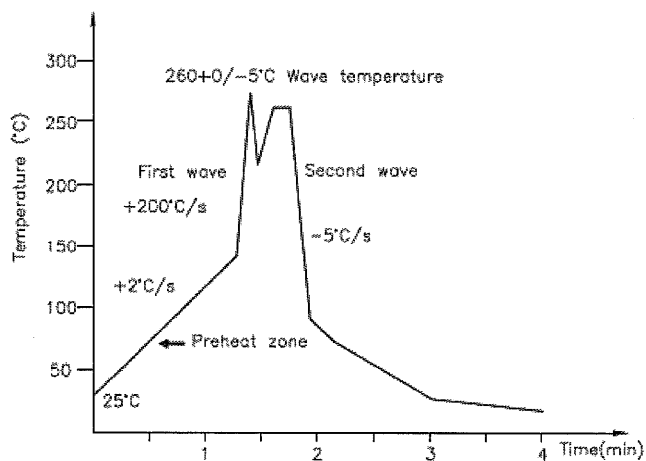

REFERENCE

(2) In the case of IR Reflow soldering

One time soldering reflow is recommended within the condition of temperature and time profile shown below.

Profile item	Conditions
Preheat <ul style="list-style-type: none"> ▪ Temperature Min (T_{smin}) ▪ Temperature Max (T_{smax}) ▪ Time (Min to Max) (ts) 	150°C 200°C 90±30 s
Soldering zone <ul style="list-style-type: none"> ▪ Temperature (T_L) ▪ Time (t_L) 	217°C 60 s
Peak Temperature (T_p)	260°C
Ramp-up rate	3°C/s (Max)
Ramp-down rate	3~6°C/s

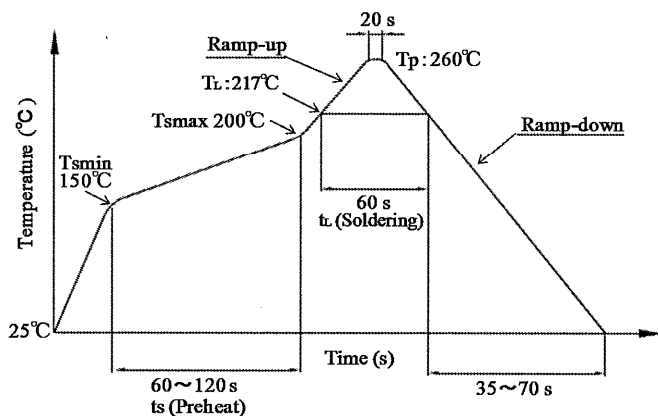

(3) In the case of hand soldering by soldering iron

Allow single lead soldering in every single process. One time soldering is recommended.

Temperature: 380+0/-5°C

Time: (max.) 3s

(4) The form of a lead tip part

There is production tolerance as shown in the following figure



(5) Other precautions

- Avoid immersing units body in the solder
- Depending on equipment and soldering conditions (temperature, Using solder etc.), the effect to the device and the PCB is different.

Please confirm that there is no problem on the actual use conditions in advance.

Looking for pricing, stock, or lifecycle information?

Click below to explore more details on WIN SOURCE:

- ⊖ [View PC123Y23FP9F on WIN SOURCE](#)
- ⊖ [Sharp Microelectronics Information](#)

Optimize Your Supply Chain with WIN SOURCE Solutions

- ✓ Global Sourcing Solution
- ✓ Obsolete Management
- ✓ Cost Control Management
- ✓ Shortage Management
- ✓ Alternative Solution
- ✓ Excess Inventory Management