

# SPOC - BTS5662E

SPI Power Controller

Automotive Power



Never stop thinking

## Table of Contents

<b>1</b>	<b>Overview</b> .....	<b>3</b>
<b>2</b>	<b>Block Diagram</b> .....	<b>5</b>
2.1	Terms .....	6
<b>3</b>	<b>Pin Configuration</b> .....	<b>7</b>
3.1	Pin Assignment SPOC - BTS5662E .....	7
3.2	Pin Definitions and Functions .....	8
<b>4</b>	<b>Electrical Characteristics</b> .....	<b>9</b>
4.1	Absolute Maximum Ratings .....	9
4.2	Thermal Resistance .....	10
<b>5</b>	<b>Power Supply</b> .....	<b>11</b>
5.1	Power Supply Modes .....	11
5.2	Reset .....	12
5.3	Electrical Characteristics .....	13
5.4	Command Description .....	14
<b>6</b>	<b>Power Stages</b> .....	<b>15</b>
6.1	Output ON-State Resistance .....	15
6.2	Input Circuit .....	15
6.3	Power Stage Output .....	16
6.4	Electrical Characteristics .....	18
6.5	Command Description .....	20
<b>7</b>	<b>Protection Functions</b> .....	<b>21</b>
7.1	Over Load Protection .....	21
7.2	Over Temperature Protection .....	22
7.3	Reverse Polarity Protection .....	23
7.4	Over Voltage Protection .....	24
7.5	Loss of Ground .....	24
7.6	Loss of $V_{BB}$ .....	24
7.7	Electrical Characteristics .....	25
7.8	Command Description .....	26
<b>8</b>	<b>Diagnosis</b> .....	<b>27</b>
8.1	Diagnosis Word at SPI .....	28
8.2	Load Current Sense Diagnosis .....	29
8.3	Switch Bypass Diagnosis .....	31
8.4	Electrical Characteristics .....	32
8.5	Command Description .....	34
<b>9</b>	<b>Serial Peripheral Interface (SPI)</b> .....	<b>36</b>
9.1	SPI Signal Description .....	36
9.2	Daisy Chain Capability .....	37
9.3	Timing Diagrams .....	38
9.4	Electrical Characteristics .....	38
9.5	SPI Protocol .....	40
9.6	Register Overview .....	41
<b>10</b>	<b>Application Description</b> .....	<b>42</b>
<b>11</b>	<b>Package Outlines SPOC - BTS5662E</b> .....	<b>43</b>
<b>12</b>	<b>Revision History</b> .....	<b>44</b>

**for Advanced Light Control**

# 1 Overview

**Features**

- 8 bit serial peripheral interface (daisy chain capable SPI) for control and diagnosis
- CMOS compatible parallel input pins for each channel provide direct PWM operation
- Selectable AND- / OR-combination for parallel inputs (PWM control)
- Very low stand-by current
- Enhanced electromagnetic compatibility (EMC)
- Stable behavior at under voltage
- Device ground independent from load ground
- Green Product (RoHS-Compliant)
- AEC Qualified

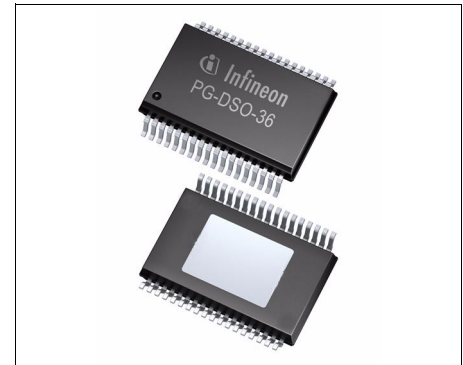

PG-DSO-36-36

**Description**

The SPOC - BTS5662E is a six channel high-side smart power switch in PG-DSO-36-36 package providing embedded protective functions. It is specially designed to control standard exterior lighting in automotive applications.

It is designed to drive lamps up to 3\*27W + 2\*10W + 5W.

**Product Summary**

Operating Voltage Power Switch	$V_{BB}$	5.5 ... 28 V
Logic Supply Voltage	$V_{DD}$	3.8 ... 5.5 V
Over Voltage Protection	$V_{BB(AZ,min)}$	40 V
Maximum Stand-By Current at 25 °C	$I_{BB(OFF)}$	3 $\mu$ A
Maximum On-state Resistance at $T_j = 150$ °C	$R_{DS(ON,max)}$	channel 0, 1, 2 100 m $\Omega$
		channel 3, 4 260 m $\Omega$
		channel 5 460 m $\Omega$
SPI Access Frequency	$f_{SCLK(max)}$	2 MHz

Type	Package	Marking
SPOC - BTS5662E	PG-DSO-36-36	BTS5662E

Configuration and status diagnosis are done via SPI. An 8 bit serial peripheral interface (SPI) is used. The SPI can be used in daisy chain configuration.

The device provides a current sense signal per channel that is multiplexed to the diagnosis pin IS. It can be enabled and disabled via SPI commands. An over load and over temperature flag is provided in the SPI diagnosis word. A multiplexed switch bypass monitor provides short-circuit to  $V_{BB}$  diagnosis.

The SPOC - BTS5662E provides a fail-safe feature via a limp home input pin.

The power transistors are built by N-channel vertical power MOSFETs with charge pumps. The device is monolithically integrated in SMART technology.

### Protective Functions

- Reverse battery protection with external components
- Short circuit protection
- Overload protection
- Multi step current limitation
- Thermal shutdown with latch and dynamic temperature sensor
- Overvoltage protection
- Loss of ground protection
- Electrostatic discharge protection (ESD)

### Diagnostic Functions

- Multiplexed proportional load current sense signal (IS)
- Enable function for current sense signal configurable via SPI
- High accuracy of current sense signal at wide load current range
- Feedback on over temperature and over load via SPI
- Multiplexed switch bypass monitor provides short circuit to  $V_{BB}$  detection

### Application Specific Functions

- Fail-safe activation via LHI pin and control via input pins

### Applications

- High-side power switch for 12 V grounded loads in automotive applications
- Especially designed for standard exterior lighting like tail light, brake light, parking light, license plate light, indicators
- Replaces electromechanical relays, fuses and discrete circuits

## 2 Block Diagram

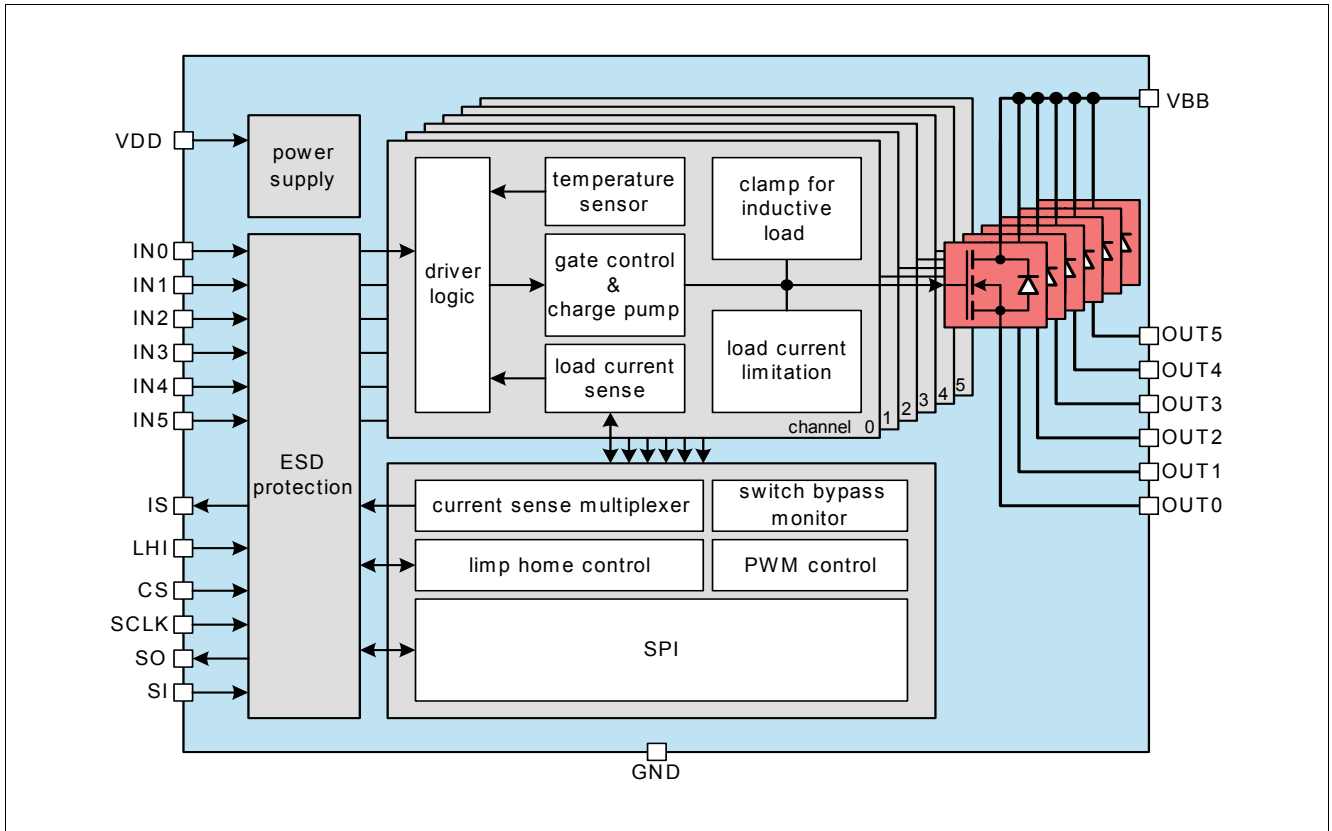
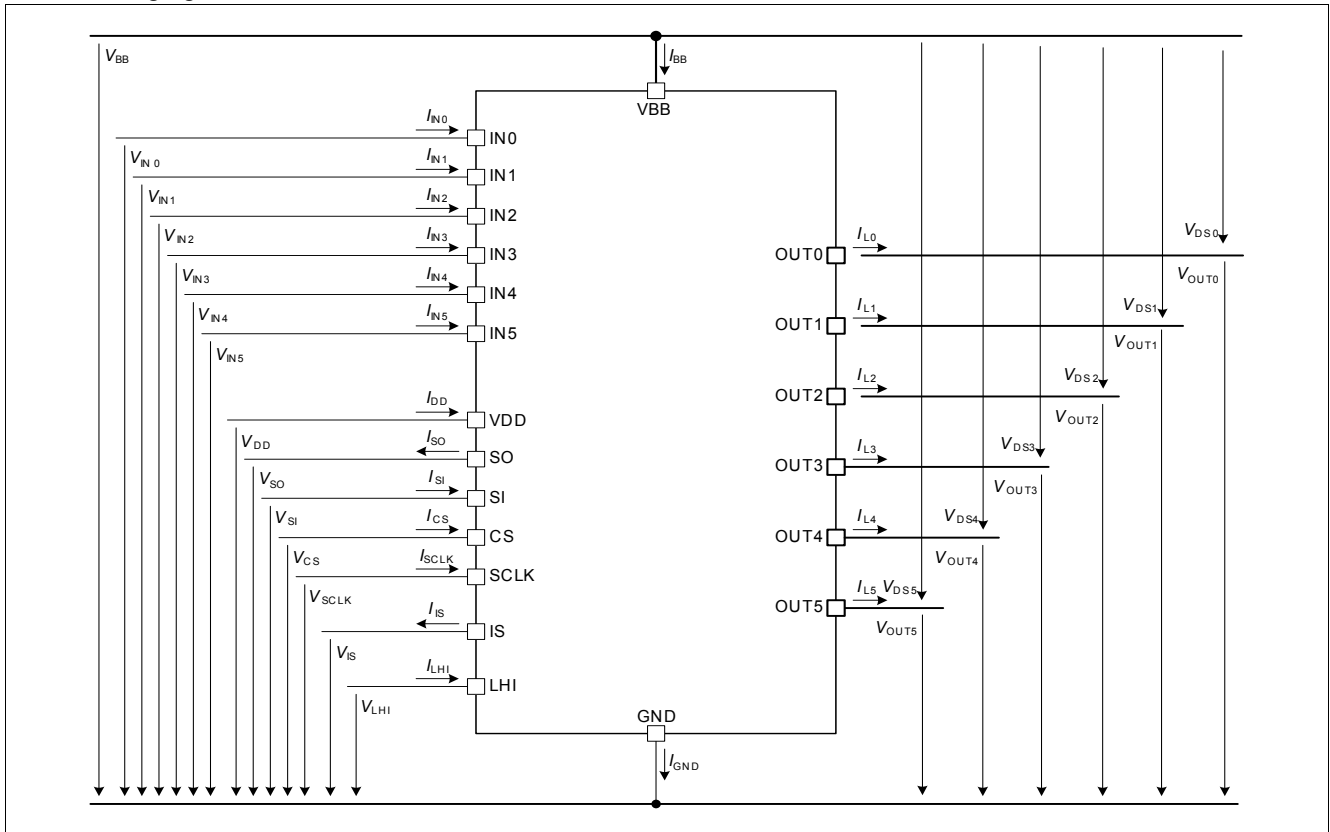

Figure 1 Block Diagram SPOC - BTS5662E

## 2.1 Terms

The following figure shows all terms used in this data sheet.



**Figure 2** Terms

In all tables of electrical characteristics is valid: Channel related symbols without channel number are valid for each channel separately (e.g.  $V_{DS}$  specification is valid for  $V_{DS0} \dots V_{DS5}$ ).

All SPI register bits are marked as follows: ADDR.PARAMETER (e.g. HWCR.CTL). In SPI register description, the values in bold letters (e.g. **0**) are default values.

### 3 Pin Configuration

#### 3.1 Pin Assignment SPOC - BTS5662E

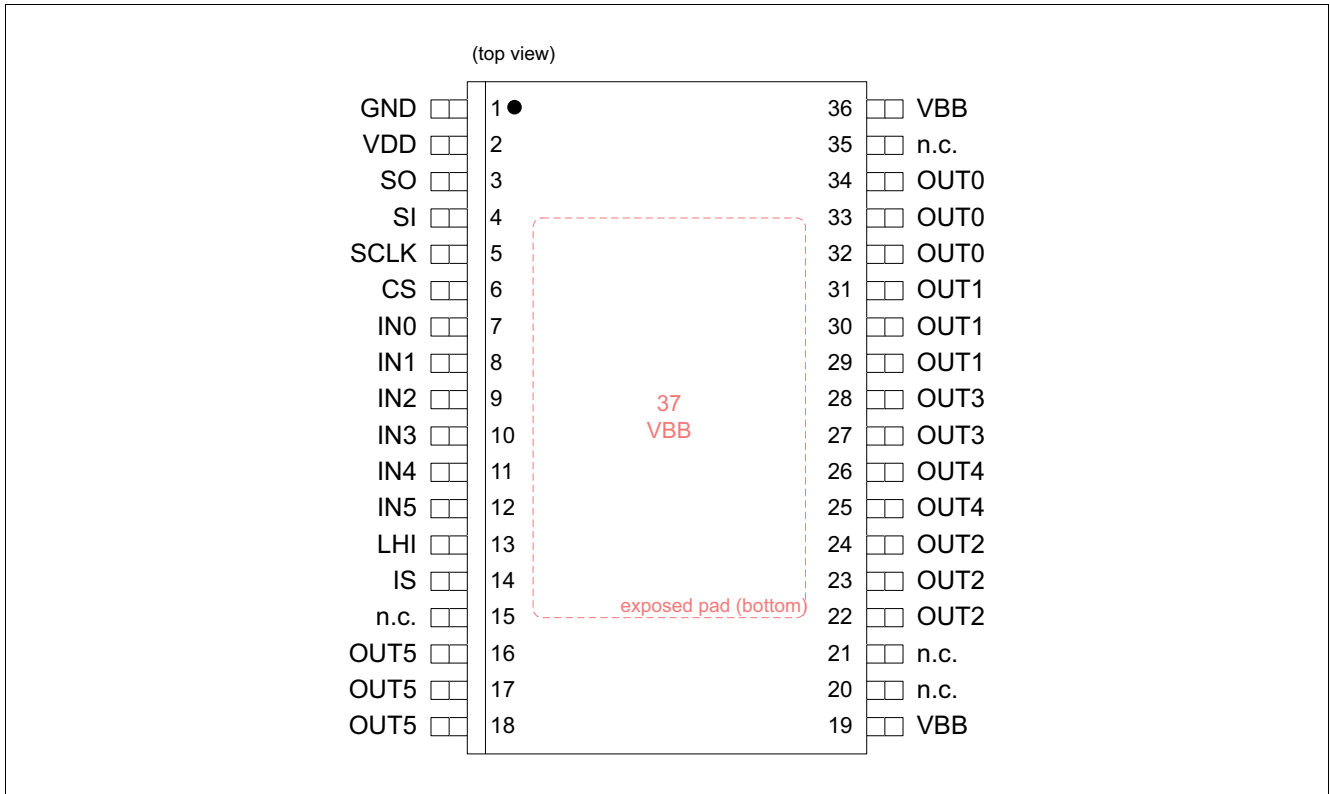

Figure 3 Pin Configuration PG-DSO-36-36

### 3.2 Pin Definitions and Functions

Pin	Symbol	I/O	Function
<b>Power Supply Pins</b>			
19, 36, 37 <sup>1)</sup>	VBB	–	Positive power supply for high-side power switch
2	VDD	–	Logic supply (5 V)
1	GND	–	Ground connection
<b>Parallel Input Pins (integrated pull-down, leave unused input pins unconnected)</b>			
7	IN0	I	Input signal of channel 0
8	IN1	I	Input signal of channel 1
9	IN2	I	Input signal of channel 2
10	IN3	I	Input signal of channel 3
11	IN4	I	Input signal of channel 4
12	IN5	I	Input signal of channel 5
<b>Power Output Pins</b>			
32, 33, 34 <sup>2)</sup>	OUT0	O	Protected high-side power output of channel 0
29, 30, 31 <sup>2)</sup>	OUT1	O	Protected high-side power output of channel 1
22, 23, 24 <sup>2)</sup>	OUT2	O	Protected high-side power output of channel 2
27, 28 <sup>2)</sup>	OUT3	O	Protected high-side power output of channel 3
25, 26 <sup>2)</sup>	OUT4	O	Protected high-side power output of channel 4
16, 17, 18 <sup>2)</sup>	OUT5	O	Protected high-side power output of channel 5
<b>SPI &amp; Diagnosis Pins</b>			
6	CS	I	Chip select of SPI interface (low active), Integrated pull up
5	SCLK	I	Serial clock of SPI interface
4	SI	I	Serial input of SPI interface
3	SO	O	Serial output of SPI interface
14	IS	O	Diagnosis output signal
<b>Limp Home Pin (integrated pull-down, leave unused limp home pin unconnected)</b>			
13	LHI	I	Limp home activation signal; Active high
<b>Not connected Pin</b>			
15, 20, 21, 35	n.c.	–	not connected, internally not bonded

1) The exposed pad (pin 37) has to be connected to the power supply with a low impedance connection. The exposed pad must be connected with a low thermal resistance.

2) All outputs pins of each channel have to be connected.

## 4 Electrical Characteristics

### 4.1 Absolute Maximum Ratings

#### Absolute Maximum Ratings <sup>1)</sup>

$T_j = -40\text{ °C}$  to  $+150\text{ °C}$ ; all voltages with respect to ground  
(unless otherwise specified)

Pos.	Parameter	Symbol	Limit Values		Unit	Conditions
			min.	max.		
<b>Supply Voltage</b>						
4.1.1	Power supply voltage	$V_{BB}$	-0.3	28	V	–
4.1.2	Logic supply voltage	$V_{DD}$	-0.3	5.5	V	–
4.1.3	Reverse polarity voltage according <b>Figure 23</b>	$-V_{bat(rev)}$	–	16	V	$T_{j(Start)} = 25\text{ °C}$ $t \leq 2\text{ min.}$ <sup>2)</sup>
4.1.4	Supply voltage for full short circuit protection (single pulse) ( $T_{j(0)} = -40\text{ °C} \dots 150\text{ °C}$ )	$V_{BB(SC)}$	0	20	V	$R_{ECU} = 20\text{m}\Omega$ $R_{Cable} = 16\text{m}\Omega/\text{m}$ $L_{Cable} = 1\mu\text{H}/\text{m}$ $l = 0\text{ or }5\text{m}$ <sup>3)</sup>
4.1.5	Voltage at power transistor	$V_{DS}$	–	40	V	–
4.1.6	Supply voltage for load dump protection	$V_{BB(LD)}$	–	40	V	$R_l = 2\text{ }\Omega$ <sup>4)</sup> $t = 400\text{ms}$
4.1.7	Current through ground pin	$I_{GND}$	-100	25	mA	$t \leq 2\text{ min.}$
4.1.8	Current through $V_{DD}$ pin	$I_{DD}$	-25	12	mA	$t \leq 2\text{ min.}$
<b>Power Stages</b>						
4.1.9	Load current	$I_L$	$-I_{L(LIM)}$	$I_{L(LIM)}$	A	<sup>5)</sup>
<b>Diagnosis Pin</b>						
4.1.10	Current through sense pin IS	$I_{IS}$	-10	10	mA	$t \leq 2\text{ min.}$
<b>Input Pins</b>						
4.1.11	Voltage at input pins	$V_{IN}$	-0.3	8.0	V	–
4.1.12	Current through input pins	$I_{IN}$	-0.75 -2.0	0.75 2.0	mA	– $t \leq 2\text{ min.}$
<b>SPI Pins</b>						
4.1.13	Voltage at chip select pin	$V_{CS}$	-0.3	5.7	V	–
4.1.14	Current through chip select pin	$I_{CS}$	-0.75 -2.0	0.75 2.0	mA	– $t \leq 2\text{ min.}$
4.1.15	Voltage at serial input pin	$V_{SI}$	-0.3	5.7	V	–
4.1.16	Current through serial input pin	$I_{SI}$	-0.75 -2.0	0.75 2.0	mA	– $t \leq 2\text{ min.}$
4.1.17	Voltage at serial clock pin	$V_{SCLK}$	-0.3	5.7	V	–
4.1.18	Current through serial clock pin	$I_{SCLK}$	-0.75 -2.0	0.75 2.0	mA	– $t \leq 2\text{ min.}$
4.1.19	Current through serial output pin SO	$I_{SO}$	-0.75 -2.0	0.75 2.0	mA	– $t \leq 2\text{ min.}$
<b>Limp Home Pin</b>						
4.1.20	Voltage at limp home input pin	$V_{LHI}$	-0.3	8.0	V	–

**Electrical Characteristics**
**Absolute Maximum Ratings (cont'd)<sup>1)</sup>**

$T_j = -40\text{ °C to }+150\text{ °C}$ ; all voltages with respect to ground  
(unless otherwise specified)

Pos.	Parameter	Symbol	Limit Values		Unit	Conditions
			min.	max.		
4.1.21	Current through limp home input pin	$I_{LHI}$	-0.75 -2.0	0.75 2.0	mA	– $t \leq 2\text{ min.}$

**Temperatures**

4.1.22	Junction temperature	$T_j$	-40	150	°C	–
4.1.23	Dynamic temperature increase while switching	$\Delta T_j$	–	60	K	–
4.1.24	Storage temperature	$T_{stg}$	-55	150	°C	–

**ESD Susceptibility**

4.1.25	ESD resistivity  OUT pins vs. VBB other pins incl. OUT vs. GND	$V_{ESD}$			kV	HBM <sup>6)</sup>	
			-4	4			–
			-2	2			–

- 1) Not subject to production test, specified by design.
- 2) Device mounted on a FR4 2s2p board according to Jedec JESD51-2,-5,-7 at natural convection; The product (chip+package) was simulated on a 76.4 x 114.3 x 1.5 mm board with 2 inner copper layers (2 x 70µm Cu, 2 x 35µm Cu). Where applicable, a thermal via array under the package contacted the first inner copper layer.
- 3) In accordance to AEC Q100-012 and AEC Q101-006.
- 4)  $R_i$  is the internal resistance of the load dump pulse generator.
- 5) Current limitation is a protection feature. Operation in current limitation is considered as “outside” normal operating range. Protection features are not designed for continuous repetitive operation.
- 6) ESD resistivity, HBM according to EIA/JESD 22-A 114B (1.5kΩ, 100pF).

*Note: Stresses above the ones listed here may cause permanent damage to the device. Exposure to absolute maximum rating conditions for extended periods may affect device reliability.*

*Note: Integrated protection functions are designed to prevent IC destruction under fault conditions described in the data sheet. Fault conditions are considered as “outside” normal operating range. Protection functions are not designed for continuous repetitive operation.*

**4.2 Thermal Resistance**

Pos.	Parameter	Symbol	Limit Values			Unit	Conditions
			Min.	Typ.	Max.		
4.2.1	Junction to Case <sup>1)</sup>	$R_{thJC}$	–	–	2	K/W	–
4.2.2	Junction to Ambient <sup>1)</sup>	$R_{thJA}$	–	22	–	K/W	<sup>2)</sup>

- 1) Not subject to production test, specified by design.
- 2) Device mounted on a FR4 2s2p board according to Jedec JESD51-2,-5,-7 at natural convection; The product (chip+package) was simulated on a 76.4 x 114.3 x 1.5 mm board with 2 inner copper layers (2 x 70µm Cu, 2 x 35µm Cu). Where applicable, a thermal via array under the package contacted the first inner copper layer.

## 5 Power Supply

The SPOC - BTS5662E is supplied by two supply voltages  $V_{BB}$  and  $V_{DD}$ . The  $V_{BB}$  supply line is used by the power switches. The  $V_{DD}$  supply line is used by the SPI related circuitry and for driving the SO line. A capacitor between pins VDD and GND is recommended as shown in [Figure 23](#).

There is a power-on reset function implemented for the  $V_{DD}$  logic power supply. After start-up of the logic power supply, all SPI registers are reset to their default values. The SPI interface including daisy chain function is active as soon as  $V_{DD}$  is provided in the specified range independent of  $V_{BB}$ . The first SPI transmission after a reset contains at pin SO the read information from register `OUT`, the transmission error bit `TER` is set.

### 5.1 Power Supply Modes

The following table shows all possible power supply modes for  $V_{BB}$ ,  $V_{DD}$  and the pin LHI.

Power Supply Modes	Off	Off	SPI on	Reset	Off	Limp Home mode without SPI	Normal operation	Limp Home mode with SPI <sup>1)</sup>
$V_{BB}$	0 V	0 V	0 V	0 V	13.5 V	13.5 V	13.5 V	13.5 V
$V_{DD}$	0 V	0 V	5 V	5 V	0 V	0 V	5 V	5 V
LHI	0 V	5 V	0 V	5 V	0 V	5 V	0 V	5 V
PROFET operating	–	–	–	–	–	✓	✓	✓
Limp home	–	–	–	–	–	✓	–	✓
SPI (logic)	–	–	✓	reset	reset	reset	✓	reset
Stand-by current	–	–	–	–	✓	–	✓ <sup>2)</sup>	–
Idle current	–	–	–	–	–	–	✓ <sup>3)</sup>	–
Diagnosis	–	–	–	–	–	–	✓	✓ <sup>4)</sup>

1) SPI read only.

2) When `DCR.MUX = 111b`.

3) When all channels are in OFF-state and `DCR.MUX != 111b`.

4) Current sense disabled in limp home mode.

Stand-by mode is entered as soon as the current sense multiplexer (`DCR.MUX`) is in default (stand-by) position <sup>1)</sup>. Additionally, all thermal latches are cleared automatically. As soon as stand-by mode is entered, register `HWCR.STB` is set. To wake-up the device, the current sense multiplexer (`DCR.MUX`) is programmed different to default (stand-by) position.

Idle mode parameters are valid, when all channels are switched off, but the current sense multiplexer is not in default position, and  $V_{DD}$  supply is available.

Limp home (LHI = high) will wake-up the device and is working without  $V_{DD}$  supply. As a result, all channels can be activated via the dedicated input pins.

1) Not affected by the inputs state

## 5.2 Reset

There are several reset triggers implemented in the device. They reset the SPI registers and errors flags to their default values. The power stages are not affected by the reset signals.

The first SPI transmission after any kind of reset contains at pin SO the read information from register `OUT`, the transmission error bit `TER` is set.

### Power-On Reset

The power-on reset is released, when  $V_{DD}$  voltage level is higher than  $V_{DD(min)}$ . The SPI interface can be accessed after wake up time  $t_{WU(PO)}$ .

### Reset Command

There is a reset command available to reset all register bits of the register bank and the diagnosis registers. As soon as `HWCR.RST = 1`, a reset is triggered equivalent to power-on reset. The SPI interface can be accessed after transfer delay time  $t_{CS(td)}$ .

### Limp Home Mode

In Limp Home mode, the SPI write-registers are reset. Output `OUTx` will follow the input `INx` configuration only. For application example see [Figure 23](#). The SPI interface is operating normally, so the limp home register bit `LHI` as well as the error flags can be read, but any write command will be ignored. To activate the Limp Home mode, `LHI` input pin voltage must be higher than  $V_{LHI(H)}$ .

### 5.3 Electrical Characteristics

#### Electrical Characteristics Power Supply

Unless otherwise specified:  $V_{BB} = 9\text{ V to }16\text{ V}$ ,  $V_{DD} = 3.8\text{ V to }5.5\text{ V}$ ,  $T_j = -40\text{ °C to }+150\text{ °C}$   
 typical values:  $V_{BB} = 13.5\text{ V}$ ,  $V_{DD} = 4.3\text{ V}$ ,  $T_j = 25\text{ °C}$

Pos.	Parameter	Symbol	Limit Values			Unit	Test Conditions
			min.	typ.	max.		
5.3.1	Operating voltage power switch	$V_{BB}$	5.5	–	28 <sup>1)</sup>	V	–
5.3.2	Stand-by current for whole device with loads	$I_{BB(STB)}$	–	0.5	3	$\mu\text{A}$	$V_{DD} = 0\text{ V}$ $V_{LHI} = 0\text{ V}$ $T_j = 25\text{ °C}$ $T_j \leq 85\text{ °C }^1)$ $T_j = 150\text{ °C}$
5.3.3	Idle current for whole device with loads, all channels off.	$I_{BB(idle)}$	–	3	8	mA	$V_{DD} = 5\text{ V}$ DCR.MUX = 110 <sub>B</sub>
5.3.4	Logic supply voltage	$V_{DD}$	3.8	–	5.5	V	–
5.3.5	Logic supply current	$I_{DD}$	–	55	120	$\mu\text{A}$	$V_{CS} = 0\text{ V}$ $f_{SCLK} = 0\text{ Hz}$
5.3.6	Logic idle current	$I_{DD(idle)}$	–	20	50	$\mu\text{A}$	$V_{CS} = V_{DD}$ $f_{SCLK} = 0\text{ Hz}$ Chip in Standby
5.3.7	Operating current for whole device	$I_{GND}$	–	12	25	mA	$f_{SCLK} = 0\text{ Hz}$
<b>LHI Input Characteristics</b>							
5.3.8	L-input level at pin LHI	$V_{LHI(L)}$	-0.3	–	1.0	V	–
5.3.9	H-input level at pin LHI	$V_{LHI(H)}$	2.6	–	5.5	V	–
5.3.10	L-input current through pin LHI	$I_{LHI(L)}$	3	–	85	$\mu\text{A}$	$V_{LHI} = 0.4\text{ V}$
5.3.11	H-input current through pin LHI	$I_{LHI(H)}$	7	30	85	$\mu\text{A}$	$V_{LHI} = 5\text{ V}$

1) Not subject to production test, specified by design.

*Note: Characteristics show the deviation of parameter at the given supply voltage and junction temperature.*

*Typical values show the typical parameters expected from manufacturing at  $V_{BB} = 13.5\text{ V}$ ,  $V_{DD} = 4.3\text{ V}$  and  $T_j = 25\text{ °C}$ .*

## 5.4 Command Description

### HWCR

#### Hardware Configuration Register

$W/\bar{R}^{1)}$	$RB^{1)}$	$ADDR^{1)}$	3	2	1	0
read	1	1	0	0	X	STB CTL
write	1	1	0	0	0	RST CTL

1)  $W/\bar{R}$  Write/Read, RB Register Bank, ADDR Address

Field	Bits	Type	Description
RST	1	w	<b>Reset Command</b> 0 Normal operation 1 Execute reset command
STB	1	r	<b>Stand-by</b> 0 Device is awake 1 Device is in stand-by mode

## 6 Power Stages

The high-side power stages are built by N-channel vertical power MOSFETs (DMOS) with charge pumps. There are six channels implemented in the device. Each channel can be switched on via an input pin or via SPI register OUT.

### 6.1 Output ON-State Resistance

The on-state resistance  $R_{DS(ON)}$  depends on the supply voltage  $V_{BB}$  as well as on the junction temperature  $T_j$ . **Figure 4** shows those dependencies. The behavior in reverse polarity mode is described in **Section 12**.

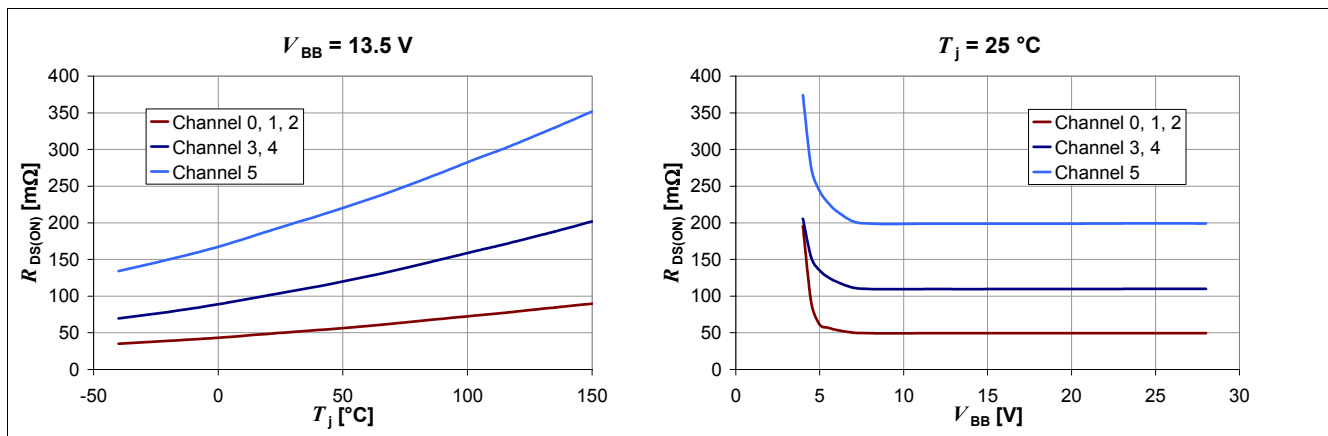

Figure 4 Typical On-State Resistance

### 6.2 Input Circuit

There are two ways of using the input pins in combination with the OUT register by programming the `HWCR.PWM` parameter.

- `PCR.PWM = 0`: A channel is switched on either by the according OUT register bit or the input pin.
- `PCR.PWM = 1`: A channel is switched on by the according OUT register bit only, when the input pin is high. In this configuration, a PWM signal can be given to the input pin and the channel is activated by the SPI register OUT.

**Figure 5** shows the complete input switch matrix.

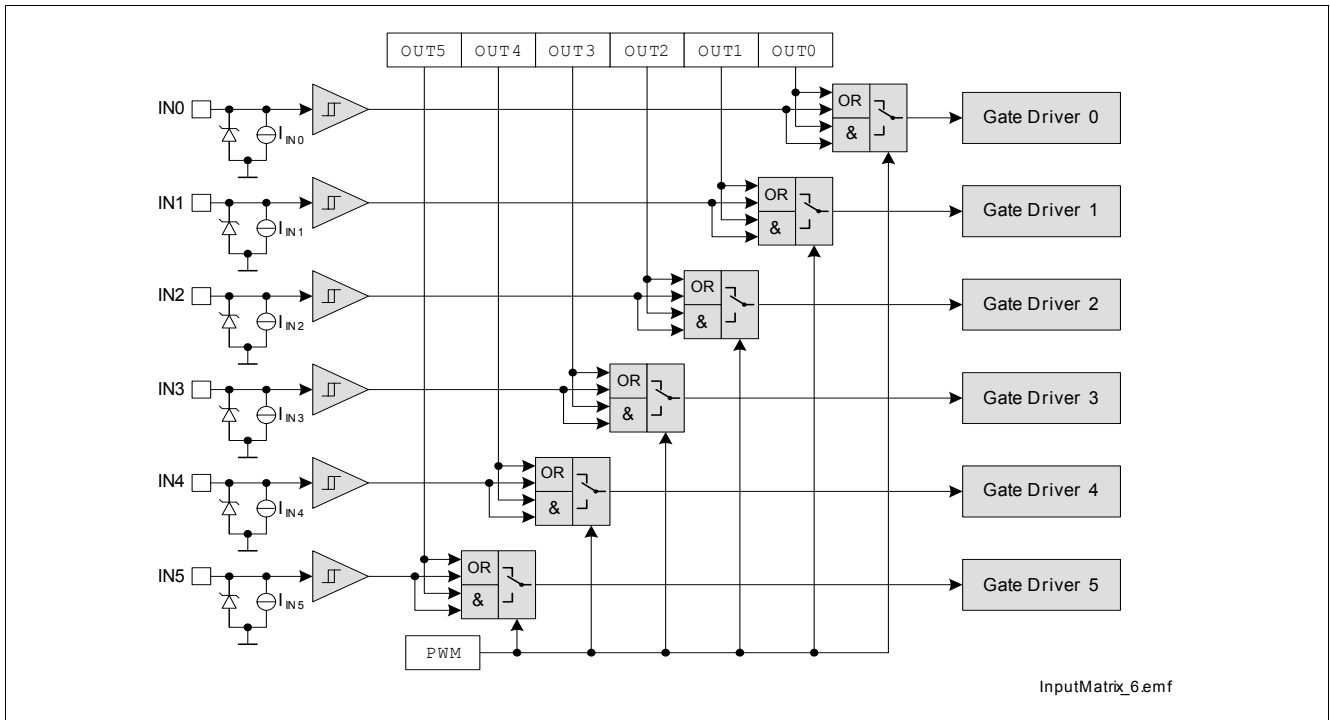
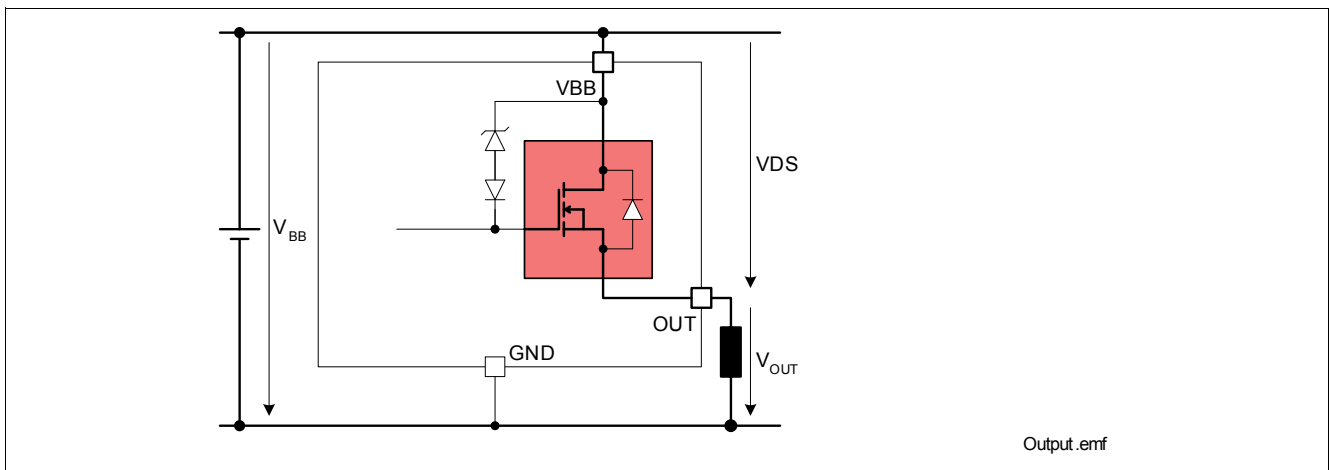

**Figure 5 Input Switch Matrix**

The current sink to ground ensures that the input signal is low in case of an open input pin. The zener diode protects the input circuit against ESD pulses.

### 6.3 Power Stage Output

The power stages are built to be used in high side configuration (Figure 6).



**Figure 6 Power Stage Output**

The power DMOS switches with a dedicated slope, which is optimized in terms of EMC emission.

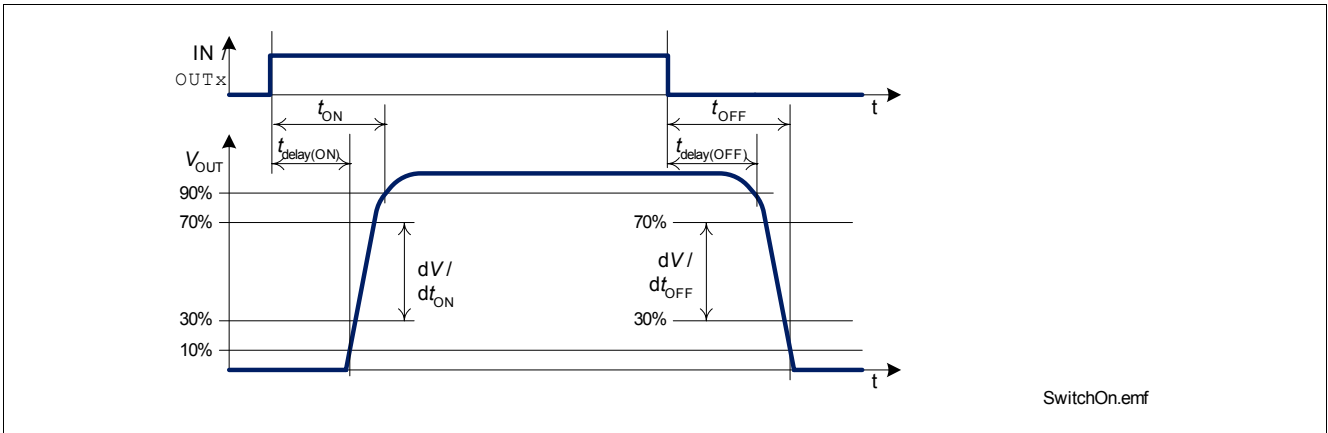

**Figure 7 Switching a Load (resistive)**

When switching off inductive loads with high-side switches, the voltage  $V_{OUT}$  drops below ground potential, because the inductance intends to continue driving the current. To prevent avalanche of the device, there is a voltage clamp mechanism implemented which limits that negative output voltage to a certain level ( $V_{DS(CL)}$ ). See [Figure 6](#) for details. The maximum allowed load inductance is limited.

## 6.4 Electrical Characteristics

### Electrical Characteristics Power Stages

Unless otherwise specified:  $V_{BB} = 9\text{ V to }16\text{ V}$ ,  $T_j = -40\text{ °C to }+150\text{ °C}$   
 typical values:  $V_{BB} = 13.5\text{ V}$ ,  $T_j = 25\text{ °C}$

Pos.	Parameter	Symbol	Limit Values			Unit	Test Conditions				
			min.	typ.	max.						
<b>Output Characteristics</b>											
6.4.1	On-State Resistance	$R_{DS(ON)}$				mΩ	<sup>1)</sup> $T_j = 25\text{ °C} / I_L = 2.6\text{ A}$ $T_j = 150\text{ °C} / I_L = 2.6\text{ A}$ <sup>1)</sup> $T_j = 25\text{ °C} / I_L = 1.3\text{ A}$ $T_j = 150\text{ °C} / I_L = 1.3\text{ A}$ <sup>1)</sup> $T_j = 25\text{ °C} / I_L = 0.6\text{ A}$ $T_j = 150\text{ °C} / I_L = 0.6\text{ A}$				
								channel 0, 1, 2	–	50	–
									–	85	100
								channel 3, 4	–	110	–
									–	200	260
	channel 5	–	200	–							
		–	350	460							
6.4.2	Output voltage drop limitation at small load currents	$V_{DS(NL)}$				mV	$I_L = 35\text{ mA}$ $I_L = 35\text{ mA}$				
								channel 0, 1, 2	–	25	–
	channel 3, 4, 5	–	25	–							
6.4.3	Output clamp	$V_{DS(CL)}$	40	47	54	V	$I_L = 20\text{ mA}$ <sup>2)</sup>				
6.4.4	Output leakage current per channel	$I_{L(OFF)}$				μA	$V_{IN} = 0\text{ V}$ or floating $OUT. OUTn = 0$ stand-by idle stand-by idle stand-by idle				
								channel 0, 1, 2	–	0.1	10
									–	–	40
								channel 3, 4	–	0.1	8
									–	–	40
	channel 5	–	0.1	8							
		–	–	40							
6.4.5	Inverse current capability per channel	$-I_{L(IC)}$				A	<sup>3)</sup> – – –				
								channel 0, 1, 2	–	2.5	–
								channel 3, 4	–	1.0	–
								channel 5	–	0.5	–
<b>Input Characteristics</b>											
6.4.6	L-input level	$V_{IN(L)}$	-0.3	–	1.0	V	–				
6.4.7	H-input level	$V_{IN(H)}$	2.6	–	5.5	V	–				
6.4.8	L-input current	$I_{IN(L)}$	3	25	75	μA	$V_{IN} = 0.4\text{ V}$				
6.4.9	H-input current	$I_{IN(H)}$	10	40	75	μA	$V_{IN} = 5\text{ V}$				

**Electrical Characteristics Power Stages (cont'd)**

 Unless otherwise specified:  $V_{BB} = 9\text{ V to }16\text{ V}$ ,  $T_j = -40\text{ °C to }+150\text{ °C}$ 

 typical values:  $V_{BB} = 13.5\text{ V}$ ,  $T_j = 25\text{ °C}$ 

Pos.	Parameter	Symbol	Limit Values			Unit	Test Conditions		
			min.	typ.	max.				
<b>Timings</b>									
6.4.10	Turn-ON delay to 10% $V_{BB}$ (Logical propagation delay from input INx to output OUTx)	$t_{\text{delay(ON)}}$				$\mu\text{S}$	$V_{BB} = 13.5\text{ V}^{1)}$		
			channel 0, 1, 2	–	35			–	$R_L = 6.8\ \Omega$
			channel 3, 4	–	20			–	$R_L = 18\ \Omega$
			channel 5	–	30			–	$R_L = 33\ \Omega$
6.4.11	Turn-OFF delay to 90% $V_{BB}$ (Logical propagation delay from input INx to output OUTx)	$t_{\text{delay(OFF)}}$				$\mu\text{S}$	$V_{BB} = 13.5\text{ V}^{1)}$		
			channel 0, 1, 2	–	50			–	$R_L = 6.8\ \Omega$
			channel 3, 4	–	30			–	$R_L = 18\ \Omega$
			channel 5	–	40			–	$R_L = 33\ \Omega$
6.4.12	Turn-ON time to 90% $V_{BB}$	$t_{\text{ON}}$				$\mu\text{S}$	$V_{BB} = 13.5\text{ V}$		
			channel 0, 1, 2	–	–			250	$R_L = 6.8\ \Omega$
			channel 3, 4	–	–			150	$R_L = 18\ \Omega$
			channel 5	–	–			170	$R_L = 33\ \Omega$
6.4.13	Turn-OFF time to 10% $V_{BB}$	$t_{\text{OFF}}$				$\mu\text{S}$	$V_{BB} = 13.5\text{ V}$		
			channel 0, 1, 2	–	–			290	$R_L = 6.8\ \Omega$
			channel 3, 4	–	–			150	$R_L = 18\ \Omega$
			channel 5	–	–			170	$R_L = 33\ \Omega$
6.4.14	Turn-ON slew rate 30% to 70% $V_{BB}$	$dV/dt_{\text{ON}}$				$\text{V}/\mu\text{S}$	$V_{BB} = 13.5\text{ V}$		
			channel 0, 1, 2	0.1	0.2			0.5	$R_L = 6.8\ \Omega$
			channel 3, 4	0.1	0.45			0.9	$R_L = 18\ \Omega$
			channel 5	0.1	0.45			0.9	$R_L = 33\ \Omega$
6.4.15	Turn-OFF slew rate 70% to 30% $V_{BB}$	$-dV/dt_{\text{OFF}}$				$\text{V}/\mu\text{S}$	$V_{BB} = 13.5\text{ V}$		
			channel 0, 1, 2	0.1	0.2			0.5	$R_L = 6.8\ \Omega$
			channel 3, 4	0.1	0.45			0.9	$R_L = 18\ \Omega$
			channel 5	0.1	0.45			0.9	$R_L = 33\ \Omega$

1) Not subject to production test, specified by design.

2) The voltage increase until the current is reached.

 3) Not subject to production test, specified by design. In case of inverse current ( $V_{\text{OUT}} > V_{\text{BB}}$ ), the error flag `ERR` in the standard diagnosis of the affected channel is cleared (valid for channel 0, 1, 2, 3, 4). The inverse current capability in ON-state and OFF-state is defined for  $T_j < T_{j(\text{SC})}$  and channel remains in same state (ON-state or OFF-state). Other channels can be affected (e.g. OUT latch due to junction temperature increase).

## 6.5 Command Description

### OUT

#### Output Configuration Registers

	$\overline{W/R}$	RB	5	4	3	2	1	0
read/write		0	OUT5	OUT4	OUT3	OUT2	OUT1	OUT0

Field	Bits	Type	Description
OUTn n = 5 to 0	n	rw	<b>Set Output Mode for Channel n</b> 0 Channel n is switched off 1 Channel n is switched on

### PCR

#### PWM Register

	$\overline{W/R}$	RB	ADDR	3	2	1	0
read / write		1	0	1	PWM	X	X

Field	Bits	Type	Description
PWM	3	rw	<b>PWM Configuration</b> 0 Input signal OR-combined with according OUT register bit 1 Input signal AND-combined with according OUT register bit

## 7 Protection Functions

The device provides embedded protective functions, which are designed to prevent IC destruction under fault conditions described in this data sheet. Fault conditions are considered as “outside” normal operating range. Protective functions are neither designed for continuous nor for repetitive operation.

### 7.1 Over Load Protection

The load current  $I_L$  is limited by the device itself in case of over load or short circuit to ground. There are multiple steps of current limitation which are selected automatically depending on the voltage  $V_{DS}$  across the power DMOS. Please note that the voltage at the OUT pin is  $V_{BB} - V_{DS}$ . Please refer to following figures for details.

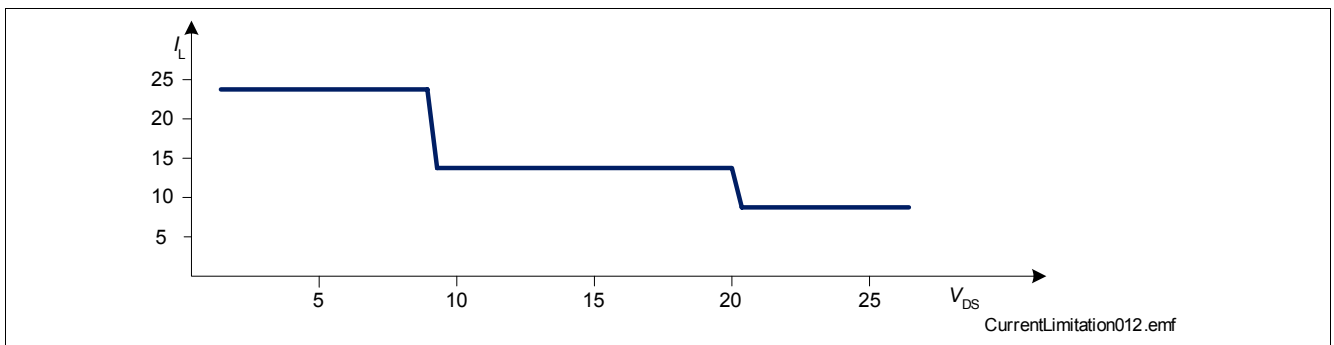

Figure 8 Current Limitation Channels 0, 1, 2 (minimum values)

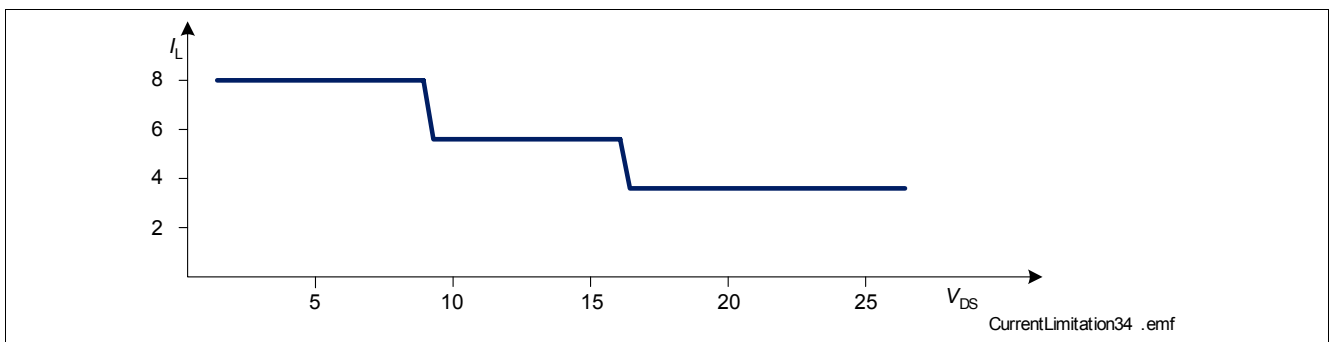

Figure 9 Current Limitation Channels 3, 4 (minimum values)

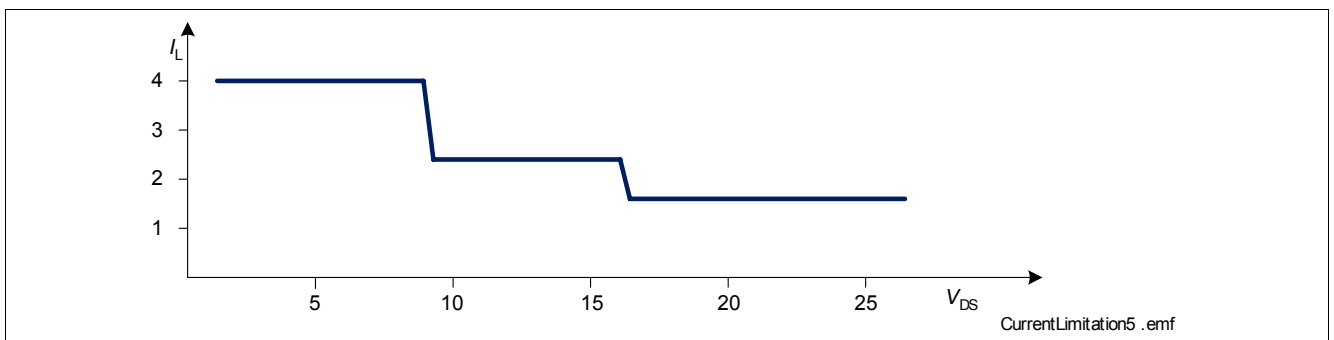
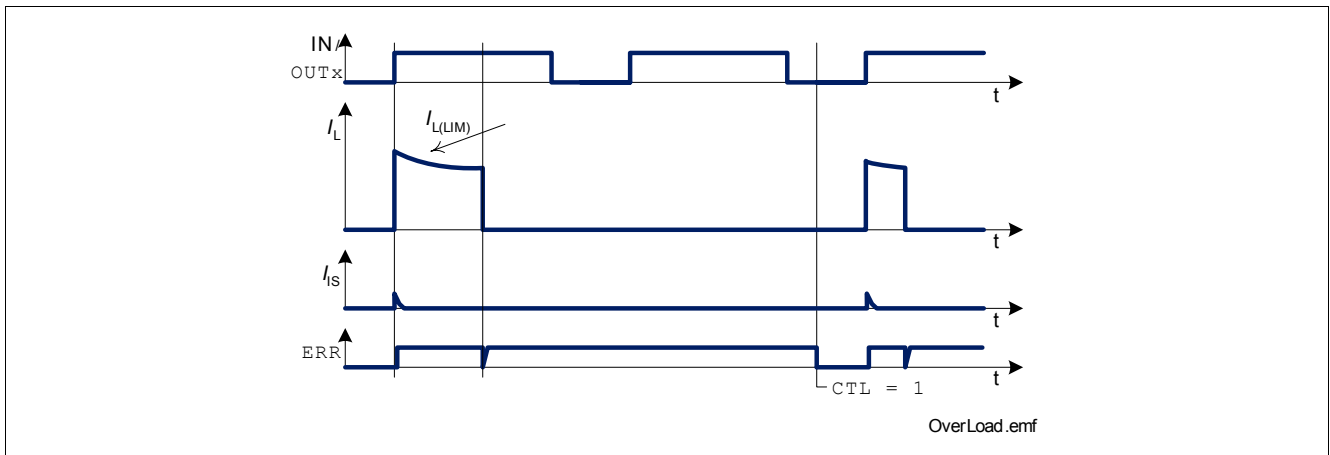

Figure 10 Current Limitation Channels 5 (minimum values)

Current limitation to the value  $I_{L(LIM)}$  is realized by increasing the resistance of the output channel, which leads to rapid temperature rise inside.

## 7.2 Over Temperature Protection

Each channel has its own temperature sensor. If the temperature at the channel exceeds the thermal shutdown temperature  $T_{j(SC)}$ , the channel will switch off and latch to prevent destruction (also in case of  $V_{DD} = 0V$ ). In order to reactivate the channel, the temperature at the output must drop by at least the thermal hysteresis  $\Delta T_j$  and the over temperature latch must be cleared by SPI command `HWCR.CTL = 1`. All over temperature latches are cleared by SPI command `HWCR.CTL = 1`.



**Figure 11 Shut Down by Over Temperature**

Additionally, channels 0, 1, 2, 3, 4 have their own dynamic temperature sensors. The dynamic temperature sensor improves short circuit robustness by limiting sudden increases in the junction temperature. The dynamic temperature sensor turns off the channel if its sudden temperature increase exceeds the dynamic temperature sensor threshold  $\Delta T_{j(SW)}$ . Please refer to the following figure for details.

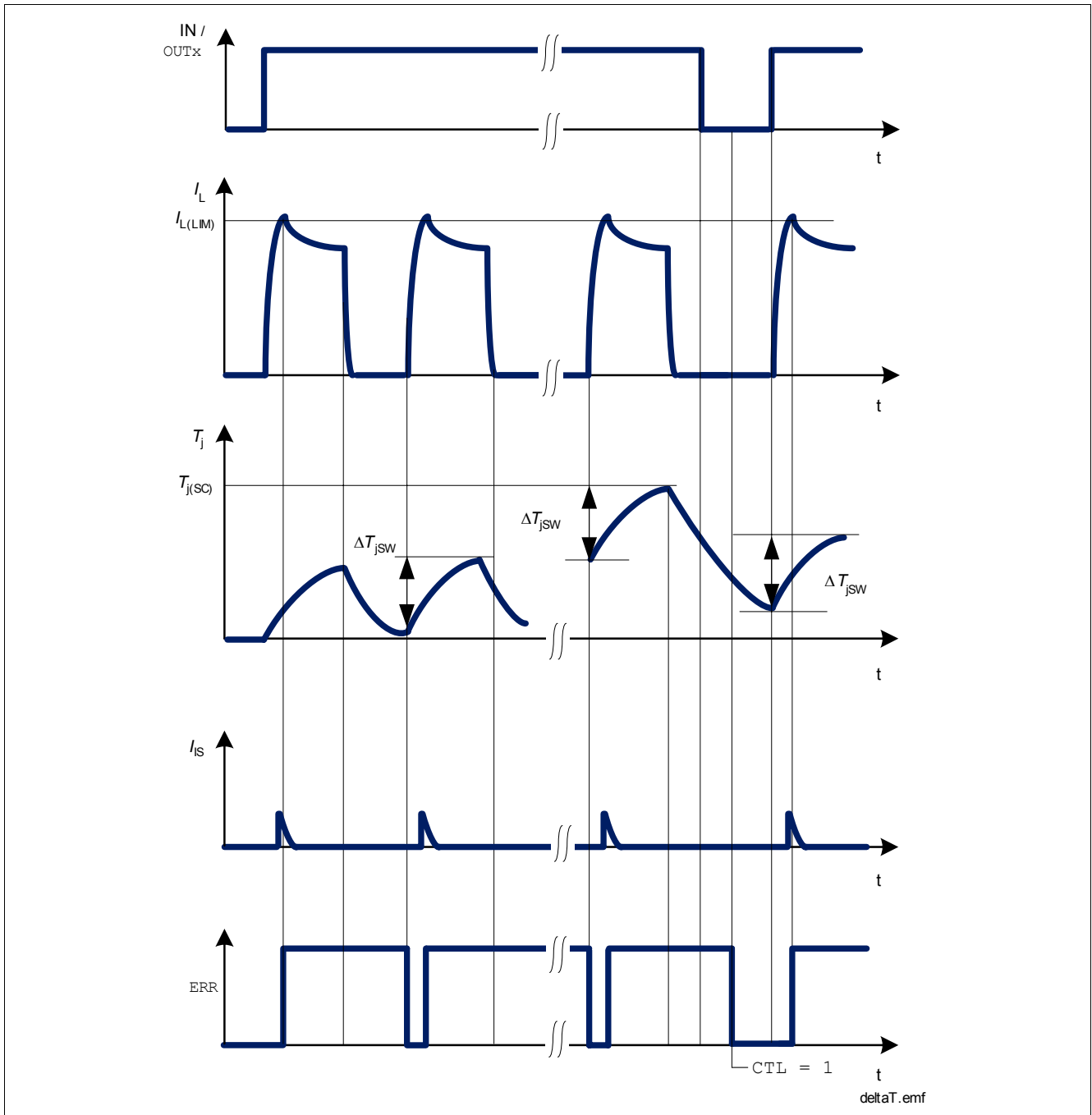

**Figure 12 Dynamic Temperature Sensor Operations**

The ERR-flag will be set during dynamic temperature sensor shut down. It can be reset by reading the ERR-flag. If the channel is still in dynamic temperature sensor shut down, the ERR-flag will be set again.

### 7.3 Reverse Polarity Protection

In reverse polarity mode, power dissipation is caused by the intrinsic body diode of each DMOS channel as well as each ESD diode of the logic pins. The reverse current through the channels has to be limited by the connected loads. The current through the ground pin, sense pin IS, the logic power supply pin  $V_{DD}$ , the SPI pins and the limp home input pin has to be limited as well (please refer to the maximum ratings listed on [Page 9](#)).

*Note: No protection mechanism like temperature protection or current limitation is active during reverse polarity.*

#### 7.4 Over Voltage Protection

In addition to the output clamp for inductive loads as described in [Section 6.3](#), there is a clamp mechanism available for over voltage protection. The current through the ground connection has to be limited during over voltage. Please note that in case of over voltage the pin GND might have a high voltage offset to the module ground.

#### 7.5 Loss of Ground

In case of complete loss of the device ground connections, but connected load ground, the SPOC - BTS5662E securely changes to or stays in off-state.

#### 7.6 Loss of $V_{BB}$

In case of loss of  $V_{BB}$  connection in on-state, all inductances of the loads have to be demagnetized through the ground connection or through an additional path from  $V_{BB}$  to ground. When a diode is used in the ground path for reverse polarity reason, the ground connection is not available for demagnetization. Then for example, a resistor can be placed in parallel to the diode or a suppressor diode can be used between  $V_{BB}$  and GND.

## 7.7 Electrical Characteristics

### Electrical Characteristics Protection Functions

Unless otherwise specified:  $V_{BB} = 9\text{ V to }16\text{ V}$ ,  $T_j = -40\text{ °C to }+150\text{ °C}$   
 typical values:  $V_{BB} = 13.5\text{ V}$ ,  $T_j = 25\text{ °C}$

Pos.	Parameter	Symbol	Limit Values			Unit	Test Conditions	
			min.	typ.	max.			
<b>Over Load Protection</b>								
7.7.1	Load current limitation	$I_{L(LIM)}$				A	$V_{DS} = 7\text{ V}$	
	channel 0, 1, 2		24	–	40			1)
	channel 3, 4		8	–	18			1)
	channel 5		4	–	7			–
<b>Over Temperature Protection</b>								
7.7.2	Thermal shut down temperature	$T_{j(SC)}$	150	170	190	°C	2)	
7.7.3	Thermal hysteresis	$\Delta T_j$	–	7	–	K	2)	
7.7.4	Dynamic temperature increase limitation while switching	$\Delta T_{jsw}$	–	60	–	K	2)	
<b>Over Voltage</b>								
7.7.5	Overvoltage protection	$V_{BB(AZ)}$	40	47	54	V	$I_{bb} = 4\text{ mA}$	

1) For  $T_j = 150\text{ °C}$ , not subject to production test. Device will shutdown due to the maximum junction temperature sensor.

2) Not subject to production test, specified by design.

## 7.8 Command Description

### HWCR

#### Hardware Configuration Register

W/R	RB	ADDR	3	2	1	0
write	1	1	0	0	RST	CTL

Field	Bits	Type	Description
CTL	0	rw	<b>Clear Thermal Latch</b> <b>0</b> Thermal latches are untouched <b>1</b> Command: Clear all thermal latches



For diagnosis feedback at different operation modes, please see [Table 1](#).

**Table 1 Operation Modes <sup>1)</sup>**

Operation Mode	Input Level OUT. OUTn	Output Level $V_{OUT}$	Current Sense $I_{IS}$	Error Flag ERRn <sup>2)</sup>	DCR. SBM
Normal Operation (OFF)	L / 0	GND	Z	0	1
Short Circuit to GND	(OFF-state)	GND	Z	0	1
Thermal shut down		Z	Z	0 <sup>3)</sup>	x
Short Circuit to $V_{BB}$		$V_{BB}$	Z	0	0
Open Load		Z	Z	0	x
Normal Operation (ON)		H / 1	$\sim V_{BB}$	$I_L / k_{ILIS}$	0
Current Limitation	(ON-state)	$< V_{BB}$	Z	1	x
Short Circuit to GND		$\sim$ GND	Z	1	1
Dynamic Temperature Sensor shut down		Z	Z	1	x
Thermal shut down		Z	Z	1 <sup>3)</sup>	x
Short Circuit to $V_{BB}$		$V_{BB}$	$< I_L / k_{ILIS}$	0	0
Open Load		$V_{BB}$	Z	0	0

1) L = low level, H = high level, Z = high impedance, potential depends on leakage currents and external circuit.  
x = undefined.

2) The error flags are latched until they are transmitted in the standard diagnosis word via SPI.

3) The over temperature flag is set latched (in OFF states also) and can be cleared by SPI command `HWCR.CTL`.

## 8.1 Diagnosis Word at SPI

The standard diagnosis at the SPI interface provides information about each channel. The error flags, an OR combination of the over temperature flags and the over load monitoring signals are provided in the SPI standard diagnosis bits `ERRn`.

The over load monitoring signals are latched in the error flags and cleared each time the standard diagnosis is transmitted via SPI. In detail, they are cleared between the second and third raising edge of the SCLK signal.

The over temperature flags, which cause an overheated channel to latch off, are latched directly at the gate control block. The latches are cleared by SPI command `HWCR.CTL`.

Please note: The over temperature information is latched twice. When transmitting a clear thermal latch command (`HWCR.CTL`), the error flag is cleared during command transmission of the next SPI frame and ready for latching after the third raising edge of the SCLK signal. As a result, the first standard diagnosis information after a `CTL` command will indicate a failure mode at the previously affected channels although the thermal latches have been cleared already. In case of continuous over load, the error flags are set again immediately because of the over load monitoring signal.

## 8.2 Load Current Sense Diagnosis

There is a current sense signal available at pin IS which provides a current proportional to the load current of one selected channel. The selection is done by a multiplexer which is configured via SPI.

### Current Sense Signal

The current sense signal (ratio  $k_{ILIS} = I_L / I_S$ ) is provided as long as no failure mode occurs. Usually a resistor  $R_{IS}$  is connected to the current sense pin. It is recommended to use resistors  $2.5 \text{ k}\Omega < R_{IS} < 7 \text{ k}\Omega$ . A typical value is  $3.3 \text{ k}\Omega$ .

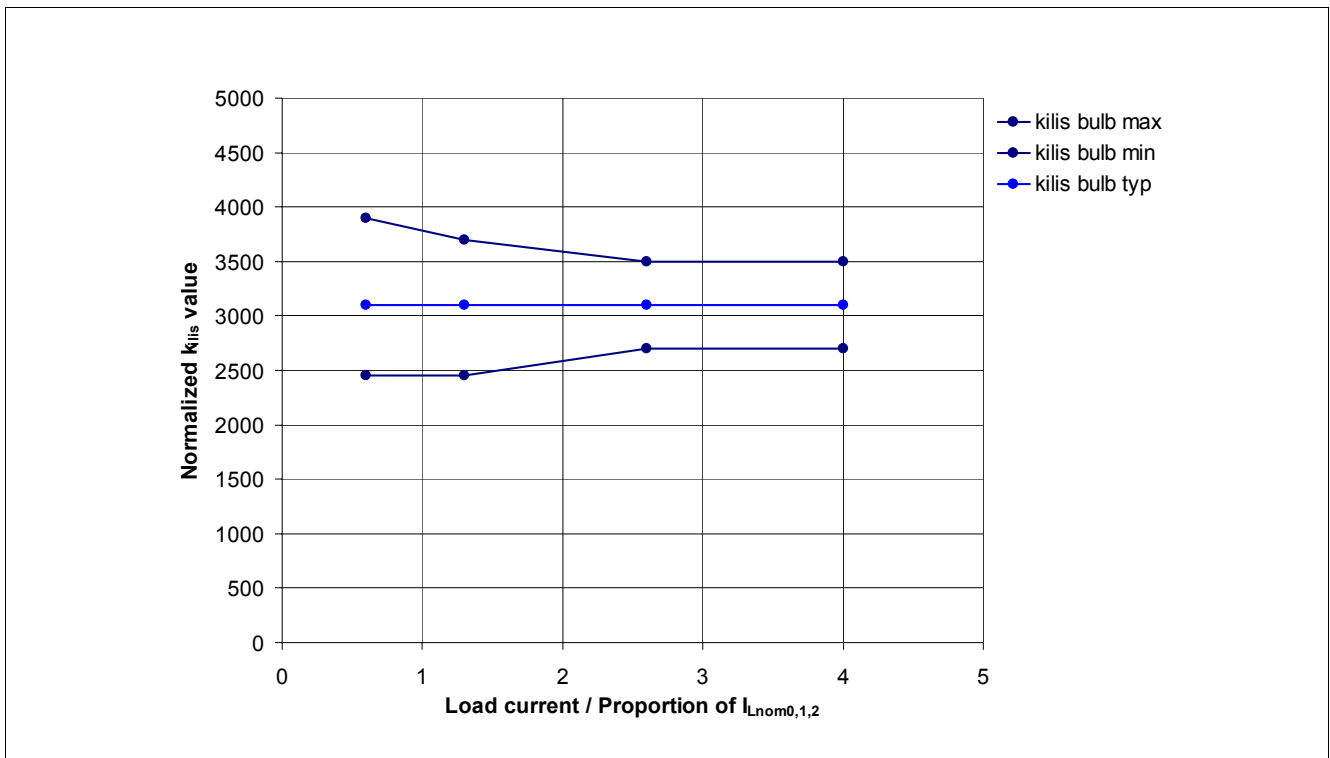

Figure 14 Current Sense Ratio  $k_{ILIS}$  Channel 0, 1, 2 <sup>1)</sup>

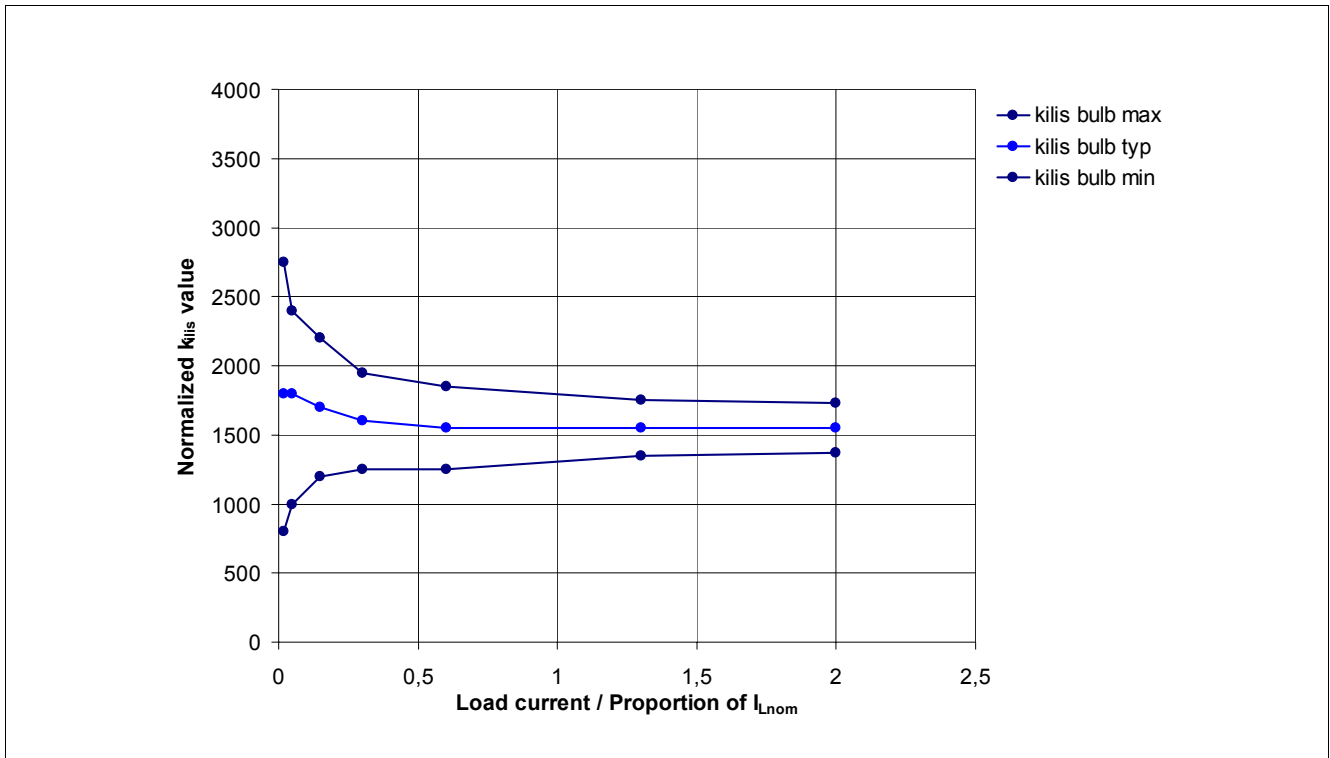

Figure 15 Current Sense Ratio  $k_{ILIS}$  Channel 3, 4<sup>1)</sup>

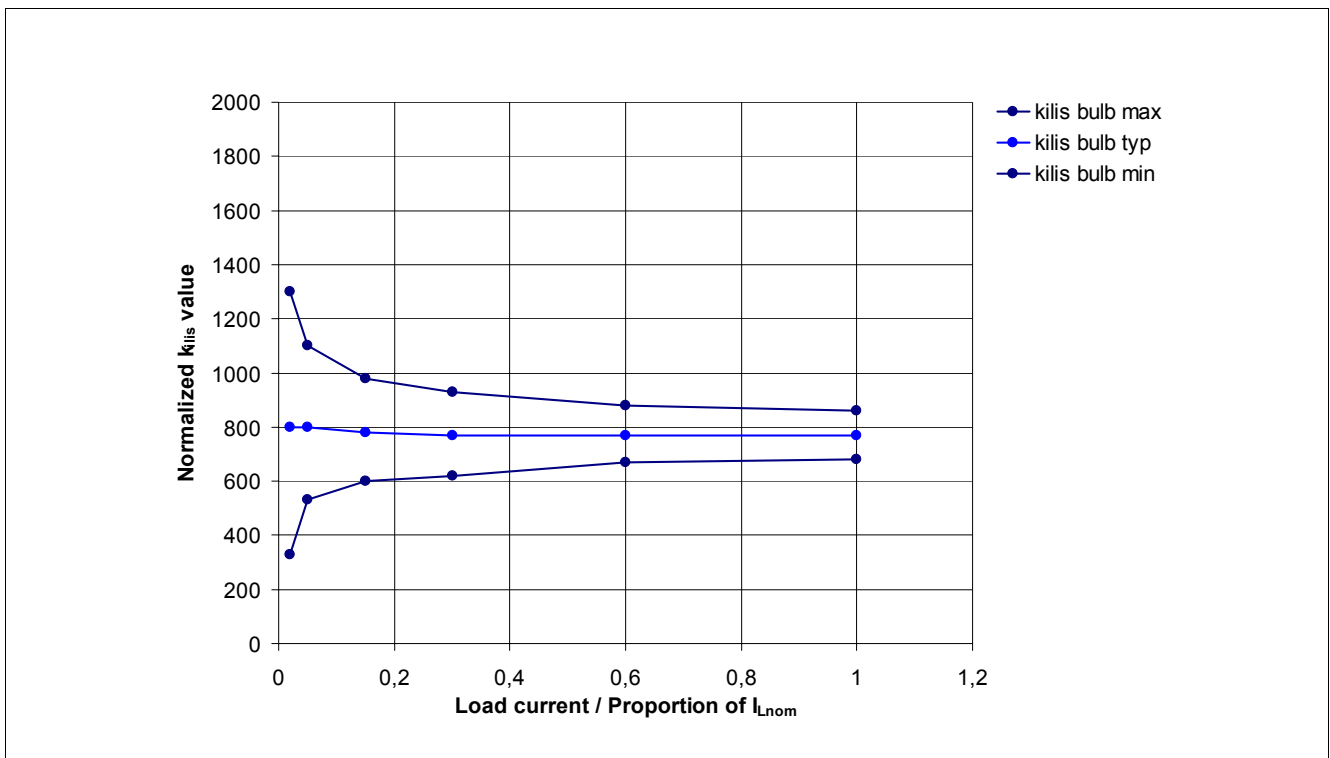
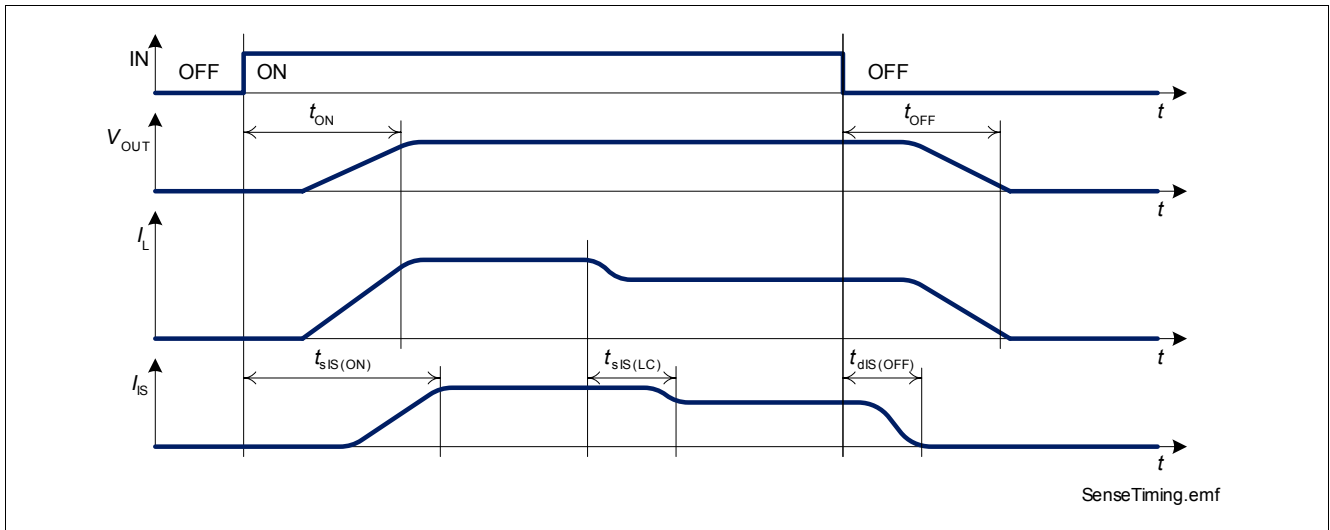

Figure 16 Current Sense Ratio  $k_{ILIS}$  Channel 5<sup>1)</sup>

1) The curves show the behavior based on characterization data. The marked points are guaranteed in this Data Sheet in [Section 8.4](#) (Position [8.4.1](#)).

In case of over current as well as over temperature, the current sense signal of the affected channel is switched off. To distinguish between over temperature and over load, the SPI diagnosis word can be used. Whereas the over load flag is cleared every time the diagnosis is transmitted, the over temperature flag is cleared by a dedicated SPI command (`HWCR.CTL`).

Details about timings between the current sense signal  $I_{IS}$  and the output voltage  $V_{OUT}$  and the load current  $I_L$  can be found in [Figure 17](#).



**Figure 17 Timing of Current Sense Signal**

### Current Sense Multiplexer

There is a current sense multiplexer implemented in the SPOC - BTS5662E that routes the sense current of the selected channel to the diagnosis pin IS. The channel is selected via SPI register `DCR.MUX`. The sense current also can be disabled by SPI register `DCR.MUX`. For details on timing of the current sense multiplexer, please refer to [Figure 18](#).

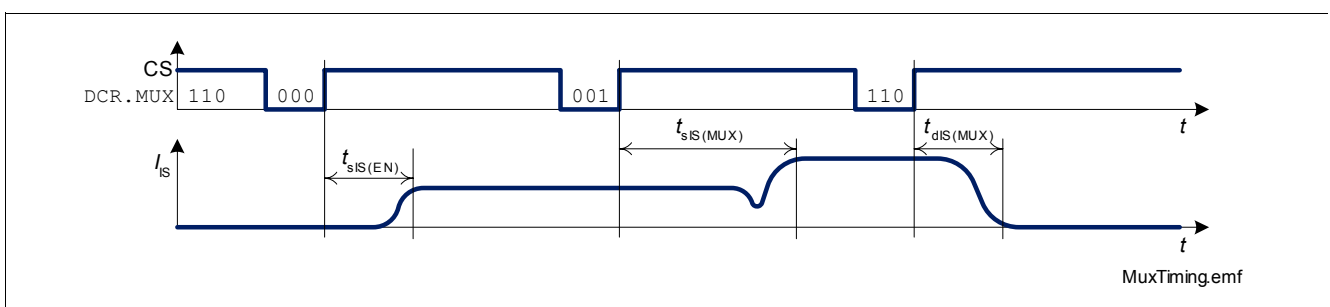

**Figure 18 Timing of Current Sense Multiplexer**

### 8.3 Switch Bypass Diagnosis

To detect short circuit to  $V_{BB}$ , there is a switch bypass monitor implemented. In case of short circuit between the output pin OUT and  $V_{BB}$  in ON-state, the current will flow through the power transistor as well as through the short circuit (bypass) with undefined ratio. As a result, the current sense signal will show lower values than expected by the load current. In OFF-state, the output voltage will stay close to  $V_{BB}$  potential which means a small  $V_{DS}$ .

The switch bypass monitor compares the voltage  $V_{DS}$  across the power transistor of that channel which is selected by the current sense multiplexer (`DCR.MUX`) with threshold  $V_{DS(SB)}$ . The result of comparison can be read in SPI register `DCR.SBM`.

### 8.4 Electrical Characteristics

Unless otherwise specified:  $V_{BB} = 9\text{ V to }16\text{ V}$ ,  $T_j = -40\text{ °C to }+150\text{ °C}$

typical values:  $V_{BB} = 13.5\text{ V}$ ,  $T_j = 25\text{ °C}$

Pos.	Parameter	Symbol	Limit Values			Unit	Test Conditions
			min.	typ.	max.		
<b>Load Current Sense</b>							
8.4.1	Current sense ratio channel 0, 1, 2:	$k_{ILIS}$					
	0.600 A		2450	3100	3900		—
	1.3 A		2450	3100	3700		—
	2.6 A		2700	3100	3500		—
	4.0 A		2700	3100	3500		—
	channel 3, 4:						
	0.020 A		800	1800	2750		—
	0.050 A		1000	1800	2400		—
	0.150 A		1200	1700	2200		—
	0.300 A		1250	1600	1950		—
	0.600 A		1250	1550	1850		—
	1.3 A		1350	1550	1750		—
	2.0 A		1370	1550	1730		—
	channel 5:						
	0.020 A	330	800	1300		—	
	0.050 A	530	800	1100		—	
	0.150 A	600	780	980		—	
	0.300 A	620	770	930		—	
	0.600 A	670	770	880		—	
	1.0 A	680	770	860		—	
8.4.2	Current sense voltage limitation	$V_{IS(LIM)}$	$0.9V_{DD}$	$V_{DD}$	$1.1V_{DD}$	V	$I_{IS} = 1\text{ mA}$

Unless otherwise specified:  $V_{BB} = 9\text{ V to }16\text{ V}$ ,  $T_j = -40\text{ °C to }+150\text{ °C}$   
 typical values:  $V_{BB} = 13.5\text{ V}$ ,  $T_j = 25\text{ °C}$

Pos.	Parameter	Symbol	Limit Values			Unit	Test Conditions
			min.	typ.	max.		
8.4.3	Current sense leakage / offset current	$I_{IS(en)}$	–	–	1	$\mu\text{A}$	$I_L = 0$ DCR.MUX = 000 <sub>B</sub>
8.4.4	Current sense leakage, while diagnosis disabled	$I_{IS(dis)}$	–	–	1	$\mu\text{A}$	DCR.MUX = 110 <sub>B</sub>
8.4.5	Current sense settling time after channel activation	$t_{sIS(ON)}$				$\mu\text{s}$	$V_{BB} = 13.5\text{ V}$ $R_{IS} = 3.3\text{ k}\Omega$ $R_L = 6.8\ \Omega$
	channel 0, 1, 2		–	–	300		$R_L = 18\ \Omega$
	channel 3, 4		–	–	180		$R_L = 33\ \Omega$
	channel 5		–	–	180		
8.4.6	Current sense desettling time after channel deactivation	$t_{dis(OFF)}$	–	–	25	$\mu\text{s}$	$V_{BB} = 13.5\text{ V}^{1)}$ $R_{IS} = 3.3\text{ k}\Omega$
8.4.7	Current sense settling time after change of load current	$t_{sIS(LC)}$				$\mu\text{s}$	$V_{BB} = 13.5\text{ V}^{1)}$ $R_{IS} = 3.3\text{ k}\Omega$
	channel 0, 1, 2		–	–	30		$I_L = 2.6\text{ A to }1.3\text{ A}$
	channel 3, 4		–	–	30		$I_L = 1.3\text{ A to }0.6\text{ A}$
	channel 5		–	–	30		$I_L = 0.6\text{ A to }0.3\text{ A}$
8.4.8	Current sense settling time after current sense activation	$t_{sIS(EN)}$	–	–	25	$\mu\text{s}$	$R_{IS} = 3.3\text{ k}\Omega$ DCR.MUX: 110 <sub>B</sub> -> 000 <sub>B</sub>
8.4.9	Current sense settling time after multiplexer channel change	$t_{sIS(MUX)}$	–	–	30	$\mu\text{s}$	$R_{IS} = 3.3\text{ k}\Omega$ DCR.MUX: 000 <sub>B</sub> -> 001 <sub>B</sub>
8.4.10	Current sense deactivation time	$t_{dis(MUX)}$	–	–	25	$\mu\text{s}$	$R_{IS} = 3.3\text{ k}\Omega$ DCR.MUX: <sup>1)</sup> 001 <sub>B</sub> -> 110 <sub>B</sub>

**Switch Bypass Monitor**

8.4.11	Switch bypass monitor threshold	$V_{DS(SB)}$	0.7	–	2.5	V	–
--------	---------------------------------	--------------	-----	---	-----	---	---

1) Not subject to production test, specified by design.

## 8.5 Command Description

### DCR

#### Diagnosis Control Register

W/R	RB	ADDR			3	2	1	0
read	1	1	1	1	SBM		MUX	
write	1	1	1	1	0		MUX	

Input Level OUT. OUTn	Field	Bits	Type	Description
L / 0 (OFF-state)	MUX	2:0	rw	<b>Set Current Sense Multiplexer Configuration</b> 000 IS pin is high impedance 001 IS pin is high impedance 010 IS pin is high impedance 011 IS pin is high impedance 100 IS pin is high impedance 101 IS pin is high impedance 110 IS pin is high impedance 111 Stand-by mode (IS pin is high impedance)
	SBM	3	r	<b>Switch Bypass Monitor<sup>1)</sup></b> 0 $V_{DS} < V_{DS(SB)}$ 1 $V_{DS} > V_{DS(SB)}$
H / 1 (ON-state)	MUX	2:0	rw	<b>Set Current Sense Multiplexer Configuration</b> 000 current sense of channel 0 is routed to IS pin 001 current sense of channel 1 is routed to IS pin 010 current sense of channel 2 is routed to IS pin 011 current sense of channel 3 is routed to IS pin 100 current sense of channel 4 is routed to IS pin 101 current sense of channel 5 is routed to IS pin 110 IS pin is high impedance 111 Stand-by mode (IS pin is high impedance)
	SBM	3	r	<b>Switch Bypass Monitor<sup>1)</sup></b> 0 $V_{DS} < V_{DS(SB)}$ 1 $V_{DS} > V_{DS(SB)}$

1) Invalid in stand-by mode

**Standard Diagnosis**

CS	7	6	5	4	3	2	1	0
TER	0	LHI	ERR5	ERR4	ERR3	ERR2	ERR1	ERR0

Field	Bits	Type	Description
ERRn n = 5 to 0	n	r	<b>Error flag Channel n</b> 0 normal operation 1 failure mode occurred

## 9 Serial Peripheral Interface (SPI)

The serial peripheral interface (SPI) is a full duplex synchronous serial slave interface, which uses four lines:  $\overline{CS}$ , SI, SCLK and SO. Data is transferred by the lines SI and SO at the rate given by SCLK. The falling edge of  $\overline{CS}$  indicates the beginning of an access. Data is sampled in on line SI at the falling edge of SCLK and shifted out on line SO at the rising edge of SCLK. Each access must be terminated by a rising edge of  $\overline{CS}$ . A modulo 8 counter ensures that data is taken only, when a multiple of 8 bit has been transferred. The interface provides daisy chain capability.

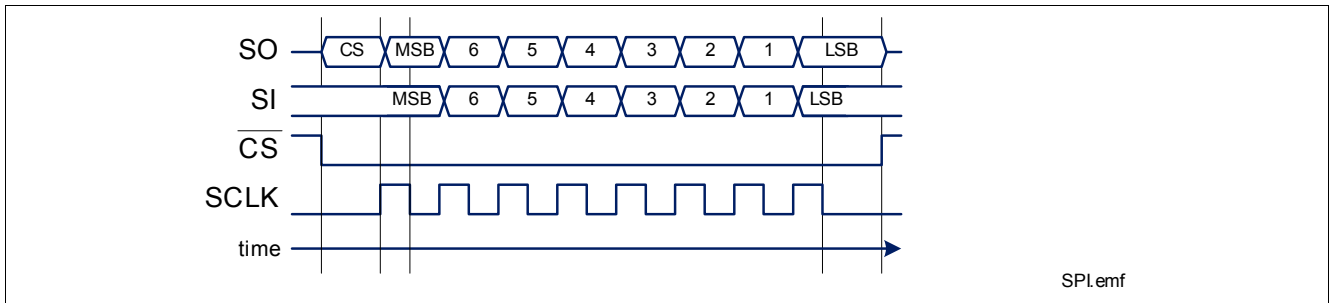

Figure 19 Serial Peripheral Interface

### 9.1 SPI Signal Description

#### $\overline{CS}$ - Chip Select:

The system micro controller selects the SPOC - BTS5662E by means of the  $\overline{CS}$  pin. Whenever the pin is in low state, data transfer can take place. When  $\overline{CS}$  is in high state, any signals at the SCLK and SI pins are ignored and SO is forced into a high impedance state.

#### $\overline{CS}$ High to Low transition:

- The requested information is transferred into the shift register.
- SO changes from high impedance state to high or low state depending on the logic OR combination between the transmission error flag ( $\overline{TER}$ ) and the signal level at pin SI. As a result, even in daisy chain configuration, a high signal indicates a faulty transmission. This information stays available to the first rising edge of SCLK.

#### $\overline{CS}$ Low to High transition:

- Command decoding is only done, when after the falling edge of  $\overline{CS}$  exactly a multiple (1, 2, 3, ...) of eight SCLK signals have been detected. In case of faulty transmission, the transmission error flag ( $\overline{TER}$ ) is set and the command is ignored.
- Data from shift register is transferred into the addressed register.

#### SCLK - Serial Clock:

This input pin clocks the internal shift register. The serial input (SI) transfers data into the shift register on the falling edge of SCLK while the serial output (SO) shifts diagnostic information out on the rising edge of the serial clock. It is essential that the SCLK pin is in low state whenever chip select  $\overline{CS}$  makes any transition.

#### SI - Serial Input:

Serial input data bits are shift-in at this pin, the most significant bit first. SI information is read on the falling edge of SCLK. The input data consists of two parts, control bits followed by data bits. Please refer to [Section 9.5](#) for further information.

**SO Serial Output:**

Data is shifted out serially at this pin, the most significant bit first. SO is in high impedance state until the  $\overline{CS}$  pin goes to low state. New data will appear at the SO pin following the rising edge of SCLK. Please refer to [Section 9.5](#) for further information.

**9.2 Daisy Chain Capability**

The SPI of SPOC - BTS5662E provides daisy chain capability. In this configuration several devices are activated by the same  $\overline{CS}$  signal MCS. The SI line of one device is connected with the SO line of another device (see [Figure 20](#)), in order to build a chain. The ends of the chain are connected with the output and input of the master device, MO and MI respectively. The master device provides the master clock MCLK which is connected to the SCLK line of each device in the chain.

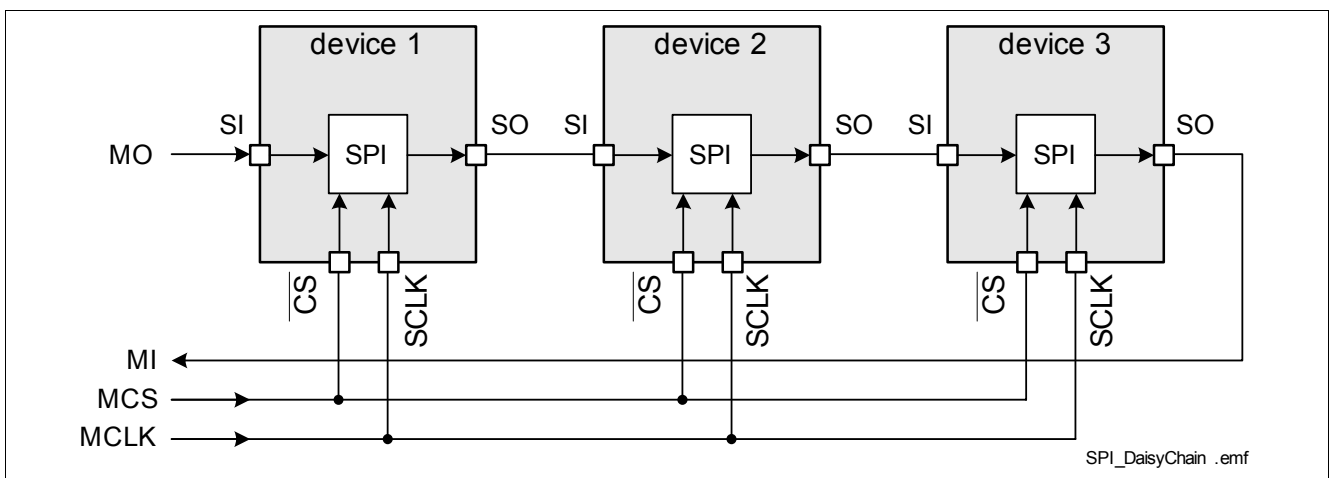

**Figure 20 Daisy Chain Configuration**

In the SPI block of each device, there is one shift register where one bit from SI line is shifted in each SCLK. The bit shifted out occurs at the SO pin. After eight SCLK cycles, the data transfer for one device has been finished. In single chip configuration, the  $\overline{CS}$  line must turn high to make the device accept the transferred data. In daisy chain configuration, the data shifted out at device 1 has been shifted in to device 2. When using three devices in daisy chain, three times eight bits have to be shifted through the devices. After that, the MCS line must turn high (see [Figure 21](#)).

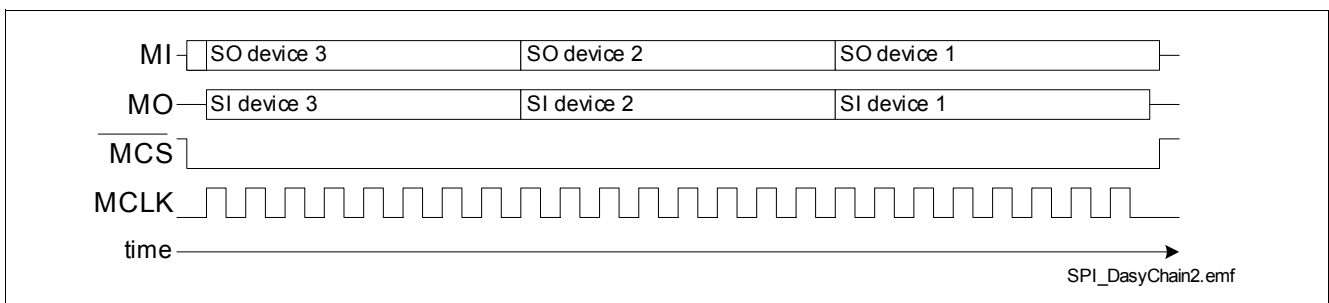

**Figure 21 Data Transfer in Daisy Chain Configuration**

### 9.3 Timing Diagrams

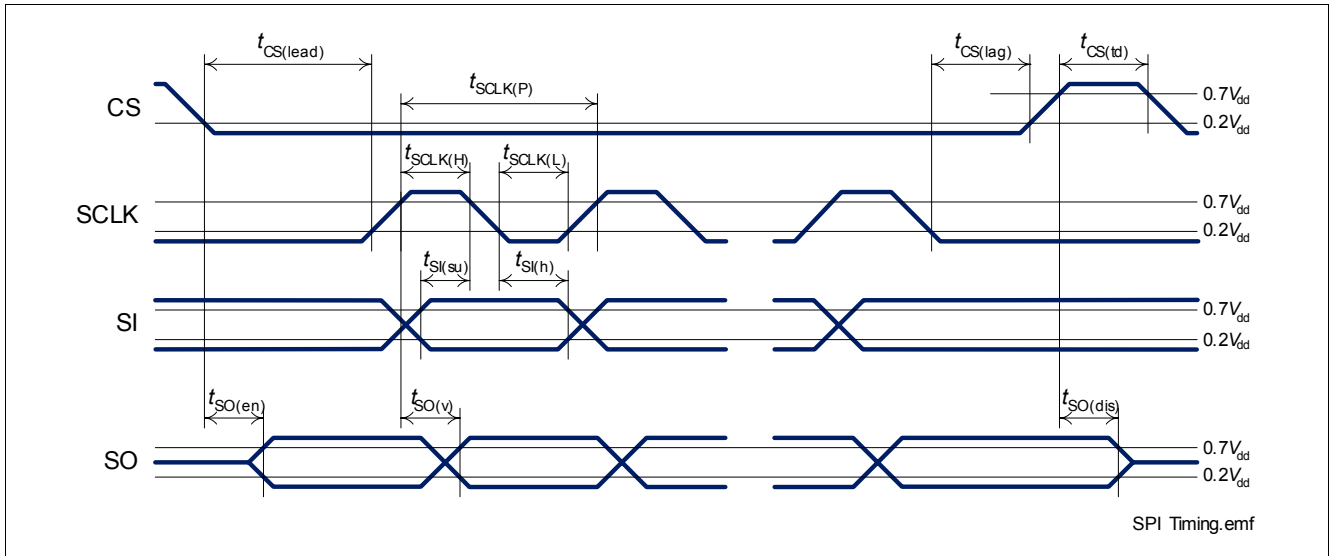

Figure 22 Timing Diagram SPI Access

### 9.4 Electrical Characteristics

Unless otherwise specified:  $V_{BB} = 9\text{ V to }16\text{ V}$ ,  $T_j = -40\text{ }^\circ\text{C to }+150\text{ }^\circ\text{C}$ ,  $V_{DD} = 3.8\text{ V to }5.5\text{ V}$   
 typical values:  $V_{BB} = 13.5\text{ V}$ ,  $T_j = 25\text{ }^\circ\text{C}$ ,  $V_{DD} = 4.3\text{ V}$

Pos.	Parameter	Symbol	Limit Values			Unit	Test Conditions
			min.	typ.	max.		
<b>Input Characteristics (CS, SCLK, SI)</b>							
9.4.1	L level of pin	$\overline{CS}$ $V_{CS(L)}$	-0.3	–	1.0	V	$V_{DD} = 4.3\text{ V}$
		SCLK $V_{SCLK(L)}$	-0.3	–	1.0		–
		SI $V_{SI(L)}$	-0.3	–	1.0		–
9.4.2	H level of pin	$\overline{CS}$ $V_{CS(H)}$	2.6	–	5.5	V	$V_{DD} = 4.3\text{ V}$
		SCLK $V_{SCLK(H)}$	2.6	–	5.5		–
		SI $V_{SI(H)}$	2.6	–	5.5		–
9.4.3	L-input pull-up current at $\overline{CS}$ pin	$-I_{CS(L)}$	10	30	85	$\mu\text{A}$	$V_{DD} = 4.3\text{ V}$ $V_{CS} = 0\text{ V}$
9.4.4	H-input pull-up current at $\overline{CS}$ pin	$-I_{CS(H)}$	3	–	85	$\mu\text{A}$	$V_{DD} = 4.3\text{ V}$ $V_{CS} = 2.6\text{ V}$
9.4.5	L-input pull-down current at pin	SCLK $I_{SCLK(L)}$	3	–	75	$\mu\text{A}$	$V_{DD} = 4.3\text{ V}$ $V_{SCLK} = 0.4\text{ V}$
		SI $I_{SI(L)}$	3	–	75		$V_{SI} = 0.4\text{ V}$
9.4.6	H-input pull-down current at pin	SCLK $I_{SCLK(H)}$	10	30	75	$\mu\text{A}$	$V_{DD} = 4.3\text{ V}$ $V_{SCLK} = 4.3\text{ V}$
		SI $I_{SI(H)}$	10	30	75		$V_{SI} = 4.3\text{ V}$
<b>Output Characteristics (SO)</b>							
9.4.7	L level output voltage	$V_{SO(L)}$	0	–	0.5	V	$I_{SO} = -0.5\text{ mA}$

**Serial Peripheral Interface (SPI)**

Unless otherwise specified:  $V_{BB} = 9\text{ V to }16\text{ V}$ ,  $T_j = -40\text{ °C to }+150\text{ °C}$ ,  $V_{DD} = 3.8\text{ V to }5.5\text{ V}$   
 typical values:  $V_{BB} = 13.5\text{ V}$ ,  $T_j = 25\text{ °C}$ ,  $V_{DD} = 4.3\text{ V}$

Pos.	Parameter	Symbol	Limit Values			Unit	Test Conditions
			min.	typ.	max.		
9.4.8	H level output voltage	$V_{SO(H)}$	$V_{DD} - 0.5\text{ V}$	–	$V_{DD}$	V	$I_{SO} = 0.5\text{ mA}$ $V_{DD} = 4.3\text{ V}$
9.4.9	Output tristate leakage current	$I_{SO(OFF)}$	-10	–	10	μA	$V_{CS} = V_{DD}$

**Timings**

9.4.10	Serial clock frequency	$f_{SCLK}$	0	–	2	MHz	–
9.4.11	Serial clock period	$t_{SCLK(P)}$	500	–	–	ns	–
9.4.12	Serial clock high time	$t_{SCLK(H)}$	250	–	–	ns	–
9.4.13	Serial clock low time	$t_{SCLK(L)}$	250	–	–	ns	–
9.4.14	Enable lead time (falling $\overline{CS}$ to rising SCLK)	$t_{CS(lead)}$	1	–	–	μs	–
9.4.15	Enable lag time (falling SCLK to rising $\overline{CS}$ )	$t_{CS(lag)}$	1	–	–	μs	–
9.4.16	Transfer delay time (rising $\overline{CS}$ to falling $\overline{CS}$ )	$t_{CS(td)}$	1	–	–	μs	–
9.4.17	Data setup time (required time SI to falling SCLK)	$t_{SI(su)}$	100	–	–	ns	–
9.4.18	Data hold time (falling SCLK to SI)	$t_{SI(h)}$	100	–	–	ns	–
9.4.19	Output enable time (falling $\overline{CS}$ to SO valid)	$t_{SO(en)}$	–	–	1	μs	$C_L = 20\text{ pF}^{1)}$
9.4.20	Output disable time (rising $\overline{CS}$ to SO tri-state)	$t_{SO(dis)}$	–	–	1	μs	$C_L = 20\text{ pF}^{1)}$
9.4.21	Output data valid time with capacitive load	$t_{SO(v)}$	–	–	250	ns	$C_L = 20\text{ pF}^{1)}$

1) Not subject to production test, specified by design.

### 9.5 SPI Protocol

	CS <sup>1)</sup>	7	6	5	4	3	2	1	0	
	Write OUT Register									
SI		1	0	OUT5	OUT4	OUT3	OUT2	OUT1	OUT0	
	Read OUT Register									
SI		0	0	x	x	x	x	x	0	
	Write Configuration Register									
SI		1	1	ADDR			DATA			
	Read Configuration Register									
SI		0	1	ADDR			x	x	x	0
	Read Standard Diagnosis									
SI		0	x	x	x	x	x	x	1	
	Standard Diagnosis									
SO	TER	0	LHI	ERR5	ERR4	ERR3	ERR2	ERR1	ERR0	
	Second Frame of Read Command									
SO	TER	1	0	OUT5	OUT4	OUT3	OUT2	OUT1	OUT0	
SO	TER	1	1	ADDR			DATA			

1) The SO pin shows this information between CS hi -> lo and first SCLK lo -> hi transition.

*Note: Reading a register needs two SPI frames. In the first frame the RD command is sent. In the second frame the output at SPI signal SO will contain the requested information. A new command can be executed in the second frame.*

Field	Bits	Type	Description
RB	6	rw	<b>Register Bank</b> 0 Read / write to the OUTx channel 1 Read / write to the other register
TER	CS	r	<b>Transmission Error</b> 0 Previous transmission was successful (modulo 8 clocks received) 1 Previous transmission failed or first transmission after reset
OUTx x = 5 to 0	x	rw	<b>Output Control Register of Channel x</b> 0 OFF 1 ON
ADDR	5:4	rw	<b>Address</b> Pointer to register for read and write command
DATA	3:0	rw	<b>Data</b> Data written to or read from register selected by address ADDR
LHI	6	r	<b>Limp Home Enable</b> 0 L-input signal at pin LHI 1 H-input signal at pin LHI
ERRx x = 5 to 0	x	r	<b>Diagnosis of Channel x</b> 0 No failure 1 Over temperature, over load or short circuit

## 9.6 Register Overview

Name	W/R	RB	5	4	3	2	1	0	default <sup>1)</sup>
OUT	W/R	0	OUT5	OUT4	OUT3	OUT2	OUT1	OUT0	00 <sub>H</sub>

Name	W/R	RB	ADDR		3	2	1	0	default <sup>1)</sup>
PCR	W/R	1	0	1	PWM	X	X	X	00 <sub>H</sub>
HWCR	R	1	1	0	0	X	STB	CTL	02 <sub>H</sub>
	W	1	1	0	0	0	RST	CTL	-
DCR	R	1	1	1	SBM		MUX		07 <sub>H</sub>
	W	1	1	1	0		MUX		-

1) The default values are set after reset.

# 10 Application Description

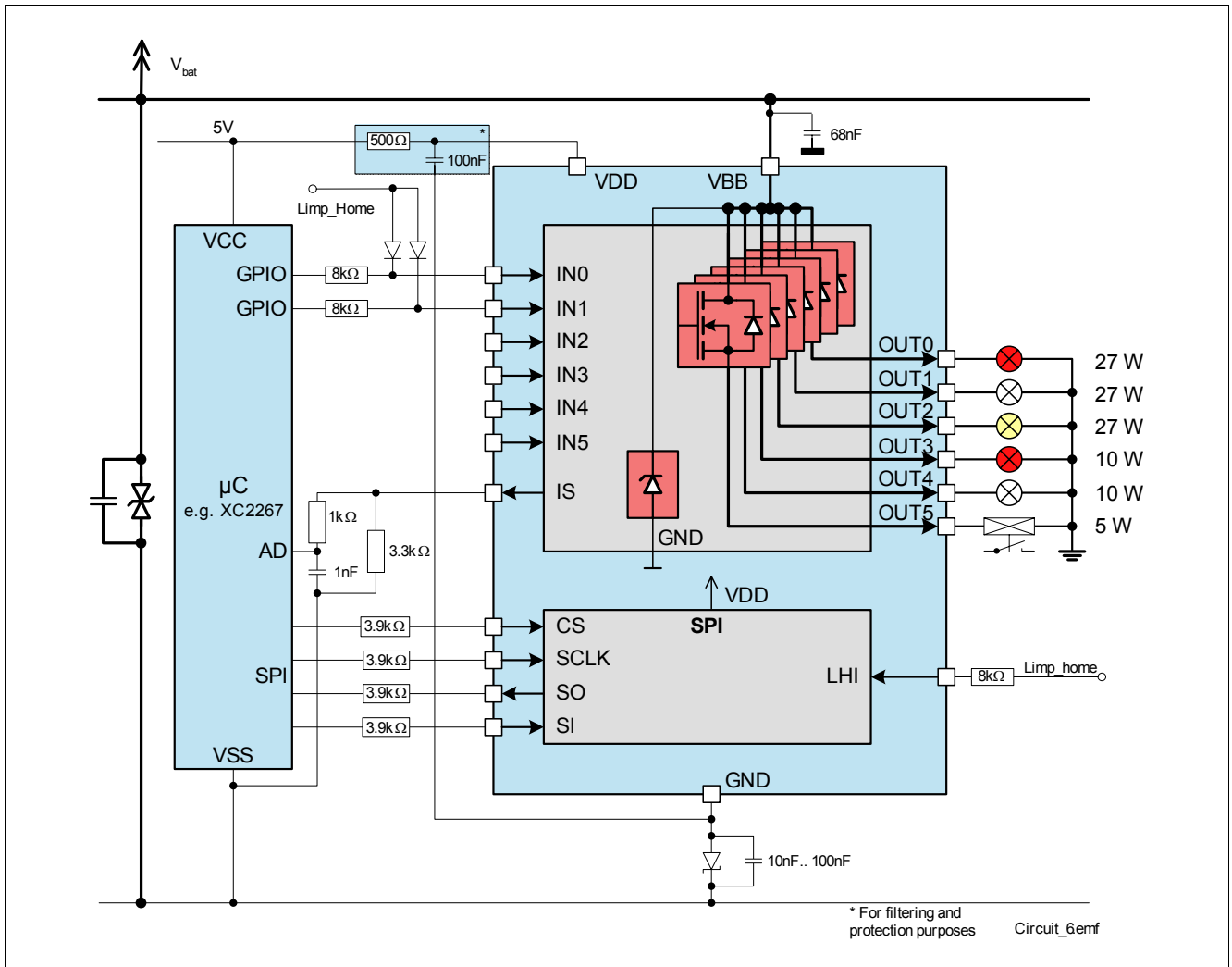

Figure 23 Application Circuit Example

## 11 Package Outlines SPOC - BTS5662E

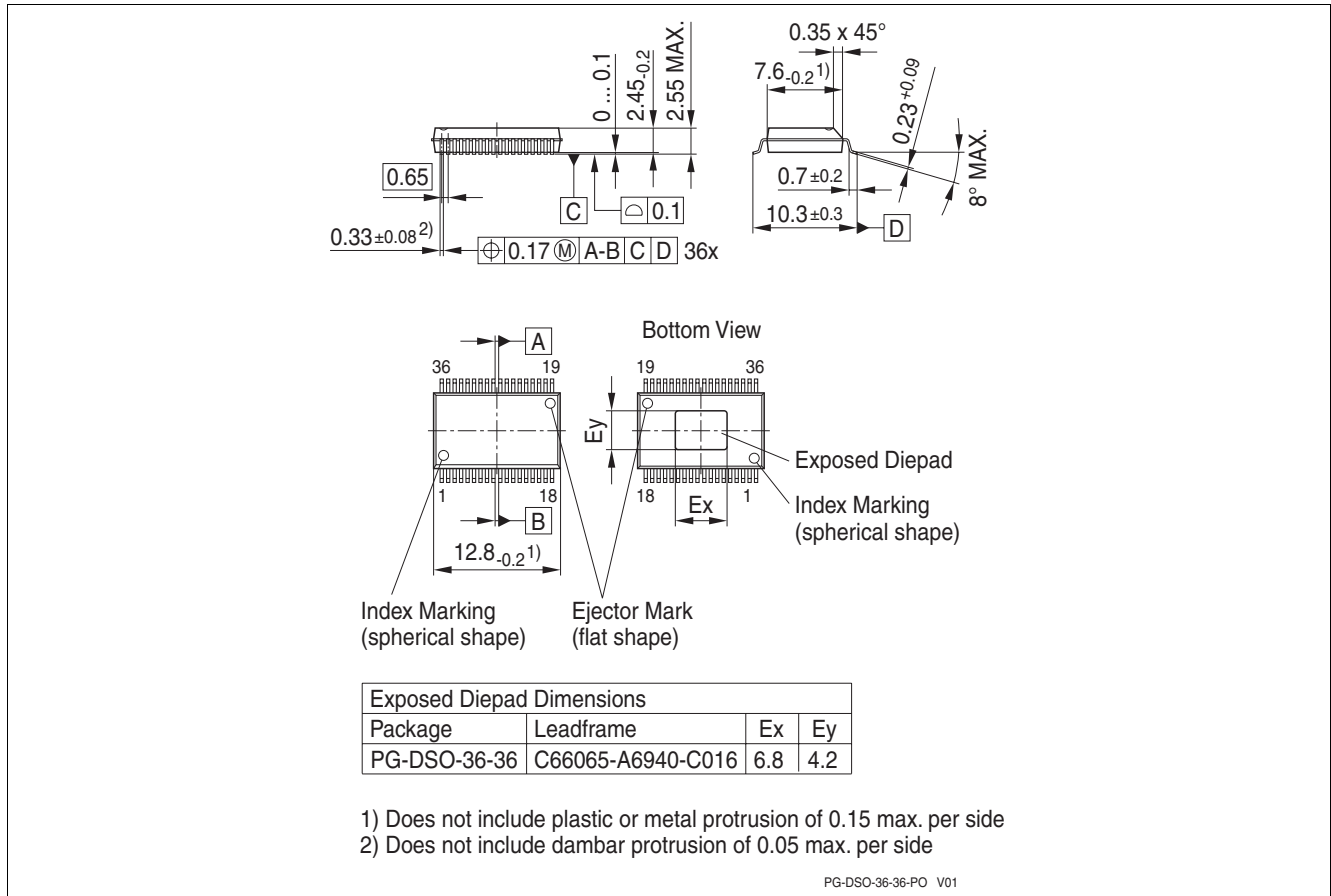

Figure 24 PG-DSO-36-36 (Plastic Dual Small Outline Package)

### Green Product (RoHS compliant)

To meet the world-wide customer requirements for environmentally friendly products and to be compliant with government regulations the device is available as a green product. Green products are RoHS-Compliant (i.e Pb-free finish on leads and suitable for Pb-free soldering according to IPC/JEDEC J-STD-020).

For further information on alternative packages, please visit our website:  
<http://www.infineon.com/packages>.

## 12 Revision History

Revision	Date	Changes
1.0	08-01-22	Initial revision

**Edition 2008-01-22**

**Published by  
Infineon Technologies AG  
81726 Munich, Germany**

**© 2008 Infineon Technologies AG  
All Rights Reserved.**

### **Legal Disclaimer**

The information given in this document shall in no event be regarded as a guarantee of conditions or characteristics. With respect to any examples or hints given herein, any typical values stated herein and/or any information regarding the application of the device, Infineon Technologies hereby disclaims any and all warranties and liabilities of any kind, including without limitation, warranties of non-infringement of intellectual property rights of any third party.

### **Information**

For further information on technology, delivery terms and conditions and prices, please contact the nearest Infineon Technologies Office ([www.infineon.com](http://www.infineon.com)).



### **Warnings**

Due to technical requirements, components may contain dangerous substances. For information on the types in question, please contact the nearest Infineon Technologies Office.

Infineon Technologies components may be used in life-support devices or systems only with the express written approval of Infineon Technologies, if a failure of such components can reasonably be expected to cause the failure of that life-support device or system or to affect the safety or effectiveness of that device or system. Life support devices or systems are intended to be implanted in the human body or to support and/or maintain and sustain and/or protect human life. If they fail, it is reasonable to assume that the health of the user or other persons may be endangered.

## Looking for pricing, stock, or lifecycle information?

Click below to explore more details on WIN SOURCE:

-  [View BTS5662E on WIN SOURCE](#)
-  [Infineon Technologies](#) Information

## Optimize Your Supply Chain with WIN SOURCE Solutions

-  Global Sourcing Solution
-  Obsolete Management
-  Cost Control Management
-  Shortage Management
-  Alternative Solution
-  Excess Inventory Management