



**THE DATASHEET OF
BTS5440GXUMA1**



Smart High-Side Power Switch

Four Channels: 4 x 25mΩ

IntelliSense

Product Summary

Operating voltage	$V_{bb(on)}$	4,5...28 (Loaddump: 40 V)		V
	Active channels	one	four parallel	
On-state resistance	R_{ON}	25	6.5	mΩ
Nominal load current	$I_{L(nom)}$	6.2	13.9	A
Current limitation	Low	$I_{L(SCr)}$		10
	High			40

Package

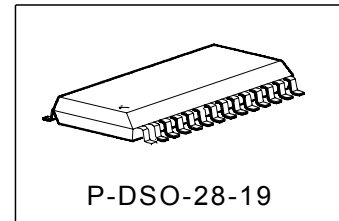

General Description

- N channel vertical power MOSFET with charge pump, ground referenced CMOS compatible input and diagnostic feedback, monolithically integrated in Smart SIPMOS® technology.
- Providing embedded protective functions.
- Extern adjustable current limitation.

Application

- All types of resistive, inductive and capacitive loads
- μC compatible high-side power switch with diagnostic feedback for 12 V grounded loads
- Due to the adjustable current limitation best suitable for loads with high inrush currents, so as lamps
- Replaces electromechanical relays, fuses and discrete circuits

Basic Functions

- Very low standby current
- CMOS compatible input
- Improved electromagnetic compatibility (EMC)
- Stable behaviour at low battery voltage

Protection Functions

- Reverse battery protection with external resistor
- Short circuit protection
- Overload protection
- Current limitation
- Thermal Shutdown
- Overvoltage protection with external resistor
- Loss of GND and loss of V_{bb} protection
- Electrostatic discharge Protection (ESD)

Diagnostic Functions: IntelliSense

- Proportional load current sense (with defined fault signal during thermal shutdown and overload)
- Additional open load detection in OFF - state
- Suppressed thermal toggling of fault signal

Block Diagram

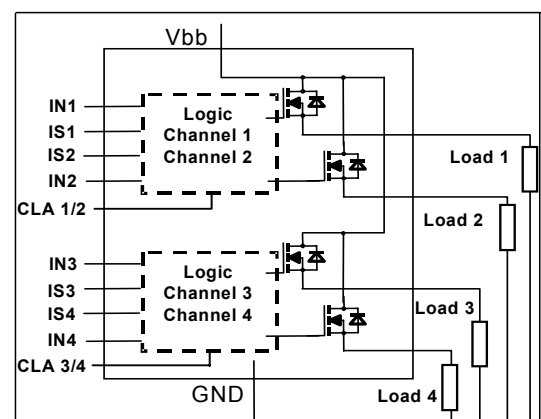

Functional diagram

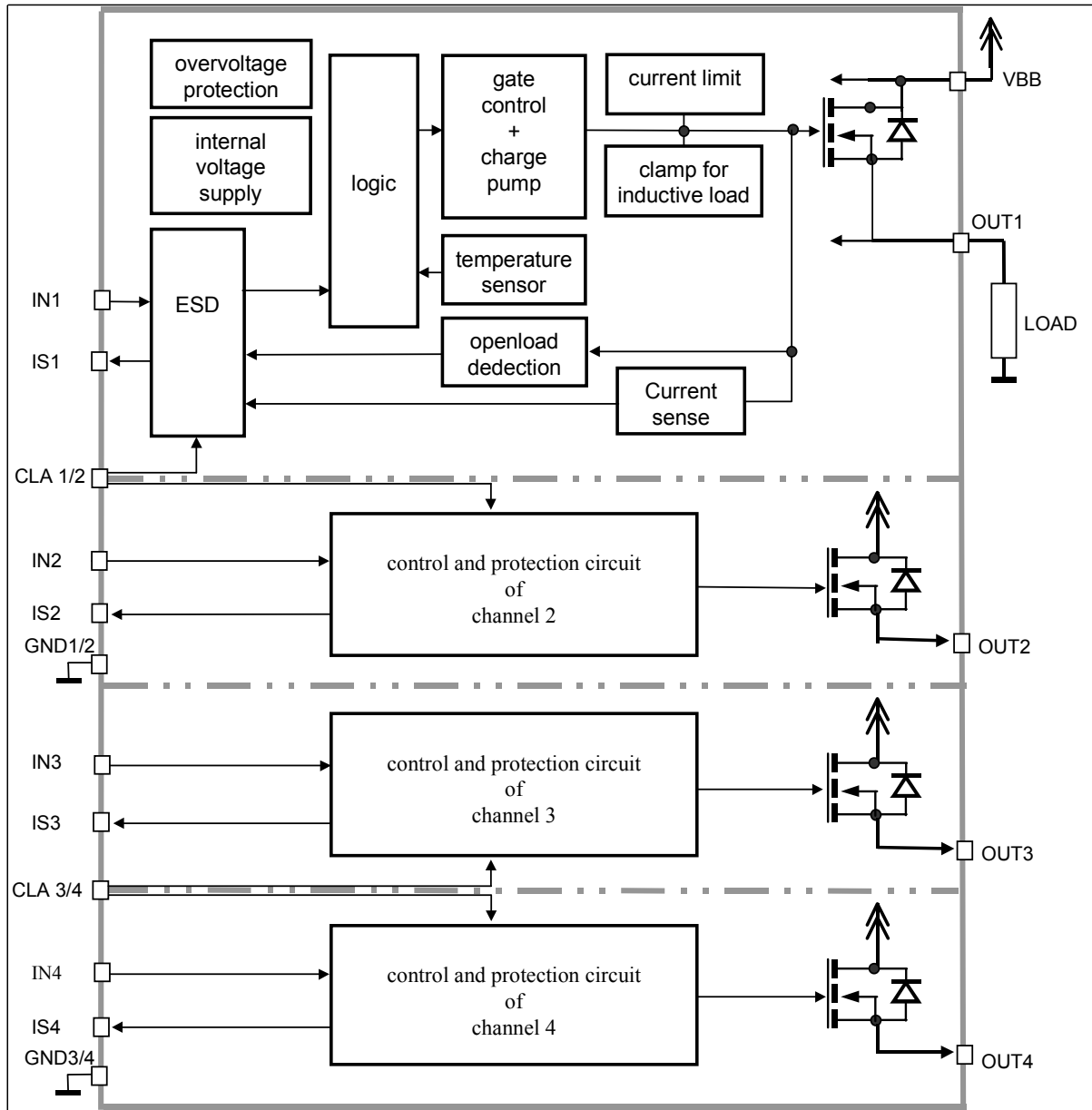

Pin definition and function

Pin	Symbol	Function
1,14, 15,28	V _{bb}	Positive power supply voltage. Design the wiring for the simultaneous max. short circuit currents from channel 1 to 4 and also for low thermal resistance
3	IN1	Input 1,2,3,4 activates channel 1,2,3,4 in case of logic high signal
6	IN2	
9	IN3	
12	IN4	
25,26,27	OUT1	Output 1,2,3,4 protected high-side power output of channel 1,2,3,4. Design the wiring for the max. short circuit current
22,23,24	OUT2	
19,20,21	OUT3	
16,17,18	OUT4	
4	IS1	Diagnostic feedback 1...4 of channel 1 to 4 On state: advanced current sense with defined signal in case of overload or short circuit Off state: High on failure
5	IS2	
10	IS3	
11	IS4	
7	CLA 1/2	Current limit adjust; the current limit for channels 1/2 and 3/4 can be chosen as high (potential < 2V) or low (potential > 4V).
13	CLA 3/4	
2	GND 1/2	Ground of chip 1 (channel 1,2)
8	GND 3/4	Ground of chip 2 (channel 3,4)

Pin configuration

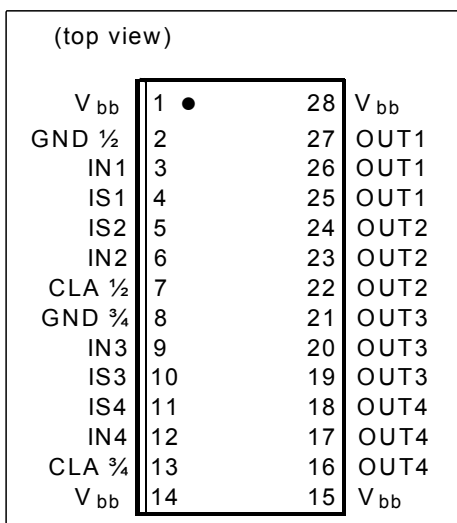

Maximum Ratings at $T_j=25^\circ\text{C}$, unless otherwise specified

Parameter	Symbol	Value	Unit
Supply voltage (overvoltage protection see page 6)	V_{bb}	28 ¹⁾	V
Supply voltage for full short circuit protection; $T_j = -40\dots150^\circ\text{C}$	$V_{bb(SC)}$	28 ²⁾	
Maximum voltage across DMOS	V_{ON}	52	
Load dump protection ³⁾ $V_{LoadDump} = V_A + V_S$; $V_A = 13,5\text{ V}$ In = low or high; $t_d = 400\text{ ms}$; R_I ⁴⁾ = $2\ \Omega$ $R_L = 2.25\ \Omega$ $R_L = 6.8\ \Omega$	$V_{LoadDump}$	40 53	
Load current (Short - circuit current, see page 7)	I_L	$I_{L(lim)}$ ⁵⁾	A
Operating temperature range	T_j	$-40\dots+150$	$^\circ\text{C}$
Storage temperature range	T_{stg}	$-55\dots+150$	
Dynamical temperature rise at switching	dT	60	K
Power dissipation ⁶⁾ (DC), all channels active $T_A = 85\ ^\circ\text{C}$	P_{tot}	1,6	W
Maximal switchable inductance, single pulse $V_{bb}=12\text{V}$, $T_{jstart}=150^\circ\text{C}$; (see diagrams on page 12) $I_L = 6\text{ A}$, $E_{AS} = 0.319\text{ J}$, $R_L = 0\ \Omega$, one channel: $I_L = 12\text{ A}$, $E_{AS} = 0.679\text{ J}$, $R_L = 0\ \Omega$, two parallel channels:	$Z_{L(s)}$	9.8 5.2	mH
Electrostatic discharge voltage (Human Body Model) according to ANSI EOS/ESD - S5.1 - 1993 , ESD STM5.1 - 1998	IN: V_{ESD} IS: OUT:	1,0 2,0 4,0	kV
Continuous input voltage	V_{IN}	$-10\dots16$	V
Voltage at current limit adjustment pin	V_{CLA}	$-10\dots16$	
Current through current limit adjustment pin	I_{CLA}	± 5.0	mA
Current through input pin (DC)	I_{IN}	± 5.0	
Current through sense pin (DC) (see page 11)	I_{IS}	$-5\dots+10$	

¹ 18...28 V for 100 hours

² only single pulse, $R_L = 200\text{ m}\Omega$; $L = 8\ \mu\text{H}$; R and L are describing the complete circuit impedance including line, contact and generator impedances.

³ Supply voltage higher than $V_{bb(AZ)}$ require an external current limit for the GND (150 Ω resistor) and sense pin.

⁴ R_I = internal resistance of the load dump test pulse generator.

⁵ Current limit is a protection function. Operation in current limitation is considered as "outside" normal operating range. Protection functions are not designed for continuous repetitive operation.

⁶ Device on 50mm*50mm*1.5mm epoxy PCB FR4 with 6 cm² (one layer, 70 μm thick) copper area for V_{bb} connection. PCB is vertical without blown air.

Electrical Characteristics

Parameter and Conditions, each of the four channels at $T_j = -40...+150\text{ °C}$, $V_{bb} = 9...16\text{ V}$, unless otherwise specified	Symbol	Values			Unit
		min.	typ.	max.	

Thermal Resistance

junction - soldering point ¹⁾ each channel:	R_{thJS}	-	-	25	K/W
junction - ambient ²⁾ one channel active:	R_{thJA}	-	40	-	K/W
		all channels active:			

Load Switching Capabilities and Characteristics

On-state resistance (V_{bb} to OUT), (see page 13) $T_j = 25\text{ °C}$, $I_L = 5\text{ A}$, each channel: $T_j = 150\text{ °C}$, each channel: $T_j = 25\text{ °C}$, two parallel channels: $T_j = 25\text{ °C}$, four parallel channels:	R_{ON}	-	21	25	mΩ
		-	42	50	
		-	11	13	
		-	5.5	6.5	
Nominal load current ²⁾ $T_a = 85\text{ °C}$, $T_j \leq 150\text{ °C}$, one channel active: two channels active, per channel: four channels active, per channel:	$I_{L(nom)}$	5.7	6.2	-	A
		4.0	4.4	-	
		3.1	3.4	-	
Output voltage drop limitation at small load currents $I_L = 0.5\text{ A}$	$V_{ON(NL)}$	-	40	-	mV
Output current while GND disconnected ³⁾ (see diagram page 12) $V_{IN} = 0\text{ V}$	$I_{L(GNDhigh)}$	-	-	2	mA

¹Soldering point is measured at V_{bb} -pin

²Device on 50mm*50mm*1.5mm epoxy PCB FR4 with 6 cm² (one layer, 70μm thick) copper area for V_{bb} connection. PCB is vertical without blown air.

³not subject to production test, specified by design

Electrical Characteristics

Parameter and Conditions, each of the four channels at $T_j = -40...+150\text{ °C}$, $V_{bb} = 9...16\text{ V}$, unless otherwise specified	Symbol	Values			Unit
		min.	typ.	max.	

Load Switching Capabilities and Characteristics

Turn-on time ¹⁾ to 90% V_{OUT} $R_L = 12\ \Omega$, $V_{bb} = 12\text{ V}$	t_{on}	-	90	200	μs
Turn-off time ¹⁾ to 10% V_{OUT} $R_L = 12\ \Omega$, $V_{bb} = 12\text{ V}$	t_{off}	-	100	220	
Slew rate on ¹⁾ 10 to 30% V_{OUT} , $R_L = 12\ \Omega$, $V_{bb} = 12\text{ V}$	dV/dt_{on}	0.1	0.25	0.45	$\text{V}/\mu\text{s}$
Slew rate off ¹⁾ 70 to 40% V_{OUT} , $R_L = 12\ \Omega$, $V_{bb} = 12\text{ V}$	$-dV/dt_{off}$	0.09	0.25	0.4	

Operating Parameters

Operating voltage ²⁾	$V_{bb(on)}$	4.5	-	28	V
Overvoltage protection ³⁾ $I_{bb} = 40\text{ mA}$	$V_{bb(AZ)}$	41	47	52	
Standby current ⁴⁾ (see diagram on page 13) $T_j = -40...+25\text{ °C}$, $V_{IN} = 0\text{ V}$ $T_j = 150\text{ °C}$	$I_{bb(off)}$	-	10	15	μA
		-	-	40	

¹See timing diagram on page 14.

²18V...28V for 100 hours

³Supply voltages higher than $V_{bb(AZ)}$ require an external current limit for the status pin and GND pin (e.g. $150\ \Omega$).
See also $V_{Out(CL)}$ in table of protection functions and circuit diagram on page 11.

⁴Measured with load; for the whole device; all channels off.

Electrical Characteristics

Parameter and Conditions, each of the four channels at $T_j = -40...+150\text{ }^\circ\text{C}$, $V_{bb} = 9...16\text{ V}$, unless otherwise specified	Symbol	Values			Unit
		min.	typ.	max.	

Operating Parameters

Off-State output current (included in $I_{bb(off)}$) $V_{IN} = 0\text{ V}$, each channel	$I_{L(off)}$	-	1.5	8	μA
Operating current ¹⁾ $V_{IN} = 5\text{ V}$, per active channel	I_{GND}	-	1.6	4	mA

Protection Functions²⁾

Current limit, (see timing diagrams, page 15) Low level; if potential at CLA = high High level; if potential at CLA = low	$I_{L(LIM)}$	7 40	11 50	14 60	A
Current limit adjustment threshold voltage	$V_{CLA(T-)}$ $V_{CLA(T+)}$	2.0 -	- -	- 4.0	V
Repetitive short circuit current limit $T_j = T_{jt}$ (see timing diagrams on page 15) High level Low level	$I_{L(SCr)}$	- -	40 40 7 7	- -	A
Initial short circuit shutdown time $T_{j,start} = 25^\circ\text{C}$; $V_{bb} = 13,5\text{ V}$	low level: high level: $t_{off(SC)}$	- -	3.5 0.75	- -	ms
Output clamp (inductive load switch off) ⁴⁾ $I_L = 40\text{ mA}$	$V_{Out(CL)}$	-	-15	-	V
Thermal overload trip temperature	T_{jt}	150	170	-	$^\circ\text{C}$
Thermal hysteresis	ΔT_{jt}	-	10	-	K

¹Add I_{IS} , if $I_{IS} > 0$

²Integrated protection functions are designed to prevent IC destruction under fault conditions described in the data sheet. Fault conditions are considered as "outside" normal operating range. Protection functions are not designed for continuous repetitive operation

³At the beginning of the short circuit the fourfold current is possible for a short time.

⁴If channels are connected in parallel, output clamp is usually accomplished by the channel with the lowest $V_{Out(CL)}$.

Electrical Characteristics

Parameter and Conditions, each of the four channels at $T_j = -40...+150\text{ °C}$, $V_{bb} = 9...16\text{ V}$, unless otherwise specified	Symbol	Values			Unit
		min.	typ.	max.	
Diagnostic Characteristics					
Open load detection voltage	$V_{OUT(OL)}$	2	3.2	4.4	V
Internal output pull down ¹⁾ $V_{OUT} = 13.5\text{ V}$	$R_{OUT(PD)}$	11	23	35	k Ω
Current sense ratio, static on-condition $k_{ILIS} = I_L : I_{IS}$ $I_L = 0.5\text{ A}$ $I_L = 3\text{ A}$ $I_L = 6\text{ A}$	k_{ILIS}	4640 4900 4900	5800 5400 5350	6960 5900 5800	
Sense signal in case of fault-conditions ²⁾ in off-state	V_{fault}	5	6.2	7.5	V
Current saturation of sense fault signal	I_{fault}	4	-	-	mA
Sense signal delay after thermal shutdown ³⁾	$t_{delay(fault)}$	-	-	1.2	ms
Current sense output voltage limitation $I_{IS} = 0$, $I_L = 5\text{ A}$	$V_{IS(lim)}$	5.4	6.5	7.3	V
Current sense leakage/offset current $V_{IN} = 5\text{ V}$, $I_L = 0$, $V_{IS} = 0$	$I_{IS(LH)}$	-	-	5	μA
Current sense settling time to I_{IS} static $\pm 10\%$ after positive input slope ⁴⁾ , $I_L = 0$ to 5A	$t_{son(IS)}$	-	-	400	μs
Current sense settling time to I_{IS} static $\pm 10\%$ after change of load current ⁴⁾ , $I_L = 2.5$ to 5A	$t_{slc(IS)}$	-	-	300	

¹In case of floating output, the status doesn't show open load.

²Fault condition means output voltage exceeds open load detection voltage $V_{OUT(OL)}$

³In the case of thermal shutdown the V_{fault} signal remains for $t_{delay(fault)}$ longer than the restart of the switch (see diagram on page 16). Not subject to production test, specified by design.

⁴not subject to production test, specified by design

Electrical Characteristics

Parameter	Symbol	Values			Unit
		min.	typ.	max.	
at $T_j = -40...+150\text{ °C}$, $V_{bb} = 9...16\text{ V}$, unless otherwise specified					

Diagnostic Characteristics

Status invalid after negative input slope	$t_{d(SToff)}$	-	-	1.2	ms
Status invalid after positive input slope with open load	$t_{d(STOL)}$	-	-	20	μs

Input Feedback¹⁾

Input resistance (see circuit page 11)	R_I	2.0	3.5	5.5	k Ω
Input turn-on threshold voltage	$V_{IN(T+)}$	-	-	2.4	V
Input turn-off threshold voltage	$V_{IN(T-)}$	1.0	-	-	
Input threshold hysteresis	$\Delta V_{IN(T)}$	-	0.5	-	
Off state input current $V_{IN} = 0.4\text{ V}$	$I_{IN(off)}$	3	-	40	μA
On state input current $V_{IN} = 5\text{ V}$	$I_{IN(on)}$	20	50	90	

Reverse Battery²⁾

Reverse battery voltage	$-V_{bb}$	-	-	27	V
Drain-source diode voltage ($V_{OUT} > V_{bb}$) $T_j = 150\text{ °C}$, $I_{bb} = -10\text{ mA}$	$-V_{ON}$	-	330	-	mV

¹If ground resistors R_{GND} are used, add the voltage drop across these resistor.

²Requires a 150 Ω resistor in GND connection. The reverse load current through the intrinsic drain-source diode has to be limited by the connected load. Power dissipation is higher compared to normal operating conditions due to the voltage drop across the drain-source diode. The temperature protection is not active during reverse current operation! Input and status currents have to be limited. (see max. ratings page 4)

Truth Table - for each of the four channels

	Input level	Output level	Diagnostic output
Normal Operation	L	L	Z ¹⁾
	H	V _{bb}	I _S = I _L / kilis
Current Limitation ²⁾	H	V _{bb}	V _{fault}
Short circuit to GND	L	L	Z ¹⁾
	H	L	V _{fault}
Overtemperature	L	L	Z ¹⁾
	H	L	V _{fault}
Short circuit to V _{bb}	L	V _{bb}	V _{fault}
	H	V _{bb}	< I _S = I _L / kilis ³⁾
Open load	L	> V _{out(OL)}	V _{fault}
	H	V _{bb}	Z ¹⁾

L = " Low" Level Z = high impedance, potential depends on external circuit
H = "High" Level V_{fault} = 5V typ., constant voltage independent of external sense resistor.
Parallel switching of channels is possible by connecting the inputs and outputs parallel.
The current sense outputs have to be connected with a single sense resistor.

Terms

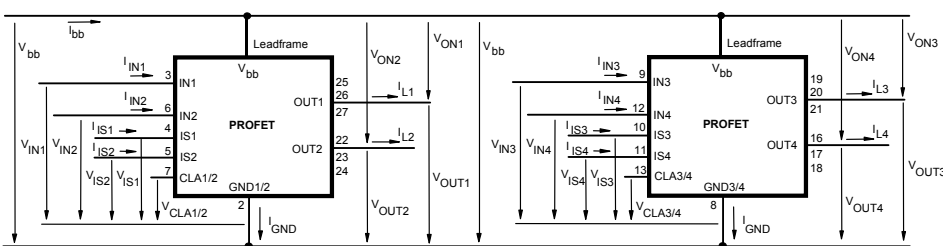

Leadframe (V_{bb}) is connected to pin 1, 14, 15, 28

- ¹L-potential by using a sense resistor
- ²Current limitation is only possible while the device is switched on.
- ³Low ohmic short to V_{bb} may reduce the output current I_L and therefore also the sense current I_S.

Input circuit (ESD protection), IN1...IN4

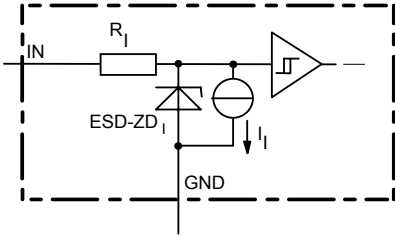

The use of ESD zener diodes as voltage clamp at DC conditions is not recommended.

Sense-Status output, IS1...IS4

ON-State: Normal operation: $I_S = I_L / \text{kILIS}$

$V_{IS} = I_S * R_{IS}; R_{IS} = 1\text{k}\Omega$ nominal
 $R_{IS} > 500\Omega$

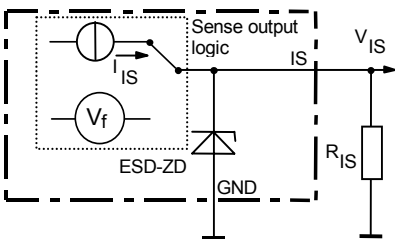

ESD zener diode: $V_{ESD} = 6,1\text{ V typ.}, \text{max. } 14\text{ mA}$;
 ON-State: Fault condition so as thermal shut down or current limitation

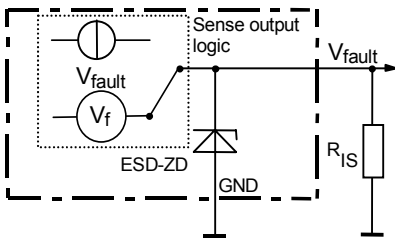

$V_{\text{fault}} = 6\text{ V typ}; V_{\text{fault}} < V_{ESD}$ under all conditions

OFF-State diagnostic condition:
 Open Load, if $V_{OUT} > 3\text{ V typ.}; \text{IN low}$

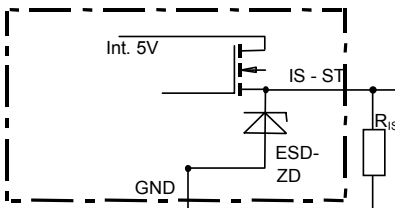

ESD-Zener diode: $6,1\text{V typ.}, \text{max. } 5\text{mA}; R_{ST(ON)} < 375\Omega$
 at $1,6\text{mA}$.. The use of ESD zener diodes as voltage clamp at DC conditions is not recommended.

Inductive and overvoltage output clamp, OUT1...OUT4

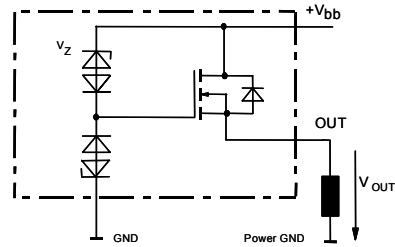

V_{Out} clamped to $V_{\text{Out(CL)}} = -15\text{ V typ.}$

Overvolt. Protection of logic part OUT1...OUT4

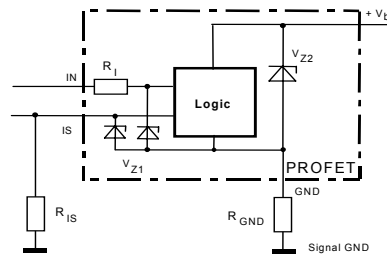

$V_{Z1} = 6,1\text{V typ.}, V_{Z2} = 47\text{V typ.}, R_{GND} = 150\Omega$,
 $R_{IS} = 1\text{k}\Omega$, $R_I = 3,5\text{k}\Omega$ typ.

Reverse battery protection
OUT1...OUT4

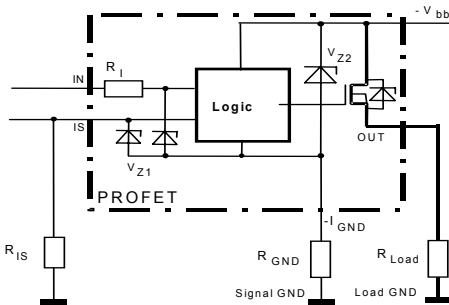

$V_{Z1} = 6,1V$ typ., $V_{Z2} = 47V$ typ., $R_{GND} = 150\Omega$
 $R_{IS} = 1k\Omega$, $R_1 = 3,5k\Omega$ typ.

In case of reverse battery the load current has to be limited by the load. Protection functions are not active.

Open load detection, OUT1...OUT4

Off-state diagnostic condition:
 Open load, if $V_{OUT} > 3 V$ typ.; IN = low

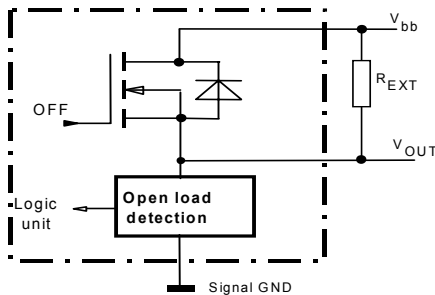

GND disconnect

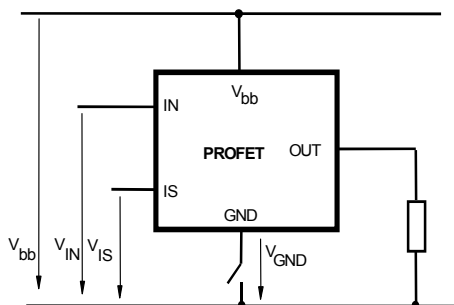

Any kind of load.

Vbb disconnect with energized inductive load

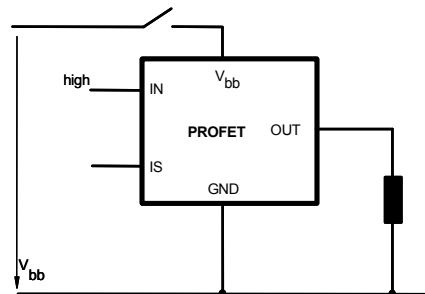

For inductive load currents up to the limits defined by Z_L each switch is protected against loss of V_{bb} . (max. ratings and diagram on page 12)
 Consider at your PCB layout that in the case of V_{bb} disconnection with energized inductive load all the load current flows through the GND connection.

Inductive load switch-off energy dissipation

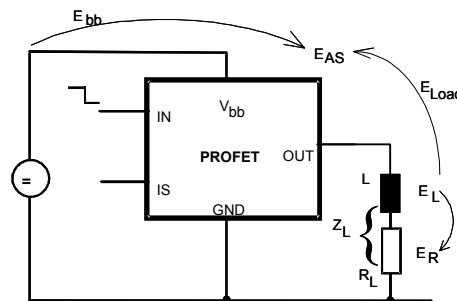

Energy stored in load inductance: $E_L = \frac{1}{2} * L * I_L^2$

While demagnetizing load inductance, the energy dissipated in PROFET is $E_{AS} = E_{bb} + E_L - E_R = V_{ON(CL)} * i_L(t) dt$, with an approximate solution for $R_L > 0\Omega$:

$$E_{AS} = \frac{I_L * L}{2 * R_L} * (V_{bb} + |V_{OUT(CL)}|) * \ln\left(1 + \frac{I_L * R_L}{|V_{OUT(CL)}|}\right)$$

**Maximum allowable load inductance
for a single switch off (one channel)**

$L = f(I_L); T_{jstart} = 150^{\circ}\text{C}, V_{bb} = 12\text{V}, R_L = 0\Omega$

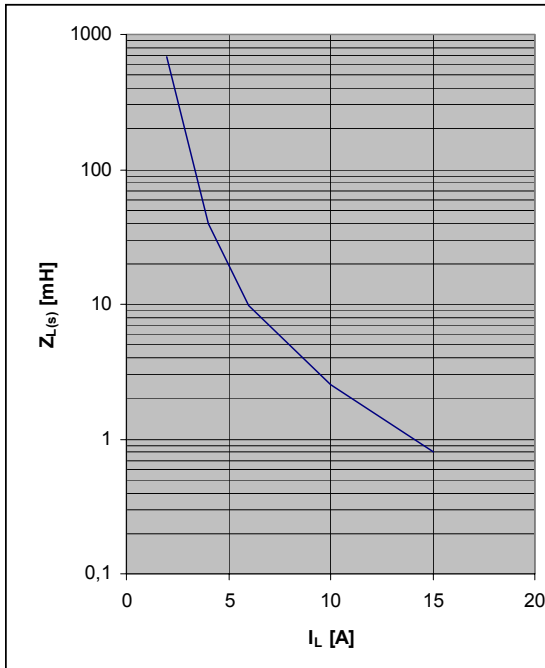

Typ. standby current

$I_{bb(off)} = f(T_j); V_{bb} = 16\text{V}; V_{IN1...4} = \text{low}$

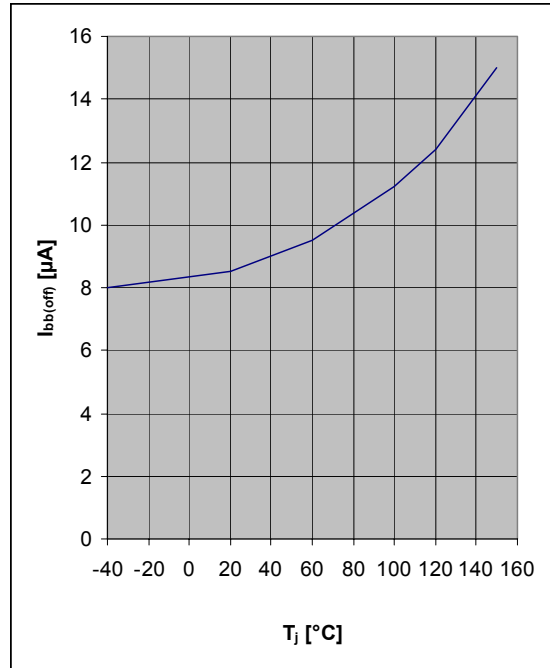

Typ. on-state resistance

$R_{ON} = f(V_{bb}, T_j); I_L = 5\text{A}; V_{in} = \text{high}$

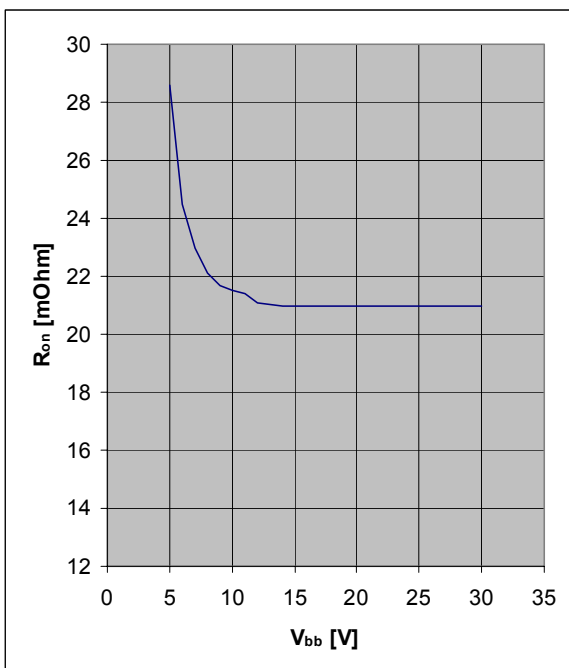

Timing diagrams

All channels are symmetric and consequently the diagrams are valid for channel 1 to channel 4.

Figure 1a: Switching a resistive load, change of load current in on-condition

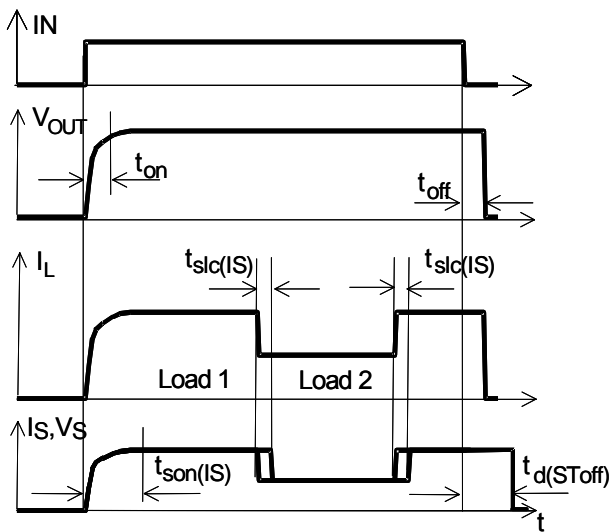

The sense signal is not valid during settling time after turn on or change of load current. $t_{slc}(I_S) = 300 \mu s$ max.

Figure 1b: V_{bb} turn on

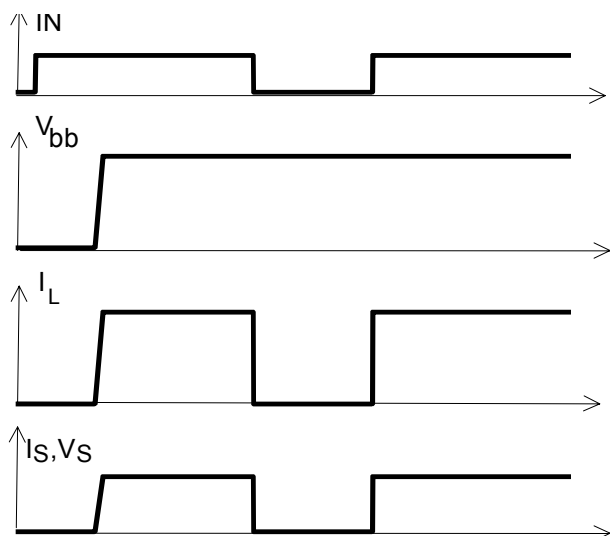

proper turn on under all conditions

Figure 1c: Behaviour of sense output: Sense current (I_S) and sense voltage (V_S) as function of load current dependent on the sense resistor. Shown is V_S and I_S for three different sense resistors. Curve 1 refers to a low resistor, curve 2 to a medium-sized resistor and curve 3 to a big resistor. Note, that the sense resistor may not falls short of a minimum value of 500Ω .

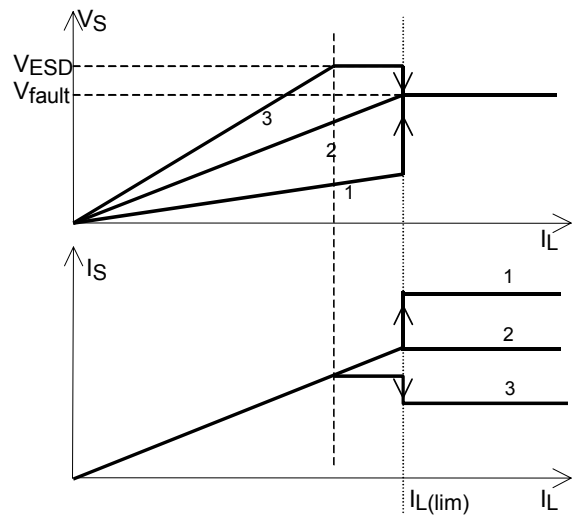

$$I_S = I_L / k_{ILIS}$$

$$V_{IS} = I_S * R_{IS}; R_{IS} = 1k\Omega \text{ nominal}$$

$$R_{IS} > 500\Omega$$

Figure 2a: Switching a lamp

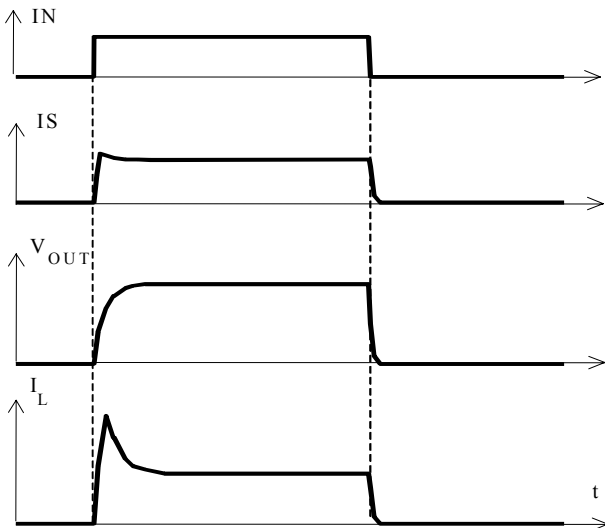

Figure 2b: Switching a lamp with current limit: The behaviour of I_S and V_S is shown for a resistor, which refers to curve 1 in figure 1c

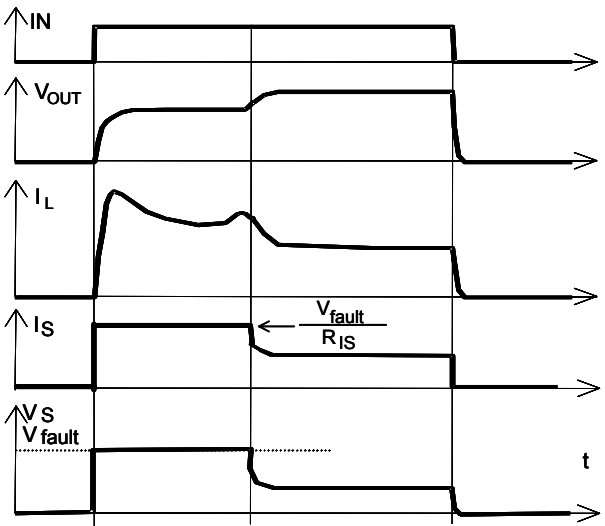
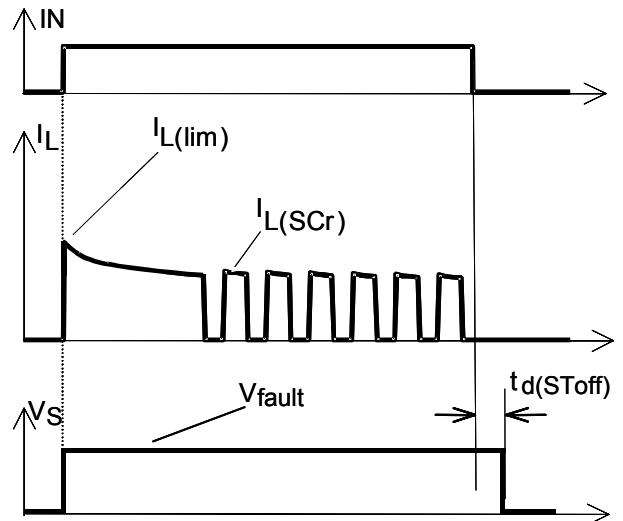

Figure 3a: Short circuit: Shut down by overtemperature, reset by cooling



Heating up may require several milliseconds, depending on external conditions.
 $I_{L(lim)} = 50A$ typ. increases with decreasing temperature.

Figure 3b: Turn on into short circuit, shut down by overtemperature, restart by cooling (channel 1 and 2 switched parallel)

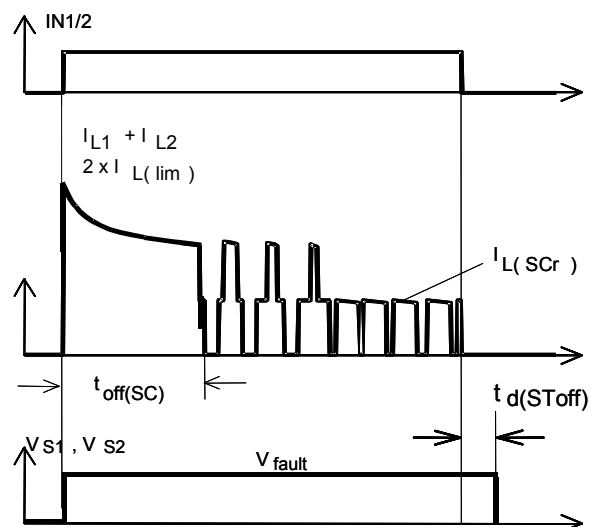

Figure 4a: Overtemperature

Reset if $T_j < T_{jt}$

The behaviour of I_S and V_S is shown for a resistor, which refers to curve 1 in figure 1c.

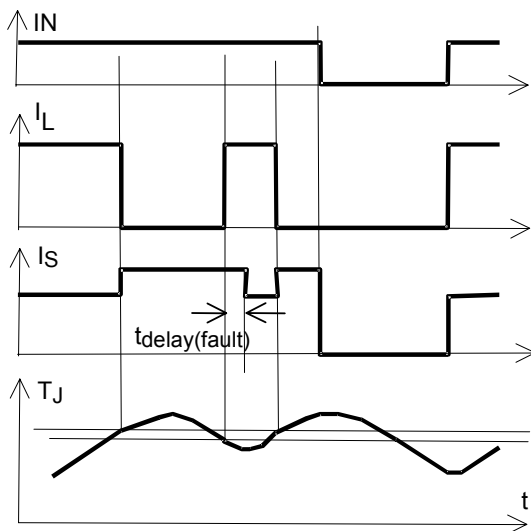

Figure 6a: Current sense ratio¹⁾

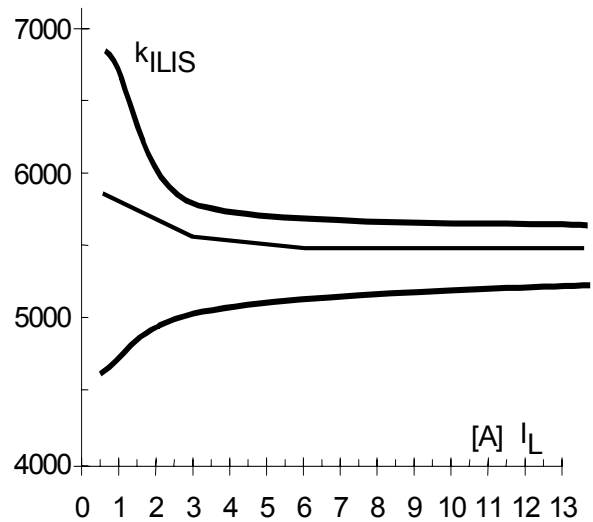
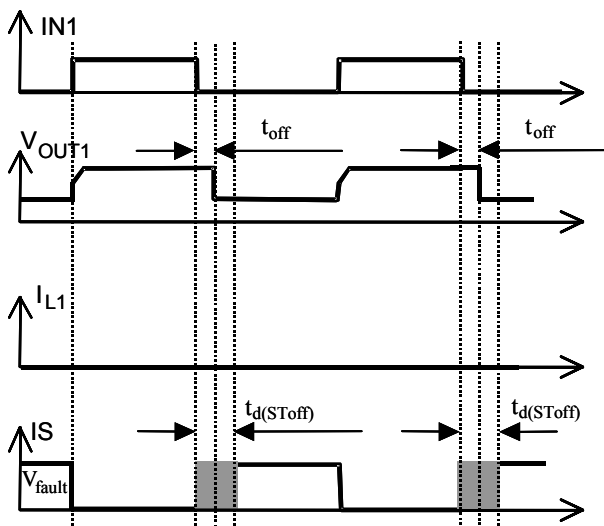

Figure 5a: Open-load: detection in OFF-state, turn on/off to open load.

Open load of channel 1; other channels normal operation.



$t_{off} = 220\mu s$ max.; $t_d(SToff) = 1,2ms$ max.

with pull up resistor at output

¹This range for the current sense ratio refers to all devices. The accuracy of the k_{ILIS} can be raised by calibrating the value of k_{ILIS} for every single device.

Package and ordering code

all dimensions in mm

P-DSO-28-19

Sales Code	BTS 5440G
Ordering Code	Q67060-S6136

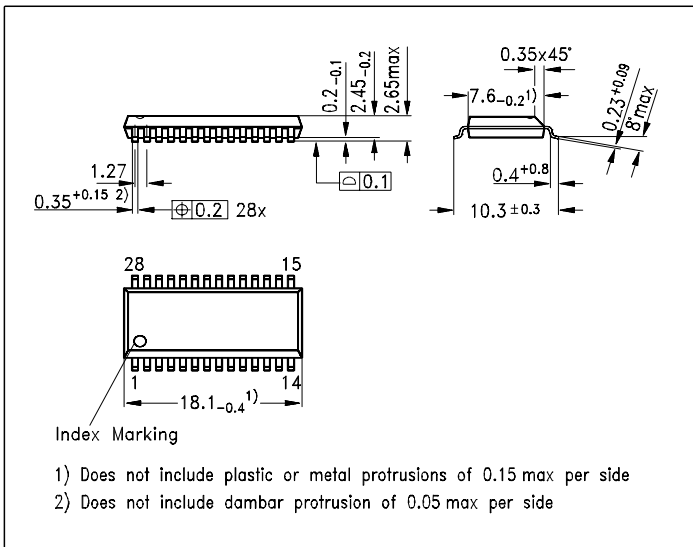

Published by
Infineon Technologies AG,
St.-Martin-Strasse 53,
D-81669 München
© Infineon Technologies AG 2001
All Rights Reserved.

Attention please!

The information herein is given to describe certain components and shall not be considered as a guarantee of characteristics.

Terms of delivery and rights to technical change reserved.

We hereby disclaim any and all warranties, including but not limited to warranties of non-infringement, regarding circuits, descriptions and charts stated herein.

Infineon Technologies is an approved CECC manufacturer.

Information

For further information on technology, delivery terms and conditions and prices please contact your nearest Infineon Technologies Office in Germany or our Infineon Technologies Representatives worldwide (see address list).

Warnings

Due to technical requirements components may contain dangerous substances. For information on the types in question please contact your nearest Infineon Technologies Office.

Infineon Technologies Components may only be used in life-support devices or systems with the express written approval of Infineon Technologies, if a failure of such components can reasonably be expected to cause the failure of that life-support device or system, or to affect the safety or effectiveness of that device or system. Life support devices or systems are intended to be implanted in the human body, or to support and/or maintain and sustain and/or protect human life. If they fail, it is reasonable to assume that the health of the user or other persons may be endangered.

Looking for pricing, stock, or lifecycle information?

Click below to explore more details on WIN SOURCE:

-  [View BTS5440GXUMA1 on WIN SOURCE](#)
-  [Infineon Technologies Information](#)

Optimize Your Supply Chain with WIN SOURCE Solutions

-  Global Sourcing Solution
-  Obsolete Management
-  Cost Control Management
-  Shortage Management
-  Alternative Solution
-  Excess Inventory Management