



**THE DATASHEET OF  
NLV74VHC595DTR2G**



# 8-Bit Shift Register with Output Storage Register

(3-State)

## MC74VHC595

The MC74VHC595 is an advanced high speed 8-bit shift register with an output storage register fabricated with silicon gate CMOS technology.

It achieves high speed operation similar to equivalent Bipolar Schottky TTL while maintaining CMOS low power dissipation.

The MC74VHC595 contains an 8-bit static shift register which feeds an 8-bit storage register.

Shift operation is accomplished on the positive going transition of the Shift Clock input (SCK). The output register is loaded with the contents of the shift register on the positive going transition of the Register Clock input (RCK). Since the RCK and SCK signals are independent, parallel outputs can be held stable during the shift operation. And, since the parallel outputs are 3-state, the VHC595 can be directly connected to an 8-bit bus. This register can be used in serial-to-parallel conversion, data receivers, etc.

The internal circuit is composed of three stages, including a buffer output which provides high noise immunity and stable output. The inputs tolerate voltages up to 5.5 V, allowing the interface of 5 V systems to 3 V systems.

### Features

- High Speed:  $f_{max} = 185$  MHz (Typ) at  $V_{CC} = 5$  V
- Low Power Dissipation:  $I_{CC} = 4$   $\mu$ A (Max) at  $T_A = 25^\circ$ C
- High Noise Immunity:  $V_{NIH} = V_{NIL} = 28\%$   $V_{CC}$
- Power Down Protection Provided on Inputs
- Balanced Propagation Delays
- Designed for 2 V to 5.5 V Operating Range
- Low Noise:  $V_{OLP} = 1.0$  V (Max)
- Pin and Function Compatible with Other Standard Logic Families
- Latchup Performance Exceeds 300 mA
- ESD Performance: HBM > 2000 V; Machine Model > 200 V
- -Q Suffix for Automotive and Other Applications Requiring Unique Site and Control Change Requirements; AEC-Q100 Qualified and PPAP Capable
- These Devices are Pb-Free and are RoHS Compliant

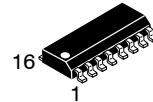

SOIC-16  
D SUFFIX  
CASE 751B

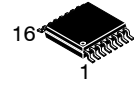

TSSOP-16  
DT SUFFIX  
CASE 948F



QFN16  
MN SUFFIX  
CASE 485AW

### MARKING DIAGRAMS

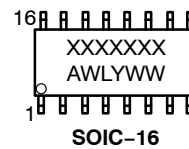

SOIC-16

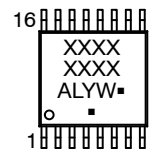

TSSOP-16



QFN16

XXXXXXXX = Specific Device Code

A = Assembly Location

WL, L = Wafer Lot

Y = Year

WW, W = Work Week

G or ■ = Pb-Free Package

(Note: Microdot may be in either location)

### ORDERING INFORMATION

See detailed ordering, marking and shipping information in the package dimensions section on page 10 of this data sheet.

# MC74VHC595

## LOGIC DIAGRAM

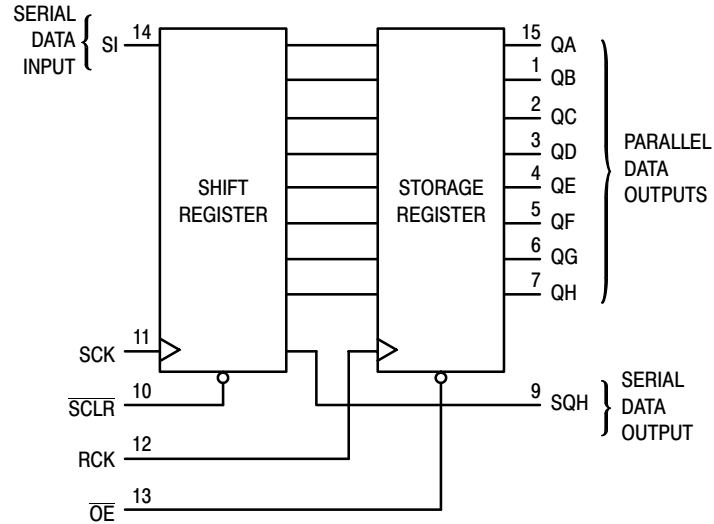

## IEC LOGIC SYMBOL

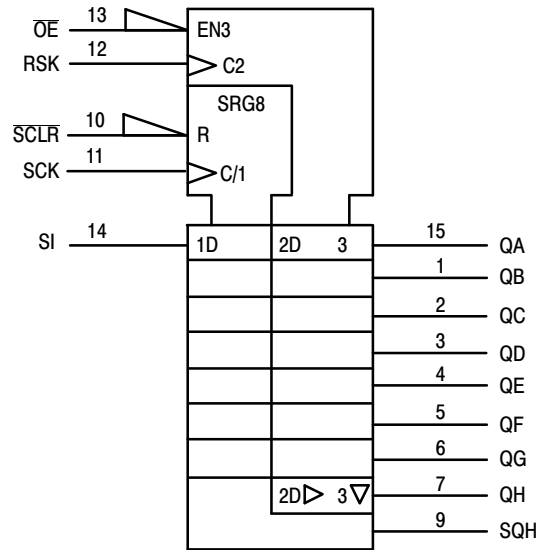

# MC74VHC595

## FUNCTION TABLE

Operation	Inputs					Resulting Function			
	Reset (SCLR)	Serial Input (SI)	Shift Clock (SCK)	Reg Clock (RCK)	Output Enable (OE)	Shift Register Contents	Storage Register Contents	Serial Output (SQH)	Parallel Outputs (QA – QH)
Clear shift register	L	X	X	L, H, ↓	L	L	U	L	U
Shift data into shift register	H	D	↑	L, H, ↓	L	D → SR <sub>A</sub> ; SR <sub>N</sub> → SR <sub>N+1</sub>	U	SR <sub>G</sub> → SR <sub>H</sub>	U
Registers remains unchanged	H	X	L, H, ↓	X	L	U	**	U	**
Transfer shift register contents to storage register	H	X	L, H, ↓	↑	L	U	SR <sub>N</sub> → STR <sub>N</sub>	*	SR <sub>N</sub>
Storage register remains unchanged	X	X	X	L, H, ↓	L	*	U	*	U
Enable parallel outputs	X	X	X	X	L	*	**	*	Enabled
Force outputs into high impedance state	X	X	X	X	H	*	**	*	Z

SR = shift register contents      D = data (L, H) logic level      ↓ = High-to-Low      \* = depends on Reset and Shift Clock inputs  
 STR = storage register contents      U = remains unchanged      ↑ = Low-to-High      \*\* = depends on Register Clock input

## MAXIMUM RATINGS

Symbol	Parameter	Value	Unit
V <sub>CC</sub>	DC Supply Voltage	-0.5 to +6.5	V
V <sub>IN</sub>	DC Input Voltage	-0.5 to +6.5	V
V <sub>OUT</sub>	DC Output Voltage	-0.5 to V <sub>CC</sub> +0.5	V
I <sub>IN</sub>	DC Input Current, per Pin	±20	mA
I <sub>OUT</sub>	DC Output Current, per Pin	±25	mA
I <sub>CC</sub>	DC Supply Current, V <sub>CC</sub> and GND Pins	±50	mA
I <sub>IK</sub>	Input Clamp Current	-20	mA
I <sub>OK</sub>	Output Clamp Current	±20	mA
T <sub>STG</sub>	Storage Temperature Range	-65 to +150	°C
T <sub>L</sub>	Lead Temperature, 1 mm from Case for 10 Seconds	260	°C
T <sub>J</sub>	Junction Temperature Under Bias	+150	°C
θ <sub>JA</sub>	Thermal Resistance (Note 2)	SOIC-16      126 QFN16      118 TSSOP-16      159	°C/W
P <sub>D</sub>	Power Dissipation in Still Air at 25°C	SOIC-16      995 QFN16      1062 TSSOP-16      787	mW
MSL	Moisture Sensitivity	Level 1	-
F <sub>R</sub>	Flammability Rating	Oxygen Index: 28 to 34	UL 94 V-0 @ 0.125 in.
V <sub>ESD</sub>	ESD Withstand Voltage (Note 3)	Human Body Model Charged Device Model	2000 N/A

Stresses exceeding those listed in the Maximum Ratings table may damage the device. If any of these limits are exceeded, device functionality should not be assumed, damage may occur and reliability may be affected.

1. Applicable to devices with outputs that may be tri-stated.
2. Measured with minimum pad spacing on an FR4 board, using 76mm-by-114mm, 2-ounce copper trace no air flow per JESD51-7.
3. HBM tested to EIA / JESD22-A114-A. CDM tested to JESD22-C101-A. JEDEC recommends that ESD qualification to EIA/JESD22-A115A (Machine Model) be discontinued.

# MC74VHC595

## RECOMMENDED OPERATING CONDITIONS

Symbol	Parameter	Min	Max	Unit
$V_{CC}$	DC Supply Voltage	2.0	5.5	V
$V_{IN}$	DC Input Voltage (Note 4)	0	5.5	V
$V_{OUT}$	DC Output Voltage (Note 4)	0	$V_{CC}$	V
$T_A$	Operating Temperature	-55	+125	°C
$t_r, t_f$	Input Rise or Fall Rate	$V_{CC} = 3.0\text{ V to }3.6\text{ V}$ $V_{CC} = 4.5\text{ V to }5.5\text{ V}$	100 20	ns/V

Functional operation above the stresses listed in the Recommended Operating Ranges is not implied. Extended exposure to stresses beyond the Recommended Operating Ranges limits may affect device reliability.

4. Unused inputs must always be tied to an appropriate logic voltage level (e.g., either GND or  $V_{CC}$ ). Unused outputs must be left open.

## DC ELECTRICAL CHARACTERISTICS

Symbol	Parameter	Test Conditions	$V_{CC}$ (V)	$T_A = 25^\circ\text{C}$			$T_A = \leq 85^\circ\text{C}$		$T_A = \leq 125^\circ\text{C}$		Unit
				Min	Typ	Max	Min	Max	Min	Max	
$V_{IH}$	Minimum High-Level Input Voltage		2.0	1.5			1.5		1.5		V
			3.0	2.1			2.1		2.1		
			4.5	3.15			3.15		3.15		
			5.5	3.85			3.85		3.85		
$V_{IL}$	Maximum Low-Level Input Voltage		2.0			0.5		0.5		0.5	V
			3.0			0.9		0.9		0.9	
			4.5			1.35		1.35		1.35	
			5.5			1.65		1.65		1.65	
$V_{OH}$	Minimum High-Level Output Voltage $V_{IN} = V_{IH}$ or $V_{IL}$	$V_{IN} = V_{IH}$ or $V_{IL}$ $I_{OH} = -50\ \mu\text{A}$	2.0	1.9	2.0		1.9		1.9		V
			3.0	2.9	3.0		2.9		2.9		
		4.5	4.4	4.5		4.4		4.4			
		$V_{IN} = V_{IH}$ or $V_{IL}$ $I_{OH} = -4\ \text{mA}$ $I_{OH} = -8\ \text{mA}$	3.0	2.58			2.48		2.34		
			4.5	3.94			3.80		3.66		
$V_{OL}$	Maximum Low-Level Output Voltage $V_{IN} = V_{IH}$ or $V_{IL}$	$V_{IN} = V_{IH}$ or $V_{IL}$ $I_{OL} = 50\ \mu\text{A}$	2.0		0.0	0.1		0.1		0.1	V
			3.0		0.0	0.1		0.1		0.1	
		4.5		0.0	0.1		0.1		0.1		
		$V_{IN} = V_{IH}$ or $V_{IL}$ $I_{OL} = 4\ \text{mA}$ $I_{OL} = 8\ \text{mA}$	3.0			0.36		0.44		0.52	
			4.5			0.36		0.44		0.52	
$I_{IN}$	Maximum Input Leakage Current	$V_{IN} = 5.5\ \text{V}$ or GND	0 to 5.5			$\pm 0.1$		$\pm 1.0$		$\pm 1.0$	$\mu\text{A}$
$I_{CC}$	Maximum Quiescent Supply Current	$V_{IN} = V_{CC}$ or GND	5.5			4.0		40.0		40.0	$\mu\text{A}$
$I_{OZ}$	Three-State Output Off-State Current	$V_{IN} = V_{IH}$ or $V_{IL}$ $V_{OUT} = V_{CC}$ or GND	5.5			$\pm 0.25$		$\pm 2.5$		$\pm 2.5$	$\mu\text{A}$

Product parametric performance is indicated in the Electrical Characteristics for the listed test conditions, unless otherwise noted. Product performance may not be indicated by the Electrical Characteristics if operated under different conditions.

# MC74VHC595

## AC ELECTRICAL CHARACTERISTICS

Symbol	Parameter	Test Conditions	T <sub>A</sub> = 25°C			T <sub>A</sub> = ≤ 85°C		T <sub>A</sub> = ≤ 125°C		Unit
			Min	Typ	Max	Min	Max	Min	Max	
f <sub>max</sub>	Maximum Clock Frequency (50% Duty Cycle)	V <sub>CC</sub> = 3.3 ± 0.3 V	80	150		70		70		MHz
		V <sub>CC</sub> = 5.0 ± 0.5 V	135	185		115		115		
t <sub>PLH</sub> , t <sub>PHL</sub>	Propagation Delay, SCK to SQH	V <sub>CC</sub> = 3.3 ± 0.3 V C <sub>L</sub> = 15pF C <sub>L</sub> = 50pF		8.8 11.3	13.0 16.5	1.0 1.0	15.0 18.5	1.0 1.0	15.0 18.5	ns
		V <sub>CC</sub> = 5.0 ± 0.5 V C <sub>L</sub> = 15pF C <sub>L</sub> = 50pF		6.2 7.7	8.2 10.2	1.0 1.0	9.4 11.4	1.0 1.0	9.4 11.4	
t <sub>PHL</sub>	Propagation Delay, CPLR to SQH	V <sub>CC</sub> = 3.3 ± 0.3 V C <sub>L</sub> = 15pF C <sub>L</sub> = 50pF		8.4 10.9	12.8 16.3	1.0 1.0	13.7 17.2	1.0 1.0	13.7 17.2	ns
		V <sub>CC</sub> = 5.0 ± 0.5 V C <sub>L</sub> = 15pF C <sub>L</sub> = 50pF		5.9 7.4	8.0 10.0	1.0 1.0	9.1 11.1	1.0 1.0	9.1 11.1	
t <sub>PLH</sub> , t <sub>PHL</sub>	Propagation Delay, RCK to QA–QH	V <sub>CC</sub> = 3.3 ± 0.3 V C <sub>L</sub> = 15pF C <sub>L</sub> = 50pF		7.7 10.2	11.9 15.4	1.0 1.0	13.5 17.0	1.0 1.0	13.5 17.0	ns
		V <sub>CC</sub> = 5.0 ± 0.5 V C <sub>L</sub> = 15pF C <sub>L</sub> = 50pF		5.4 6.9	7.4 9.4	1.0 1.0	8.5 10.5	1.0 1.0	8.5 10.5	
t <sub>PZL</sub> , t <sub>PZH</sub>	Output Enable Time, OE to QA–QH	V <sub>CC</sub> = 3.3 ± 0.3 V C <sub>L</sub> = 15pF C <sub>L</sub> = 50pF		7.5 9.0	11.5 15.0	1.0 1.0	13.5 17.0	1.0 1.0	13.5 17.0	ns
		V <sub>CC</sub> = 5.0 ± 0.5 V C <sub>L</sub> = 15pF C <sub>L</sub> = 50pF		4.8 8.3	8.6 10.6	1.0 1.0	10.0 12.0	1.0 1.0	10.0 12.0	
t <sub>PLZ</sub> , t <sub>PHZ</sub>	Output Disable Time, OE to QA–QH	V <sub>CC</sub> = 3.3 ± 0.3 V C <sub>L</sub> = 50pF		12.1	15.7	1.0	16.2	1.0	16.2	ns
		V <sub>CC</sub> = 5.0 ± 0.5 V C <sub>L</sub> = 50pF		7.6	10.3	1.0	11.0	1.0	11.0	
C <sub>IN</sub>	Input Capacitance			4	10		10		10	pF
C <sub>OUT</sub>	Three-State Output Capacitance (Output in High-Impedance State), QA–QH			6			10		10	pF

C <sub>PD</sub>	Power Dissipation Capacitance (Note 5)	Typical @ 25°C, V <sub>CC</sub> = 5.0 V		pF
		87		

5. C<sub>PD</sub> is defined as the value of the internal equivalent capacitance which is calculated from the operating current consumption without load. Average operating current can be obtained by the equation: I<sub>CC(OPR)</sub> = C<sub>PD</sub> • V<sub>CC</sub> • f<sub>in</sub> + I<sub>CC</sub>. C<sub>PD</sub> is used to determine the no-load dynamic power consumption; P<sub>D</sub> = C<sub>PD</sub> • V<sub>CC</sub><sup>2</sup> • f<sub>in</sub> + I<sub>CC</sub> • V<sub>CC</sub>.

## NOISE CHARACTERISTICS (C<sub>L</sub> = 50 pF, V<sub>CC</sub> = 5.0 V)

Symbol	Characteristic	T <sub>A</sub> = 25°C		Unit
		Typ	Max	
V <sub>OLP</sub>	Quiet Output Maximum Dynamic V <sub>OL</sub>	0.8	1.0	V
V <sub>OLV</sub>	Quiet Output Minimum Dynamic V <sub>OL</sub>	-0.8	-1.0	V
V <sub>IHD</sub>	Minimum High Level Dynamic Input Voltage		3.5	V
V <sub>ILD</sub>	Maximum Low Level Dynamic Input Voltage		1.5	V

# MC74VHC595

## TIMING REQUIREMENTS

Symbol	Parameter	V <sub>CC</sub> V	T <sub>A</sub> = 25°C		T <sub>A</sub> = - 40 to 85°C	T <sub>A</sub> = - 55 to 125°C	Unit
			Typ	Limit	Limit	Limit	
t <sub>SU</sub>	Setup Time, SI to SCK	3.3 5.0		3.5 3.0	3.5 3.0	3.5 3.0	ns
t <sub>SU(H)</sub>	Setup Time, SCK to RCK	3.3 5.0		8.0 5.0	8.5 5.0	8.5 5.0	ns
t <sub>SU(L)</sub>	Setup Time, $\overline{\text{SCLR}}$ to RCK	3.3 5.0		8.0 5.0	9.0 5.0	9.0 5.0	ns
t <sub>H</sub>	Hold Time, SI to SCK	3.3 5.0		1.5 2.0	1.5 2.0	1.5 2.0	ns
t <sub>H(L)</sub>	Hold Time, $\overline{\text{SCLR}}$ to RCK	3.3 5.0		0 0	0 0	1.0 1.0	ns
t <sub>REC</sub>	Recovery Time, $\overline{\text{SCLR}}$ to SCK	3.3 5.0		3.0 2.5	3.0 2.5	3.0 2.5	ns
t <sub>W</sub>	Pulse Width, SCK or RCK	3.3 5.0		5.0 5.0	5.0 5.0	5.0 5.0	ns
t <sub>W(L)</sub>	Pulse Width, $\overline{\text{SCLR}}$	3.3 5.0		5.0 5.0	5.0 5.0	5.0 5.0	ns

# MC74VHC595

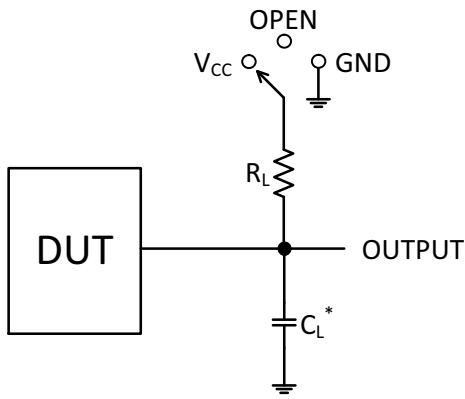

\*C<sub>L</sub> Includes probe and jig capacitance  
Input t<sub>R</sub> = t<sub>F</sub> = 3 ns

Test	Switch Position	C <sub>L</sub>	R <sub>L</sub>
t <sub>PLH</sub> / t <sub>PHL</sub>	Open	See AC Characteristics Table	1 kΩ
t <sub>PLZ</sub> / t <sub>PZL</sub>	V <sub>CC</sub>		
t <sub>PHZ</sub> / t <sub>PZH</sub>	GND		

Figure 1. Test Circuit

## SWITCHING WAVEFORMS

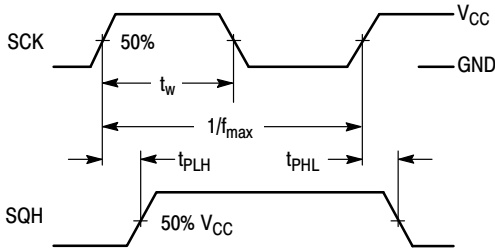

Figure 2.

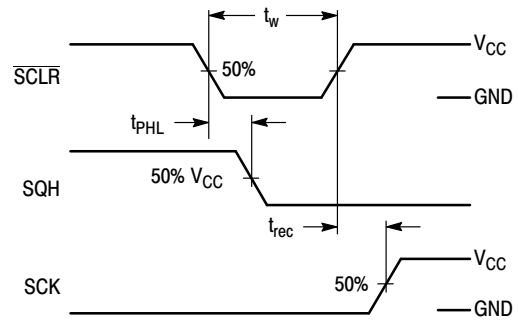

Figure 3.

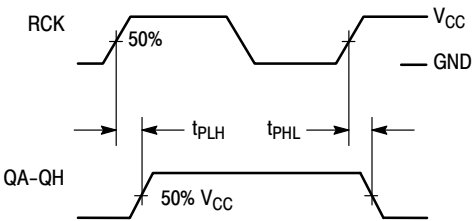

Figure 4.

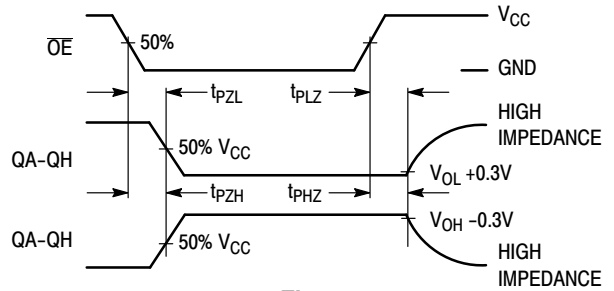

Figure 5.

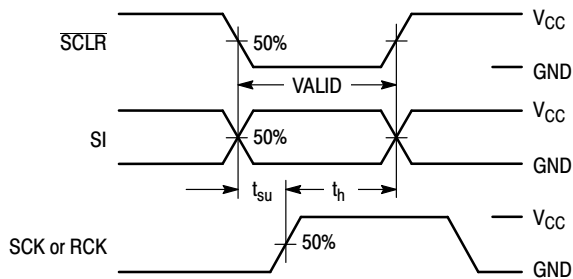

Figure 6.

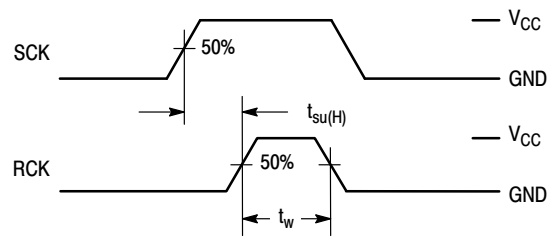

Figure 7.

# MC74VHC595

## EXPANDED LOGIC DIAGRAM

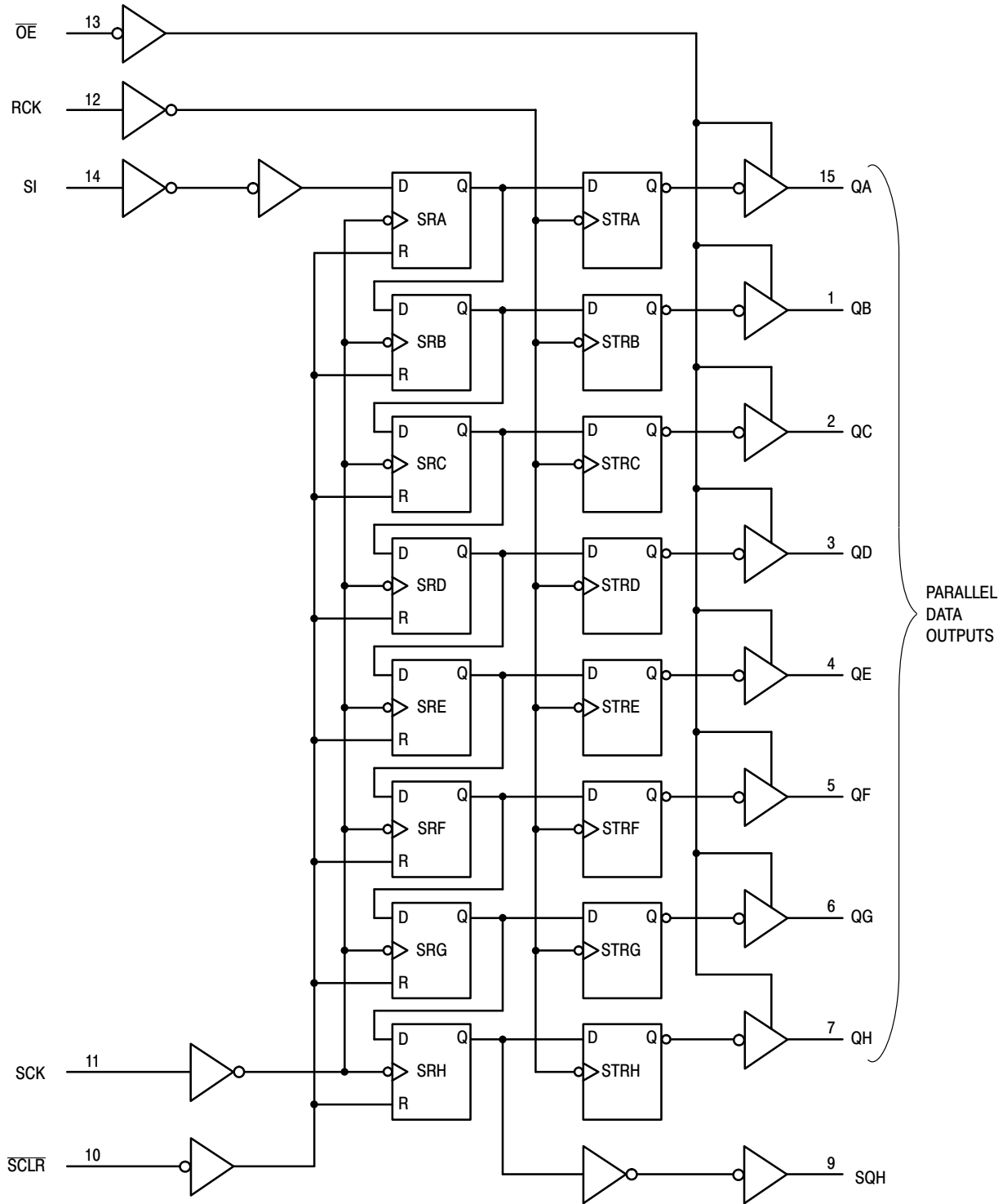
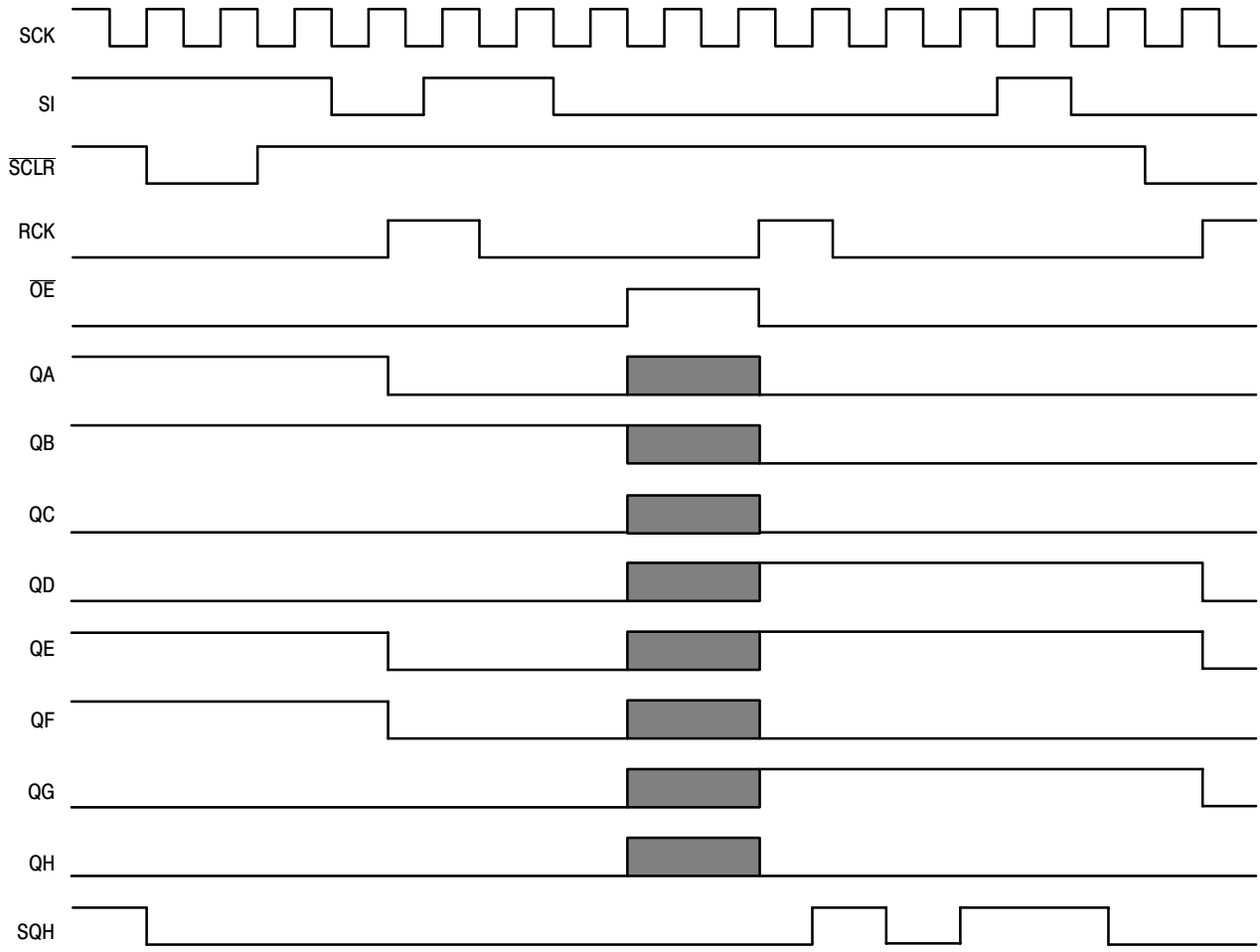



Figure 8.

# MC74VHC595

## TIMING DIAGRAM



NOTE:  output is in a high-impedance state.

## INPUT EQUIVALENT CIRCUIT

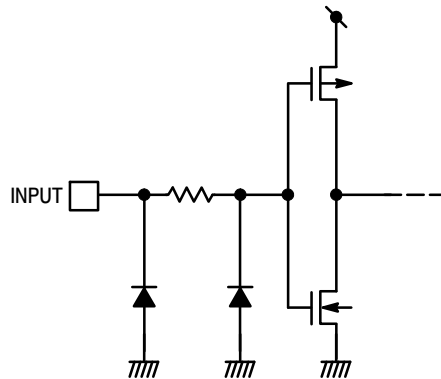

# MC74VHC595

## ORDERING INFORMATION

Device	Marking	Package	Shipping†
MC74VHC595DR2G	VHC595G	SOIC-16	2500 Units / Tape & Reel
MC74VHC595DTR2G	VHC 595	TSSOP-16	2500 Units / Tape & Reel
MC74VHC595DTR2G-Q*	VHC 595	TSSOP-16	2500 Units / Tape & Reel

†For information on tape and reel specifications, including part orientation and tape sizes, please refer to our Tape and Reel Packaging Specifications Brochure, BRD8011/D.

\*-Q Suffix for Automotive and Other Applications Requiring Unique Site and Control Change Requirements; AEC-Q100 Qualified and PPAP Capable.

# MC74VHC595

## PACKAGE DIMENSIONS

QFN16, 2.5x3.5, 0.5P  
CASE 485AW  
ISSUE O

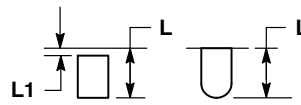
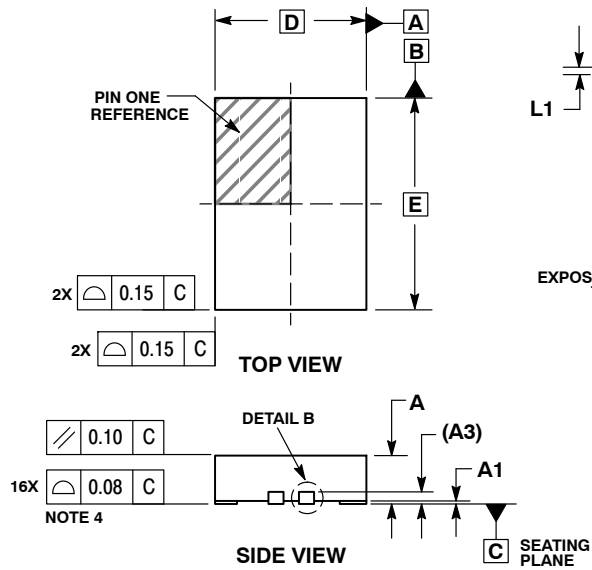

**DETAIL A**  
ALTERNATE TERMINAL  
CONSTRUCTIONS

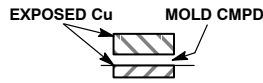

**DETAIL B**  
ALTERNATE  
CONSTRUCTIONS

**NOTES:**

1. DIMENSIONING AND TOLERANCING PER ASME Y14.5M, 1994.
2. CONTROLLING DIMENSION: MILLIMETERS.
3. DIMENSIONS b APPLIES TO PLATED TERMINAL AND IS MEASURED BETWEEN 0.15 AND 0.30 MM FROM TERMINAL.
4. COPLANARITY APPLIES TO THE EXPOSED PAD AS WELL AS THE TERMINALS.

MILLIMETERS		
DIM	MIN	MAX
A	0.80	1.00
A1	0.00	0.05
A3	0.20 REF	
b	0.20	0.30
D	2.50 BSC	
D2	0.85	1.15
E	3.50 BSC	
E2	1.85	2.15
e	0.50 BSC	
K	0.20	---
L	0.35	0.45
L1	---	0.15

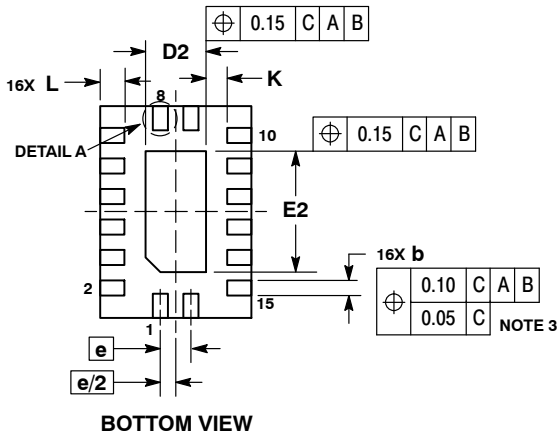

**RECOMMENDED  
SOLDERING FOOTPRINT\***

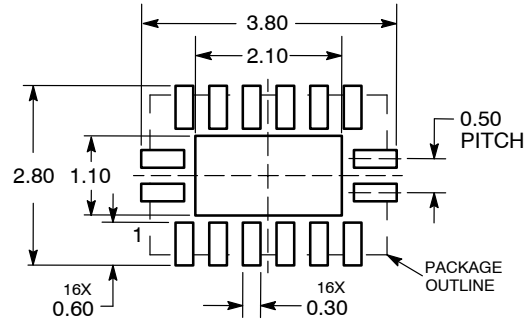

DIMENSIONS: MILLIMETERS

\*For additional information on our Pb-Free strategy and soldering details, please download the **onsemi** Soldering and Mounting Techniques Reference Manual, SOLDERRM/D.

# MC74VHC595

## PACKAGE DIMENSIONS

SOIC-16  
CASE 751B-05  
ISSUE K

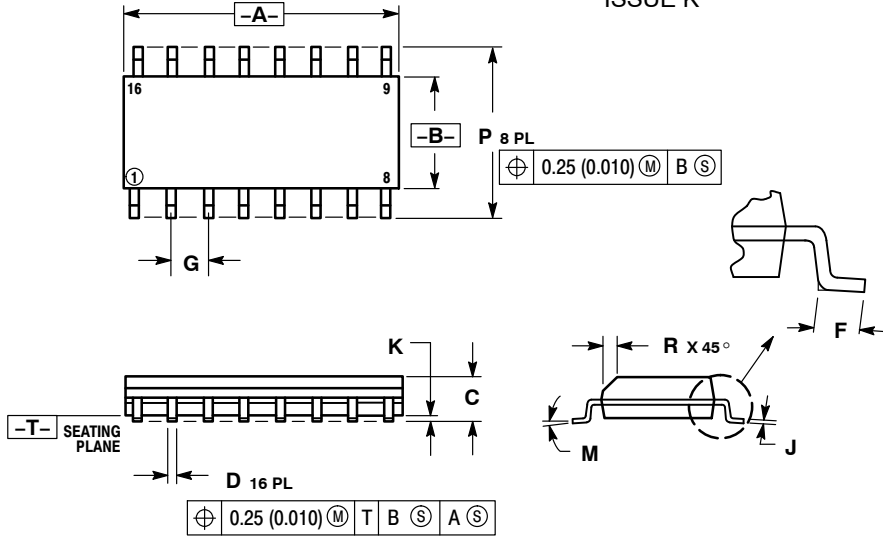

NOTES:

1. DIMENSIONING AND TOLERANCING PER ANSI Y14.5M, 1982.
2. CONTROLLING DIMENSION: MILLIMETER.
3. DIMENSIONS A AND B DO NOT INCLUDE MOLD PROTRUSION.
4. MAXIMUM MOLD PROTRUSION 0.15 (0.006) PER SIDE.
5. DIMENSION D DOES NOT INCLUDE DAMBAR PROTRUSION. ALLOWABLE DAMBAR PROTRUSION SHALL BE 0.127 (0.005) TOTAL IN EXCESS OF THE D DIMENSION AT MAXIMUM MATERIAL CONDITION.

DIM	MILLIMETERS		INCHES	
	MIN	MAX	MIN	MAX
A	9.80	10.00	0.386	0.393
B	3.80	4.00	0.150	0.157
C	1.35	1.75	0.054	0.068
D	0.35	0.49	0.014	0.019
F	0.40	1.25	0.016	0.049
G	1.27 BSC		0.050 BSC	
J	0.19	0.25	0.008	0.009
K	0.10	0.25	0.004	0.009
M	0°	7°	0°	7°
P	5.80	6.20	0.229	0.244
R	0.25	0.50	0.010	0.019

### SOLDERING FOOTPRINT

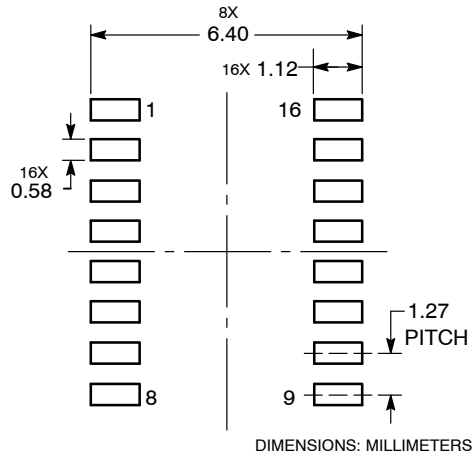

# MC74VHC595

## PACKAGE DIMENSIONS

TSSOP-16  
CASE 948F  
ISSUE B

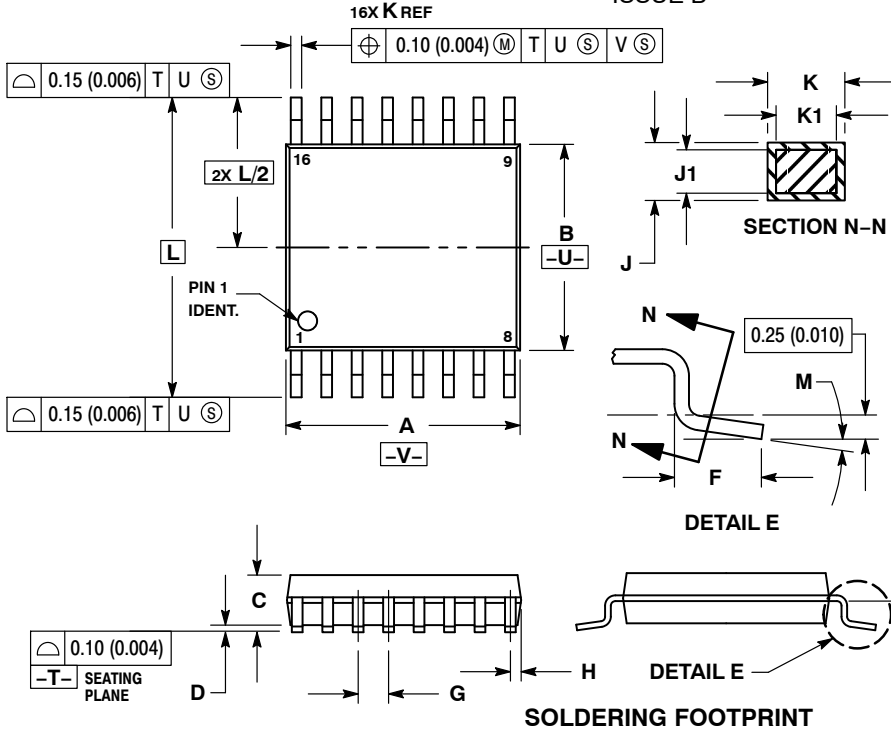

### NOTES:

1. DIMENSIONING AND TOLERANCING PER ANSI Y14.5M, 1982.
2. CONTROLLING DIMENSION: MILLIMETER.
3. DIMENSION A DOES NOT INCLUDE MOLD FLASH. PROTRUSIONS OR GATE BURRS. MOLD FLASH OR GATE BURRS SHALL NOT EXCEED 0.15 (0.006) PER SIDE.
4. DIMENSION B DOES NOT INCLUDE INTERLEAD FLASH OR PROTRUSION. INTERLEAD FLASH OR PROTRUSION SHALL NOT EXCEED 0.25 (0.010) PER SIDE.
5. DIMENSION K DOES NOT INCLUDE DAMBAR PROTRUSION. ALLOWABLE DAMBAR PROTRUSION SHALL BE 0.08 (0.003) TOTAL IN EXCESS OF THE K DIMENSION AT MAXIMUM MATERIAL CONDITION.
6. TERMINAL NUMBERS ARE SHOWN FOR REFERENCE ONLY.
7. DIMENSION A AND B ARE TO BE DETERMINED AT DATUM PLANE -W-.

DIM	MILLIMETERS		INCHES	
	MIN	MAX	MIN	MAX
A	4.90	5.10	0.193	0.200
B	4.30	4.50	0.169	0.177
C	---	1.20	---	0.047
D	0.05	0.15	0.002	0.006
F	0.50	0.75	0.020	0.030
G	0.65 BSC		0.026 BSC	
H	0.18	0.28	0.007	0.011
J	0.09	0.20	0.004	0.008
J1	0.09	0.16	0.004	0.006
K	0.19	0.30	0.007	0.012
K1	0.19	0.25	0.007	0.010
L	6.40 BSC		0.252 BSC	
M	0°	8°	0°	8°

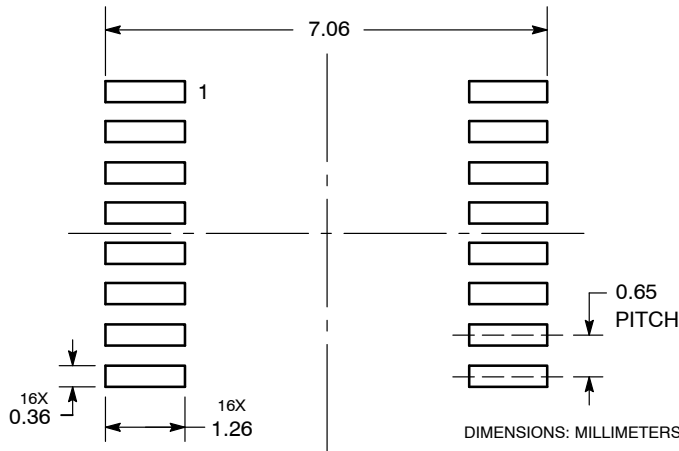

onsemi, Onsemi, and other names, marks, and brands are registered and/or common law trademarks of Semiconductor Components Industries, LLC dba "onsemi" or its affiliates and/or subsidiaries in the United States and/or other countries. onsemi owns the rights to a number of patents, trademarks, copyrights, trade secrets, and other intellectual property. A listing of onsemi's product/patent coverage may be accessed at [www.onsemi.com/site/pdf/Patent-Marking.pdf](http://www.onsemi.com/site/pdf/Patent-Marking.pdf). onsemi reserves the right to make changes at any time to any products or information herein, without notice. The information herein is provided "as-is" and onsemi makes no warranty, representation or guarantee regarding the accuracy of the information, product features, availability, functionality, or suitability of its products for any particular purpose, nor does onsemi assume any liability arising out of the application or use of any product or circuit, and specifically disclaims any and all liability, including without limitation special, consequential or incidental damages. Buyer is responsible for its products and applications using onsemi products, including compliance with all laws, regulations and safety requirements or standards, regardless of any support or applications information provided by onsemi. "Typical" parameters which may be provided in onsemi data sheets and/or specifications can and do vary in different applications and actual performance may vary over time. All operating parameters, including "Typicals" must be validated for each customer application by customer's technical experts. onsemi does not convey any license under any of its intellectual property rights nor the rights of others. onsemi products are not designed, intended, or authorized for use as a critical component in life support systems or any FDA Class 3 medical devices or medical devices with a same or similar classification in a foreign jurisdiction or any devices intended for implantation in the human body. Should Buyer purchase or use onsemi products for any such unintended or unauthorized application, Buyer shall indemnify and hold onsemi and its officers, employees, subsidiaries, affiliates, and distributors harmless against all claims, costs, damages, and expenses, and reasonable attorney fees arising out of, directly or indirectly, any claim of personal injury or death associated with such unintended or unauthorized use, even if such claim alleges that onsemi was negligent regarding the design or manufacture of the part. onsemi is an Equal Opportunity/Affirmative Action Employer. This literature is subject to all applicable copyright laws and is not for resale in any manner.

### ADDITIONAL INFORMATION

#### TECHNICAL PUBLICATIONS:

Technical Library: [www.onsemi.com/design/resources/technical-documentation](http://www.onsemi.com/design/resources/technical-documentation)  
onsemi Website: [www.onsemi.com](http://www.onsemi.com)

#### ONLINE SUPPORT: [www.onsemi.com/support](http://www.onsemi.com/support)

For additional information, please contact your local Sales Representative at [www.onsemi.com/support/sales](http://www.onsemi.com/support/sales)

## Looking for pricing, stock, or lifecycle information?

Click below to explore more details on WIN SOURCE:

 [View NLV74VHC595DTR2G on WIN SOURCE](#)

 [ON Semiconductor](#) Information

## Optimize Your Supply Chain with WIN SOURCE Solutions

-  Global Sourcing Solution
-  Obsolete Management
-  Cost Control Management
-  Shortage Management
-  Alternative Solution
-  Excess Inventory Management