



# Smart Highside High Current Power Switch

## Reversave™

- Reverse battery protection by self turn on of power MOSFET

## Features

- Overload protection
- Current limitation
- Short circuit protection
- Overtemperature protection
- Overvoltage protection (including load dump)
- Clamp of negative voltage at output
- Fast deenergizing of inductive loads <sup>1)</sup>
- Low ohmic inverse current operation
- Diagnostic feedback with load current sense
- Open load detection via current sense
- Loss of  $V_{bb}$  protection<sup>2)</sup>
- **Electrostatic discharge (ESD)** protection
- Green product (RoHS compliant)
- AEC qualified

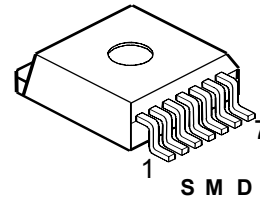
## Application

- Power switch with current sense diagnostic feedback for 12V DC grounded loads
- Most suitable for loads with high inrush current like lamps and motors; all types of resistive and inductive loads
- Replaces electromechanical relays, fuses and discrete circuits

## Product Summary

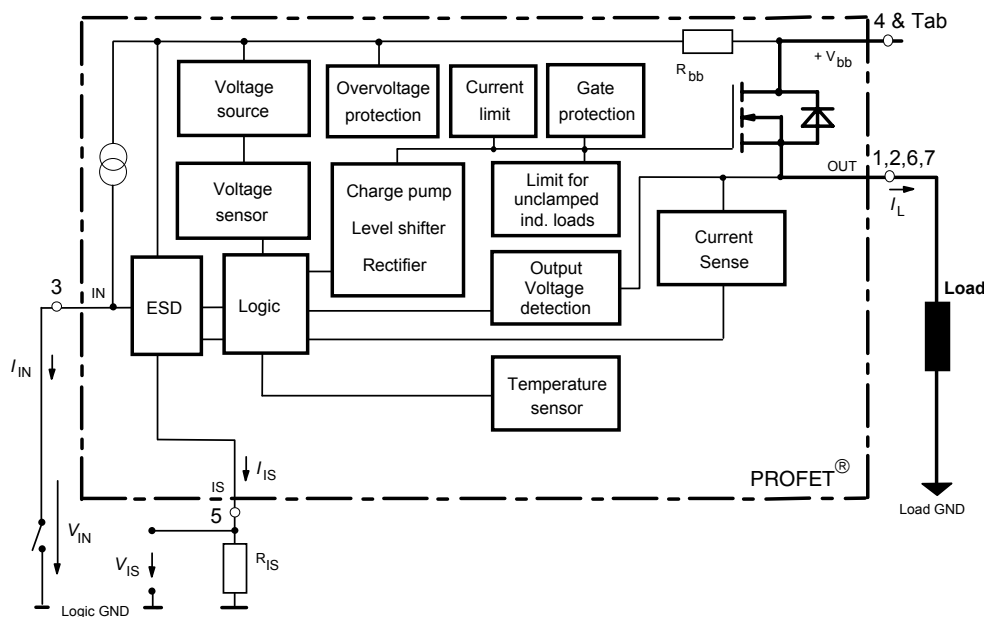
Operating voltage	$V_{bb(on)}$	5.0 ... 34	V
On-state resistance	$R_{ON}$	6.0	mΩ
Noinal current	$I_L(nom)$	17	A
Load current (ISO)	$I_L(ISO)$	70	A
Short circuit current limitation	$I_L(SC)$	130	A
Current sense ratio	$I_L : I_{IS}$	14 000	

PG-TO220-7-4



## General Description

N channel vertical power FET with charge pump, current controlled input and diagnostic feedback with load current sense, integrated in Smart SIPMOS® chip on chip technology. Providing embedded protective functions.



<sup>1)</sup> With additional external diode.

<sup>2)</sup> Additional external diode required for energized inductive loads (see page 8).

Pin	Symbol		Function
1	OUT	O	Output to the load. The pins 1,2,6 and 7 must be shorted with each other especially in high current applications! <sup>3)</sup>
2	OUT	O	Output to the load. The pins 1,2,6 and 7 must be shorted with each other especially in high current applications! <sup>3)</sup>
3	IN	I	Input, activates the power switch in case of short to ground
4	V <sub>bb</sub>	+	Positive power supply voltage, the tab is electrically connected to this pin. In high current applications the tab should be used for the V <sub>bb</sub> connection instead of this pin <sup>4)</sup> .
5	IS	S	Diagnostic feedback providing a sense current proportional to the load current; zero current on failure (see Truth Table on page 6)
6	OUT	O	Output to the load. The pins 1,2,6 and 7 must be shorted with each other especially in high current applications! <sup>3)</sup>
7	OUT	O	Output to the load. The pins 1,2,6 and 7 must be shorted with each other especially in high current applications! <sup>3)</sup>

**Maximum Ratings** at  $T_j = 25\text{ °C}$  unless otherwise specified

Parameter	Symbol	Values	Unit
Supply voltage (overvoltage protection see page 4)	V <sub>bb</sub>	42	V
Supply voltage for short circuit protection, $T_{j,start} = -40 \dots +150\text{ °C}$ : (E <sub>AS</sub> limitation see diagram on page 9)	V <sub>bb</sub>	34	V
Load current (short circuit current, see page 5)	I <sub>L</sub>	self-limited	A
Load dump protection $V_{LoadDump} = V_A + V_S$ , $V_A = 13.5\text{ V}$ $R_I^5) = 2\ \Omega$ , $R_L = 0.54\ \Omega$ , $t_d = 200\text{ ms}$ , IN, IS = open or grounded	V <sub>Load dump</sub> <sup>6)</sup>	75	V
Operating temperature range	T <sub>j</sub>	-40 ... +150	°C
Storage temperature range	T <sub>stg</sub>	-55 ... +150	
Power dissipation (DC), $T_C \leq 25\text{ °C}$	P <sub>tot</sub>	170	W
Inductive load switch-off energy dissipation, single pulse $V_{bb} = 12\text{ V}$ , $T_{j,start} = 150\text{ °C}$ , $T_C = 150\text{ °C}$ const., $I_L = 20\text{ A}$ , $Z_L = 7.5\text{ mH}$ , $0\ \Omega$ , (see diagrams on page 9)	E <sub>AS</sub>	1.5	J
Electrostatic discharge capability (ESD) Human Body Model acc. MIL-STD883D, method 3015.7 and ESD asn. std. S5.1-1993, C = 100 pF, R = 1.5 k $\Omega$	V <sub>ESD</sub>	4	kV
Current through input pin (DC)	I <sub>IN</sub>	+15, -250	mA
Current through current sense status pin (DC) see internal circuit diagrams on page 7	I <sub>IS</sub>	+15, -250	

<sup>3)</sup> Not shorting all outputs will considerably increase the on-state resistance, reduce the peak current capability and decrease the current sense accuracy

<sup>4)</sup> Otherwise add about 0.3 m $\Omega$  to the R<sub>ON</sub> if the pin is used instead of the tab.

<sup>5)</sup> R<sub>I</sub> = internal resistance of the load dump test pulse generator.

<sup>6)</sup> V<sub>Load dump</sub> is setup without the DUT connected to the generator per ISO 7637-1 and DIN 40839.

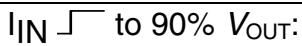
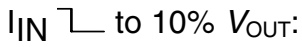
**Thermal Characteristics**

Parameter and Conditions	Symbol	Values			Unit
		min	typ	max	
Thermal resistance chip - case: junction - ambient (free air): SMD version, device on PCB <sup>8)</sup> :	$R_{thJC}^{7)}$	--	--	0.75	K/W
	$R_{thJA}$	--	60	--	
				33	

**Electrical Characteristics**

Parameter and Conditions at $T_j = -40 \dots +150^\circ\text{C}$ , $V_{bb} = 12\text{V}$ unless otherwise specified	Symbol	Values			Unit
		min	typ	max	

**Load Switching Capabilities and Characteristics**

On-state resistance (Tab to pins 1,2,6,7) $V_{IN} = 0$ , $I_L = 20\text{A}$ $T_j = 25^\circ\text{C}$ : $T_j = 150^\circ\text{C}$ :	$R_{ON}$	--	4.4	6.0	m $\Omega$
$V_{IN} = 0$ , $I_L = 90\text{A}$ $V_{bb} = 6\text{V}^{9)}$ , $V_{IN} = 0$ , $I_L = 20\text{A}$ $T_j = 150^\circ\text{C}$ :			7.9	10.5	
			--	10.7	
			--	10	17
Nominal load current <sup>10)</sup> , (Tab to pins 1,2,6,7) ISO Proposal: $V_{ON} = 0.5\text{V}$ , $T_C = 85^\circ\text{C}$ , $T_j \leq 150^\circ\text{C}^{11)}$ SMD <sup>8)</sup> : $T_A = 85^\circ\text{C}$ , $T_j \leq 150^\circ\text{C}$ $V_{ON} \leq 0.5\text{V}$	$I_{L(ISO)}$	55	70	--	A
	$I_{L(NOM)}$	13.6	17	--	
Maximum load current in resistive range (Tab to pins 1,2,6,7) $V_{ON} = 1.8\text{V}$ , $T_C = 25^\circ\text{C}$ : see diagram on page 12 $V_{ON} = 1.8\text{V}$ , $T_C = 150^\circ\text{C}$ :	$I_{L(Max)}$	250	--	--	A
		150	--	--	
Turn-on time <sup>12)</sup> $I_{IN}$  to 90% $V_{OUT}$ :	$t_{on}$	130	230	450	$\mu\text{s}$
Turn-off time $I_{IN}$  to 10% $V_{OUT}$ : $R_L = 1\Omega$ , $T_j = -40\dots+150^\circ\text{C}$	$t_{off}$	90	130	210	
Slew rate on <sup>12)</sup> (10 to 30% $V_{OUT}$ ) $R_L = 1\Omega$ , $T_j = 25^\circ\text{C}$	$dV/dt_{on}$	0.1	0.25	0.6	V/ $\mu\text{s}$
Slew rate off <sup>12)</sup> (70 to 40% $V_{OUT}$ ) $R_L = 1\Omega$ , $T_j = 25^\circ\text{C}$	$-dV/dt_{off}$	0.15	0.35	0.6	V/ $\mu\text{s}$

<sup>7)</sup> Thermal resistance  $R_{thCH}$  case to heatsink (about 0.5 ... 0.9 K/W with silicone paste) not included!

<sup>8)</sup> Device on 50mm\*50mm\*1.5mm epoxy PCB FR4 with 6cm<sup>2</sup> (one layer, 70 $\mu\text{m}$  thick) copper area for  $V_{bb}$  connection. PCB is vertical without blown air.

<sup>9)</sup> Decrease of  $V_{bb}$  below 10 V causes slowly a dynamic increase of  $R_{ON}$  to a higher value of  $R_{ON(Static)}$ . As long as  $V_{bIN} > V_{bIN(u) max}$ ,  $R_{ON}$  increase is less than 10 % per second for  $T_j < 85^\circ\text{C}$ .

<sup>10)</sup> not subject to production test, specified by design

<sup>11)</sup>  $T_j$  is about 105 $^\circ\text{C}$  under these conditions.

<sup>12)</sup> See timing diagram on page 13.

Parameter and Conditions at $T_j = -40 \dots +150^\circ\text{C}$ , $V_{bb} = 12\text{V}$ unless otherwise specified	Symbol	Values			Unit
		min	typ	max	

**Inverse Load Current Operation**

On-state resistance (Pins 1,2,6,7 to pin 4) $V_{bIN} = 12\text{V}$ , $I_L = -20\text{A}$ see page 9	$T_j = 25^\circ\text{C}$ : $T_j = 150^\circ\text{C}$ :	$R_{ON(inv)}$	--	4.4 7.9	6.0 10.5	$\text{m}\Omega$
Nominal inverse load current (Pins 1,2,6,7 to Tab) $V_{ON} = -0.5\text{V}$ , $T_C = 85^\circ\text{C}^{11)}$		$I_{L(inv)}$	55	70	--	A
Drain-source diode voltage ( $V_{out} > V_{bb}$ ) $I_L = -20\text{A}$ , $I_{IN} = 0$ , $T_j = +150^\circ\text{C}$		$-V_{ON}$	--	0.6	--	V

**Operating Parameters**

Operating voltage ( $V_{IN} = 0$ ) <sup>9, 13)</sup>		$V_{bb(on)}$	5.0	--	34	V
Undervoltage shutdown <sup>14)</sup>		$V_{bIN(u)}$	1.5	3.0	4.5	V
Undervoltage start of charge pump see diagram page 14		$V_{bIN(ucp)}$	3.0	4.5	6.0	V
Oversvoltage protection <sup>15)</sup> $I_{bb} = 15\text{mA}$	$T_j = -40^\circ\text{C}$ : $T_j = 25\dots+150^\circ\text{C}$ :	$V_{bIN(z)}$	60 62	-- 66	-- --	V
Standby current $I_{IN} = 0$	$T_j = -40\dots+25^\circ\text{C}$ : $T_j = 150^\circ\text{C}$ :	$I_{bb(off)}$	-- --	15 25	25 50	$\mu\text{A}$

<sup>13)</sup> If the device is turned on before a  $V_{bb}$ -decrease, the operating voltage range is extended down to  $V_{bIN(u)}$ . For all voltages 0 ... 34 V the device is provides embedded protection functions against overtemperature and short circuit.

<sup>14)</sup>  $V_{bIN} = V_{bb} - V_{IN}$  see diagram on page 7. When  $V_{bIN}$  increases from less than  $V_{bIN(u)}$  up to  $V_{bIN(ucp)} = 5\text{V}$  (typ.) the charge pump is not active and  $V_{OUT} \approx V_{bb} - 3\text{V}$ .

<sup>15)</sup> See also  $V_{ON(CL)}$  in circuit diagram on page 8.

Parameter and Conditions at $T_j = -40 \dots +150^\circ\text{C}$ , $V_{bb} = 12\text{V}$ unless otherwise specified	Symbol	Values			Unit
		min	typ	max	
<b>Protection Functions<sup>16)</sup></b>					
Short circuit current limit (Tab to pins 1,2,6,7) <sup>17)</sup> $V_{ON} = 6\text{V}$	$T_c = -40^\circ\text{C}$ : $I_{L(SC)}$	--	110	--	A
	$T_c = 25^\circ\text{C}$ : $I_{L(SC)}$	45	130	180	
	$T_c = +150^\circ\text{C}$ : $I_{L(SC)}$	--	115	--	
Output clamp <sup>18)</sup> (inductive load switch off) see diagram Ind. and overvolt. output clamp page 7	$I_L = 40\text{mA}$ : $-V_{OUT(CL)}$	14	17	20	V
Output clamp (inductive load switch off) at $V_{OUT} = V_{bb} - V_{ON(CL)}$ (e.g. overvoltage), $I_L = 40\text{mA}$	$V_{ON(CL)}$	39	42	47	V
Thermal overload trip temperature	$T_{jt}$	150	--	--	$^\circ\text{C}$
Thermal hysteresis	$\Delta T_{jt}$	--	10	--	K

**Reverse Battery**

Reverse battery voltage <sup>19)</sup>	$-V_{bb}$	--	--	32	V
On-state resistance (Pins 1,2,6,7 to pin 4) $V_{bb} = -12\text{V}$ , $V_{IN} = 0$ , $I_L = -20\text{A}$ , $R_{IS} = 1\text{k}\Omega$	$T_j = 25^\circ\text{C}$ : $R_{ON(rev)}$ $T_j = 150^\circ\text{C}$ :	--	5.4 8.9	7.0 12.3	$\text{m}\Omega$
Integrated resistor in $V_{bb}$ line	$R_{bb}$	--	120	--	$\Omega$

**Diagnostic Characteristics**

Current sense ratio, static on-condition, $k_{ILIS} = I_L : I_{IS}$ , $V_{ON} < 1.5\text{V}^{20)}$ , $V_{IS} < V_{OUT} - 5\text{V}$ , $V_{bIN} > 4.0\text{V}$ see diagram on page 11	$I_L = 90\text{A}$ , $T_j = -40^\circ\text{C}$ : $T_j = 25^\circ\text{C}$ : $T_j = 150^\circ\text{C}$ : $I_L = 20\text{A}$ , $T_j = -40^\circ\text{C}$ : $T_j = 25^\circ\text{C}$ : $T_j = 150^\circ\text{C}$ : $I_L = 10\text{A}$ , $T_j = -40^\circ\text{C}$ : $T_j = 25^\circ\text{C}$ : $T_j = 150^\circ\text{C}$ : $I_L = 4\text{A}$ , $T_j = -40^\circ\text{C}$ : $T_j = 25^\circ\text{C}$ : $T_j = 150^\circ\text{C}$ :	$k_{ILIS}$	12 400 12 000 11 400 12 200 12 000 11 500 11 100 11 500 11 400 10 000 11 000 10 600	14 200 13 700 12 800 14 800 14 100 13 200 15 300 14 500 13 300 17 600 15 600 13 800	16 000 15 400 14 200 17 400 16 200 15 000 19 500 17 500 15 200 28 500 22 000 18 000	
$I_{IS} = 0$ by $I_{IN} = 0$ (e.g. during deenergizing of inductive loads):						

<sup>16)</sup> Integrated protection functions are designed to prevent IC destruction under fault conditions described in the data sheet. Fault conditions are considered as "outside" normal operating range. Protection functions are not designed for continuous repetitive operation.

<sup>17)</sup> Short circuit is a failure mode. The device is not designed to operate continuously into a short circuit. The lifetime will be reduced under such conditions.

<sup>18)</sup> This output clamp can be "switched off" by using an additional diode at the IS-Pin (see page 7). If the diode is used,  $V_{OUT}$  is clamped to  $V_{bb} - V_{ON(CL)}$  at inductive load switch off.

<sup>19)</sup> The reverse load current through the intrinsic drain-source diode has to be limited by the connected load (as it is done with all polarity symmetric loads). Note that under off-conditions ( $I_{IN} = I_{IS} = 0$ ) the power transistor is not activated. This results in raised power dissipation due to the higher voltage drop across the intrinsic drain-source diode. The temperature protection is not active during reverse current operation! Increasing reverse battery voltage capability is simply possible as described on page 8.

<sup>20)</sup> If  $V_{ON}$  is higher, the sense current is no longer proportional to the load current due to sense current saturation, see  $I_{IS,lim}$ .

Parameter and Conditions at $T_j = -40 \dots +150^\circ\text{C}$ , $V_{bb} = 12\text{V}$ unless otherwise specified	Symbol	Values			Unit
		min	typ	max	
Sense current saturation	$I_{S,lim}$	6.5	--	--	mA
Current sense leakage current $I_{IN} = 0$ : $V_{IN} = 0$ , $I_L \leq 0$ :	$I_{S(LL)}$	--	--	0.5	$\mu\text{A}$
	$I_{S(LH)}$	--	2	--	
Current sense overvoltage protection $I_{bb} = 15\text{mA}$ $T_j = -40^\circ\text{C}$ : $T_j = 25\dots+150^\circ\text{C}$ :	$V_{bIS(Z)}$	60	--	--	V
		62	66	--	
Current sense settling time <sup>21)</sup>	$t_{s(IS)}$	--	--	500	$\mu\text{s}$

### Input

Input and operating current (see diagram page 12) IN grounded ( $V_{IN} = 0$ )	$I_{IN(on)}$	--	0.8	1.5	mA
Input current for turn-off <sup>22)</sup>	$I_{IN(off)}$	--	--	80	$\mu\text{A}$

### Truth Table

	Input current level	Output level	Current Sense $I_S$	Remark
Normal operation	L H	L H	0 nominal	$=I_L / k_{IIS}$ , up to $I_S = I_{S,lim}$
Very high load current	H	H	$I_{S,lim}$	up to $V_{ON} = V_{ON(Fold\ back)}$ $I_S$ no longer proportional to $I_L$
Current-limitation	H	H	0	$V_{ON} > V_{ON(Fold\ back)}$
Short circuit to GND	L	L	0	
	H	L	0	
Over-temperature	L	L	0	
	H	L	0	
Short circuit to $V_{bb}$	L	H	0	
	H	H	<nominal <sup>23)</sup>	
Open load	L	Z <sup>24)</sup>	0	
	H	H	0	
Negative output voltage clamp	L	L	0	
Inverse load current	L	H	0	
	H	H	0	

L = "Low" Level

H = "High" Level

Overtemperature reset by cooling:  $T_j < T_{jt}$  (see diagram on page 14)

<sup>21)</sup> not subject to production test, specified by design

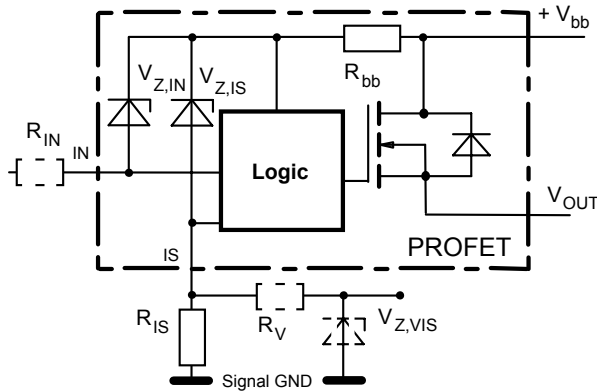
<sup>22)</sup> We recommend the resistance between IN and GND to be less than 0.5 k $\Omega$  for turn-on and more than 500k $\Omega$  for turn-off. Consider that when the device is switched off ( $I_{IN} = 0$ ) the voltage between IN and GND reaches almost  $V_{bb}$ .

<sup>23)</sup> Low ohmic short to  $V_{bb}$  may reduce the output current  $I_L$  and can thus be detected via the sense current  $I_S$ .

<sup>24)</sup> Power Transistor "OFF", potential defined by external impedance.

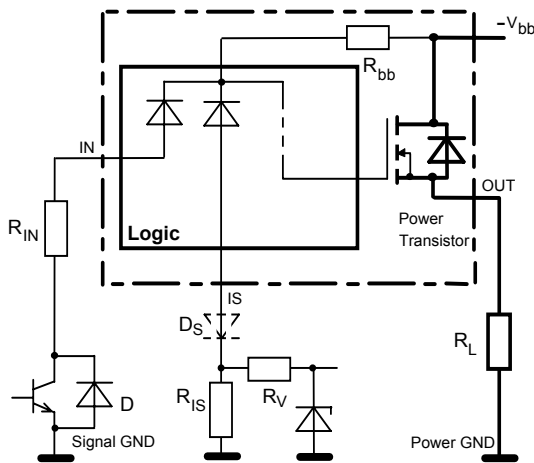


**Overvoltage protection of logic part**



$R_{bb} = 120\Omega$  typ.,  $V_{Z,IN} = V_{Z,IS} = 66V$  typ.,  $R_{IS} = 1k\Omega$  nominal. Note that when overvoltage exceeds 71 V typ. a voltage above 5V can occur between IS and GND, if  $R_V$ ,  $V_{Z,VIS}$  are not used.

**Reverse battery protection**



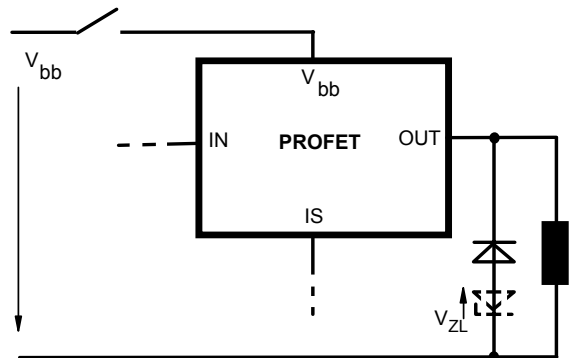
$R_V \geq 1k\Omega$ ,  $R_{IS} = 1k\Omega$  nominal. Add  $R_{IN}$  for reverse battery protection in applications with  $V_{bb}$  above 16 V<sup>19)</sup>; recommended value:  $\frac{1}{R_{IN}} + \frac{1}{R_{IS}} + \frac{1}{R_V} = \frac{0.1A}{|V_{bb}| - 12V}$  if  $D_S$  is not used (or  $\frac{1}{R_{IN}} = \frac{0.1A}{|V_{bb}| - 12V}$  if  $D_S$  is used).

To minimize power dissipation at reverse battery operation, the summarized current into the IN and IS pin should be about 120mA. The current can be provided by using a small signal diode D in parallel to the input switch, by using a MOSFET input switch or by proper adjusting the current through  $R_{IS}$  and  $R_V$ .

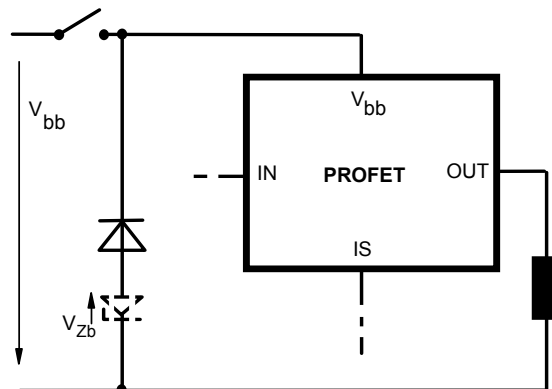
**V<sub>bb</sub> disconnect with energized inductive load**

Provide a current path with load current capability by using a diode, a Z-diode, or a varistor. ( $V_{ZL} < 72V$  or  $V_{Zb} < 30V$  if  $R_{IN}=0$ ). For higher clamp voltages currents at IN and IS have to be limited to 250 mA.

Version a:

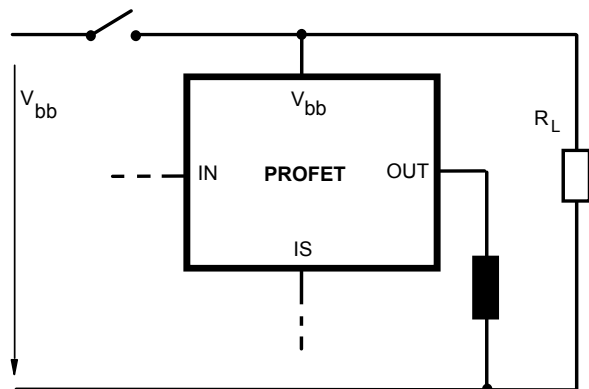


Version b:

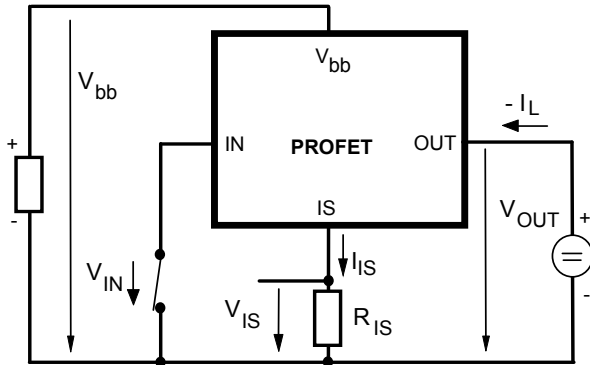


Note that there is no reverse battery protection when using a diode without additional Z-diode  $V_{ZL}$ ,  $V_{Zb}$ .

Version c: Sometimes a necessary voltage clamp is given by non inductive loads  $R_L$  connected to the same switch and eliminates the need of clamping circuit:



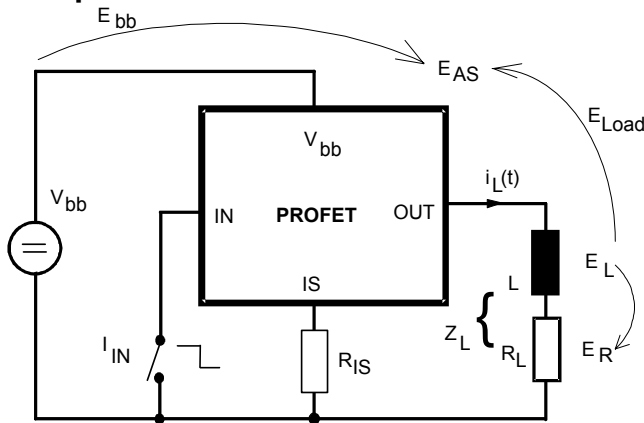
### Inverse load current operation



The device is specified for inverse load current operation ( $V_{OUT} > V_{bb} > 0V$ ). The current sense feature is not available during this kind of operation ( $I_{IS} = 0$ ). With  $I_{IN} = 0$  (e.g. input open) only the intrinsic drain source diode is conducting resulting in considerably increased power dissipation. If the device is switched on ( $V_{IN} = 0$ ), this power dissipation is decreased to the much lower value  $R_{ON(INV)} \cdot I^2$  (specifications see page 4).

Note: Temperature protection during inverse load current operation is not possible!

### Inductive load switch-off energy dissipation



Energy stored in load inductance:

$$E_L = 1/2 \cdot L \cdot I_L^2$$

While demagnetizing load inductance, the energy dissipated in PROFET is

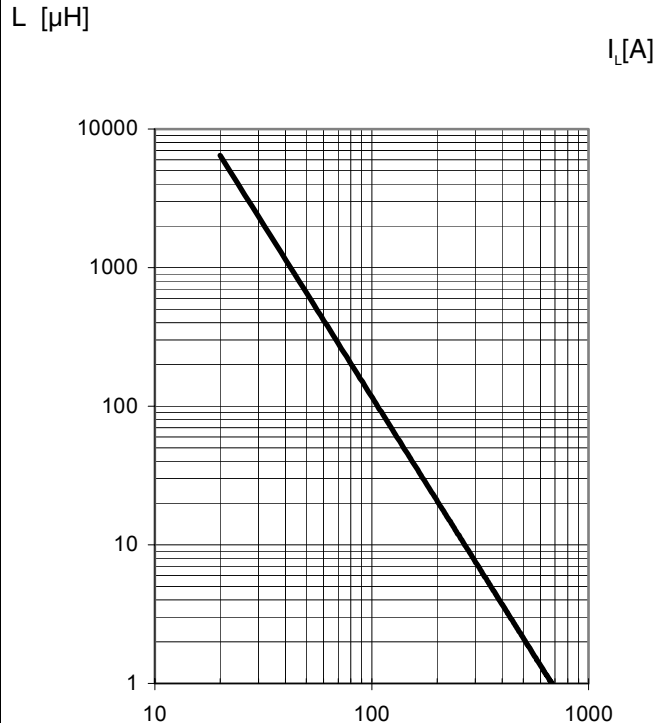
$$E_{AS} = E_{bb} + E_L - E_R = \int V_{ON(CL)} \cdot i_L(t) dt,$$

with an approximate solution for  $R_L > 0 \Omega$ :

$$E_{AS} = \frac{I_L \cdot L}{2 \cdot R_L} (V_{bb} + |V_{OUT(CL)}|) \ln \left( 1 + \frac{I_L \cdot R_L}{|V_{OUT(CL)}|} \right)$$

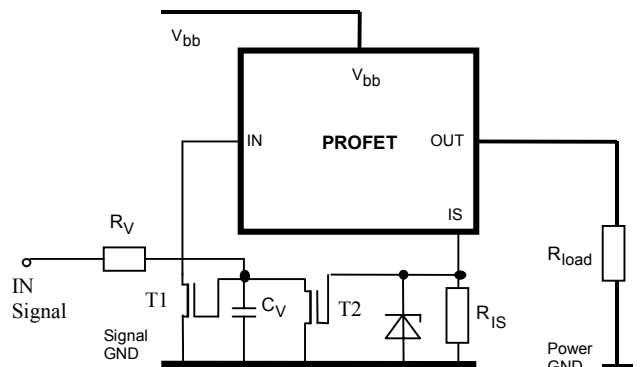
### Maximum allowable load inductance for a single switch off

$L = f(I_L)$ ;  $T_{j,start} = 150^\circ C$ ,  $V_{bb} = 12V$ ,  $R_L = 0 \Omega$



### Externally adjustable current limit

If the device is conducting, the sense current can be used to reduce the short circuit current and allow higher lead inductance (see diagram above). The device will be turned off, if the threshold voltage of T2 is reached by  $I_s \cdot R_{IS}$ . After a delay time defined by  $R_V \cdot C_V$  T1 will be reset. The device is turned on again, the short circuit current is defined by  $I_{L(SC)}$ .



**Options Overview**

Type	BTS50055-1TMC
Overtemperature protection with hysteresis $T_j > 150\text{ °C}$ , latch function <sup>25)</sup>	X
$T_j > 150\text{ °C}$ , with auto-restart on cooling	X
Short circuit to GND protection with overtemperature shutdown switches off when $V_{ON} > 6\text{ V}$ typ. (when first turned on after approx. 180 $\mu\text{s}$ )	X
Overvoltage shutdown	-
Output negative voltage transient limit to $V_{bb} - V_{ON(CL)}$ to $V_{OUT} = -19\text{ V}$ typ	X X <sup>26)</sup>

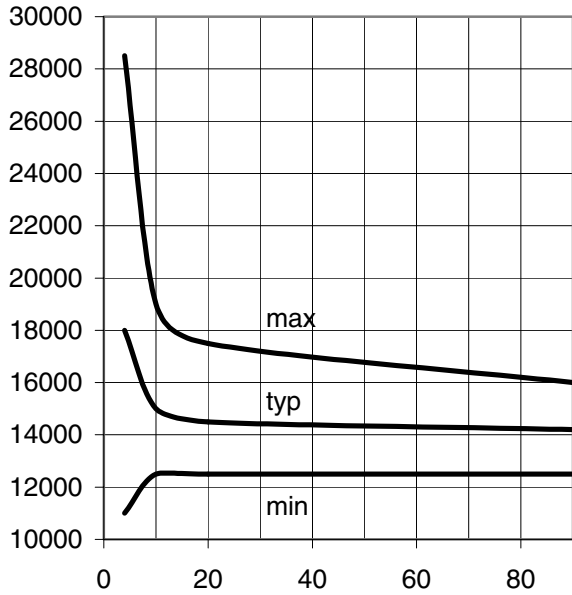
<sup>25)</sup> Latch except when  $V_{bb} - V_{OUT} < V_{ON(SC)}$  after shutdown. In most cases  $V_{OUT} = 0\text{ V}$  after shutdown ( $V_{OUT} \neq 0\text{ V}$  only if forced externally). So the device remains latched unless  $V_{bb} < V_{ON(SC)}$  (see page 5). No latch between turn on and  $t_{d(SC)}$ .

<sup>26)</sup> Can be "switched off" by using a diode  $D_S$  (see page 8) or leaving open the current sense output.

### Characteristics

**Current sense versus load current:**

$I_{IS} = f(I_L), T_J = -40 \dots +150 \text{ }^\circ\text{C}$



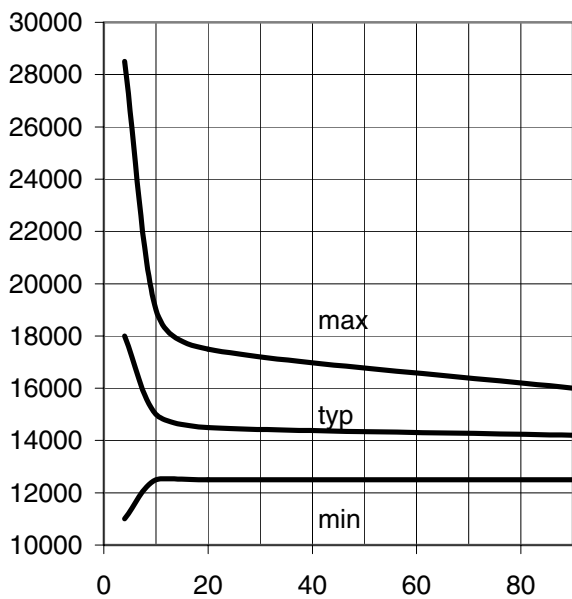
$I_{IS}$  [mA]

$I_L$  [A]

**Current sense ratio:**

$K_{ILIS} = f(I_L), T_J = -40^\circ\text{C}$

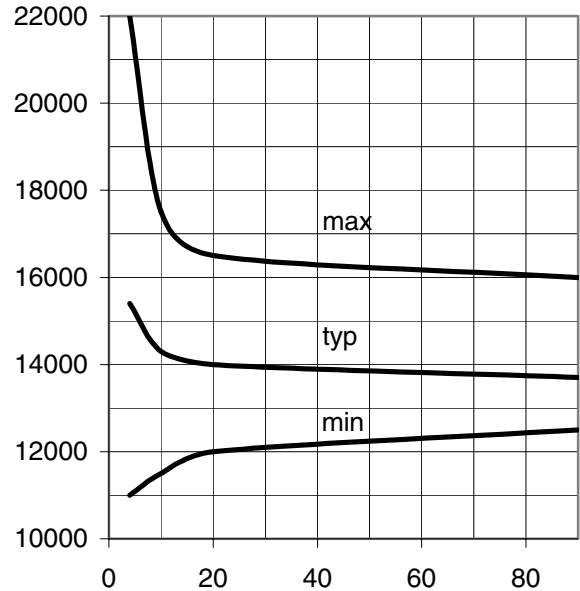
$k_{ILIS}$



$I_L$  [A]

**Current sense ratio:**

$I_{IS} = f(I_L), T_J = 25 \text{ }^\circ\text{C}$



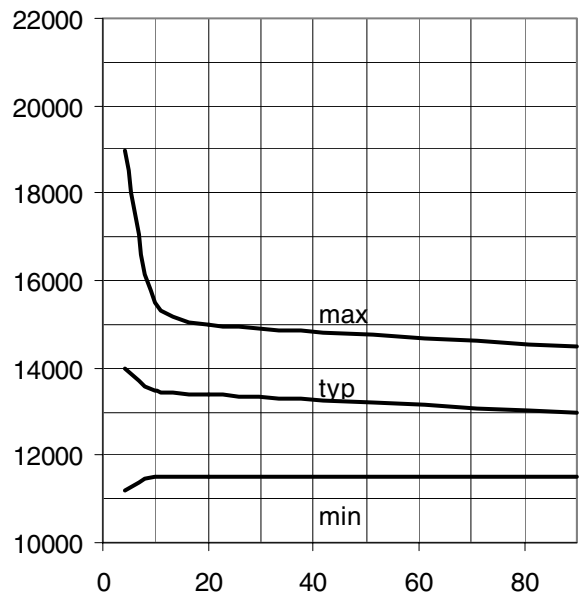
$k_{ILIS}$

$I_L$  [A]

**Current sense ratio:**

$K_{ILIS} = f(I_L), T_J = 150^\circ\text{C}$

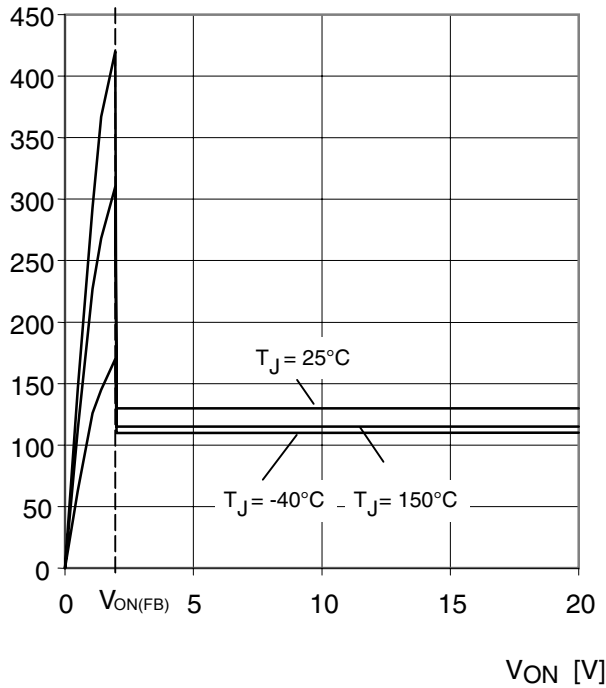
$k_{ILIS}$



$I_L$  [A]

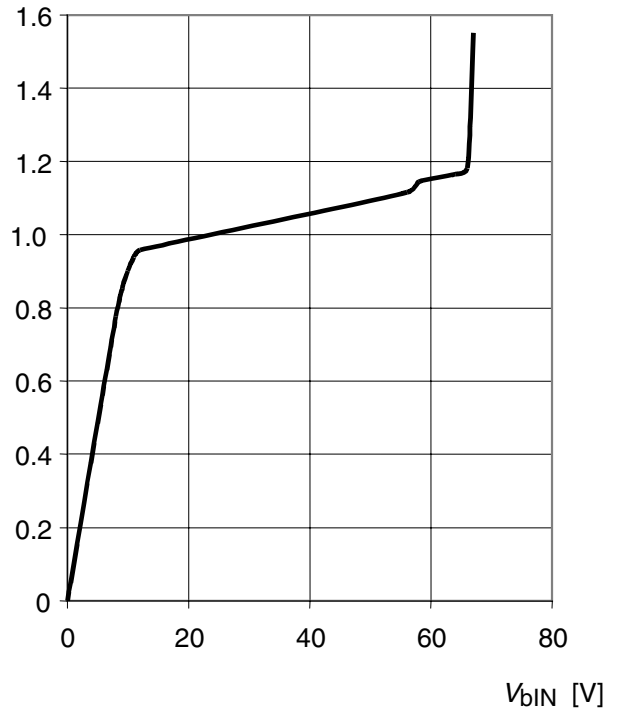
**Typ. current limitation characteristic**  
 $I_L = f(V_{ON}, T_j)$

$I_L$  [A]



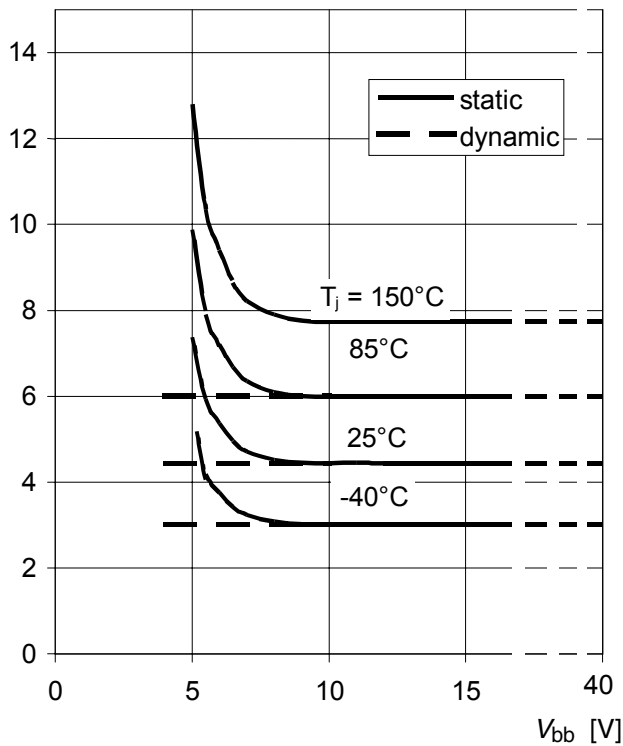
**Typ. input current**

$I_{IN} = f(V_{bIN}), V_{bIN} = V_{bb} - V_{IN}$   
 $I_{IN}$  [mA]



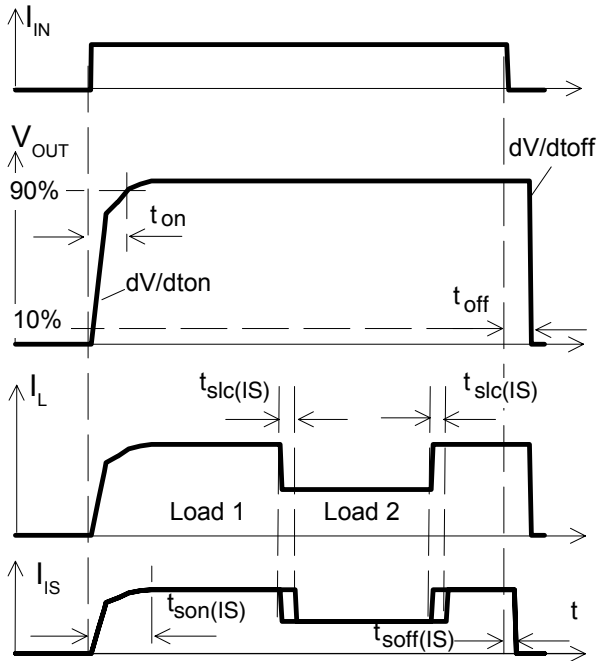
**Typ. on-state resistance**  
 $R_{ON} = f(V_{bb}, T_j); I_L = 20\text{ A}; V_{IN} = 0$

$R_{ON}$  [mOhm]



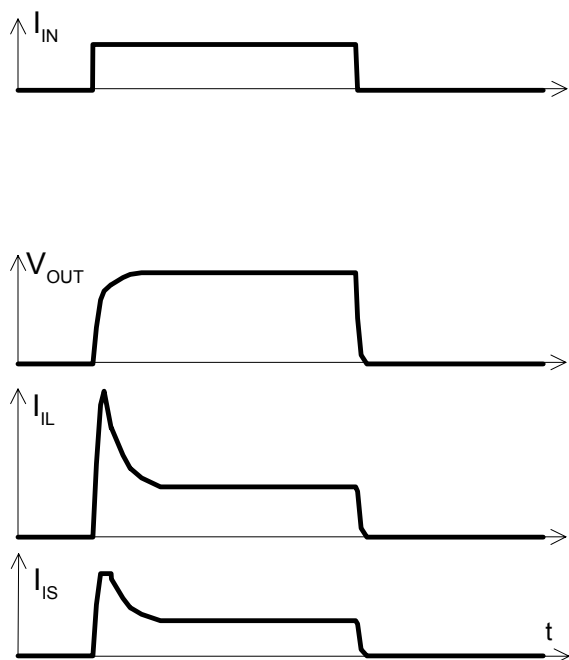
## Timing diagrams

**Figure 1a:** Switching a resistive load, change of load current in on-condition:



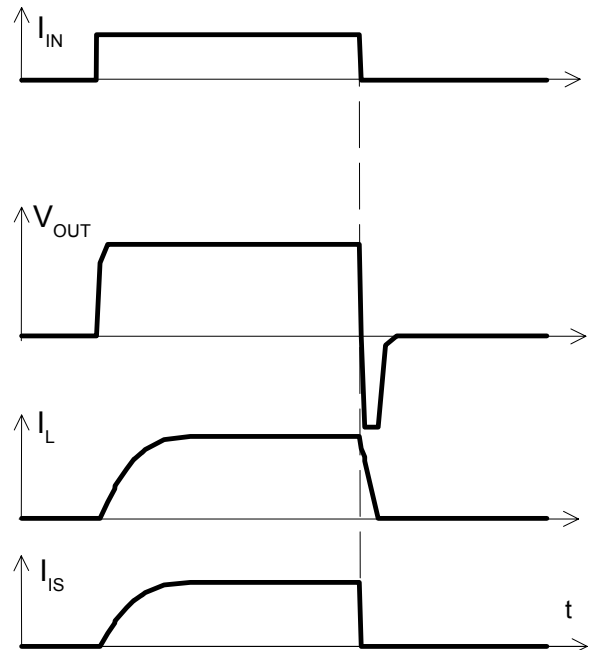
The sense signal is not valid during a settling time after turn-on/off and after change of load current.

**Figure 2b:** Switching motors and lamps:



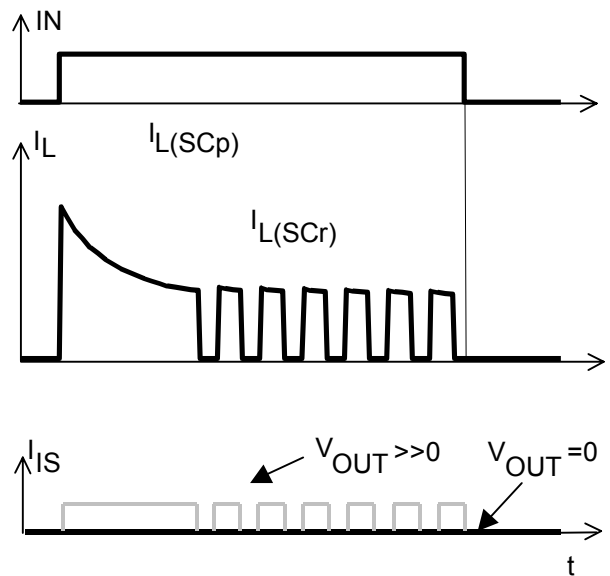
Sense current saturation can occur at very high inrush currents (see  $I_{IS,lim}$  on page 6).

**Figure 2c:** Switching an inductive load:

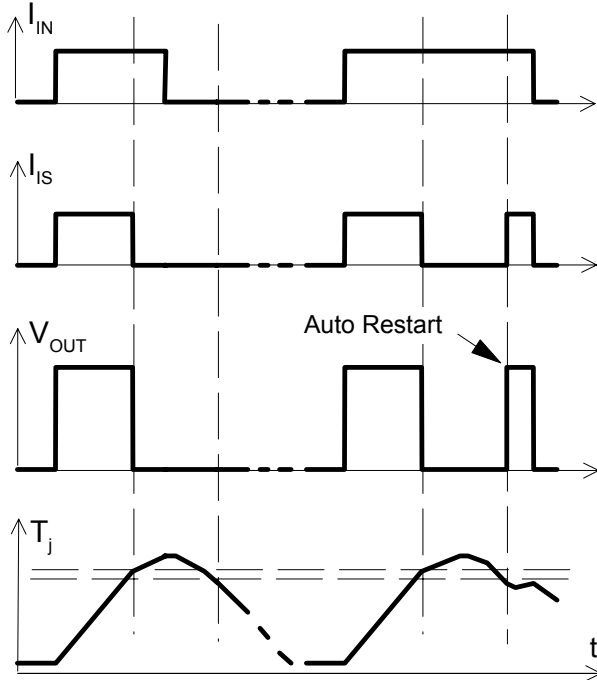


**Figure 3d:** Short circuit:

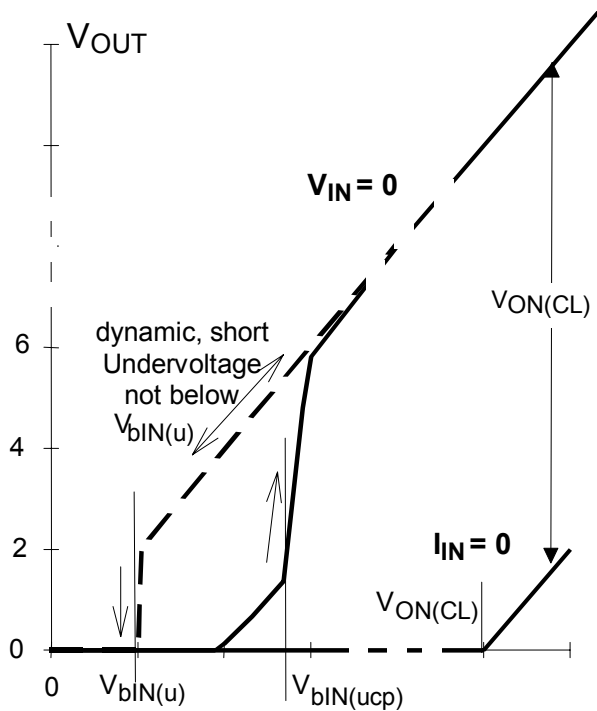
shut down by overtemperature detection with auto restart on cooling



**Figure 4e:** Overtemperature Reset if  $T_j < T_{jt}$



**Figure 6f:** Undervoltage restart of charge pump, overvoltage clamp

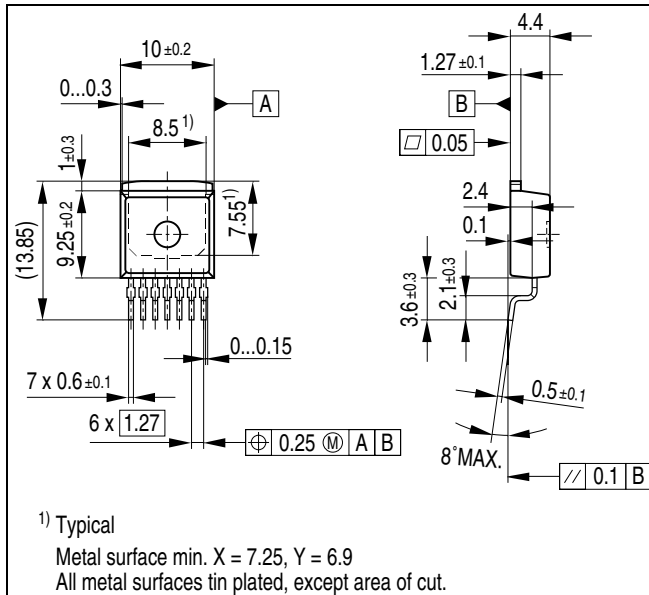


## Package and Ordering Code

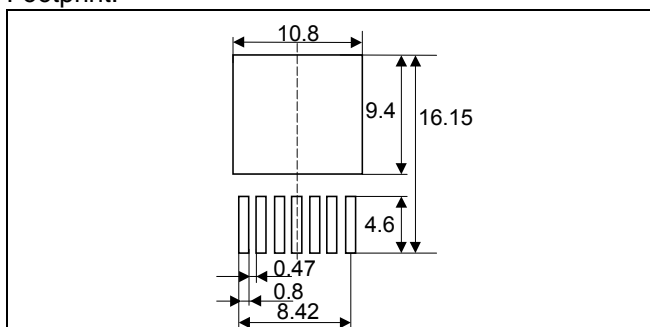
All dimensions in mm

### SMD: PG-TO220-7-4

Sales Code	BTS50055-1TMC
------------	---------------



Footprint:



### Green Product (RoHS compliant)

To meet the world-wide customer requirements for environmentally friendly products and to be compliant with government regulations the device is available as a green product. Green products are RoHS-Compliant (i.e Pb-free finish on leads and suitable for Pb-free soldering according to IPC/JEDEC J-STD-020).

## Revision History

Version	Date	Changes
Rev. 1.1	2010-04-27	Limits of parameter $t_{on}$ changed to min 130 $\mu$ s / max 450 $\mu$ s Limits of parameter $t_{off}$ changed to min 90 $\mu$ s / max 210 $\mu$ s
Rev. 1.0	2008-01-24	Initial version of data sheet. Green (RoHS compliant) variant of BTS6510B

**Edition 2010-April-27**

**Published by  
Infineon Technologies AG  
81726 Munich, Germany**

**© Infineon Technologies AG 2010.  
All Rights Reserved.**

#### **Legal Disclaimer**

The information given in this document shall in no event be regarded as a guarantee of conditions or characteristics ("Beschaffenhheitsgarantie"). With respect to any examples or hints given herein, any typical values stated herein and/or any information regarding the application of the device, Infineon Technologies hereby disclaims any and all warranties and liabilities of any kind, including without limitation warranties of non-infringement of intellectual property rights of any third party.

#### **Information**

For further information on technology, delivery terms and conditions and prices please contact your nearest Infineon Technologies Office ([www.infineon.com](http://www.infineon.com)).

#### **Warnings**

Due to technical requirements components may contain dangerous substances. For information on the types in question please contact your nearest Infineon Technologies Office.

Infineon Technologies Components may only be used in life-support devices or systems with the express written approval of Infineon Technologies, if a failure of such components can reasonably be expected to cause the failure of that life-support device or system, or to affect the safety or effectiveness of that device or system. Life support devices or systems are intended to be implanted in the human body, or to support and/or maintain and sustain and/or protect human life. If they fail, it is reasonable to assume that the health of the user or other persons may be endangered.

## Looking for pricing, stock, or lifecycle information?

Click below to explore more details on WIN SOURCE:

-  [View BTS50055-1TMC](#) on WIN SOURCE
-  [Infineon Technologies](#) Information

## Optimize Your Supply Chain with WIN SOURCE Solutions

-  Global Sourcing Solution
-  Obsolete Management
-  Cost Control Management
-  Shortage Management
-  Alternative Solution
-  Excess Inventory Management