



**THE DATASHEET OF
BU97540KV-ME2**



LCD Segment Drivers

Multi-function Segment Drivers

BU97540KV-M MAX335 Segment(67segx5COM)

General Description

The BU97540KV-M is 1/5, 1/4, 1/3duty or Static General-purpose LCD driver. The BU97540KV-M can drive up to 335 LCD Segments. The BU97540KV-M can also control up to 9 General-purpose/PWM output pins.

These products also incorporate a key scan circuit that accepts input from up to 30 keys to reduce printed circuit board wiring.

Features

- AEC-Q100 Qualified *(Note)*
- Key input function for up to 30 keys (A key scan is performed only when a key is pressed.)
- Supports 1 chip(Master) mode and 2 chip(Master + Slave) mode
- Either 1/5, 1/4, 1/3 or Static can be selected with the serial control data.
 1 chip mode(only Master):
 1/5 duty drive: Up to 335 segments can be driven
 1/4 duty drive: Up to 272 segments can be driven
 1/3 duty drive: Up to 204 segments can be driven
 Static drive: Up to 68 segments can be driven
 2 chip mode(Master + Slave):
 1/5 duty drive: Up to 680 segments can be driven
 1/4 duty drive: Up to 548 segments can be driven
 1/3 duty drive: Up to 411 segments can be driven
 Static drive: Up to 137 segments can be driven
- Serial data control of frame frequency for common and segment output waveforms.
- Serial data control of switching between the segment output pin, PWM output pin and General-purpose output pin functions.(Max 9 pins)
- Built-in OSC circuit
- Integrated Voltage Detected Type Power on Reset (VDET) circuit
- No external component
- Low power consumption design
- Supports Line and Frame Inversion

(Note) Grade 3

Applications

- Car audio, Home electrical appliance, Meter equipment etc.

Key Specifications

- | | |
|--------------------------------|----------------------------------|
| ■ Supply Voltage Range: | +2.7V to +6.0V |
| ■ Operating Temperature Range: | -40°C to +85°C |
| ■ Max Segments: | 335 Segments |
| ■ Display Duty: | Static, 1/3, 1/4, 1/5 Selectable |
| ■ Bias: | 1/2, 1/3, 1/4 Selectable |
| ■ Interface: | 3Wire Serial Interface |

Packages

VQFP80

W(Typ) x D(Typ) x H(Max)

VQFP80

14.00mm x 14.00mm x 1.60mm

Typical Application Circuit

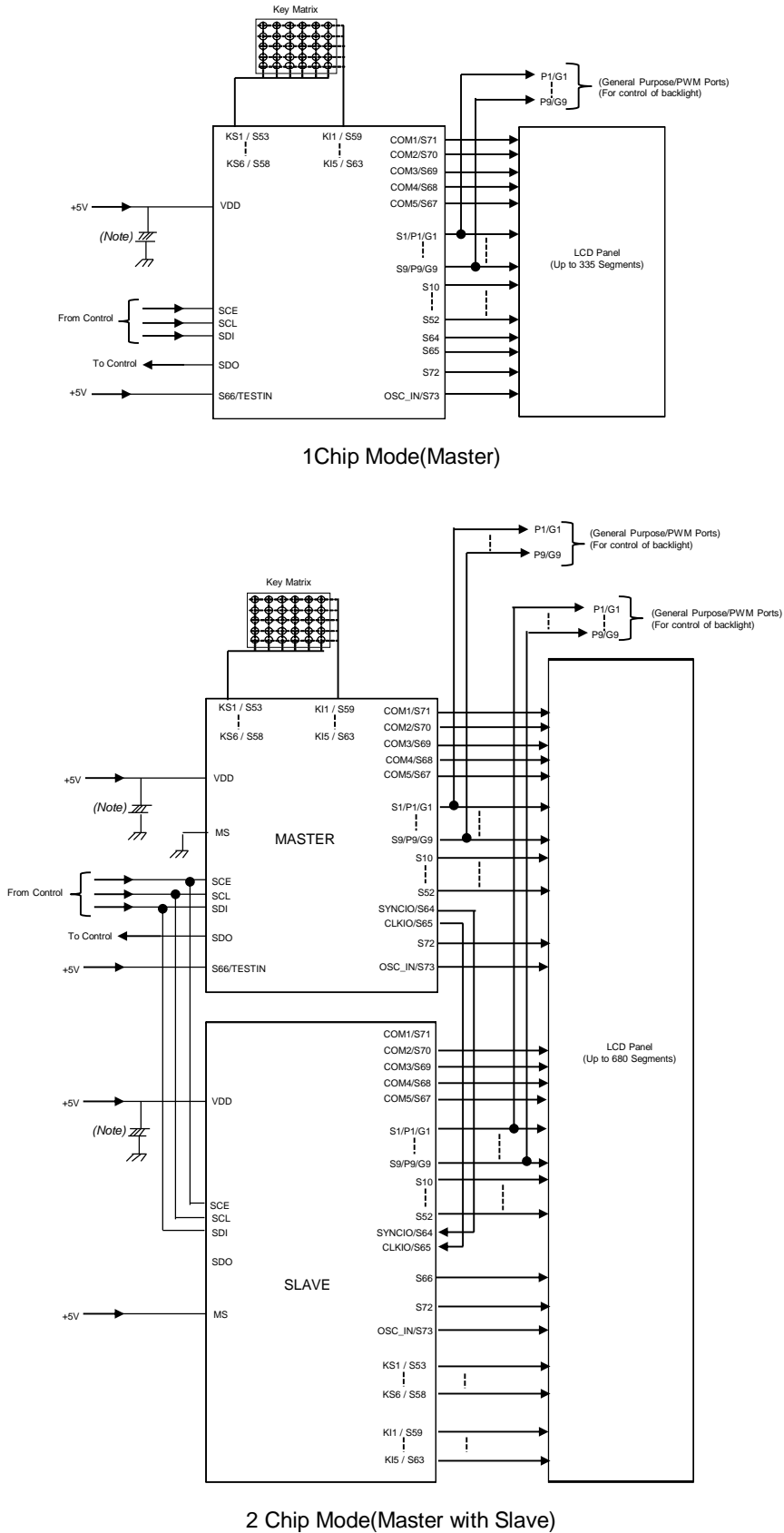

(Note) Insert capacitors between VDD and VSS C≥0.1μF

Figure 1. Typical Application Circuit

Absolute Maximum Ratings (VSS = 0.0V)

Parameter	Symbol	Conditions	Rating	Unit
Maximum Supply Voltage	VDD max	VDD	-0.3 to +7.0	V
Input Voltage	V _{IN1}	SCE, SCL, SDI	-0.3 to +7.0	V
	V _{IN2}	KI1 to KI5	-0.3 to +7.0	V
Allowable Loss	Pd		1.20 ^(Note)	W
Storage Temperature	Tstg		-55 to +125	°C

(Note) When use more than Ta = 25°C, subtract 12mW per degree. (Using ROHM standard board)

(Board size: 70mm×70mm×1.6mm material: FR4 board copper foil: land pattern only)

Caution 1: Operating the IC over the absolute maximum ratings may damage the IC. The damage can either be a short circuit between pins or an open circuit between pins and the internal circuitry. Therefore, it is important to consider circuit protection measures, such as adding a fuse, in case the IC is operated over the absolute maximum ratings.

Caution 2: Should by any chance the maximum junction temperature rating be exceeded the rise in temperature of the chip may result in deterioration of the properties of the chip. In case of exceeding this absolute maximum rating, design a PCB with power dissipation taken into consideration by increasing board size and copper area so as not to exceed the maximum junction temperature rating.

Recommend Operating Conditions (Ta = -40°C to +85°C, VSS = 0.0V)

Parameter	Symbol	Conditions	Rating			Unit
			Min	Typ	Max	
Operating Temperature	Topr		-40	-	+85	°C
Supply Voltage	VDD		2.7	5.0	6.0	V

Electrical Characteristics for the Allowable Operating Ranges

Parameter	Symbol	Pin	Conditions	Limit			Unit
				Min	Typ	Max	
Hysteresis	V _{H1}	SCE, SCL, SDI		-	0.03VDD	-	V
	V _{H2}	KI1 to KI5		-	0.1VDD	-	V
Power-on Detection Voltage	V _{DET}	VDD		1.3	1.8	2.2	V
“H” Level Input Voltage	V _{IH1}	SCE,SCL,SDI, SYNCIO,CLKIO	4.5V ≤ VDD ≤ 6.0V	0.4VDD	-	VDD	V
	V _{IH2}	SCE, SCL, SDI, SYNCIO,CLKIO	2.7V ≤ VDD < 4.5V	0.8VDD	-	VDD	V
	V _{IH3}	KI1 to KI5		0.7VDD	-	VDD	V
“L” Level Input Voltage	V _{IL1}	SCE, SCL, SDI KI1 to KI5 SYNCIO,CLKIO		0	-	0.2VDD	V
Input Floating Voltage	V _{IF}	KI1 to KI5		-	-	0.05VDD	V
Pull-down Resistance	R _{PD}	KI1 to KI5	VDD = 5.0V	50	100	250	kΩ
Output Off Leakage Current	I _{OFFH}	SDO	V _O = 6.0V	-	-	6.0	μA
“H” Level Input Current	I _{IH1}	SCE, SCL, SDI SYNCIO,CLKIO	V _I = 5.5V	-	-	5.0	μA
“L” Level Input Current	I _{IL1}	SCE, SCL, SDI SYNCIO,CLKIO	V _I = 0V	-5.0	-	-	μA
“H” Level Output Voltage	V _{OH1}	S1 to S73	I _O = -20μA, VLCD=1.00*VDD	VDD-0.9	-	-	V
	V _{OH2}	COM1 to COM5	I _O = -100μA, VLCD=1.00*VDD	VDD-0.9	-	-	
	V _{OH3}	P1/G1 to P9/G9	I _O = -1mA	VDD-0.9	-	-	
	V _{OH4}	KS1 to KS6	I _O = -500μA	VDD-1.0	VDD-0.5	VDD-0.2	
	V _{OH5}	SYNCIO,CLKIO	I _O = -1mA	VDD-0.9	-	-	
“L” Level Output Voltage	V _{OL1}	S1 to S70	I _O = 20μA	-	-	0.9	V
	V _{OL2}	COM1 to COM5	I _O = 100μA	-	-	0.9	
	V _{OL3}	P1/G1 to P9/G9	I _O = 1mA	-	-	0.9	
	V _{OL4}	KS1 to KS6	I _O = 25μA	0.2	0.5	1.5	
	V _{OL5}	SDO	I _O = 1mA	-	0.1	0.5	
	V _{OL6}	SYNCIO,CLKIO	I _O = 1mA	-	-	0.9	
Middle Level Output Voltage	V _{MID1}	S1 to S73	1/2 bias I _O = ±20μA VLCD=1.00*VDD	1/2VDD -0.9	-	1/2VDD +0.9	V
	V _{MID2}	COM1 to COM5	1/2 bias I _O = ±100μA VLCD=1.00*VDD	1/2VDD -0.9	-	1/2VDD +0.9	
	V _{MID3}	S1 to S73	1/3 bias I _O = ±20μA VLCD = 1.00*VDD	2/3VDD -0.9	-	2/3VDD +0.9	
	V _{MID4}	S1 to S73	1/3 bias I _O = ±20μA VLCD = 1.00*VDD	1/3VDD -0.9	-	1/3VDD +0.9	
	V _{MID5}	COM1 to COM5	1/3 bias I _O = ±100μA VLCD = 1.00*VDD	2/3VDD -0.9	-	2/3VDD +0.9	
	V _{MID6}	COM1 to COM5	1/3 bias I _O = ±100μA VLCD=1.00*VDD	1/3VDD -0.9	-	1/3VDD +0.9	

Electrical Characteristics – continued

Parameter	Symbol	Pin	Conditions	Limit			Unit
				Min	Typ	Max	
Current Consumption	I _{DD1}	VDD	Power-saving mode	-	-	15	μA
	I _{DD2}	VDD	1chip mode VDD = 5.0V Output open, 1/2 bias Frame frequency = 80Hz VLCD = 1.00*VDD	-	105	220	
	I _{DD3}	VDD	1chip mode VDD = 5.0V Output open, 1/3 bias Frame frequency = 80Hz VLCD = 1.00*VDD	-	130	270	
	I _{DD4}	VDD	2chip mode : Master VDD = 5.0V Output open, 1/3 bias Frame frequency = 80Hz VLCD = 1.00*VDD	-	195	370	
	I _{DD5}	VDD	2chip mode : Slave VDD = 5.0V Output open, 1/3 bias Frame frequency = 80Hz VLCD = 1.00*VDD	-	105	220	

Oscillation Characteristics (Ta = -40 to +85°C, VDD = 2.7V to 6.0V, VSS = 0.0V)

Parameter	Symbol	Pin	Conditions	Limit			Unit
				Min	Typ	Max	
Oscillator Frequency 1	f _{OSC1}	-	VDD = 2.7V to 6.0V	300	-	720	kHz
Oscillator Frequency 2	f _{OSC2}	-	VDD = 5.0V	540	600	660	kHz
Oscillator Frequency 3	f _{OSC3}	-	VDD = 6.0V	562	625	688	kHz
External Clock Frequency ^(Note)	f _{OSC4}	OSC_IN/S73	External clock mode (OC = 1)	30	-	1000	kHz
External Clock Rise Time	t _r			-	160	-	ns
External Clock Fall Time	t _f			-	160	-	ns
External Clock Duty	t _{DTY}			30	50	70	%

(Note) Frame frequency is decided external frequency and dividing ratio of FC0 to FC3 setting.

[Reference Data]

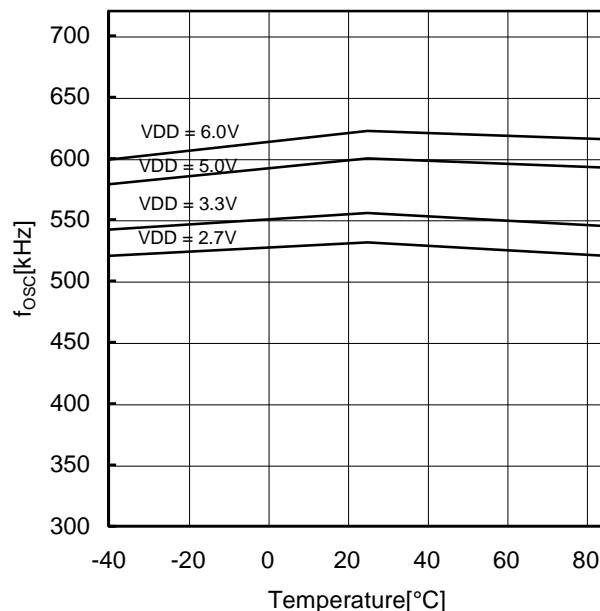

Figure 4. Oscillator Frequency Typical Temperature Characteristics

MPU Interface Characteristics (Ta=-40 to +85°C, VDD = 2.7V to 6.0V, VSS = 0V)

Parameter	Symbol	Pin	Conditions	Limit			Unit
				Min	Typ	Max	
Data Setup Time	t_{DS}	SCL, SDI		120	-	-	ns
Data Hold Time	t_{DH}	SCL, SDI		120	-	-	ns
SCE Wait Time	t_{CP}	SCE, SCL		120	-	-	ns
SCE Setup Time	t_{CS}	SCE, SCL		120	-	-	ns
SCE Hold Time	t_{CH}	SCE, SCL		120	-	-	ns
Clock Cycle Time	t_{CCYC}	SCL		320	-	-	ns
High-level Clock Pulse Width	t_{CHW}	SCL		120	-	-	ns
Low-level Clock Pulse Width (Write)	t_{CLWW}	SCL		120	-	-	ns
Low-level Clock Pulse Width (Read)	t_{CLWR}	SCL	$R_{PU} = 4.7k\Omega$ $C_L = 10pF$ (Note)	1.6	-	-	μs
Rise Time	t_r	SCE, SCL, SDI		-	160	-	ns
Fall Time	t_f	SCE, SCL, SDI		-	160	-	ns
SDO Output Delay Time	t_{DC}	SDO	$R_{PU} = 4.7k\Omega$ $C_L = 10pF$ (Note)	-	-	1.5	μs
SDO Rise Time	t_{DR}	SDO	$R_{PU} = 4.7k\Omega$ $C_L = 10pF$ (Note)	-	-	1.5	μs

(Note) Since SDO is an open-drain output, "t_{DC}" and "t_{DR}" depend on the resistance of the pull-up resistor R_{PU} and the load capacitance C_L.

R_{PU}: 1kΩ ≤ R_{PU} ≤ 10kΩ is recommended.

C_L: A parasitic capacitance to VSS in an application circuit. Any component is not necessary to be attached.

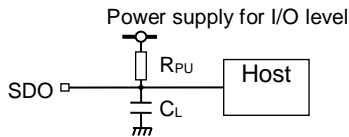

1. When SCL is stopped at the low level

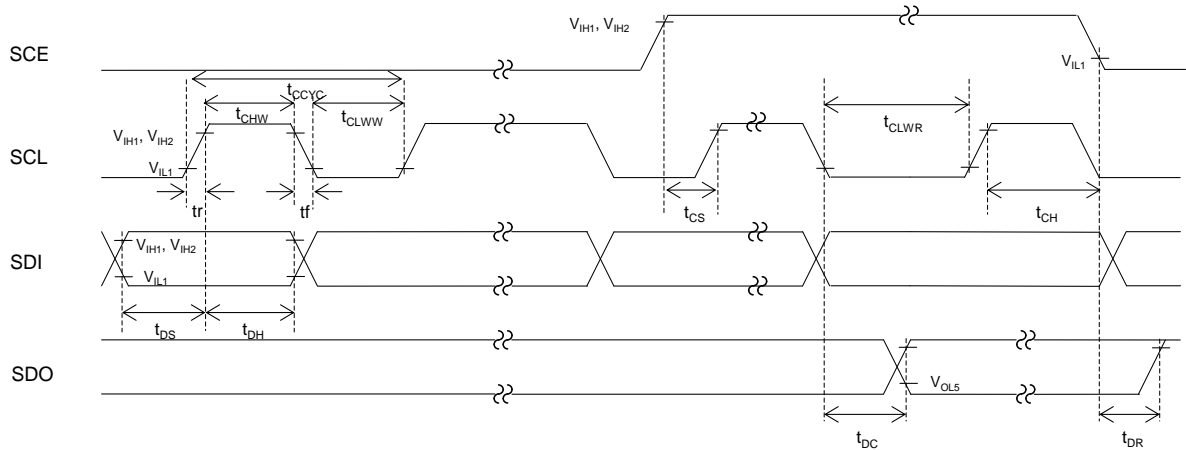

2. When SCL is stopped at the high level

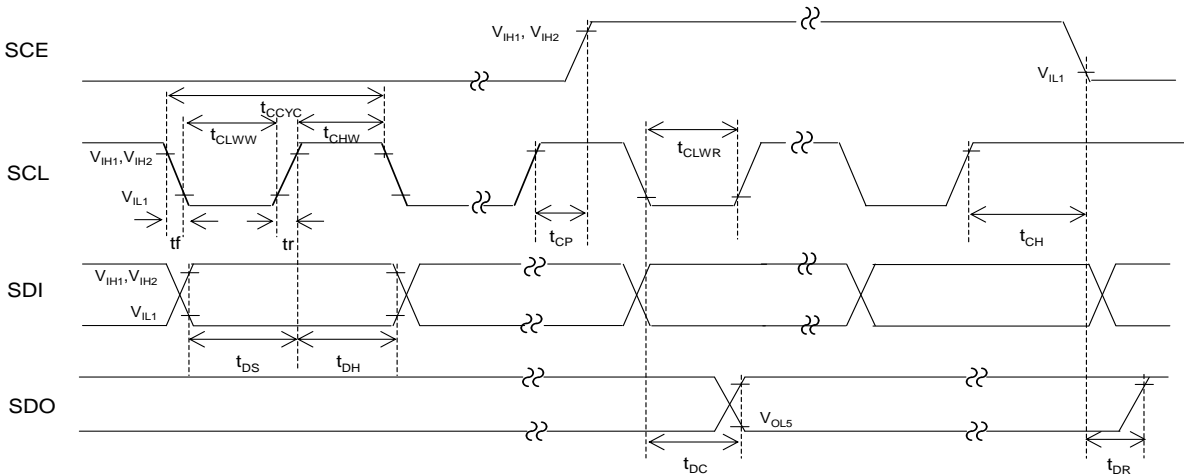



Figure 5. Serial Interface Timing

Pin Description

Symbol	Pin No.	Function	Active	I/O	Handling when unused
S1/P1/G1 to S9/P9/G9	79,80, 1 to 7	Segment output for displaying the display data transferred by serial data input. The S1/P1/G1 to S6/P6/G6 pins can also be used as General-purpose outputs when so set up by the control data.	-	O	OPEN
S10 to S52, S72	8 to 50, 74	Segment output for displaying the display data transferred by serial data input.	-	O	OPEN
KS1/S53 to KS6/S58	51 to 56	Key scan outputs Although normal key scan timing lines require diodes to be inserted in the timing lines to prevent shorts, since these outputs are unbalanced CMOS transistor outputs, these outputs will not be damaged by shorting when these outputs are used to form a key matrix. The KS1/S53 to KS6/S58 pins can be used as segment outputs when so specified by the control data.	-	O	OPEN
KI1/S59 to KI5/S63	57 to 61	Key scan inputs These pins have built-in pull-down resistors. The KI1/S59 to KI5/S63 pins can be used as segment outputs when so specified by the control data.	-	I O	VSS OPEN
SYNCIO/S64	62	Segment Output for Master without Slave application. SYNC output signal for Master with Slave application and SYNC input signal for Slave application.	- - H	O O I	OPEN - -
CLKIO/S65	63	Segment Output for Master without Slave application. CLK output signal for Master with Slave application and CLK input signal for Slave application.	- - 	O O I	OPEN - -
S66/TESTIN	64	TESTIN Input for Master Application. Segment Output for Slave Application.	- -	I O	VDD OPEN
COM5/S67	65	COMMON / SEGMENT output for LCD driving Assigned as COMMON output in 1/5 Duty mode and SEGMENT output in 1/1 Duty, 1/3 Duty and 1/4 Duty modes	-	O	OPEN
COM4 to COM1	66 to 69	Common driver output pins. The frame frequency is fo[Hz].	-	O	-
MS	72	Master / Slave Control Switch L : Master, H : Slave	-	I	-
OSC_IN/S73	75	Segment output for displaying the display data transferred by serial data input. The pin OSC_IN/S73 can be used as external frequency input pin when set up by the control data.	-	I/O	OPEN
SCE	76	Serial data transfer inputs. Must be connected to the controller. SCE: Chip enable	H 	I	-
SCL	77	SCL: Synchronization clock	-	I	-
SDI	78	SDI: Transfer data	-	I	-
SDO	73	Output data	-	O	OPEN
VDD	70	Power supply pin of the IC A power voltage of 2.7V to 6.0V must be applied to this pin.	-	-	-
VSS	71	Power supply pin. Must be connected to Ground.	-	-	-

IO Equivalence Circuit

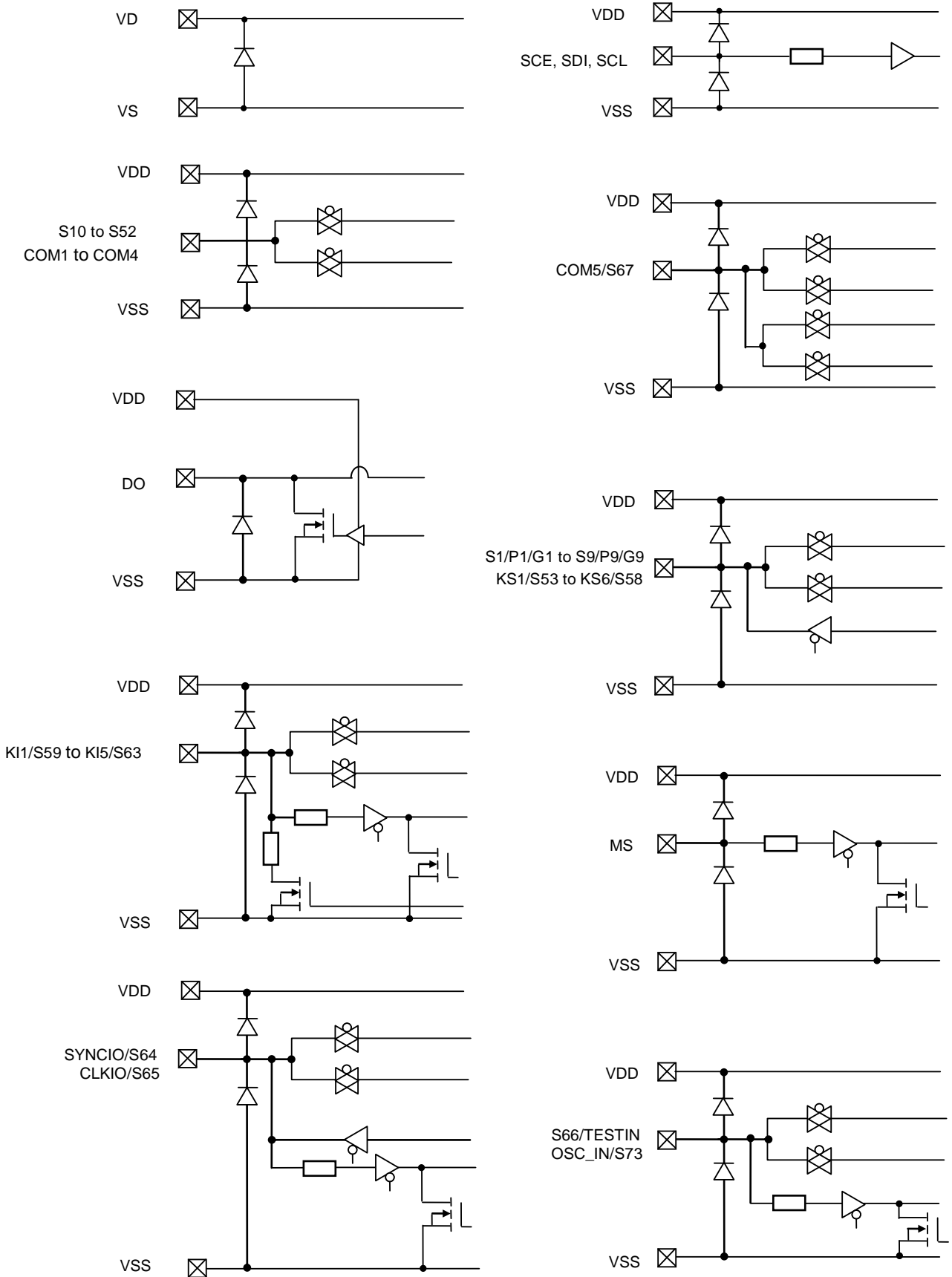

Figure 6. I/O Equivalent Circuit

Serial Data Transfer Formats

1. 1/5 Duty

(1) When SCL is stopped at the low level

(a) Master

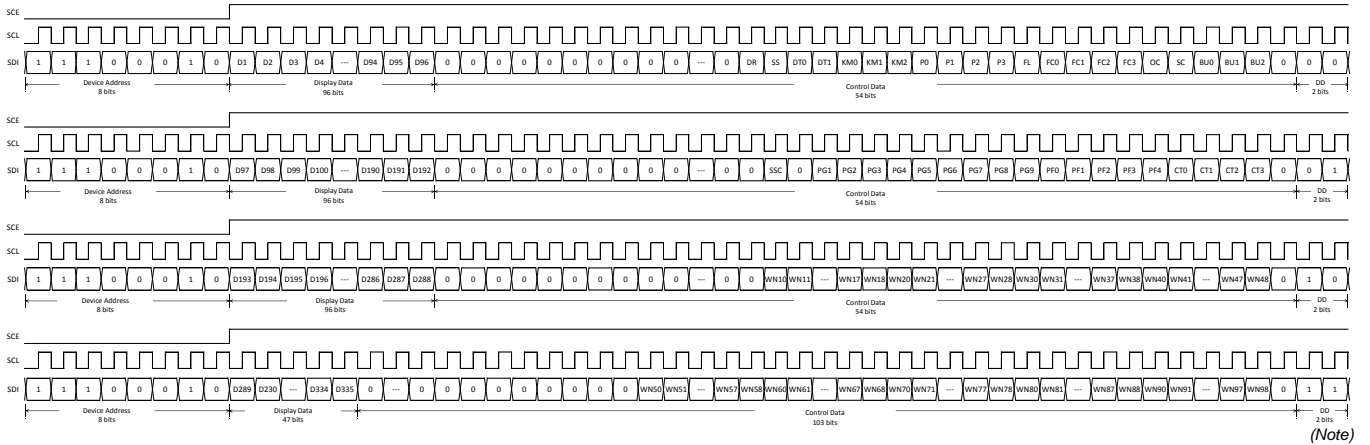

(b) Slave

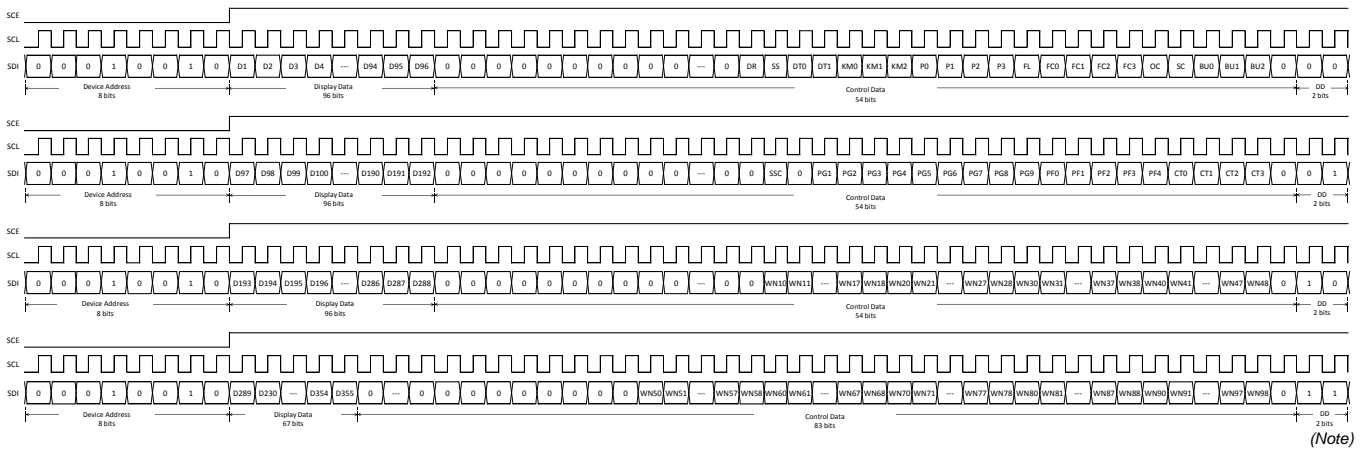
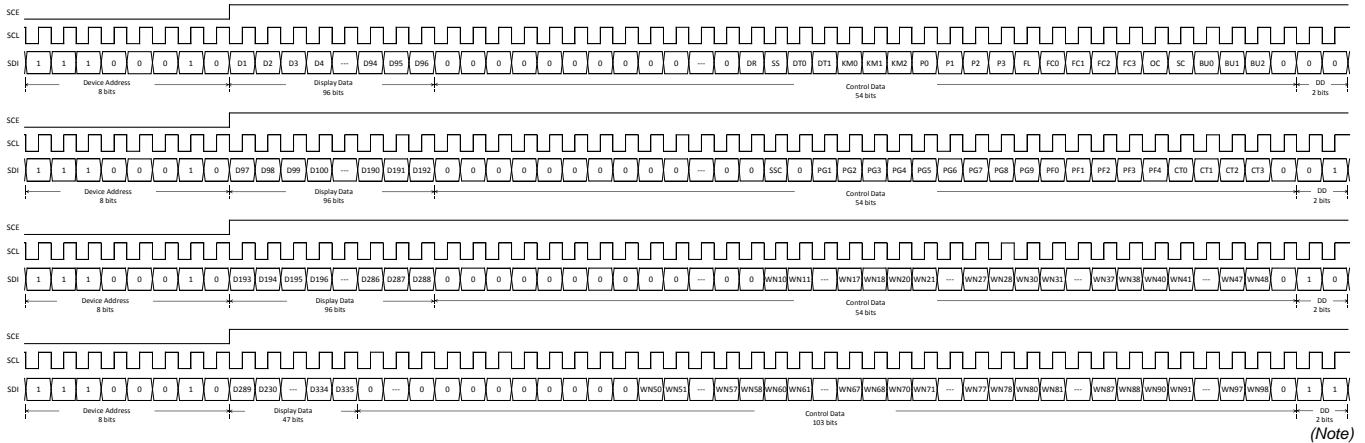

Figure 7. 3-SPI Data Transfer Format

(Note) DD is direction data.

Serial Data Transfer Formats – continued
 (2) When SCL is stopped at the high level

(a) Master



(Note)

(b) Slave

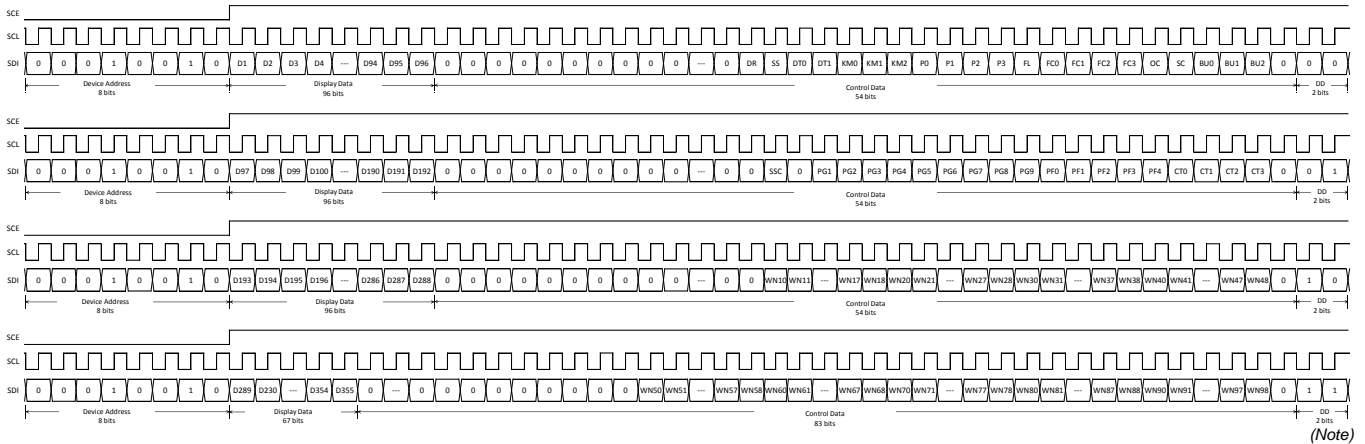

(Note)

Figure 8. 3-SPI Data Transfer Format

(Note) DD is direction data.

- Device code....."47H" for Master , "48H" for Slave
- KM0 to KM2.....Key Scan output pin/Segment output pin switching control data
- D1 to D335.....Display data for Master
- D1 to D355.....Display data for Slave
- SS.....Master Clock and Sync output pin/Segment output pin switching control data
- SSC.....SEG/COM output pin switching control data
- P0 to P3.....Segment/PWM/General-purpose output pin switching control data
- FL.....Line Inversion or Frame Inversion switching control data
- DR.....1/3 bias drive or 1/2 bias drive switching control data
- DT0 to DT1.....1/5 duty drive, 1/4 duty drive, 1/3 duty drive or Static drive switching control data
- FC0 to FC3.....Common/segment output waveform frame frequency switching control data
- OC.....Internal oscillator operating mode/External clock operating mode switching control data
- SC.....Segment on/off switching control data
- BU0 to BU2.....Normal mode/power-saving mode switching control data
- PG1 to PG9.....PWM/General-purpose output switching control data
- PF0 to PF4.....PWM output waveform frame frequency switching control data
- CT0 to CT3.....Display contrast switching control data
- W10 to W18, W20 to W28, W30 to W38, W40 to W48, W50 to W58, W60 to W68, W70 to W78, W80 to W88, W90 to W98
PWM output duty switching control data

When it is coincident with device code, BU91540KV-M capture display data and control data at falling edge of SCE.
 So, please transfer the bit number of send display data and control data as specified number in the above figure.
 Specified number of bits is 160bit (Device code: 8bit, Display data and Control data: 150bit, DD: 2bit)

Serial Data Transfer Formats – continued

2. 1/4 Duty

(1) When SCL is stopped at the low level

(a) Master

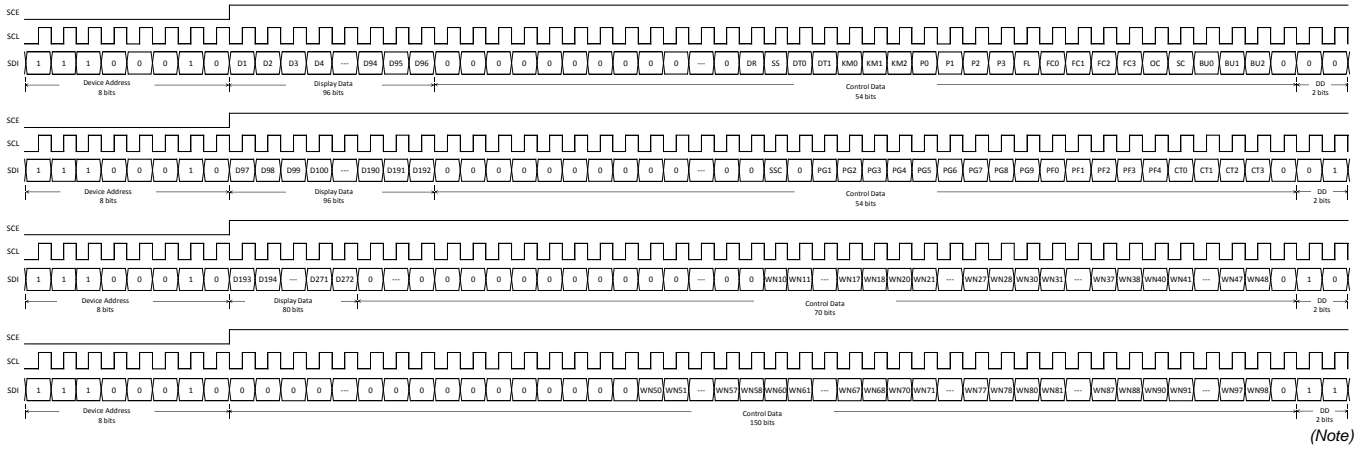

(Note)

(b) Slave

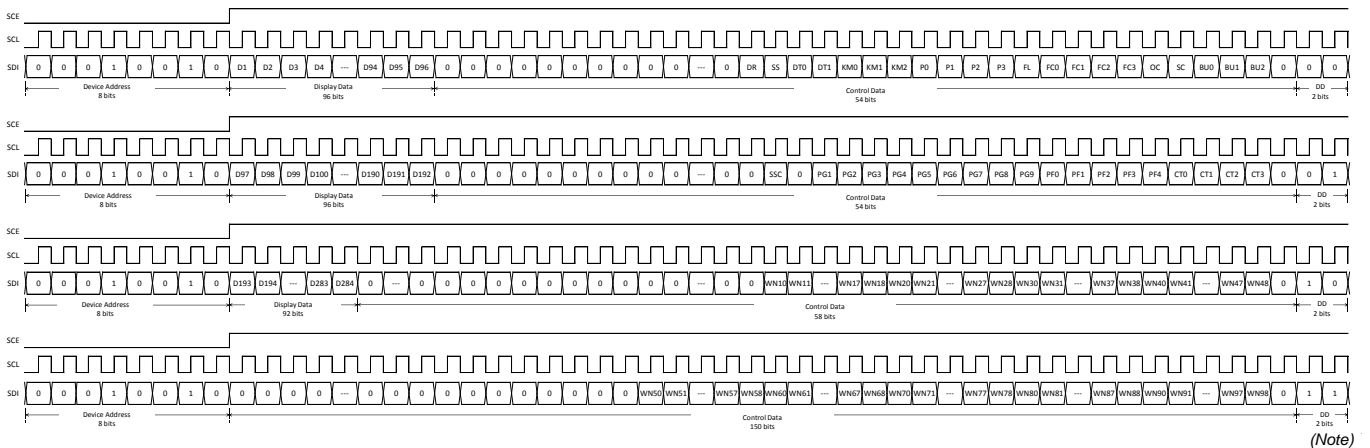

(Note)

Figure 9. 3-SPI Data Transfer Format

(Note) DD is direction data.

Serial Data Transfer Formats – continued

(2) When SCL is stopped at the high level

(a) Master

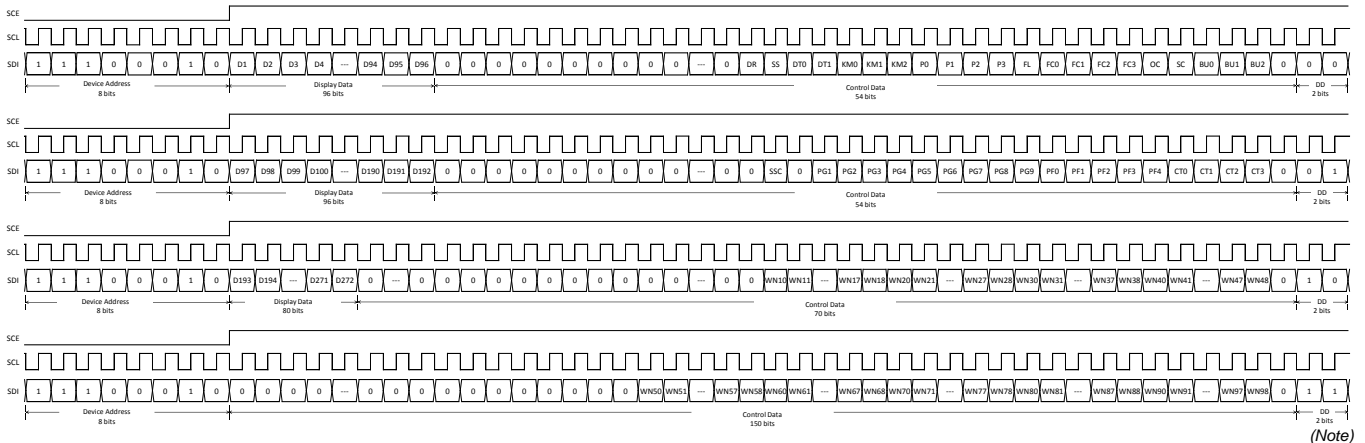

(Note)

(b) Slave

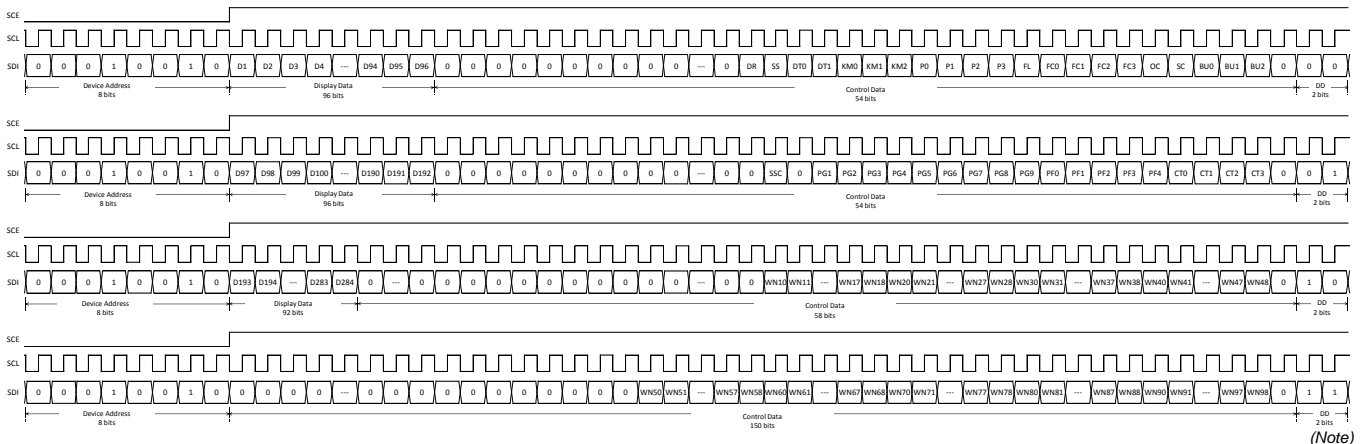

(Note)

Figure 10. 3-SPI Data Transfer Format

(Note) DD is direction data.

- Device code....."47H" for Master , "48H" for Slave
- KM0 to KM2.....Key Scan output pin/Segment output pin switching control data
- D1 to D272.....Display data for Master
- D1 to D284.....Display data for Slave
- SS.....Master Clock and Sync output pin/Segment output pin switching control data
- SSC.....SEG/COM output pin switching control data
- P0 to P3.....Segment/PWM/General-purpose output pin switching control data
- FL.....Line Inversion or Frame Inversion switching control data
- DR.....1/3 bias drive or 1/2 bias drive switching control data
- DT0 to DT1.....1/5 duty drive, 1/4 duty drive, 1/3 duty drive or Static drive switching control data
- FC0 to FC3.....Common/segment output waveform frame frequency switching control data
- OC.....Internal oscillator operating mode/External clock operating mode switching control data
- SC.....Segment on/off switching control data
- BU0 to BU2.....Normal mode/power-saving mode switching control data
- PG1 to PG9.....PWM/General-purpose output switching control data
- PF0 to PF4.....PWM output waveform frame frequency switching control data
- CT0 to CT3.....Display contrast switching control data
- W10 to W18, W20 to W28, W30 to W38, W40 to W48, W50 to W58, W60 to W68, W70 to W78, W80 to W88, W90 to W98
.....PWM output duty switching control data

When it is coincident with device code, BU91540KV-M capture display data and control data at falling edge of SCE. So, please transfer the bit number of send display data and control data as specified number in the above figure. Specified number of bits is 160bit (Device code: 8bit, Display data and Control data: 150bit, DD: 2bit)

Serial Data Transfer Formats – continued

3. 1/3 Duty

(1) When SCL is stopped at the low level

(a) Master

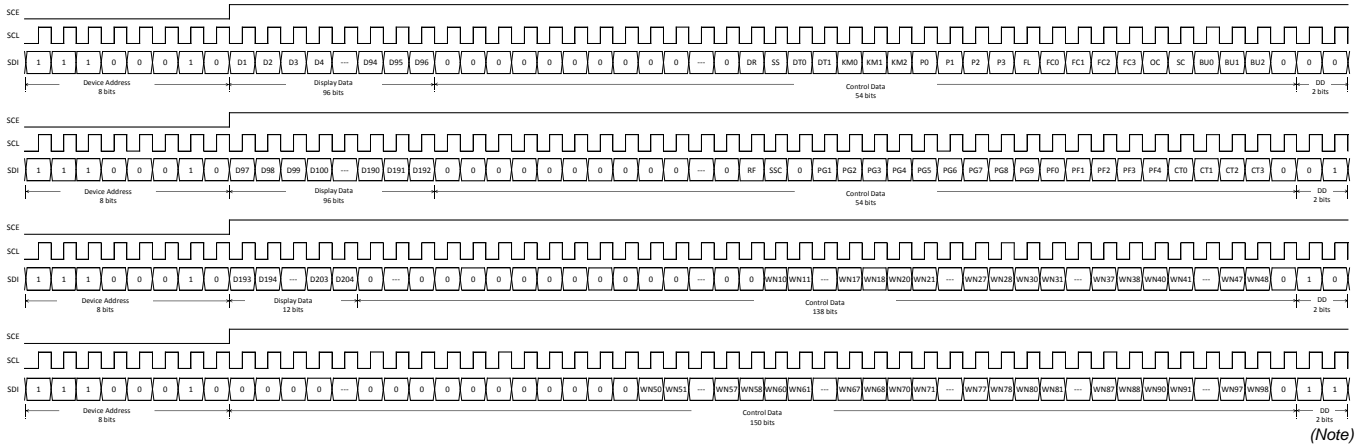

(b) Slave

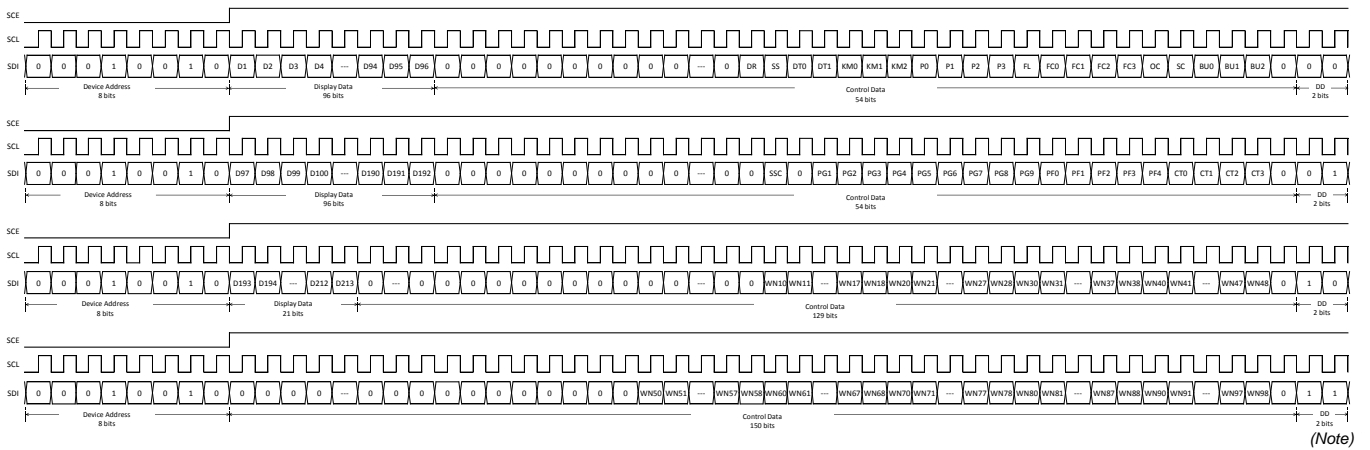

Figure 11. 3-SPI Data Transfer Format

(Note) DD is direction data.

Serial Data Transfer Formats – continued

(2) When SCL is stopped at the high level

(a) Master

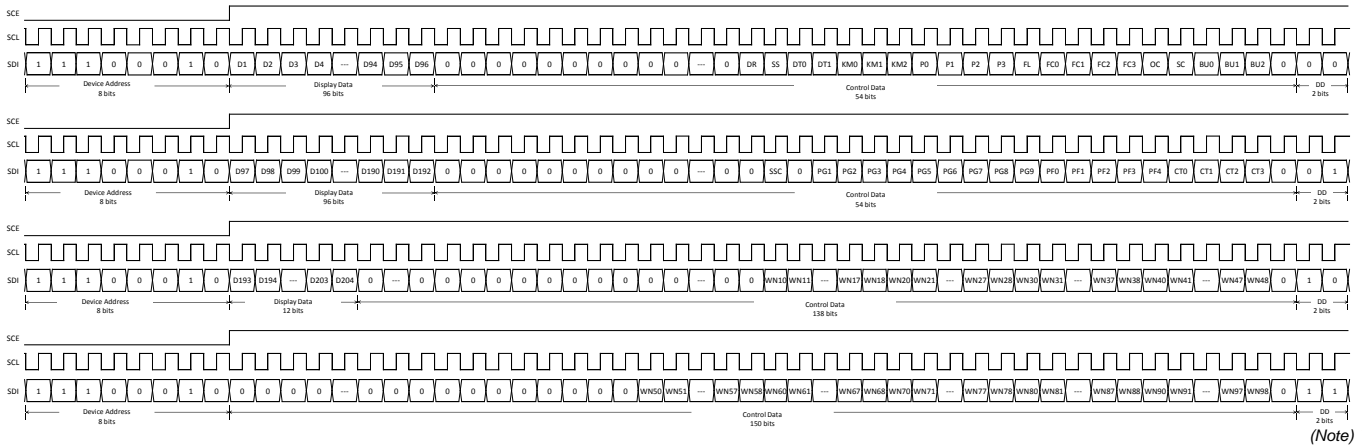

(b) Slave

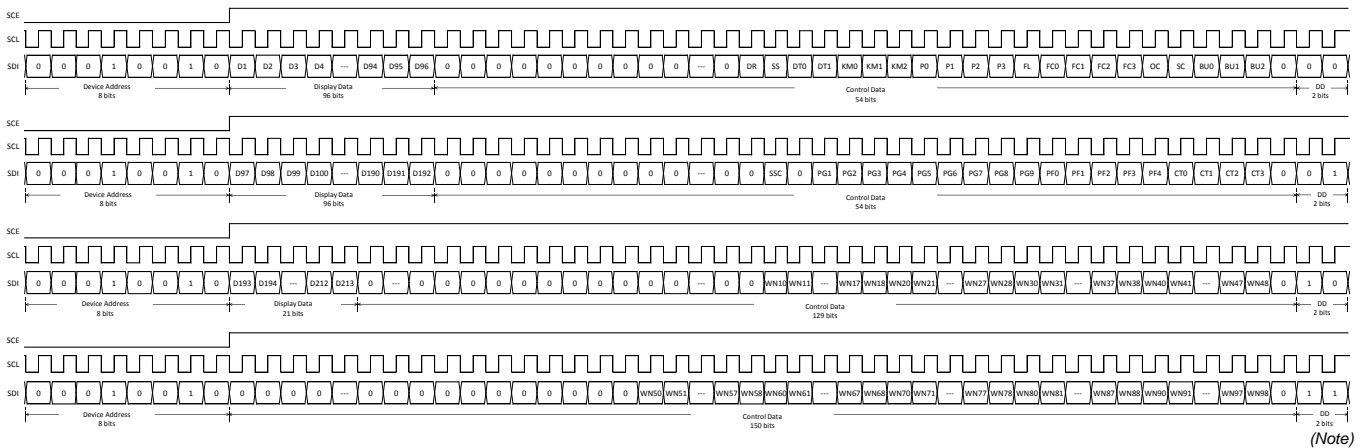

Figure 12. 3-SPI Data Transfer Format

(Note) DD is direction data.

- Device code....."47H" for Master , "48H" for Slave
- KM0 to KM2.....Key Scan output pin/Segment output pin switching control data
- D1 to D204.....Display data for Master
- D1 to D213.....Display data for Slave
- SS.....Master Clock and Sync output pin/Segment output pin switching control data
- SSC.....SEG/COM output pin switching control data
- P0 to P3.....Segment/PWM/General-purpose output pin switching control data
- FL.....Line Inversion or Frame Inversion switching control data
- DR.....1/3 bias drive or 1/2 bias drive switching control data
- DT0 to DT1.....1/5 duty drive, 1/4 duty drive, 1/3 duty drive or Static drive switching control data
- FC0 to FC3.....Common/segment output waveform frame frequency switching control data
- OC.....Internal oscillator operating mode/External clock operating mode switching control data
- SC.....Segment on/off switching control data
- BU0 to BU2.....Normal mode/power-saving mode switching control data
- PG1 to PG9.....PWM/General-purpose output switching control data
- PF0 to PF4.....PWM output waveform frame frequency switching control data
- CT0 to CT3.....Display contrast switching control data
- W10 to W18, W20 to W28, W30 to W38, W40 to W48, W50 to W58, W60 to W68, W70 to W78, W80 to W88, W90 to W98.....PWM output duty switching control data

When it is coincident with device code, BU91540KV-M capture display data and control data at falling edge of SCE. So, please transfer the bit number of send display data and control data as specified number in the above figure. Specified number of bits is 160bit (Device code: 8bit, Display data and Control data: 150bit, DD: 2bit)

Serial Data Transfer Formats – continued

(2) When SCL is stopped at the high level

(a) Master

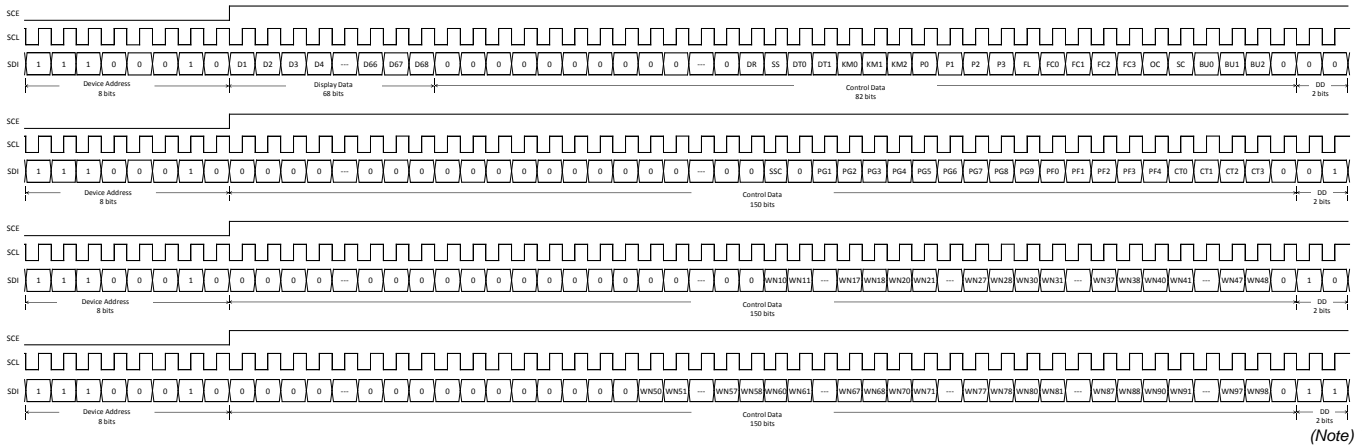

(Note)

(b) Slave

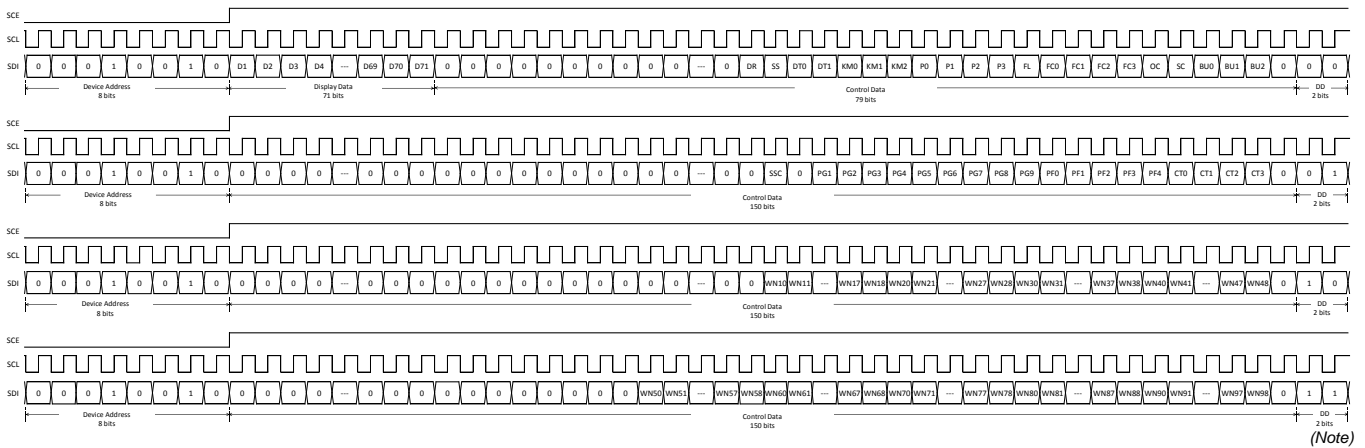

(Note)

Figure 14. 3-SPI Data Transfer Format

(Note) DD is direction data.

- Device code....."47H" for Master , "48H" for Slave
- KM0 to KM2.....Key Scan output pin/Segment output pin switching control data
- D1 to D68.....Display data for Master
- D1 to D71.....Display data for Slave
- SS.....Master Clock and Sync output pin/Segment output pin switching control data
- SSC.....SEG/COM output pin switching control data
- P0 to P3.....Segment/PWM/General-purpose output pin switching control data
- FL.....Line Inversion or Frame Inversion switching control data
- DR.....1/3 bias drive or 1/2 bias drive switching control data
- DT0 to DT1.....1/5 duty drive, 1/4 duty drive, 1/3 duty drive or Static drive switching control data
- FC0 to FC3.....Common/segment output waveform frame frequency switching control data
- OC.....Internal oscillator operating mode/External clock operating mode switching control data
- SC.....Segment on/off switching control data
- BU0 to BU2.....Normal mode/power-saving mode switching control data
- PG1 to PG9.....PWM/General-purpose output switching control data
- PF0 to PF4.....PWM output waveform frame frequency switching control data
- CT0 to CT3.....Display contrast switching control data
- W10 to W18, W20 to W28, W30 to W38, W40 to W48, W50 to W58, W60 to W68, W70 to W78, W80 to W88, W90 to W98.....PWM output duty switching control data

When it is coincident with device code, BU91540KV-M capture display data and control data at falling edge of SCE. So, please transfer the bit number of send display data and control data as specified number in the above figure. Specified number of bits is 160bit (Device code: 8bit, Display data and Control data: 150bit, DD: 2bit)

Control Data Functions

1. KM0, KM1 and KM2: Key Scan output pin/Segment output pin switching control data

These control data bits switch the functions of the KS1/S53 to KS6/S58 output pins between key scan output and segment output.

KM0	KM1	KM2	Output Pin State						Maximum Number of Input keys	Reset Condition
			KS1/S53	KS2/S54	KS3/S55	KS4/S56	KS5/S57	KS6/S58		
0	0	0	KS1	KS2	KS3	KS4	KS5	KS6	30	-
0	0	1	S53	KS2	KS3	KS4	KS5	KS6	25	-
0	1	0	S53	S54	KS3	KS4	KS5	KS6	20	-
0	1	1	S53	S54	S55	KS4	KS5	KS6	15	-
1	0	0	S53	S54	S55	S56	KS5	KS6	10	-
1	0	1	S53	S54	S55	S56	S57	KS6	5	-
1	1	0	S53	S54	S55	S56	S57	S58	0	-
1	1	1	S53	S54	S55	S56	S57	S58	0	○

In Slave chip of 2 chip mode, it is automatically set to all segment output.

2. P0, P1, P2, and P3: Segment / PWM / General-purpose output pin switching control data

These control bits are used to select the function of the S1/P1/G1 to S9/P9/G9 output pins (Segment Output Pins or PWM Output Pins or General-purpose Output Pins).

P0	P1	P2	P3	S1/P1/G1	S2/P2/G2	S3/P3/G3	S4/P4/G4	S5/P5/G5	S6/P6/G6	S7/P7/G7	S8/P8/G8	S9/P9/G9	Reset Condition
0	0	0	0	S1	S2	S3	S4	S5	S6	S7	S8	S9	-
0	0	0	1	P1/G1	S2	S3	S4	S5	S6	S7	S8	S9	-
0	0	1	0	P1/G1	P2/G2	S3	S4	S5	S6	S7	S8	S9	-
0	0	1	1	P1/G1	P2/G2	P3/G3	S4	S5	S6	S7	S8	S9	-
0	1	0	0	P1/G1	P2/G2	P3/G3	P4/G4	S5	S6	S7	S8	S9	-
0	1	0	1	P1/G1	P2/G2	P3/G3	P4/G4	P5/G5	S6	S7	S8	S9	-
0	1	1	0	P1/G1	P2/G2	P3/G3	P4/G4	P5/G5	P6/G6	S7	S8	S9	-
0	1	1	1	P1/G1	P2/G2	P3/G3	P4/G4	P5/G5	P6/G6	P7/G7	S8	S9	-
1	0	0	0	P1/G1	P2/G2	P3/G3	P4/G4	P5/G5	P6/G6	P7/G7	P8/G8	S9	-
1	0	0	1	P1/G1	P2/G2	P3/G3	P4/G4	P5/G5	P6/G6	P7/G7	P8/G8	P9/G9	-
1	0	1	0	S1	S2	S3	S4	S5	S6	S7	S8	S9	-
1	0	1	1	S1	S2	S3	S4	S5	S6	S7	S8	S9	-
1	1	0	0	S1	S2	S3	S4	S5	S6	S7	S8	S9	-
1	1	0	1	S1	S2	S3	S4	S5	S6	S7	S8	S9	-
1	1	1	0	S1	S2	S3	S4	S5	S6	S7	S8	S9	-
1	1	1	1	S1	S2	S3	S4	S5	S6	S7	S8	S9	○

PWM output or General-purpose output is selected by PGx(x = 1 to 9) control data bit.

When the General-purpose Output Pin Function is selected, the correspondence between the output pins and the respective display data is given in the table below.

Output Pins	Corresponding Display Data			
	1/5 Duty mode	1/4 Duty mode	1/3 Duty mode	Static mode
S1/P1/G1	D1	D1	D1	D1
S2/P2/G2	D6	D5	D4	D2
S3/P3/G3	D11	D9	D7	D3
S4/P4/G4	D16	D13	D10	D4
S5/P5/G5	D21	D17	D13	D4
S6/P6/G6	D26	D21	D16	D5
S7/P7/G7	D31	D25	D19	D7
S8/P8/G8	D36	D29	D22	D8
S9/P9/G9	D41	D33	D25	D9

When the General-purpose Output Pin Function is selected, the respective output pin outputs a "HIGH" level when its corresponding display data is set to "1". Likewise, it will output a "LOW" level, if its corresponding display data is set to "0". For example, at 1/4 Duty mode, S4/P4/G4 is used as a General-purpose Output Pin, if its corresponding display data D13 is set to "1", then S4/P4/G4 will output "HIGH" level. Likewise, if D13 is set to "0", then S4/P4/G4 will output "LOW" level.

3. FL: Line Inversion or Frame Inversion switching control data

This control data bit selects either line inversion mode or frame inversion mode.

FL	Inversion mode	Reset Condition
0	Line Inversion	○
1	Frame Inversion	-

Typically, when driving large capacitance LCD, Line inversion will increase the influence of crosstalk.

Regarding driving waveform, refer to [LCD Driving Waveforms](#).

Control Data Functions – continued

4. DR: 1/3 bias drive or 1/2 bias drive switching control data

This control data bit selects either 1/3 bias drive or 1/2 bias drive.

DR	Bias drive scheme	Reset Condition
0	1/3 bias	○
1	1/2 bias	-

5. SS: Master Clock and Sync output pin/Segment output pin switching control data

This control data bit switches the functions of the CLKIO/S64 and SYNCIO/S65 output pins of master.

SS	Output Pin State		Reset Condition
	CLKIO/S64	SYNCIO/S65	
0	S64	S65	○
1	CLKIO	SYNCIO	-

In Slave chip of 2 chip mode, it is automatically set to CLKIO and SYNCIO.

6. DT0, DT1: 1/5 duty drive, 1/4 duty drive, 1/3 duty drive or Static switching control data

These control data bits select either 1/5 duty drive, 1/4 duty drive, 1/3 duty drive or Static

DT0	DT1	Duty drive scheme	Reset Condition
0	0	Static drive	-
0	0	1/3 duty drive	-
0	1	1/4 duty drive	○
1	1	1/5 duty drive	-

7. FC0, FC1, FC2 and FC3: Common/segment output waveform frame frequency switching control data

These control data bits set the frame frequency for common and segment output waveforms.

FC0	FC1	FC2	FC3	Frame Frequency fo(Hz)	Reset Condition
0	0	0	0	$f_{osc}^{(Note)} / 12288$	○
0	0	0	1	$f_{osc} / 10752$	-
0	0	1	0	$f_{osc} / 9216$	-
0	0	1	1	$f_{osc} / 7680$	-
0	1	0	0	$f_{osc} / 6144$	-
0	1	0	1	$f_{osc} / 4608$	-
0	1	1	0	$f_{osc} / 3840$	-
0	1	1	1	$f_{osc} / 3072$	-
1	0	0	0	$f_{osc} / 2880$	-
1	0	0	1	$f_{osc} / 2688$	-
1	0	1	0	$f_{osc} / 2496$	-
1	0	1	1	$f_{osc} / 2304$	-
1	1	0	0	$f_{osc} / 2112$	-
1	1	0	1	$f_{osc} / 1920$	-
1	1	1	0	$f_{osc} / 1728$	-
1	1	1	1	$f_{osc} / 1536$	-

(Note) f_{osc} : Internal Oscillation Frequency (600 kHz Typ)

Control Data Functions – continued

8. OC: Internal oscillator operating mode/External clock operating mode switching control data
This control data bit selects oscillation mode.

OC	Operating mode	In/Out pin(OSC_IN/S73) status	Reset Condition
0	Internal oscillator	S73 (segment output)	○
1	External Clock	OSC_IN (clock input)	-

<External Clock input timing function>

Internal oscillation / external clock select signal behavior is below.
Input external clock after serial data sending.

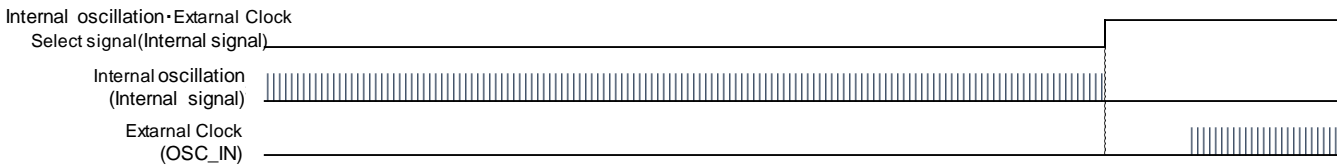
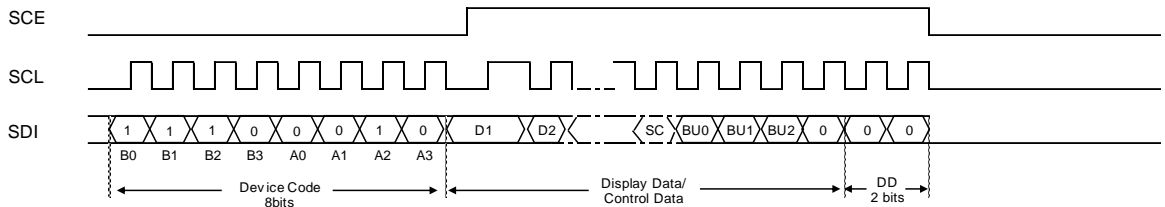

9. SC: Segment on/off switching control data
This control data bit controls the on/off state of the segments.

SC	Display state	Reset Condition
0	on	-
1	off	○

Note that when the segments are turned off by setting SC to “1”, the segments are turned off by outputting segment off waveforms from the segment output pins.

10. BU0, BU1 and BU2: Normal mode/power-saving mode switching control data
These control data bits select either normal mode or power-saving mode.

BU0	BU1	BU2	Mode	OSC Oscillator	Segment outputs	Output Pin States During Key Scan Standby						Reset Condition	
						Common outputs	KS1	KS2	KS3	KS4	KS5		KS6
0	0	0	Power-saving	Stopped	Low(VSS)	Operating	H	H	H	H	H	H	-
0	0	1				L	L	L	L	L	L	H	-
0	1	0				L	L	L	L	H	H	H	-
0	1	1				L	L	L	H	H	H	H	-
1	0	0				L	L	H	H	H	H	H	-
1	0	1				L	L	H	H	H	H	H	-
1	1	0				H	H	H	H	H	H	H	-
1	1	1				H	H	H	H	H	H	H	○

Power-saving mode status: S1/P1/G1 to S9/P9/G9 = active only General-purpose output
S10 to OSC_IN/S73 = low (VSS)
COM1 to COM5 = low (VSS)
Shut off current to the LCD drive bias voltage generation circuit
Stop the Internal oscillation circuit
However, serial data transfer is possible when at Power-saving mode.

11. SSC: SEG/COM output pin switching control data
This control data bit selects SEG or COM output for Slave.

SSC	Output Pin State					Reset Condition
	COM5/S67	COM4/S68	COM3/S69	COM2/S70	COM1/S71	
0	S67	S68	S69	S70	S71	○
1	COM5	COM4	COM3	COM2	COM1	-

This option is not available in Master mode.

Control Data Functions – continued

12. PG1, PG2, PG3, PG4, PG5, PG6, PG7, PG8 and PG9: PWM/General-purpose output switching control data
 This control data bit select either PWM output or General-purpose output of Sx/Px/Gx pins. (x = 1 to 9)

PGx(x = 1 to 9)	Mode	Reset Condition
0	PWM Output	○
1	General-purpose Output	-

<PWM<->GPO Changing function>

Normal behavior of changing GPO to PWM is below.

- PWM operation is started by command import timing of DD: 01 during GPO → PWM change.
- Please take care of reflect timing of new duty setting of DD: 10 and DD: 11 are from the next PWM.

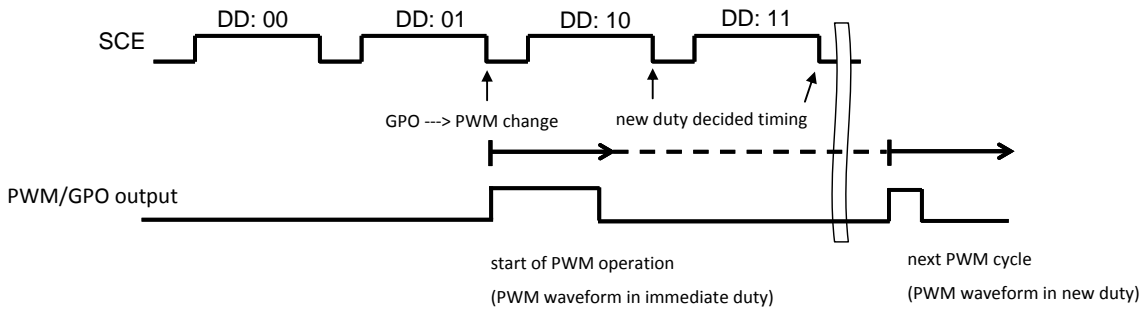

In order to avoid this operation, please input commands in reverse as below.

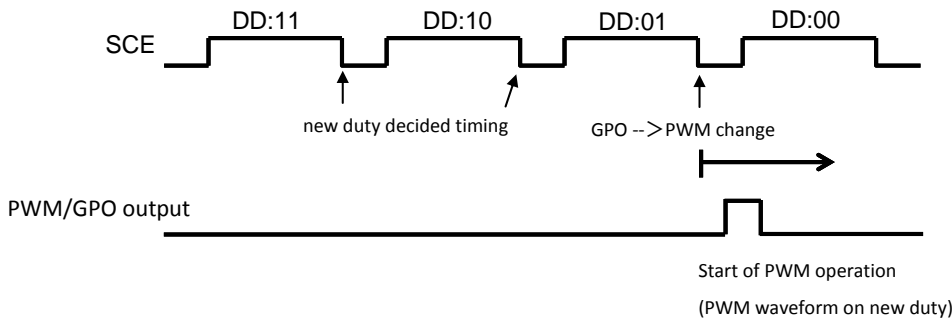

13. PF0, PF1, PF2, PF3 and PF4: PWM output waveform frame frequency switching control data
 These control data bits set the frame frequency for PWM output waveforms.

PF0	PF1	PF2	PF3	PF4	PWM output Frame Frequency fp(Hz)	Reset Condition
0	0	0	0	0	$f_{osc} / 4096$	○
0	0	0	0	1	$f_{osc} / 3840$	-
0	0	0	1	0	$f_{osc} / 3584$	-
0	0	0	1	1	$f_{osc} / 3328$	-
0	0	1	0	0	$f_{osc} / 3072$	-
0	0	1	0	1	$f_{osc} / 2816$	-
0	0	1	1	0	$f_{osc} / 2560$	-
0	0	1	1	1	$f_{osc} / 2304$	-
0	1	0	0	0	$f_{osc} / 2048$	-
0	1	0	0	1	$f_{osc} / 1792$	-
0	1	0	1	0	$f_{osc} / 1536$	-
0	1	0	1	1	$f_{osc} / 1280$	-
0	1	1	0	0	$f_{osc} / 1024$	-
0	1	1	0	1	$f_{osc} / 768$	-
0	1	1	1	0	$f_{osc} / 512$	-
0	1	1	1	1	$f_{osc} / 256$	-
1	0	0	0	0	$f_{osc} / 128$	-
...
1	1	1	1	1	$f_{osc} / 128$	-

Control Data Functions – continued

14. CT0, CT1, CT2 and CT3: Display Contrast switching control data

These control data bits set display contrast

CT0	CT1	CT2	CT3	LCD Drive bias voltage for VLCD Level	Reset Condition
0	0	0	0	1.000*VDD	○
0	0	0	1	0.975*VDD (Note)	-
0	0	1	0	0.950*VDD (Note)	-
0	0	1	1	0.925*VDD (Note)	-
0	1	0	0	0.900*VDD	-
0	1	0	1	0.875*VDD	-
0	1	1	0	0.850*VDD	-
0	1	1	1	0.825*VDD	-
1	0	0	0	0.800*VDD	-
1	0	0	1	0.775*VDD	-
1	0	1	0	0.750*VDD	-
1	0	1	1	0.725*VDD	-
1	1	0	0	0.700*VDD	-
1	1	0	1	0.675*VDD	-
1	1	1	0	0.650*VDD	-
1	1	1	1	0.625*VDD	-

These control data bits set VLCD voltage level (the max level voltage of LCD driving voltage).

(Note) [CT0,CT1,CT2,CT3] = [0,0,0,1], [0,0,1,0], [0,0,1,1] are disabled settings.

Avoid setting VLCD voltage under 2.5V.

And ensure "VDD - VLCD > 0.6" condition is satisfied.

Unstable IC output voltage may result if the above conditions are not satisfied.

The relationship of LCD display contrast setting and VLCD voltage

CT Setting	formula	VDD= 6.000	VDD= 5.500	VDD= 5.000	VDD= 4.500	VDD= 4.000	VDD= 3.000	V
0	VDD	VLCD= 6.000	VLCD= 5.500	VLCD= 5.000	VLCD= 4.500	VLCD= 4.000	VLCD= 3.000	V
1	0.975*VDD	VLCD= 5.850	VLCD= 5.363	VLCD= 4.875	VLCD= 4.388	VLCD= 3.900	VLCD= 2.925	V
2	0.950*VDD	VLCD= 5.700	VLCD= 5.225	VLCD= 4.750	VLCD= 4.275	VLCD= 3.800	VLCD= 2.850	V
3	0.925*VDD	VLCD= 5.550	VLCD= 5.088	VLCD= 4.625	VLCD= 4.163	VLCD= 3.700	VLCD= 2.775	V
4	0.900*VDD	VLCD= 5.400	VLCD= 4.950	VLCD= 4.500	VLCD= 4.050	VLCD= 3.600	VLCD= 2.700	V
5	0.875*VDD	VLCD= 5.250	VLCD= 4.813	VLCD= 4.375	VLCD= 3.938	VLCD= 3.500	VLCD= 2.625	V
6	0.850*VDD	VLCD= 5.100	VLCD= 4.675	VLCD= 4.250	VLCD= 3.825	VLCD= 3.400	VLCD= 2.550	V
7	0.825*VDD	VLCD= 4.950	VLCD= 4.538	VLCD= 4.125	VLCD= 3.713	VLCD= 3.300	VLCD= 2.475	V
8	0.800*VDD	VLCD= 4.800	VLCD= 4.400	VLCD= 4.000	VLCD= 3.600	VLCD= 3.200	VLCD= 2.400	V
9	0.775*VDD	VLCD= 4.650	VLCD= 4.263	VLCD= 3.875	VLCD= 3.488	VLCD= 3.100	VLCD= 2.325	V
10	0.750*VDD	VLCD= 4.500	VLCD= 4.125	VLCD= 3.750	VLCD= 3.375	VLCD= 3.000	VLCD= 2.250	V
11	0.725*VDD	VLCD= 4.350	VLCD= 3.988	VLCD= 3.625	VLCD= 3.263	VLCD= 2.900	VLCD= 2.175	V
12	0.700*VDD	VLCD= 4.200	VLCD= 3.850	VLCD= 3.500	VLCD= 3.150	VLCD= 2.800	VLCD= 2.100	V
13	0.675*VDD	VLCD= 4.050	VLCD= 3.713	VLCD= 3.375	VLCD= 3.038	VLCD= 2.700	VLCD= 2.025	V
14	0.650*VDD	VLCD= 3.900	VLCD= 3.575	VLCD= 3.250	VLCD= 2.925	VLCD= 2.600	VLCD= 1.950	V
15	0.625*VDD	VLCD= 3.750	VLCD= 3.438	VLCD= 3.125	VLCD= 2.813	VLCD= 2.500	VLCD= 1.875	V

 Disabled

Control Data Functions – continued

15. W10 to W18^(Note), W20 to W28, W30 to W38, W40 to W48, W50 to W58, W60 to W68, W70 to W78, W80 to W88 and W90 to W98: PWM output waveform duty switching control data.

These control data bits set the high level pulse width (duty) for PWM output waveforms.

Table below shows PWM high level pulse width when PF0 to PF4 command setting is [PF0, PF1, PF2, PF3, PF4] = [0,x,x,x,x]

n = 1 to 9, Tp = 1/fp

Wn0	Wn1	Wn2	Wn3	Wn4	Wn5	Wn6	Wn7	Wn8	PWM duty	Reset Condition
0	0	0	0	0	0	0	0	0	(0/256) x Tp	○
0	0	0	0	0	0	0	0	1	(1/256) x Tp	-
0	0	0	0	0	0	0	1	0	(2/256) x Tp	-
0	0	0	0	0	0	0	1	1	(3/256) x Tp	-
0	0	0	0	0	0	1	0	0	(4/256) x Tp	-
0	0	0	0	0	0	1	0	1	(5/256) x Tp	-
0	0	0	0	0	0	1	1	0	(6/256) x Tp	-
0	0	0	0	0	0	1	1	1	(7/256) x Tp	-
0	0	0	0	0	1	0	0	0	(8/256) x Tp	-
0	0	0	0	0	1	0	0	1	(9/256) x Tp	-
0	0	0	0	0	1	0	1	0	(10/256) x Tp	-
0	0	0	0	0	1	0	1	1	(11/256) x Tp	-
0	0	0	0	0	1	1	0	0	(12/256) x Tp	-
0	0	0	0	0	1	1	0	1	(13/256) x Tp	-
0	0	0	0	0	1	1	1	0	(14/256) x Tp	-
0	0	0	0	0	1	1	1	1	(15/256) x Tp	-
0	0	0	0	1	0	0	0	0	(16/256) x Tp	-
0	0	0	0	1	0	0	0	1	(17/256) x Tp	-
0	0	0	0	1	0	0	1	0	(18/256) x Tp	-
0	0	0	0	1	0	0	1	1	(19/256) x Tp	-
0	0	0	0	1	0	1	0	0	(20/256) x Tp	-
...
0	1	1	1	0	1	0	1	1	(235/256) x Tp	-
0	1	1	1	0	1	1	0	0	(236/256) x Tp	-
0	1	1	1	0	1	1	0	1	(237/256) x Tp	-
0	1	1	1	0	1	1	1	0	(238/256) x Tp	-
0	1	1	1	0	1	1	1	1	(239/256) x Tp	-
0	1	1	1	1	0	0	0	0	(240/256) x Tp	-
0	1	1	1	1	0	0	0	1	(241/256) x Tp	-
0	1	1	1	1	0	0	1	0	(242/256) x Tp	-
0	1	1	1	1	0	0	1	1	(243/256) x Tp	-
0	1	1	1	1	0	1	0	0	(244/256) x Tp	-
0	1	1	1	1	0	1	0	1	(245/256) x Tp	-
0	1	1	1	1	0	1	1	0	(246/256) x Tp	-
0	1	1	1	1	0	1	1	1	(247/256) x Tp	-
0	1	1	1	1	1	0	0	0	(248/256) x Tp	-
0	1	1	1	1	1	0	0	1	(249/256) x Tp	-
0	1	1	1	1	1	0	1	0	(250/256) x Tp	-
0	1	1	1	1	1	0	1	1	(251/256) x Tp	-
0	1	1	1	1	1	1	0	0	(252/256) x Tp	-
0	1	1	1	1	1	1	0	1	(253/256) x Tp	-
0	1	1	1	1	1	1	1	0	(254/256) x Tp	-
0	1	1	1	1	1	1	1	1	(255/256) x Tp	-
1	0	0	0	0	0	0	0	0	(256/256) x Tp	-
1	0	0	0	0	0	0	0	1	(256/256) x Tp	-
1	0	0	0	0	0	0	1	0	(256/256) x Tp	-
1	0	0	0	0	0	0	1	1	(256/256) x Tp	-
...
1	1	1	1	1	1	1	0	0	(256/256) x Tp	-
1	1	1	1	1	1	1	0	1	(256/256) x Tp	-
1	1	1	1	1	1	1	1	0	(256/256) x Tp	-
1	1	1	1	1	1	1	1	1	(256/256) x Tp	-

(Note) W10 to W18:S1/P1/G1 PWM duty data
 W20 to W28:S2/P2/G2 PWM duty data
 W30 to W38:S3/P3/G3 PWM duty data
 W40 to W48:S4/P4/G4 PWM duty data
 W50 to W58:S5/P5/G5 PWM duty data
 W60 to W68:S6/P6/G6 PWM duty data
 W70 to W78:S7/P7/G7 PWM duty data
 W80 to W88:S8/P8/G8 PWM duty data
 W90 to W98:S9/P9/G9 PWM duty data

Control Data Functions – continued

Table below shows PWM high level pulse width when PF0 to PF4 command setting is [PF0, PF1, PF2, PF3, PF4] = [0,x,x,x,x] n = 1 to 9, Tp = 1/fp

Wn0	Wn1	Wn2	Wn3	Wn4	Wn5	Wn6	Wn7	Wn8	PWM duty	Reset Condition
0	0	0	0	0	0	0	0	0	(0/128) x Tp	○
0	0	0	0	0	0	0	0	1	(1/128) x Tp	-
0	0	0	0	0	0	0	1	0	(2/128) x Tp	-
0	0	0	0	0	0	0	1	1	(3/128) x Tp	-
0	0	0	0	0	0	1	0	0	(4/128) x Tp	-
0	0	0	0	0	0	1	0	1	(5/128) x Tp	-
0	0	0	0	0	0	1	1	0	(6/128) x Tp	-
0	0	0	0	0	0	1	1	1	(7/128) x Tp	-
0	0	0	0	0	1	0	0	0	(8/128) x Tp	-
0	0	0	0	0	1	0	0	1	(9/128) x Tp	-
0	0	0	0	0	1	0	1	0	(10/128) x Tp	-
0	0	0	0	0	1	0	1	1	(11/128) x Tp	-
0	0	0	0	0	1	1	0	0	(12/128) x Tp	-
0	0	0	0	0	1	1	0	1	(13/128) x Tp	-
0	0	0	0	0	1	1	1	0	(14/128) x Tp	-
0	0	0	0	0	1	1	1	1	(15/128) x Tp	-
0	0	0	0	1	0	0	0	0	(16/128) x Tp	-
0	0	0	0	1	0	0	0	1	(17/128) x Tp	-
0	0	0	0	1	0	0	1	0	(18/128) x Tp	-
0	0	0	0	1	0	0	1	1	(19/128) x Tp	-
0	0	0	0	1	0	1	0	0	(20/128) x Tp	-
...
0	1	1	1	0	1	0	1	1	(107/128) x Tp	-
0	1	1	1	0	1	1	0	0	(108/128) x Tp	-
0	1	1	1	0	1	1	0	1	(109/128) x Tp	-
0	1	1	1	0	1	1	1	0	(110/128) x Tp	-
0	1	1	1	0	1	1	1	1	(111/128) x Tp	-
0	1	1	1	1	0	0	0	0	(112/128) x Tp	-
0	1	1	1	1	0	0	0	1	(113/128) x Tp	-
0	1	1	1	1	0	0	1	0	(114/128) x Tp	-
0	1	1	1	1	0	0	1	1	(115/128) x Tp	-
0	1	1	1	1	0	1	0	0	(116/128) x Tp	-
0	1	1	1	1	0	1	0	1	(117/128) x Tp	-
0	1	1	1	1	0	1	1	0	(118/128) x Tp	-
0	1	1	1	1	0	1	1	1	(119/128) x Tp	-
0	1	1	1	1	1	0	0	0	(120/128) x Tp	-
0	1	1	1	1	1	0	0	1	(121/128) x Tp	-
0	1	1	1	1	1	0	1	0	(122/128) x Tp	-
0	1	1	1	1	1	0	1	1	(123/128) x Tp	-
0	1	1	1	1	1	1	0	0	(124/128) x Tp	-
0	1	1	1	1	1	1	0	1	(125/128) x Tp	-
0	1	1	1	1	1	1	1	0	(126/128) x Tp	-
0	1	1	1	1	1	1	1	1	(127/128) x Tp	-
1	0	0	0	0	0	0	0	0	(128/128) x Tp	-
1	0	0	0	0	0	0	0	1	(128/128) x Tp	-
1	0	0	0	0	0	0	1	0	(128/128) x Tp	-
1	0	0	0	0	0	0	1	1	(128/128) x Tp	-
...
1	1	1	1	1	1	1	0	0	(128/128) x Tp	-
1	1	1	1	1	1	1	0	1	(128/128) x Tp	-
1	1	1	1	1	1	1	1	0	(128/128) x Tp	-
1	1	1	1	1	1	1	1	1	(128/128) x Tp	-

(Note) W10 to W18:S1/P1/G1 PWM duty data
 W20 to W28:S2/P2/G2 PWM duty data
 W30 to W38:S3/P3/G3 PWM duty data
 W40 to W48:S4/P4/G4 PWM duty data
 W50 to W58:S5/P5/G5 PWM duty data
 W60 to W68:S6/P6/G6 PWM duty data
 W70 to W78:S7/P7/G7 PWM duty data
 W80 to W88:S8/P8/G8 PWM duty data
 W90 to W98:S9/P9/G9 PWM duty data

Display Data and Output Pin Correspondence

1.1/5 Duty Master

Output Pin ^(Note)	COM1	COM2	COM3	COM4	COM5
S1/P1/G1	D1	D2	D3	D4	D5
S2/P2/G2	D6	D7	D8	D9	D10
S3/P3/G3	D11	D12	D13	D14	D15
S4/P4/G4	D16	D17	D18	D19	D20
S5/P5/G5	D21	D22	D23	D24	D25
S6/P6/G6	D26	D27	D28	D29	D30
S7/P7/G7	D31	D32	D33	D34	D35
S8/P8/G8	D36	D37	D38	D39	D40
S9/P9/G9	D41	D42	D43	D44	D45
S10	D46	D47	D48	D49	D50
S11	D51	D52	D53	D54	D55
S12	D56	D57	D58	D59	D60
S13	D61	D62	D63	D64	D65
S14	D66	D67	D68	D69	D70
S15	D71	D72	D73	D74	D75
S16	D76	D77	D78	D79	D80
S17	D81	D82	D83	D84	D85
S18	D86	D87	D88	D89	D90
S19	D91	D92	D93	D94	D95
S20	D96	D97	D98	D99	D100
S21	D101	D102	D103	D104	D105
S22	D106	D107	D108	D109	D110
S23	D111	D112	D113	D114	D115
S24	D116	D117	D118	D119	D120
S25	D121	D122	D123	D124	D125
S26	D126	D127	D128	D129	D130
S27	D131	D132	D133	D134	D135
S28	D136	D137	D138	D139	D140
S29	D141	D142	D143	D144	D145
S30	D146	D147	D148	D149	D150
S31	D151	D152	D153	D154	D155
S32	D156	D157	D158	D159	D160
S33	D161	D162	D163	D164	D165
S34	D166	D167	D168	D169	D170
S35	D171	D172	D173	D174	D175
S36	D176	D177	D178	D179	D180
S37	D181	D182	D183	D184	D185
S38	D186	D187	D188	D189	D190
S39	D191	D192	D193	D194	D195
S40	D196	D197	D198	D199	D200
S41	D201	D202	D203	D204	D205
S42	D206	D207	D208	D209	D210
S43	D211	D212	D213	D214	D215
S44	D216	D217	D218	D219	D220
S45	D221	D222	D223	D224	D225
S46	D226	D227	D228	D229	D230
S47	D231	D232	D233	D234	D235
S48	D236	D237	D238	D239	D240
S49	D241	D242	D243	D244	D245
S50	D246	D247	D248	D249	D250
S51	D251	D252	D253	D254	D255
S52	D256	D257	D258	D259	D260
KS1/S53	D261	D262	D263	D264	D265
KS2/S54	D266	D267	D268	D269	D270
KS3/S55	D271	D272	D273	D274	D275
KS4/S56	D276	D277	D278	D279	D280
KS5/S57	D281	D282	D283	D284	D285
KS6/S58	D286	D287	D288	D289	D290
KI1/S59	D291	D292	D293	D294	D295
KI2/S60	D296	D297	D298	D299	D300
KI3/S61	D301	D302	D303	D304	D305
KI4/S62	D306	D307	D308	D309	D310
KI5/S63	D311	D312	D313	D314	D315

Display Data and Output Pin Correspondence – continued

Output Pin ^(Note)	COM1	COM2	COM3	COM4	COM5
CLKIO/S64	D316	D317	D318	D319	D320
SYNCIO/S65	D321	D322	D323	D324	D325
S66/TESTIN					
COM5/S67					
COM4/S68					
COM3/S69					
COM2/S70					
COM1/S71					
S72	D326	D327	D328	D329	D330
OSC_IN/S73	D331	D332	D333	D334	D335

(Note) The Segment Output Pin function is assumed to be selected for the output pins – S1/P1/G1 to S9/P9/G9, KS1/S53 to KS6/S58, K11/S59 to K15/S63, OSC_IN/S73. Also, COM5/S67 pin is used as Common output.

During 1 chip mode, S66/TESTIN functions as TESTIN input.

During 2 chip mode(Master with Slave), CLKIO/S64 and SYNCIO/S65 function as CLK and SYNC outputs.

To illustrate further, the states of the S21 output pin is given in the table below.

Display data					State of S21 Output Pin
D101	D102	D103	D104	D105	
0	0	0	0	0	LCD Segments corresponding to COM1 to COM5 are OFF.
0	0	0	0	1	LCD Segment corresponding to COM5 is ON.
0	0	0	1	0	LCD Segment corresponding to COM4 is ON.
0	0	0	1	1	LCD Segments corresponding to COM4 and COM5 are ON.
0	0	1	0	0	LCD Segment corresponding to COM3 is ON.
0	0	1	0	1	LCD Segments corresponding to COM3 and COM5 are ON.
0	0	1	1	0	LCD Segments corresponding to COM3 and COM4 are ON.
0	0	1	1	1	LCD Segments corresponding to COM3, COM4 and COM5 are ON.
0	1	0	0	0	LCD Segment corresponding to COM2 is ON.
0	1	0	0	1	LCD Segments corresponding to COM2 and COM5 are ON.
0	1	0	1	0	LCD Segments corresponding to COM2 and COM4 are ON.
0	1	0	1	1	LCD Segments corresponding to COM2, COM4 and COM5 are ON.
0	1	1	0	0	LCD Segments corresponding to COM2 and COM3 are ON.
0	1	1	0	1	LCD Segments corresponding to COM2, COM3, and COM5 are ON.
0	1	1	1	0	LCD Segments corresponding to COM2, COM3, and COM4 are ON.
0	1	1	1	1	LCD Segments corresponding to COM2, COM3, COM4 and COM5 are ON.
1	0	0	0	0	LCD Segment corresponding to COM1 is ON.
1	0	0	0	1	LCD Segment corresponding to COM1 and COM5 are ON.
1	0	0	1	0	LCD Segment corresponding to COM1 and COM4 are ON.
1	0	0	1	1	LCD Segment corresponding to COM1, COM4 and COM5 are ON.
1	0	1	0	0	LCD Segment corresponding to COM1 and COM3 are ON.
1	0	1	0	1	LCD Segment corresponding to COM1, COM3 and COM5 are ON.
1	0	1	1	0	LCD Segment corresponding to COM1, COM3 and COM4 are ON.
1	0	1	1	1	LCD Segment corresponding to COM1, COM3, COM4 and COM5 are ON.
1	1	0	0	0	LCD Segment corresponding to COM1 and COM2 are ON.
1	1	0	0	1	LCD Segment corresponding to COM1, COM2 and COM5 are ON.
1	1	0	1	0	LCD Segment corresponding to COM1, COM2 and COM4 are ON.
1	1	0	1	1	LCD Segment corresponding to COM1, COM2, COM4 and COM5 are ON.
1	1	1	0	0	LCD Segment corresponding to COM1, COM2 and COM3 are ON.
1	1	1	0	1	LCD Segment corresponding to COM1, COM2, COM3 and COM5 are ON.
1	1	1	1	0	LCD Segment corresponding to COM1, COM2, COM3 and COM4 are ON.
1	1	1	1	1	LCD Segment corresponding to COM1, COM2, COM3, COM4 and COM5 are ON.

Display Data and Output Pin Correspondence – continued

2.1/5 Duty Slave

Output Pin ^(Note)	COM1	COM2	COM3	COM4	COM5
S1/P1/G1	D1	D2	D3	D4	D5
S2/P2/G2	D6	D7	D8	D9	D10
S3/P3/G3	D11	D12	D13	D14	D15
S4/P4/G4	D16	D17	D18	D19	D20
S5/P5/G5	D21	D22	D23	D24	D25
S6/P6/G6	D26	D27	D28	D29	D30
S7/P7/G7	D31	D32	D33	D34	D35
S8/P8/G8	D36	D37	D38	D39	D40
S9/P9/G9	D41	D42	D43	D44	D45
S10	D46	D47	D48	D49	D50
S11	D51	D52	D53	D54	D55
S12	D56	D57	D58	D59	D60
S13	D61	D62	D63	D64	D65
S14	D66	D67	D68	D69	D70
S15	D71	D72	D73	D74	D75
S16	D76	D77	D78	D79	D80
S17	D81	D82	D83	D84	D85
S18	D86	D87	D88	D89	D90
S19	D91	D92	D93	D94	D95
S20	D96	D97	D98	D99	D100
S21	D101	D102	D103	D104	D105
S22	D106	D107	D108	D109	D110
S23	D111	D112	D113	D114	D115
S24	D116	D117	D118	D119	D120
S25	D121	D122	D123	D124	D125
S26	D126	D127	D128	D129	D130
S27	D131	D132	D133	D134	D135
S28	D136	D137	D138	D139	D140
S29	D141	D142	D143	D144	D145
S30	D146	D147	D148	D149	D150
S31	D151	D152	D153	D154	D155
S32	D156	D157	D158	D159	D160
S33	D161	D162	D163	D164	D165
S34	D166	D167	D168	D169	D170
S35	D171	D172	D173	D174	D175
S36	D176	D177	D178	D179	D180
S37	D181	D182	D183	D184	D185
S38	D186	D187	D188	D189	D190
S39	D191	D192	D193	D194	D195
S40	D196	D197	D198	D199	D200
S41	D201	D202	D203	D204	D205
S42	D206	D207	D208	D209	D210
S43	D211	D212	D213	D214	D215
S44	D216	D217	D218	D219	D220
S45	D221	D222	D223	D224	D225
S46	D226	D227	D228	D229	D230
S47	D231	D232	D233	D234	D235
S48	D236	D237	D238	D239	D240
S49	D241	D242	D243	D244	D245
S50	D246	D247	D248	D249	D250
S51	D251	D252	D253	D254	D255
S52	D256	D257	D258	D259	D260
S53	D261	D262	D263	D264	D265
S54	D266	D267	D268	D269	D270
S55	D271	D272	D273	D274	D275
S56	D276	D277	D278	D279	D280
S57	D281	D282	D283	D284	D285
S58	D286	D287	D288	D289	D290
S59	D291	D292	D293	D294	D295
S60	D296	D297	D298	D299	D300
S61	D301	D302	D303	D304	D305
S62	D306	D307	D308	D309	D310
S63	D311	D312	D313	D314	D315

Display Data and Output Pin Correspondence – continued

Output Pin ^(Note)	COM1	COM2	COM3	COM4	COM5
CLKIO/S64					
SYNCIO/S65					
S66/TESTIN	D316	D317	D318	D319	D320
COM5/S67	D321	D322	D323	D324	D325
COM4/S68	D326	D327	D328	D329	D330
COM3/S69	D331	D332	D333	D334	D335
COM2/S70	D336	D337	D338	D339	D340
COM1/S71	D341	D342	D343	D344	D345
S72	D346	D347	D348	D349	D350
OSC_IN/S73	D351	D352	D353	D354	D355

(Note) The Segment Output Pin function is assumed to be selected for the output pins – S1/P1/G1 to S9/P9/G9.
Also, CLKIO/S64 and SYNCIO/S65 pins are used as SYNC and CLK inputs.

To illustrate further, the states of the S21 output pin is given in the table below.

Display data					State of S21 Output Pin
D101	D102	D103	D104	D105	
0	0	0	0	0	LCD Segments corresponding to COM1 to COM5 are OFF.
0	0	0	0	1	LCD Segment corresponding to COM5 is ON.
0	0	0	1	0	LCD Segment corresponding to COM4 is ON.
0	0	0	1	1	LCD Segments corresponding to COM4 and COM5 are ON.
0	0	1	0	0	LCD Segment corresponding to COM3 is ON.
0	0	1	0	1	LCD Segments corresponding to COM3 and COM5 are ON.
0	0	1	1	0	LCD Segments corresponding to COM3 and COM4 are ON.
0	0	1	1	1	LCD Segments corresponding to COM3, COM4 and COM5 are ON.
0	1	0	0	0	LCD Segment corresponding to COM2 is ON.
0	1	0	0	1	LCD Segments corresponding to COM2 and COM5 are ON.
0	1	0	1	0	LCD Segments corresponding to COM2 and COM4 are ON.
0	1	0	1	1	LCD Segments corresponding to COM2, COM4 and COM5 are ON.
0	1	1	0	0	LCD Segments corresponding to COM2 and COM3 are ON.
0	1	1	0	1	LCD Segments corresponding to COM2, COM3, and COM5 are ON.
0	1	1	1	0	LCD Segments corresponding to COM2, COM3, and COM4 are ON.
0	1	1	1	1	LCD Segments corresponding to COM2, COM3, COM4 and COM5 are ON.
1	0	0	0	0	LCD Segment corresponding to COM1 is ON.
1	0	0	0	1	LCD Segment corresponding to COM1 and COM5 are ON.
1	0	0	1	0	LCD Segment corresponding to COM1 and COM4 are ON.
1	0	0	1	1	LCD Segment corresponding to COM1, COM4 and COM5 are ON.
1	0	1	0	0	LCD Segment corresponding to COM1 and COM3 are ON.
1	0	1	0	1	LCD Segment corresponding to COM1, COM3 and COM5 are ON.
1	0	1	1	0	LCD Segment corresponding to COM1, COM3 and COM4 are ON.
1	0	1	1	1	LCD Segment corresponding to COM1, COM3, COM4 and COM5 are ON.
1	1	0	0	0	LCD Segment corresponding to COM1 and COM2 are ON.
1	1	0	0	1	LCD Segment corresponding to COM1, COM2 and COM5 are ON.
1	1	0	1	0	LCD Segment corresponding to COM1, COM2 and COM4 are ON.
1	1	0	1	1	LCD Segment corresponding to COM1, COM2, COM4 and COM5 are ON.
1	1	1	0	0	LCD Segment corresponding to COM1, COM2 and COM3 are ON.
1	1	1	0	1	LCD Segment corresponding to COM1, COM2, COM3 and COM5 are ON.
1	1	1	1	0	LCD Segment corresponding to COM1, COM2, COM3 and COM4 are ON.
1	1	1	1	1	LCD Segment corresponding to COM1, COM2, COM3, COM4 and COM5 are ON.

Display Data and Output Pin Correspondence – continued

3.1/4 Duty Master

Output Pin ^(Note)	COM1	COM2	COM3	COM4
S1/P1/G1	D1	D2	D3	D4
S2/P2/G2	D5	D6	D7	D8
S3/P3/G3	D9	D10	D11	D12
S4/P4/G4	D13	D14	D15	D16
S5/P5/G5	D17	D18	D19	D20
S6/P6/G6	D21	D22	D23	D24
S7/P7/G7	D25	D26	D27	D28
S8/P8/G8	D29	D30	D31	D32
S9/P9/G9	D33	D34	D35	D36
S10	D37	D38	D39	D40
S11	D41	D42	D43	D44
S12	D45	D46	D47	D48
S13	D49	D50	D51	D52
S14	D53	D54	D55	D56
S15	D57	D58	D59	D60
S16	D61	D62	D63	D64
S17	D65	D66	D67	D68
S18	D69	D70	D71	D72
S19	D73	D74	D75	D76
S20	D77	D78	D79	D80
S21	D81	D82	D83	D84
S22	D85	D86	D87	D88
S23	D89	D90	D91	D92
S24	D93	D94	D95	D96
S25	D97	D98	D99	D100
S26	D101	D102	D103	D104
S27	D105	D106	D107	D108
S28	D109	D110	D111	D112
S29	D113	D114	D115	D116
S30	D117	D118	D119	D120
S31	D121	D122	D123	D124
S32	D125	D126	D127	D128
S33	D129	D130	D131	D132
S34	D133	D134	D135	D136
S35	D137	D138	D139	D140
S36	D141	D142	D143	D144
S37	D145	D146	D147	D148
S38	D149	D150	D151	D152
S39	D153	D154	D155	D156
S40	D157	D158	D159	D160
S41	D161	D162	D163	D164
S42	D165	D166	D167	D168
S43	D169	D170	D171	D172
S44	D173	D174	D175	D176
S45	D177	D178	D179	D180
S46	D181	D182	D183	D184
S47	D185	D186	D187	D188
S48	D189	D190	D191	D192
S49	D193	D194	D195	D196
S50	D197	D198	D199	D200
S51	D201	D202	D203	D204
S52	D205	D206	D207	D208
KS1/S53	D209	D210	D211	D212
KS2/S54	D213	D214	D215	D216
KS3/S55	D217	D218	D219	D220
KS4/S56	D221	D222	D223	D224
KS5/S57	D225	D226	D227	D228
KS6/S58	D229	D230	D231	D232
KI1/S59	D233	D234	D235	D236
KI2/S60	D237	D238	D239	D240
KI3/S61	D241	D242	D243	D244
KI4/S62	D245	D246	D247	D248
KI5/S63	D249	D250	D251	D252

Display Data and Output Pin Correspondence – continued

Output Pin ^(Note)	COM1	COM2	COM3	COM4
CLKIO/S64	D253	D254	D255	D256
SYNCIO/S65	D257	D258	D259	D260
S66/TESTIN				
COM5/S67	D261	D262	D263	D264
COM4/S68				
COM3/S69				
COM2/S70				
COM1/S71				
S72	D265	D266	D267	D268
OSC_IN/S73	D269	D270	D271	D272

(Note) The Segment Output Pin function is assumed to be selected for the output pins – S1/P1/G1 to S9/P9/G9, KS1/S53 to KS6/S58, K11/S59 to K15/S63, OSC_IN/S73.

During 1 chip mode, S66/TESTIN functions as TESTIN input.

During 2 chip mode(Master with Slave), CLKIO/S64 and SYNCIO/S65 function as CLK and SYNC outputs.

To illustrate further, the states of the S21 output pin is given in the table below.

Display data				State of S21 Output Pin
D81	D82	D83	D84	
0	0	0	0	LCD Segments corresponding to COM1 to COM4 are OFF.
0	0	0	1	LCD Segment corresponding to COM4 is ON.
0	0	1	0	LCD Segment corresponding to COM3 is ON.
0	0	1	1	LCD Segments corresponding to COM3 and COM4 are ON.
0	1	0	0	LCD Segment corresponding to COM2 is ON.
0	1	0	1	LCD Segments corresponding to COM2 and COM4 are ON.
0	1	1	0	LCD Segments corresponding to COM2 and COM3 are ON.
0	1	1	1	LCD Segments corresponding to COM2, COM3 and COM4 are ON.
1	0	0	0	LCD Segment corresponding to COM1 is ON.
1	0	0	1	LCD Segments corresponding to COM1 and COM4 are ON.
1	0	1	0	LCD Segments corresponding to COM1 and COM3 are ON.
1	0	1	1	LCD Segments corresponding to COM1, COM3 and COM4 are ON.
1	1	0	0	LCD Segments corresponding to COM1 and COM2 are ON.
1	1	0	1	LCD Segments corresponding to COM1, COM2, and COM4 are ON.
1	1	1	0	LCD Segments corresponding to COM1, COM2, and COM3 are ON.
1	1	1	1	LCD Segments corresponding to COM1, COM2, COM3 and COM4 are ON.

Display Data and Output Pin Correspondence – continued

4.1/4 Duty Slave

Output Pin ^(Note)	COM1	COM2	COM3	COM4
S1/P1/G1	D1	D2	D3	D4
S2/P2/G2	D5	D6	D7	D8
S3/P3/G3	D9	D10	D11	D12
S4/P4/G4	D13	D14	D15	D16
S5/P5/G5	D17	D18	D19	D20
S6/P6/G6	D21	D22	D23	D24
S7/P7/G7	D25	D26	D27	D28
S8/P8/G8	D29	D30	D31	D32
S9/P9/G9	D33	D34	D35	D36
S10	D37	D38	D39	D40
S11	D41	D42	D43	D44
S12	D45	D46	D47	D48
S13	D49	D50	D51	D52
S14	D53	D54	D55	D56
S15	D57	D58	D59	D60
S16	D61	D62	D63	D64
S17	D65	D66	D67	D68
S18	D69	D70	D71	D72
S19	D73	D74	D75	D76
S20	D77	D78	D79	D80
S21	D81	D82	D83	D84
S22	D85	D86	D87	D88
S23	D89	D90	D91	D92
S24	D93	D94	D95	D96
S25	D97	D98	D99	D100
S26	D101	D102	D103	D104
S27	D105	D106	D107	D108
S28	D109	D110	D111	D112
S29	D113	D114	D115	D116
S30	D117	D118	D119	D120
S31	D121	D122	D123	D124
S32	D125	D126	D127	D128
S33	D129	D130	D131	D132
S34	D133	D134	D135	D136
S35	D137	D138	D139	D140
S36	D141	D142	D143	D144
S37	D145	D146	D147	D148
S38	D149	D150	D151	D152
S39	D153	D154	D155	D156
S40	D157	D158	D159	D160
S41	D161	D162	D163	D164
S42	D165	D166	D167	D168
S43	D169	D170	D171	D172
S44	D173	D174	D175	D176
S45	D177	D178	D179	D180
S46	D181	D182	D183	D184
S47	D185	D186	D187	D188
S48	D189	D190	D191	D192
S49	D193	D194	D195	D196
S50	D197	D198	D199	D200
S51	D201	D202	D203	D204
S52	D205	D206	D207	D208
S53	D209	D210	D211	D212
S54	D213	D214	D215	D216
S55	D217	D218	D219	D220
S56	D221	D222	D223	D224
S57	D225	D226	D227	D228
S58	D229	D230	D231	D232
S59	D233	D234	D235	D236
S60	D237	D238	D239	D240
S61	D241	D242	D243	D244
S62	D245	D246	D247	D248
S63	D249	D250	D251	D252

Display Data and Output Pin Correspondence – continued

Output Pin ^(Note)	COM1	COM2	COM3	COM4
CLKIO/S64				
SYNCIO/S65				
S66/TESTIN	D253	D254	D255	D256
COM5/S67	D257	D258	D259	D260
COM4/S68	D261	D262	D263	D264
COM3/S69	D265	D266	D267	D268
COM2/S70	D269	D270	D271	D272
COM1/S71	D273	D274	D275	D276
S72	D277	D278	D279	D280
OSC_IN/S73	D281	D282	D283	D284

(Note) The Segment Output Pin function is assumed to be selected for the output pins – S1/P1/G1 to S9/P9/G9.
Also, CLKIO/S64 and SYNCIO/S65 pins are used as SYNC and CLK inputs.

To illustrate further, the states of the S21 output pin is given in the table below.

Display data				State of S21 Output Pin
D81	D82	D83	D84	
0	0	0	0	LCD Segments corresponding to COM1 to COM4 are OFF.
0	0	0	1	LCD Segment corresponding to COM4 is ON.
0	0	1	0	LCD Segment corresponding to COM3 is ON.
0	0	1	1	LCD Segments corresponding to COM3 and COM4 are ON.
0	1	0	0	LCD Segment corresponding to COM2 is ON.
0	1	0	1	LCD Segments corresponding to COM2 and COM4 are ON.
0	1	1	0	LCD Segments corresponding to COM2 and COM3 are ON.
0	1	1	1	LCD Segments corresponding to COM2, COM3 and COM4 are ON.
1	0	0	0	LCD Segment corresponding to COM1 is ON.
1	0	0	1	LCD Segments corresponding to COM1 and COM4 are ON.
1	0	1	0	LCD Segments corresponding to COM1 and COM3 are ON.
1	0	1	1	LCD Segments corresponding to COM1, COM3 and COM4 are ON.
1	1	0	0	LCD Segments corresponding to COM1 and COM2 are ON.
1	1	0	1	LCD Segments corresponding to COM1, COM2, and COM4 are ON.
1	1	1	0	LCD Segments corresponding to COM1, COM2, and COM3 are ON.
1	1	1	1	LCD Segments corresponding to COM1, COM2, COM3 and COM4 are ON.

Display Data and Output Pin Correspondence – continued

5. 1/3 duty Master

Output Pin ^(Note)	COM1	COM2	COM3
S1/P1/G1	D1	D2	D3
S2/P2/G2	D4	D5	D6
S3/P3/G3	D7	D8	D9
S4/P4/G4	D10	D11	D12
S5/P5/G5	D13	D14	D15
S6/P6/G6	D16	D17	D18
S7/P7/G7	D19	D20	D21
S8/P8/G8	D22	D23	D24
S9/P9/G9	D25	D26	D27
S10	D28	D29	D30
S11	D31	D32	D33
S12	D34	D35	D36
S13	D37	D38	D39
S14	D40	D41	D42
S15	D43	D44	D45
S16	D46	D47	D48
S17	D49	D50	D51
S18	D52	D53	D54
S19	D55	D56	D57
S20	D58	D59	D60
S21	D61	D62	D63
S22	D64	D65	D66
S23	D67	D68	D69
S24	D70	D71	D72
S25	D73	D74	D75
S26	D76	D77	D78
S27	D79	D80	D81
S28	D82	D83	D84
S29	D85	D85	D87
S30	D88	D89	D90
S31	D91	D92	D93
S32	D94	D95	D96
S33	D97	D98	D99
S34	D100	D101	D102
S35	D103	D104	D105
S36	D106	D107	D108
S37	D109	D110	D111
S38	D112	D113	D114
S39	D115	D116	D117
S40	D118	D119	D120
S41	D121	D122	D123
S42	D124	D125	D126
S43	D127	D128	D129
S44	D130	D131	D132
S45	D133	D134	D135
S46	D136	D137	D138
S47	D139	D140	D141
S48	D142	D143	D144
S49	D145	D146	D147
S50	D148	D149	D150
S51	D151	D152	D153
S52	D154	D155	D156
KS1/S53	D157	D158	D159
KS2/S54	D160	D161	D162
KS3/S55	D163	D164	D165
KS4/S56	D166	D167	D168
KS5/S57	D169	D170	D171
KS6/S58	D172	D173	D174
KI1/S59	D175	D176	D177
KI2/S60	D178	D179	D180
KI3/S61	D181	D182	D183
KI4/S62	D184	D185	D186
KI5/S63	D187	D188	D189

Display Data and Output Pin Correspondence – continued

Output Pin ^(Note)	COM1	COM2	COM3
CLKIO/S64	D190	D191	D192
SYNCIO/S65	D193	D194	D195
S66/TESTIN			
COM5/S67	D196	D197	D198
COM4/S68			
COM3/S69			
COM2/S70			
COM1/S71			
S72	D199	D200	D201
OSC_IN/S73	D202	D203	D204

(Note) The Segment Output Pin function is assumed to be selected for the output pins – S1/P1/G1 to S9/P9/G9, KS1/S53 to KS6/S58, KI1/S59 to KI5/S63, OSC_IN/S73.

During 1 chip mode, S66/TESTIN functions as TESTIN input.

During 2 chip mode (Master with Slave), CLKIO/S64 and SYNCIO/S65 function as CLK and SYNC outputs.

To illustrate further, the states of the S21 output pin is given in the table below.

Display data			State of S21 Output Pin
D61	D62	D63	
0	0	0	LCD Segments corresponding to COM1 to COM3 are OFF.
0	0	1	LCD Segment corresponding to COM3 is ON.
0	1	0	LCD Segment corresponding to COM2 is ON.
0	1	1	LCD Segments corresponding to COM2 and COM3 are ON.
1	0	0	LCD Segment corresponding to COM1 is ON.
1	0	1	LCD Segments corresponding to COM1 and COM3 are ON.
1	1	0	LCD Segments corresponding to COM1 and COM2 are ON.
1	1	1	LCD Segments corresponding to COM1, COM2 and COM3 are ON.

Display Data and Output Pin Correspondence – continued

6.1/3 Duty Slave

Output Pin ^(Note)	COM1	COM2	COM3
S1/P1/G1	D1	D2	D3
S2/P2/G2	D4	D5	D6
S3/P3/G3	D7	D8	D9
S4/P4/G4	D10	D11	D12
S5/P5/G5	D13	D14	D15
S6/P6/G6	D16	D17	D18
S7/P7/G7	D19	D20	D21
S8/P8/G8	D22	D23	D24
S9/P9/G9	D25	D26	D27
S10	D28	D29	D30
S11	D31	D32	D33
S12	D34	D35	D36
S13	D37	D38	D39
S14	D40	D41	D42
S15	D43	D44	D45
S16	D46	D47	D48
S17	D49	D50	D51
S18	D52	D53	D54
S19	D55	D56	D57
S20	D58	D59	D60
S21	D61	D62	D63
S22	D64	D65	D66
S23	D67	D68	D69
S24	D70	D71	D72
S25	D73	D74	D75
S26	D76	D77	D78
S27	D79	D80	D81
S28	D82	D83	D84
S29	D85	D85	D87
S30	D88	D89	D90
S31	D91	D92	D93
S32	D94	D95	D96
S33	D97	D98	D99
S34	D100	D101	D102
S35	D103	D104	D105
S36	D106	D107	D108
S37	D109	D110	D111
S38	D112	D113	D114
S39	D115	D116	D117
S40	D118	D119	D120
S41	D121	D122	D123
S42	D124	D125	D126
S43	D127	D128	D129
S44	D130	D131	D132
S45	D133	D134	D135
S46	D136	D137	D138
S47	D139	D140	D141
S48	D142	D143	D144
S49	D145	D146	D147
S50	D148	D149	D150
S51	D151	D152	D153
S52	D154	D155	D156
S53	D157	D158	D159
S54	D160	D161	D162
S55	D163	D164	D165
S56	D166	D167	D168
S57	D169	D170	D171
S58	D172	D173	D174
S59	D175	D176	D177
S60	D178	D179	D180
S61	D181	D182	D183
S62	D184	D185	D186
S63	D187	D188	D189

Display Data and Output Pin Correspondence – continued

Output Pin ^(Note)	COM1	COM2	COM3
CLKIO/S64			
SYNCIO/S65			
S66/TESTIN	D190	D191	D192
COM5/S67	D193	D194	D195
COM4/S68	D196	D197	D198
COM3/S69	D199	D200	D201
COM2/S70	D202	D203	D204
COM1/S71	D205	D206	D207
S72	D208	D209	D210
OSC/S73	D211	D212	D213

(Note) The Segment Output Pin function is assumed to be selected for the output pins – S1/P1/G1 to S9/P9/G9.
Also, CLKIO/S64 and SYNCIO/S65 pins are used as SYNC and CLK inputs.

To illustrate further, the states of the S21 output pin is given in the table below.

Display data			State of S21 Output Pin
D61	D62	D63	
0	0	0	LCD Segments corresponding to COM1 to COM3 are OFF.
0	0	1	LCD Segment corresponding to COM3 is ON.
0	1	0	LCD Segment corresponding to COM2 is ON.
0	1	1	LCD Segments corresponding to COM2 and COM3 are ON.
1	0	0	LCD Segment corresponding to COM1 is ON.
1	0	1	LCD Segments corresponding to COM1 and COM3 are ON.
1	1	0	LCD Segments corresponding to COM1 and COM2 are ON.
1	1	1	LCD Segments corresponding to COM1, COM2 and COM3 are ON.

Display Data and Output Pin Correspondence – continued

7. Static Master

Output Pin ^(Note)	COM1
S1/P1/G1	D1
S2/P2/G2	D2
S3/P3/G3	D3
S4/P4/G4	D4
S5/P5/G5	D5
S6/P6/G6	D6
S7/P7/G7	D7
S8/P8/G8	D8
S9/P9/G9	D9
S10	D10
S11	D11
S12	D12
S13	D13
S14	D14
S15	D15
S16	D16
S17	D17
S18	D18
S19	D19
S20	D20
S21	D21
S22	D22
S23	D23
S24	D24
S25	D25
S26	D26
S27	D27
S28	D28
S29	D29
S30	D30
S31	D31
S32	D32
S33	D33
S34	D34
S35	D35
S36	D36
S37	D37
S38	D38
S39	D39
S40	D40
S41	D41
S42	D42
S43	D43
S44	D44
S45	D45
S46	D46
S47	D47
S48	D48
S49	D49
S50	D50
S51	D51
S52	D52
KS1/S53	D53
KS2/S54	D54
KS3/S55	D55
KS4/S56	D56
KS5/S57	D57
KS6/S58	D58
KI1/S59	D59
KI2/S60	D60
KI3/S61	D61
KI4/S62	D62
KI5/S63	D63

Display Data and Output Pin Correspondence – continued

Output Pin ^(Note)	COM1
CLKIO/S64	D64
SYNCIO/S65	D65
S66/TESTIN	
COM5/S67	D66
COM4/S68	
COM3/S69	
COM2/S70	
COM1/S71	
S72	D67
OSC_IN/S73	D68

(Note) The Segment Output Pin function is assumed to be selected for the output pins – S1/P1/G1 to S9/P9/G9, KS1/S53 to KS6/S58, KI1/S59 to KI5/S63, OSC_IN/S73.
 During 1 chip mode, S66/TESTIN functions as TESTIN input.
 During 2 chip mode (Master with Slave), CLKIO/S64 and SYNCIO/S65 function as CLK and SYNC outputs.

To illustrate further, the states of the S21 output pin is given in the table below.

Display Data	State of S21 Output Pin
D21	
0	LCD Segment corresponding to COM1 is OFF.
1	LCD Segment corresponding to COM1 is ON.

Display Data and Output Pin Correspondence – continued

8. Static Slave

Output Pin ^(Note)	COM1
S1/P1/G1	D1
S2/P2/G2	D2
S3/P3/G3	D3
S4/P4/G4	D4
S5/P5/G5	D5
S6/P6/G6	D6
S7/P7/G7	D7
S8/P8/G8	D8
S9/P9/G9	D9
S10	D10
S11	D11
S12	D12
S13	D13
S14	D14
S15	D15
S16	D16
S17	D17
S18	D18
S19	D19
S20	D20
S21	D21
S22	D22
S23	D23
S24	D24
S25	D25
S26	D26
S27	D27
S28	D28
S29	D29
S30	D30
S31	D31
S32	D32
S33	D33
S34	D34
S35	D35
S36	D36
S37	D37
S38	D38
S39	D39
S40	D40
S41	D41
S42	D42
S43	D43
S44	D44
S45	D45
S46	D46
S47	D47
S48	D48
S49	D49
S50	D50
S51	D51
S52	D52
S53	D53
S54	D54
S55	D55
S56	D56
S57	D57
S58	D58
S59	D59
S60	D60
S61	D61
S62	D62
S63	D63

Display Data and Output Pin Correspondence – continued

Output Pin ^(Note)	COM1
CLKIO/S64	
SYNCIO/S65	
S66/TESTIN	D64
COM5/S67	D65
COM4/S68	D66
COM3/S69	D67
COM2/S70	D68
COM1/S71	D69
S72	D70
OSC_IN/S73	D71

(Note) The Segment Output Pin function is assumed to be selected for the output pins – S1/P1/G1 to S9/P9/G9.
Also, CLKIO/S64 and SYNCIO/S65 pins are used as SYNC and CLK inputs.

To illustrate further, the states of the S21 output pin is given in the table below.

Display Data	State of S21Output Pin
D21	
0	LCD Segment corresponding to COM1 is OFF.
1	LCD Segment corresponding to COM1 is ON.

Serial Data Output

1. When SCL is stopped at the low level^(Note 1)

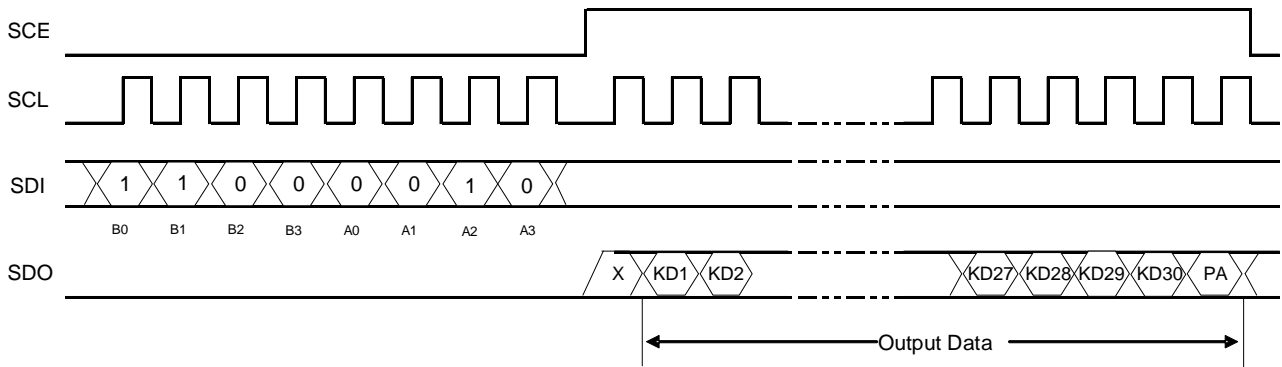

Figure 15. Serial Data Output Format

(Note 1)

- 1. X = Don't care
- 2. B0 to B3, A0 to A3: Serial Interface address

2. When SCL is stopped at the high level^(Note 2)

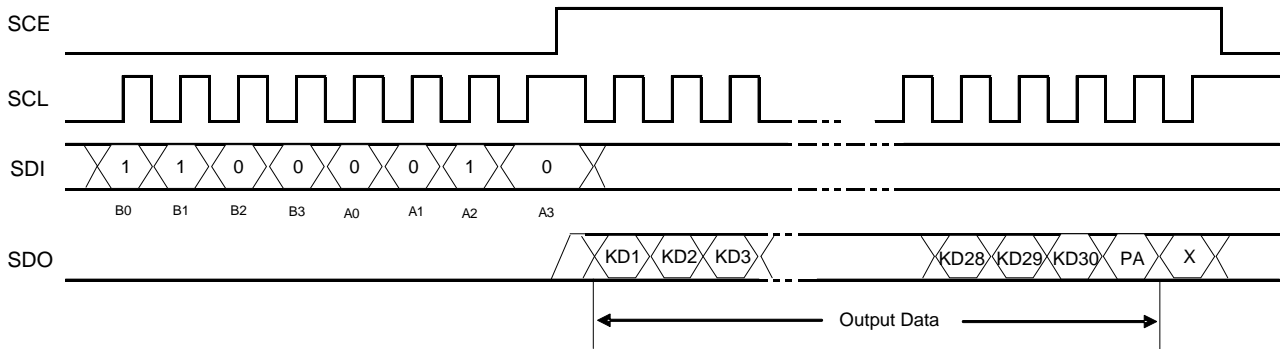

Figure 16. Serial Data Output Format

(Note 2)

- 1. X = Don't care
- 2. B0 to B3, A0 to A3: Serial Interface address
- 3. Serial Interface address: 43H
- 4. KD1 to KD30: Key data
- 5. PA: Power-saving acknowledge data
- 6. If a key data read operation is executed when SDO is high, the read key data (KD1 to KD30) and Power-saving acknowledge data (PA) will be invalid.

Output Data

1.KD1 TO KD30: KEY DATA

When a key matrix of up to 30 keys is formed from the KS1 to KS6 output pins and the KI1 to KI5 input pins and one of those keys are pressed, the key output data corresponding to that key will be set to 1. The table shows the relationship between those pins and the key data bits.

Item	KI1	KI2	KI3	KI4	KI5
KS1	KD1	KD2	KD3	KD4	KD5
KS2	KD6	KD7	KD8	KD9	KD10
KS3	KD11	KD12	KD13	KD14	KD15
KS4	KD16	KD17	KD18	KD19	KD20
KS5	KD21	KD22	KD23	KD24	KD25
KS6	KD26	KD27	KD28	KD29	KD30

2.PA: Power-saving Acknowledge Data

This output data is set to the state when the key is pressed. In that case SDO will go to the low level. If serial data is input during this period and the mode is set (normal mode or power-saving mode), the IC will be set to that mode.

PA is set to 1 in the power-saving mode and to 0 in the normal mode.

Power-saving Mode

Power-saving mode is set up by setting at least one of control data BU0, BU1 or BU2 set to 1. The segment outputs will all go low and the common outputs will also go low, and the oscillator on the OSC pin will stop (it will be started by a key press). This reduces power consumption. This mode is cleared by sending control data with all the BU0 BU1 and BU2 set to 0. However, note that the S1/P1/G1 to S9/P9/G9 outputs can be used as General-purpose output pins according to the state of the P0 to P3 control data bits, even in power-saving mode. (See the [Control Data Functions](#).)

Key Scan Operation Functions

1.Key Scan Timing

The key scan period is 4608T(s). To reliably determine the on/off state of the keys, the BU97540KV-M scans the keys twice and determines that a key has been pressed when the key data agrees. It outputs a key data read request (a low level on SDO) 9840T(s) after starting a key scan. If the key data does not agree and a key was pressed at that point, it scans the keys again. Thus the BU97540KV-M cannot detect a key press shorter than 9840T(s).

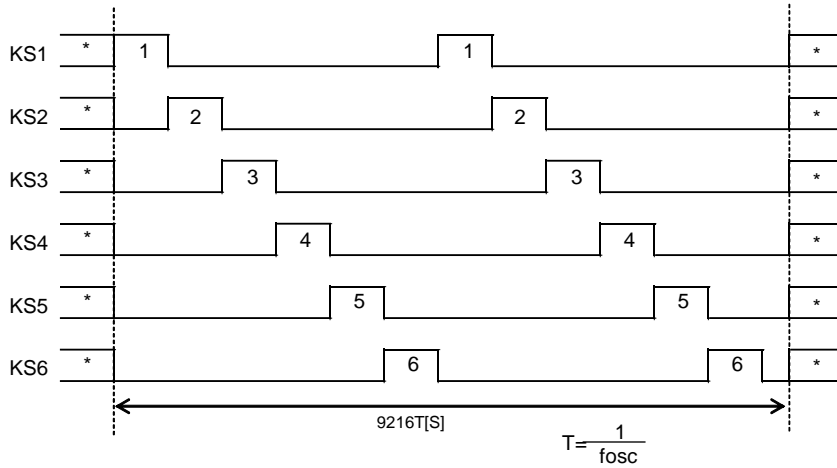

Figure 17. Key Scan Timing^(Note)

(Note) In power-saving mode, the high/low state of these pins is determined by the BU0 to BU2 bits in the control data. Key scan output signals are not output from pins that are set "L".

2.In Normal Mode

The pins KS1 to KS6 are set "H".

When a key is pressed a key scan is started and the keys are scanned until all keys are released. Multiple key presses are recognized by determining whether multiple key data bits are set.

If a key is pressed for longer than 9840T(s) (Where $T = 1/f_{osc}$) the BU97540KV-M outputs a key data read request (a low level on SDO) to the controller. The controller acknowledges this request and reads the key data. However, if SCE is high during a serial data transfer, SDO will be set high.

After the controller reads the key data, the key data read request is cleared (SDO is set high) and the BU97540KV-M performs another key scan. Also note that SDO, being an open-drain output, requires a pull-up resistor (between 1 kΩ and 10kΩ).

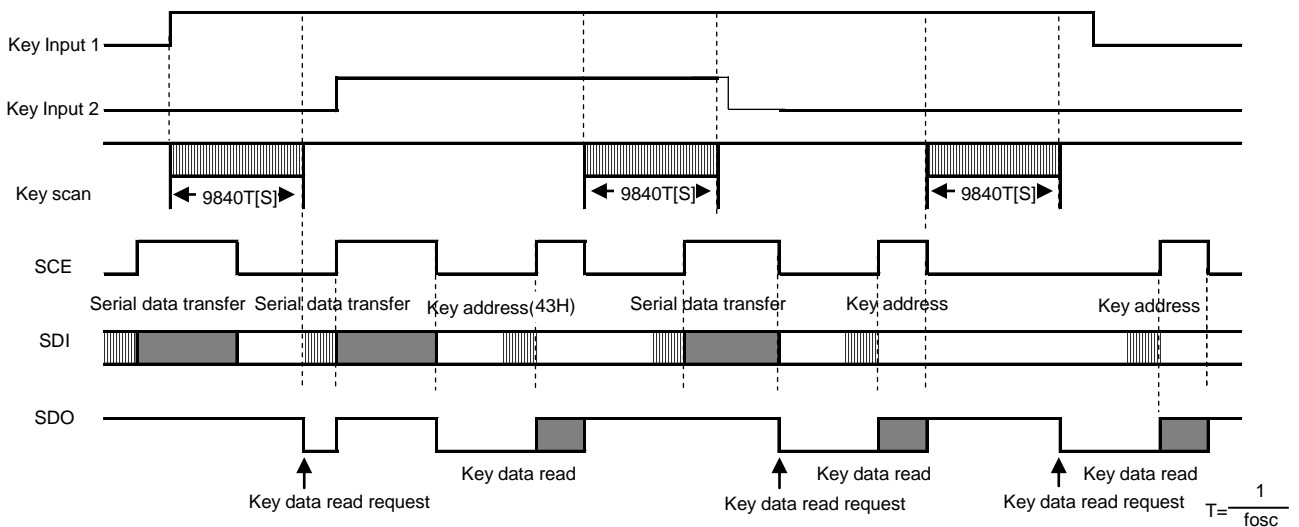

Figure 18. Key scan operation in normal mode

Key Scan Operation Functions – continued

3. In Power-saving Mode

The pins KS1 to KS6 are set to high or low by the BU0 to BU2 bits in the control data. (See the Control Data Functions for details.)

If a key on one of the lines corresponding to a KS1 to KS6 pin which is set high is pressed, the oscillator on the OSC pin is started and a key scan is performed. Keys are scanned until all keys are released. Multiple key presses are recognized by determining whether multiple key data bits are set.

If a key is pressed for 9840T(s) (Where $T = 1 / f_{osc}$) or more the BU97540KV-M outputs a key data read request (a low level on SDO) to the controller. The controller acknowledges this request and reads the key data. However, if SCE is high during a serial data transfer, SDO will be set high.

After the controller reads the key data, the key data read request is cleared (SDO is set high) and the BU97540KV-M performs another key scan. However, this does not clear sleep mode. Also note that SDO, being an open-drain output, requires a pull-up resistor (between 1kΩ and 10kΩ).

Power-saving mode key scan example

Example: BU0 = 0, BU1 = 0, BU2 = 1 (Only KS6 high level output)

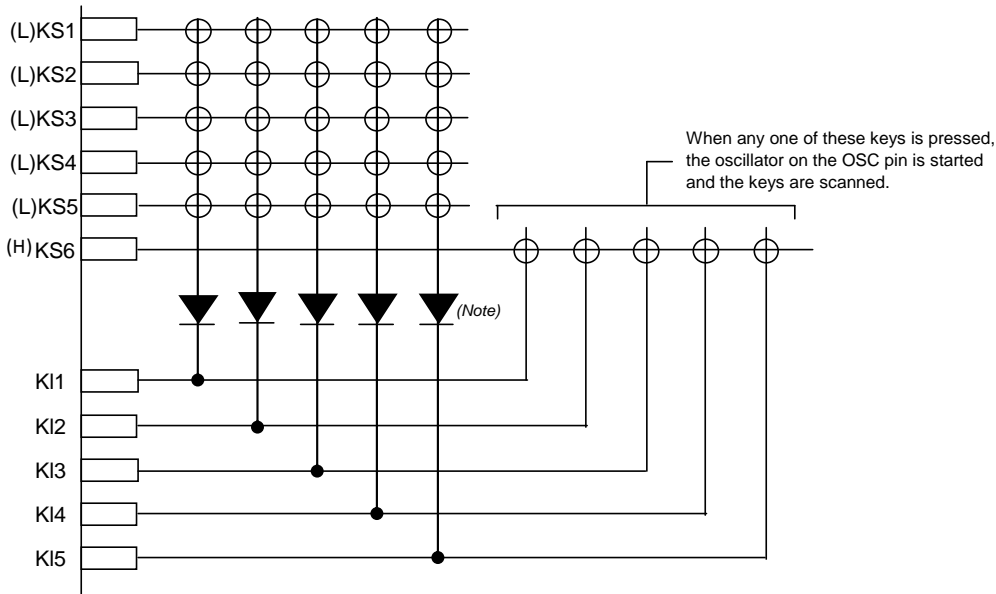

(Note)

These diodes are required to reliably recognize multiple key presses on the KS6 line when power-saving mode state with only KS6 high, as in the above example. That is, these diodes prevent incorrect operations due to sneak currents in the KS6 key scan output signal when keys on the KS1 to KS5 lines are pressed at the same time.

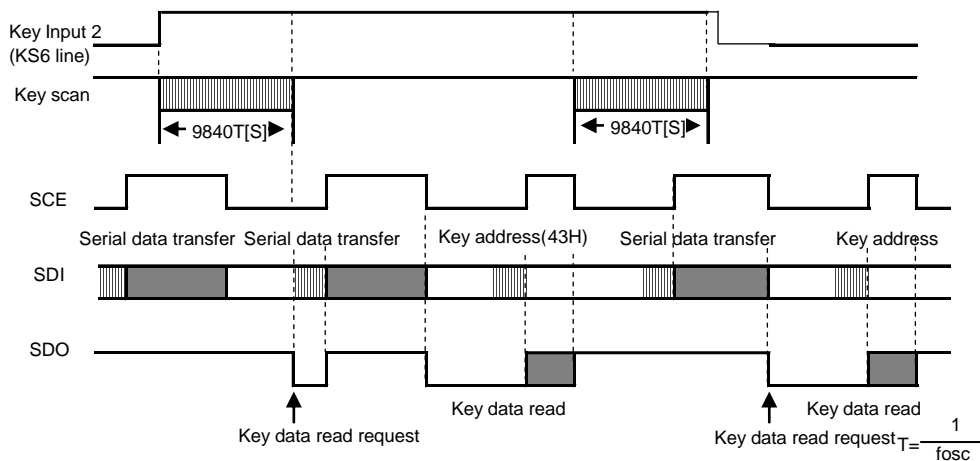

Figure 19. Key scan operation in Power-saving mode

Multiple Key Presses

Although the BU97540KV-M is capable of key scanning without inserting diodes for dual key presses, triple key presses on the KI1 to KI5 input pin lines, or multiple key presses on the KS1 to KS6 output pin lines, multiple presses other than these cases may result in keys that were not pressed recognized as having been pressed. Therefore, a diode must be inserted in series with each key. Applications that do not recognize multiple key presses of three or more keys should check the key data for three or more 1 bit and ignore such data.

Controller Key Data Read Techniques

When the controller receives a key data read request from BU97540KV-M, it performs a key data read acquisition operation using either the Timer Based Key Data Acquisition or the Interrupt Based Key Data Acquisition.

Timer Based Key Data Acquisition Technique

Under the Timer Based Key Data Acquisition Technique, the controller uses a timer to determine the states of the keys (on or off) and read the key data. Please refer to the flowchart below.

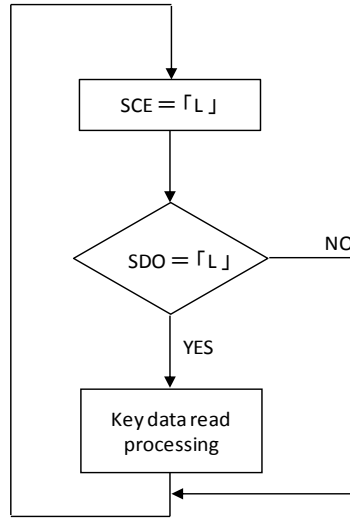

Key data read processing: Refer to [“Serial Data Output”](#)

Figure 20. Flowchart

In this technique, the controller uses a timer to determine key on/off states and read the key data. The controller must check the SDO state when SCE is low every t_7 period without fail. If SDO is low, the controller recognizes that a key has been pressed and executes the key data read operation.

The period t_7 in this technique must satisfy the following condition.
 $t_7 > t_4 + t_5 + t_6$

If a key data read operation is executed when SDO is high, the read key data (KD1 to KD30) and power-saving acknowledge data (PA) will be invalid.

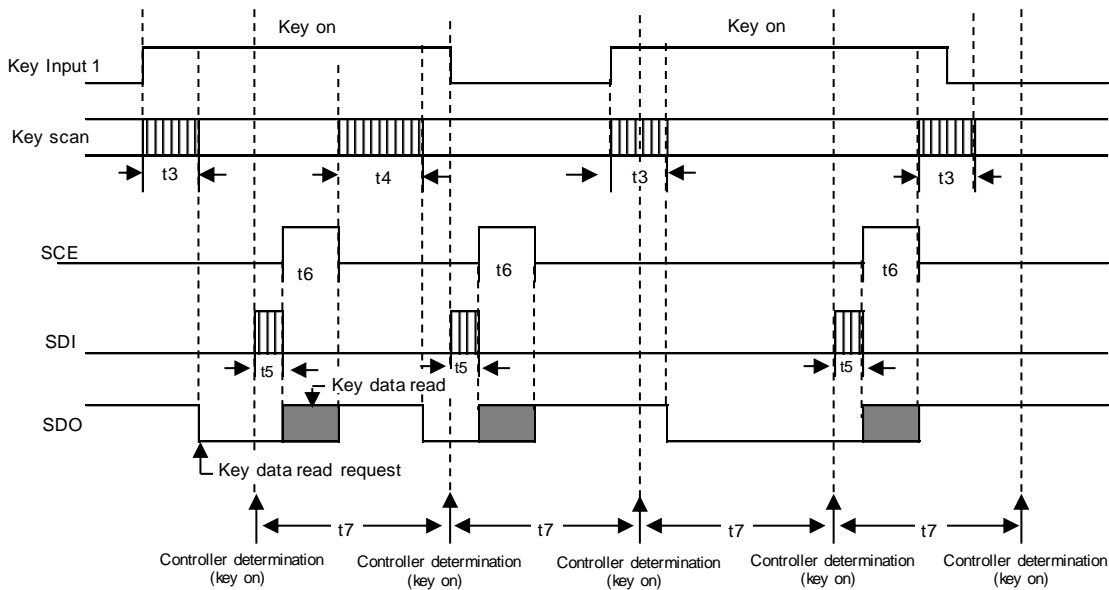

- t_3 : Key scan execution time when the key data agreed for two key scans. (9840T[s])
- t_4 : Key scan execution time when the key data did not agree for two key scans and the key scan was executed again. (19680T[s])
- t_5 : Key address (43H) transfer time
- t_6 : Key data read time

Figure 21. Timer based key data read operation

Interrupt Based Key Data Acquisition Technique

Under the Interrupt Based Key Data Acquisition Technique, the controller uses interrupts to determine the state of the keys (on or off) and read the key data. Please refer to the flow chart diagram below.

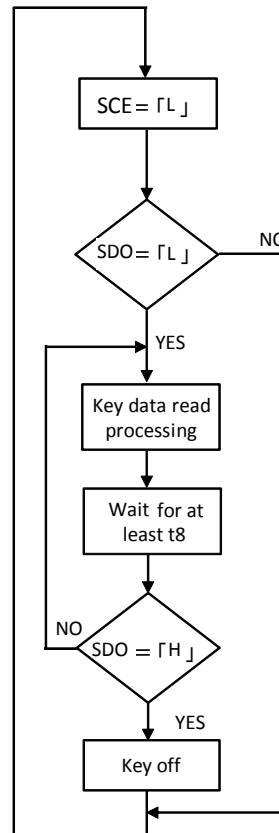

Key data read processing: Refer to [“Serial Data Output”](#)

Figure 22. Flowchart

Interrupt Based Key Data Acquisition Technique – continued

In this technique, the controller uses interrupts to determine key on/off states and read the key data. The controller must check the SDO state when SCE is low. If SDO is low, the controller recognizes that a key has been pressed and executes the key data read operation. After that the next key on/off determination is performed after the time t_8 has elapsed by checking the SDO state when SCE is low and reading the key data. The period t_8 in this technique must satisfy $t_8 > t_4$.

If a key data read operation is executed when SDO is high, the read key data (KD1 to KD30) and power-saving acknowledge data (PA) will be invalid.

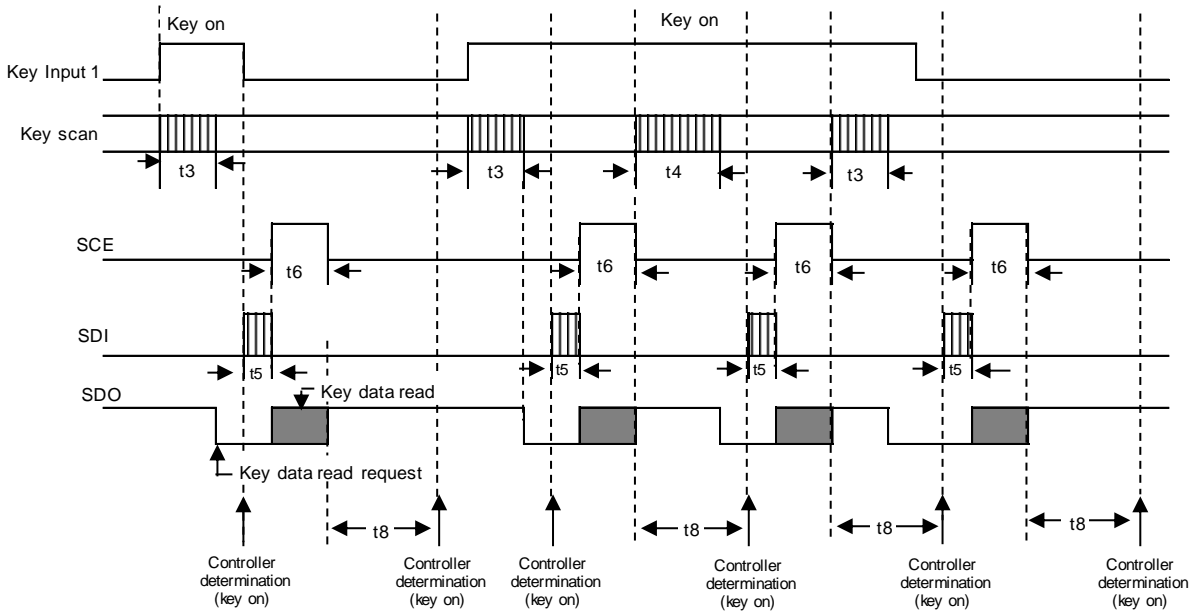

- t3: Key scan execution time when the key data agreed for two key scans. (9840T[s])
- t4: Key scan execution time when the key data did not agree for two key scans and the key scan was executed again. (19680T[s])
- t5: Key address (43H) transfer time
- t6: Key data read time

Figure 23. Interrupt Based Key Data Read Operation

LCD Driving Waveforms

1. Line Inversion 1/5 Duty 1/3 Bias Drive Scheme

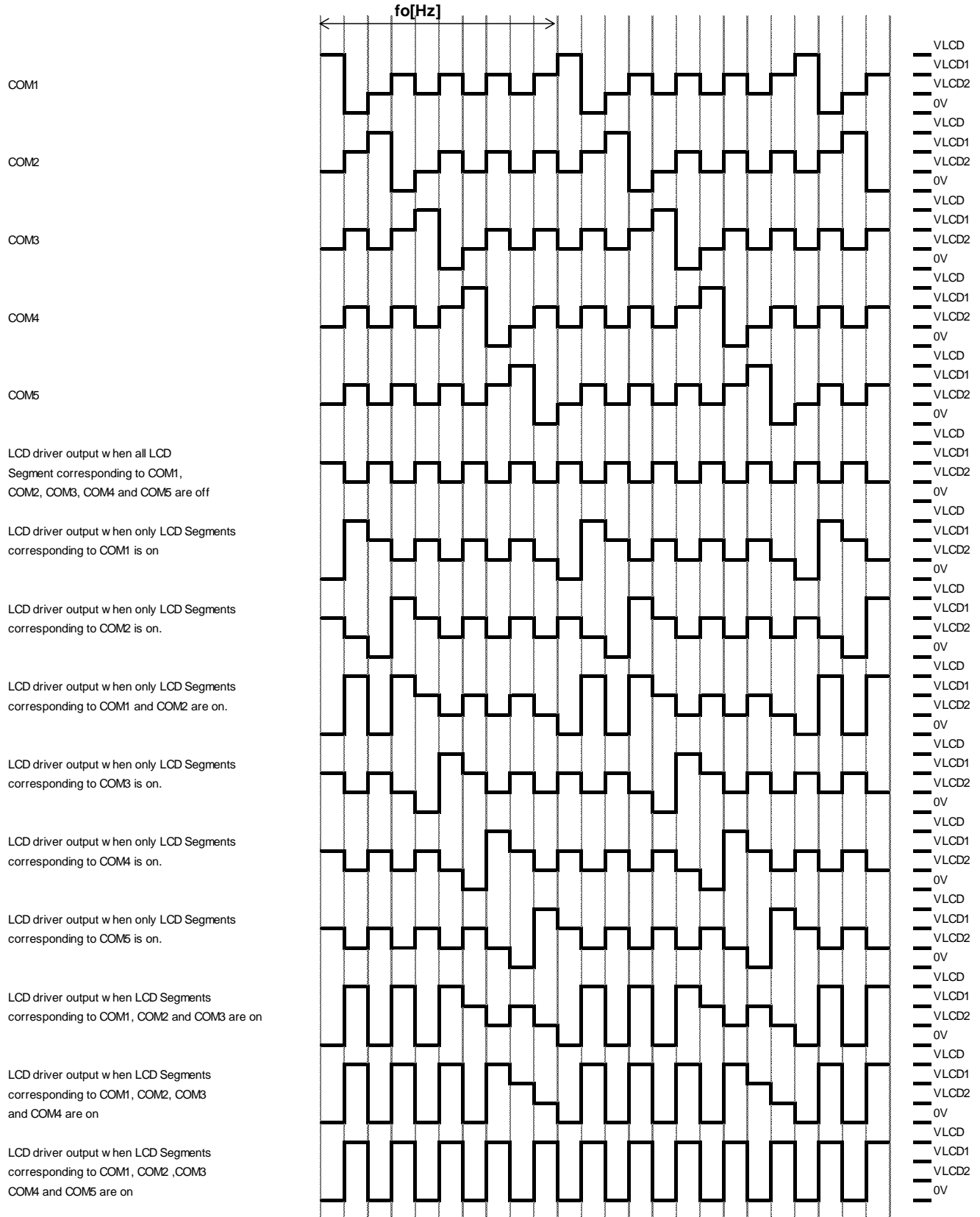

Figure 24. LCD Waveform (Line Inversion, 1/5 Duty, 1/3 Bias)

LCD Driving Waveforms – continued

3. Line Inversion 1/4 Duty 1/3 Bias Drive Scheme

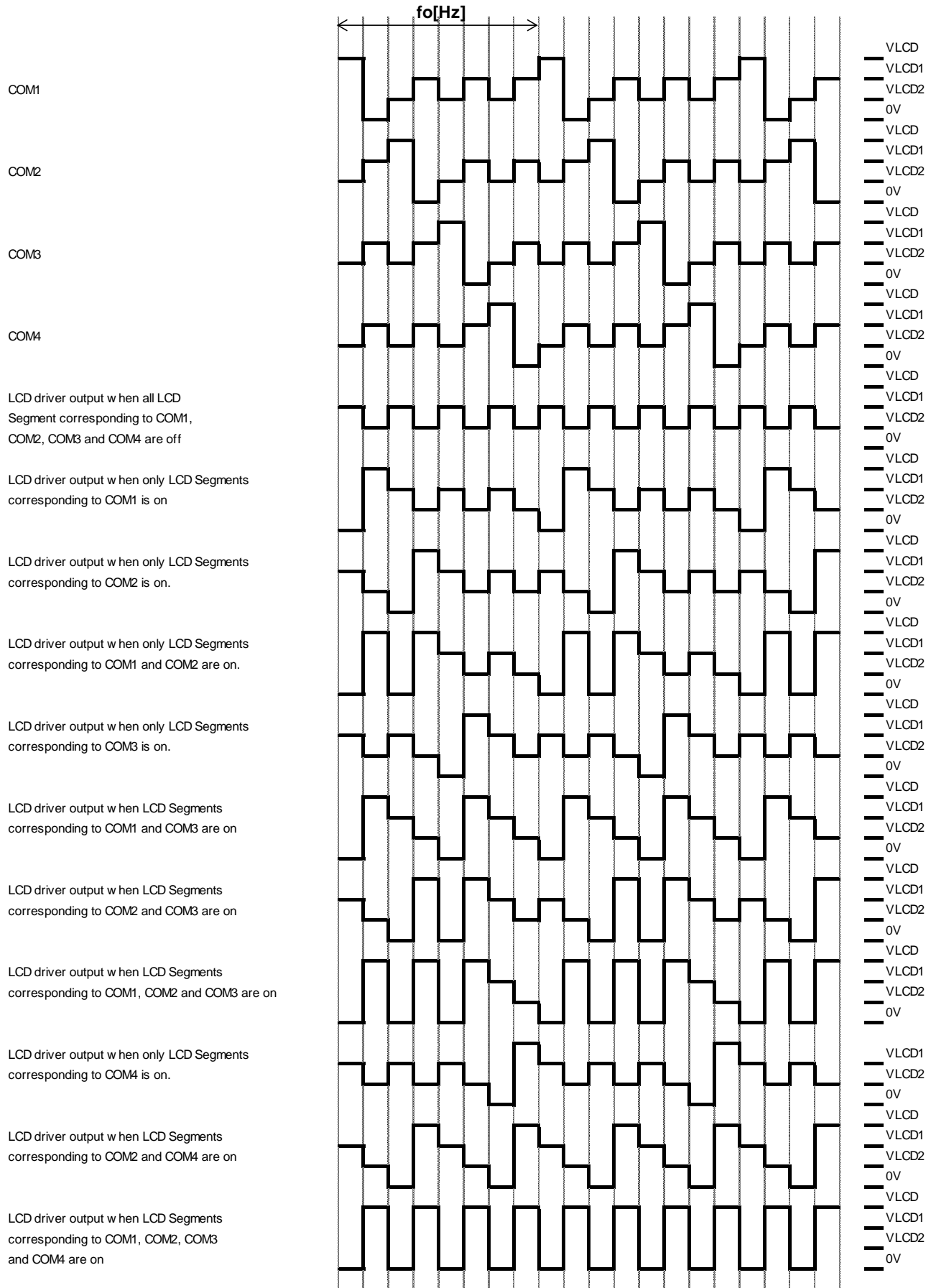

Figure 26. LCD Waveform (Line Inversion, 1/4 Duty, 1/3 Bias)

LCD Driving Waveforms – continued

4. Line Inversion 1/4 Duty 1/2 Bias Drive Scheme

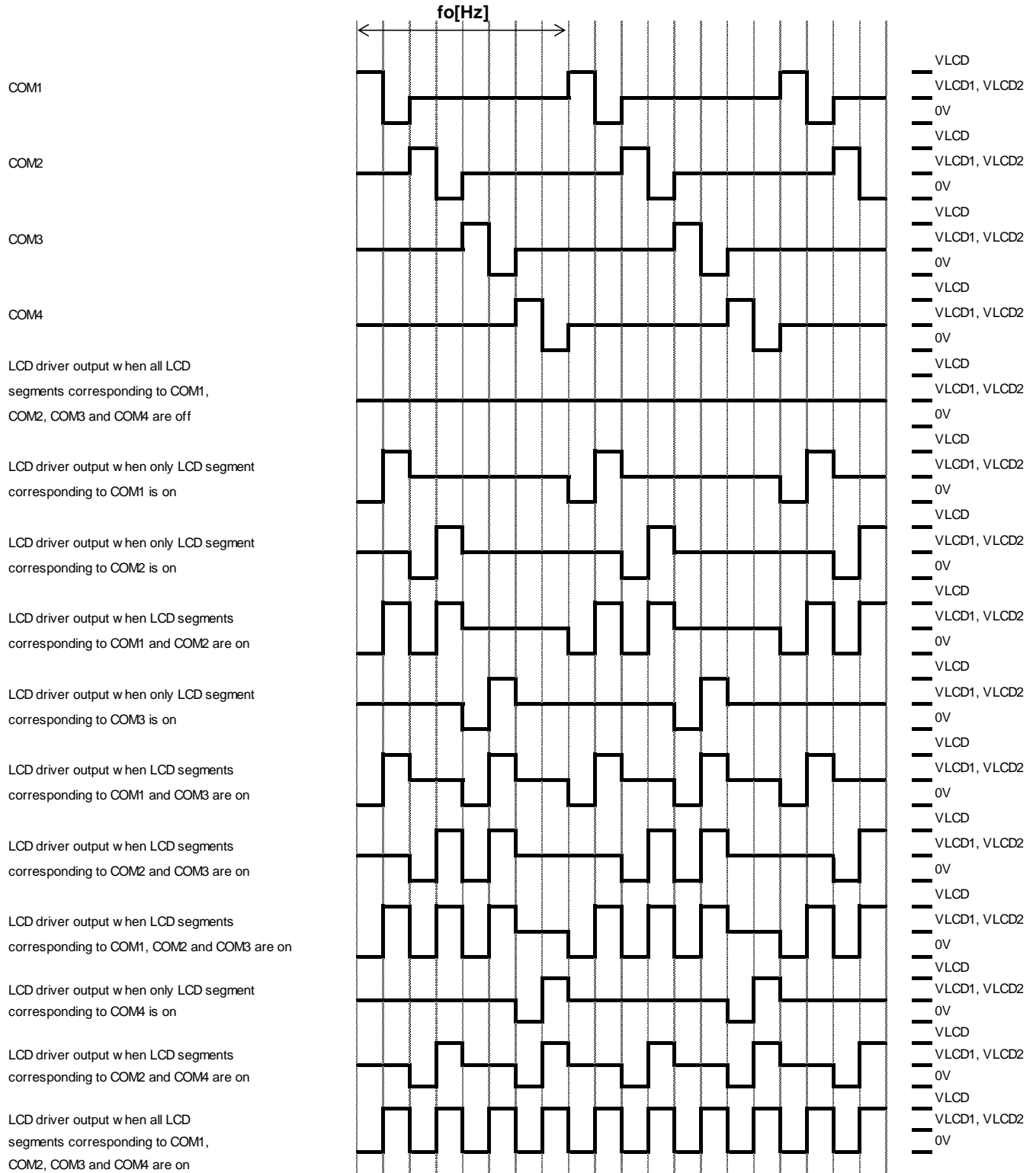

Figure 27. LCD Waveform (Line Inversion, 1/4 Duty, 1/2 Bias)

LCD Driving Waveforms – continued

5. Line Inversion 1/3 Duty 1/3 Bias Drive Scheme

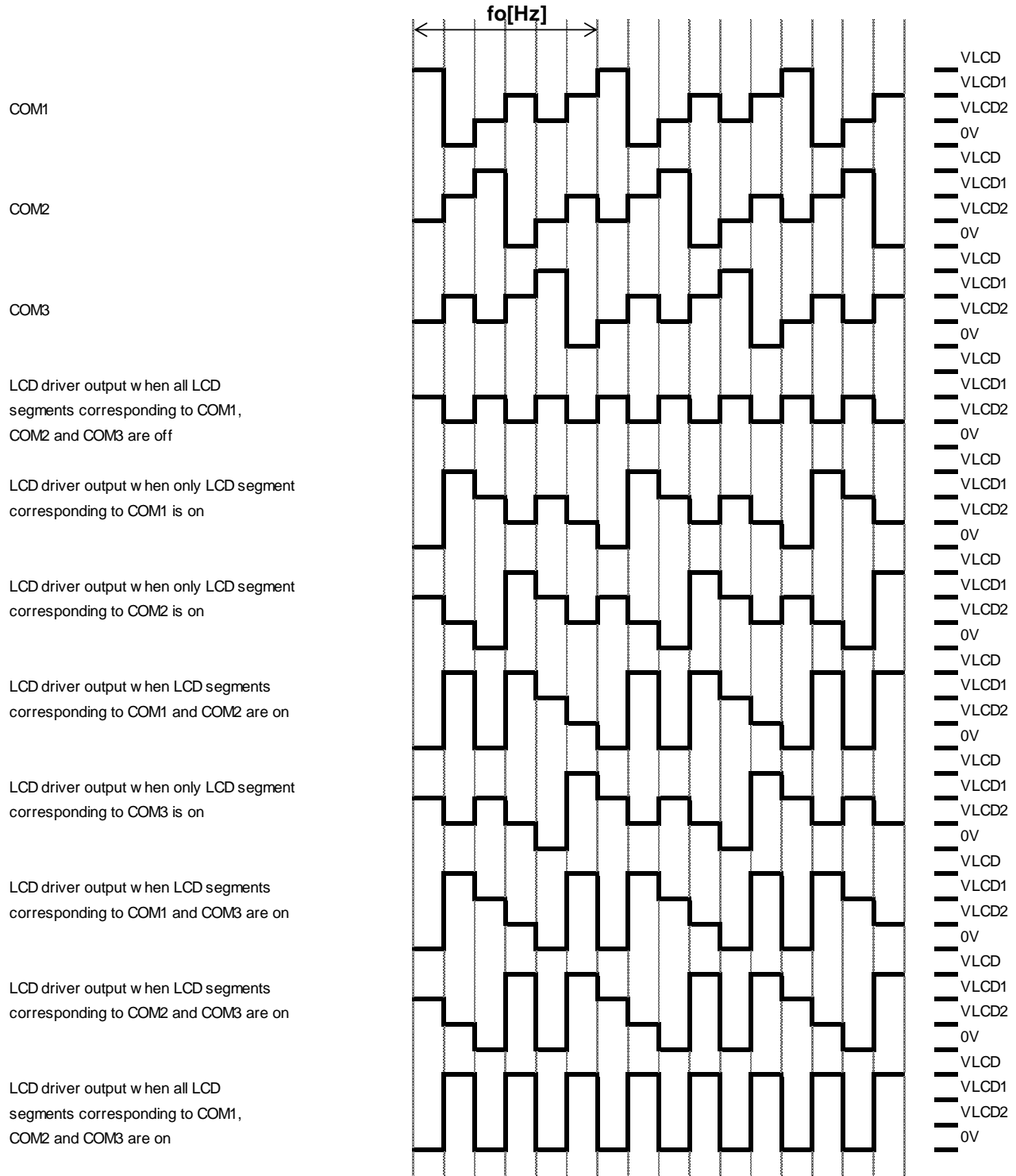

Figure 28. LCD Waveform (Line Inversion, 1/3 Duty, 1/3 Bias)^(Note)

(Note) COM4 function is same as COM1 at 1/3 Duty.

LCD Driving Waveforms – continued

6. Line Inversion 1/3 Duty 1/2 Bias Drive Scheme

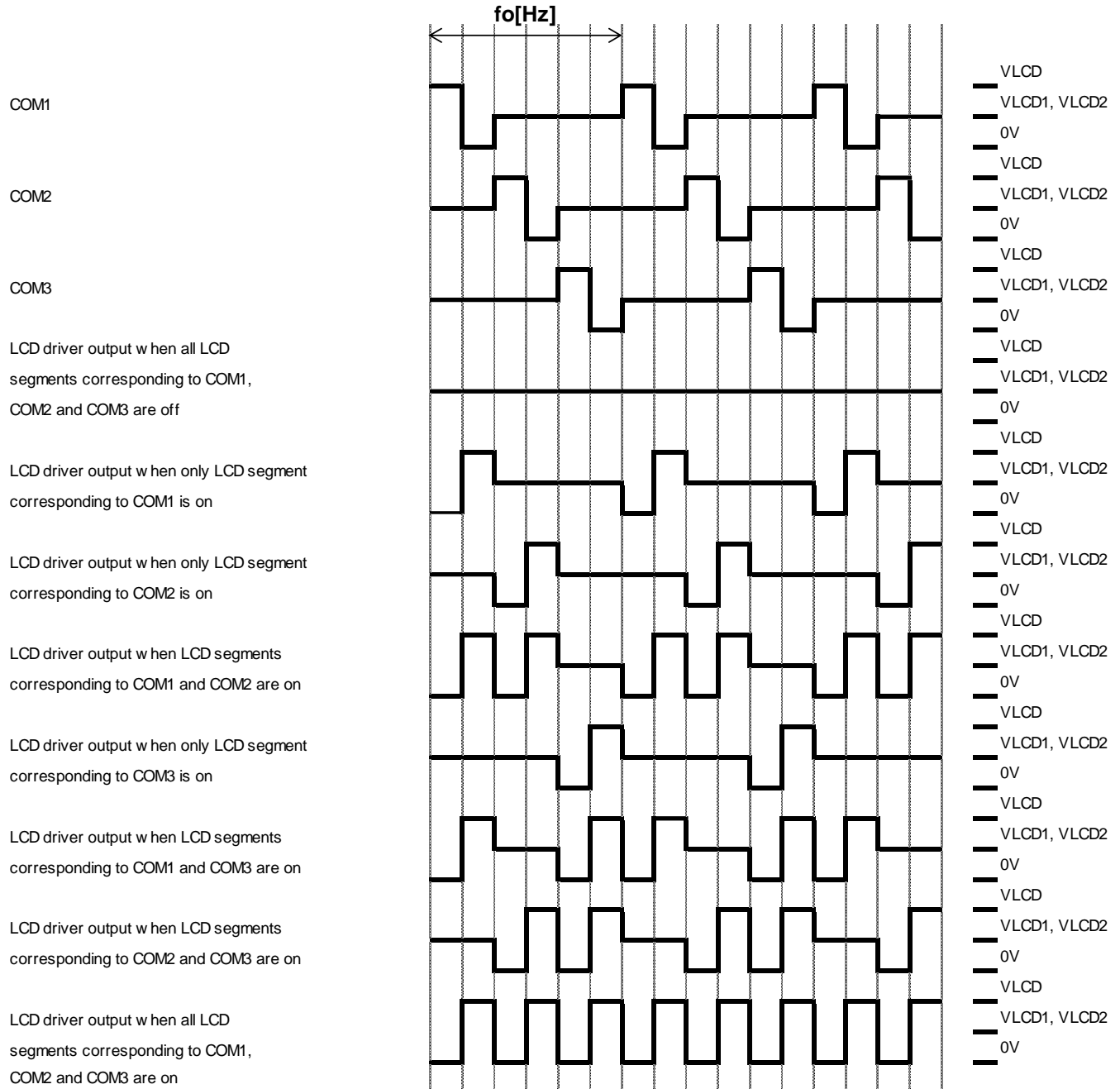

Figure 29. LCD Waveform (Line Inversion, 1/3 Duty, 1/2 Bias)^(Note)

(Note) COM4 function is same as COM1 at 1/3 Duty.

LCD Driving Waveforms – continued

7. Line Inversion Static Drive Scheme

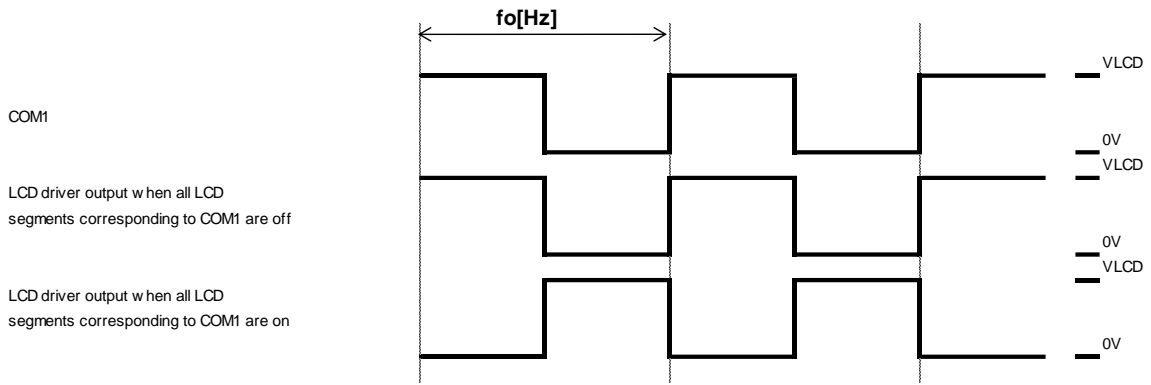

Figure 30. LCD Waveform (Line Inversion, Static)^(Note)

(Note) COM2, COM3 and COM4 function are same as COM1 at Static

LCD Driving Waveforms – continued

8. Frame Inversion 1/5 Duty 1/3 Bias Drive Scheme

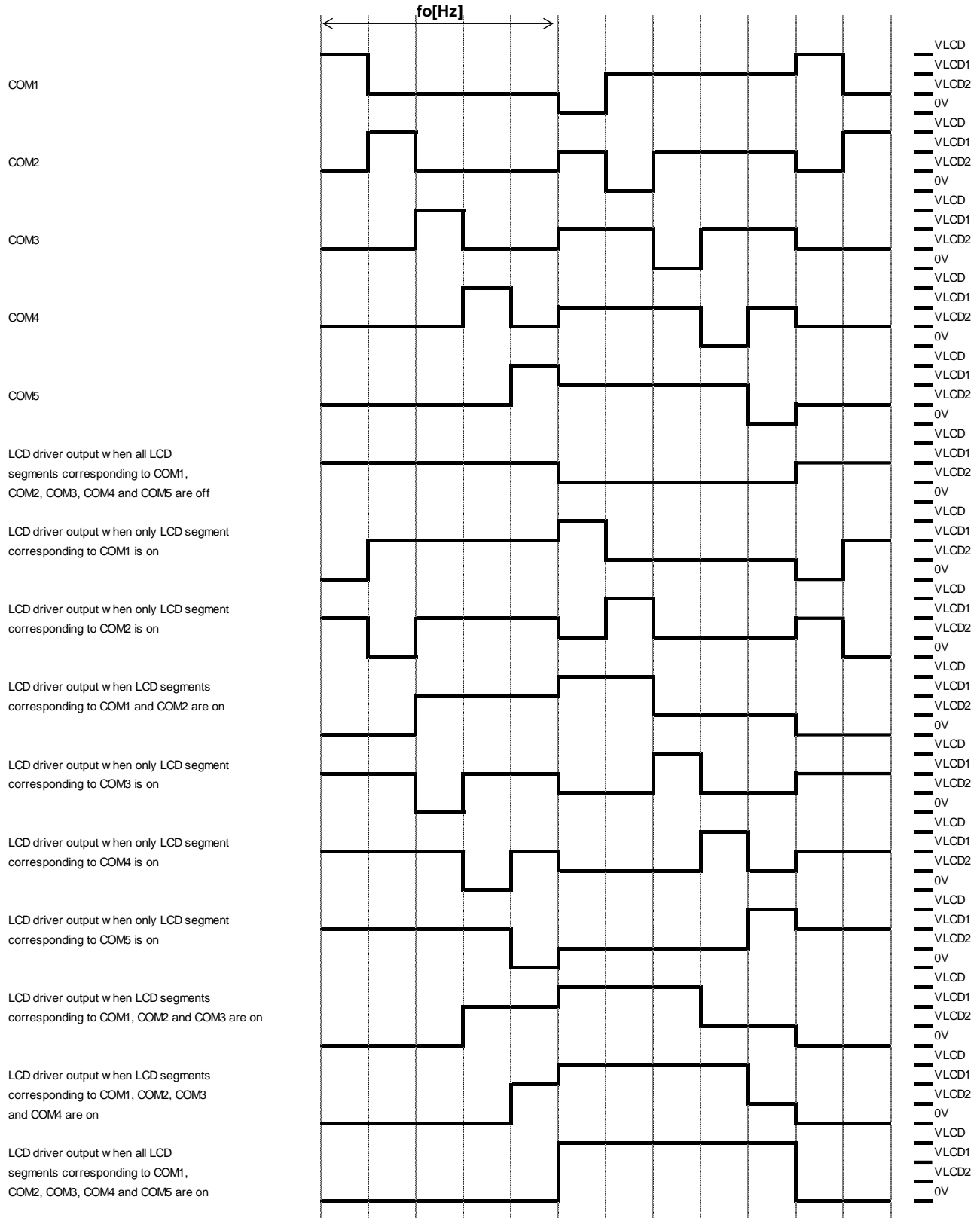

Figure 31. LCD Waveform (Frame Inversion, 1/5 Duty, 1/3 Bias)

LCD Driving Waveforms – continued

9. Frame Inversion 1/5 Duty 1/2 Bias Drive Scheme

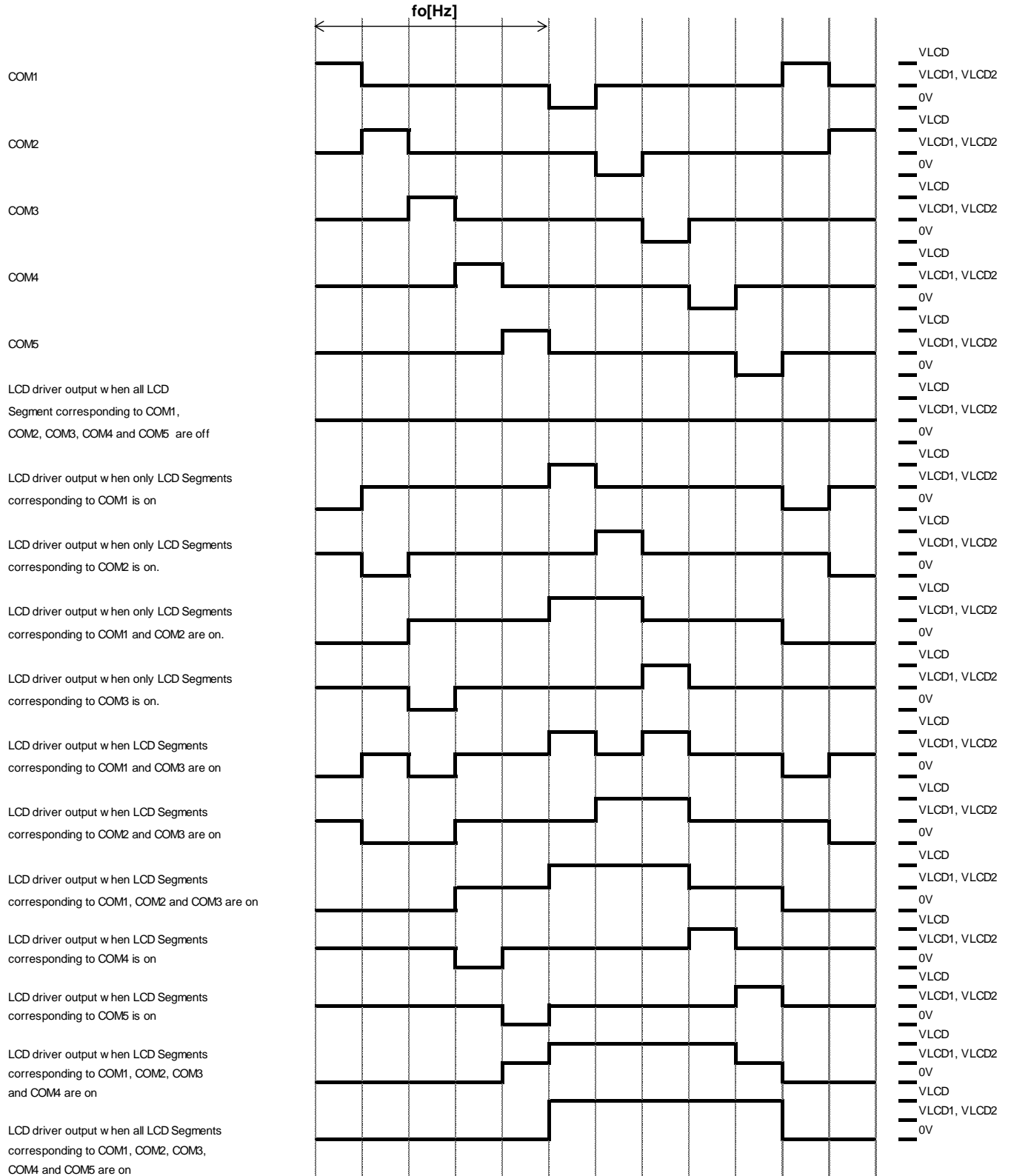

Figure 32. LCD Waveform (Frame Inversion, 1/5 Duty, 1/2 Bias)

LCD Driving Waveforms – continued

10. Frame Inversion 1/4 Duty 1/3 Bias Drive Scheme

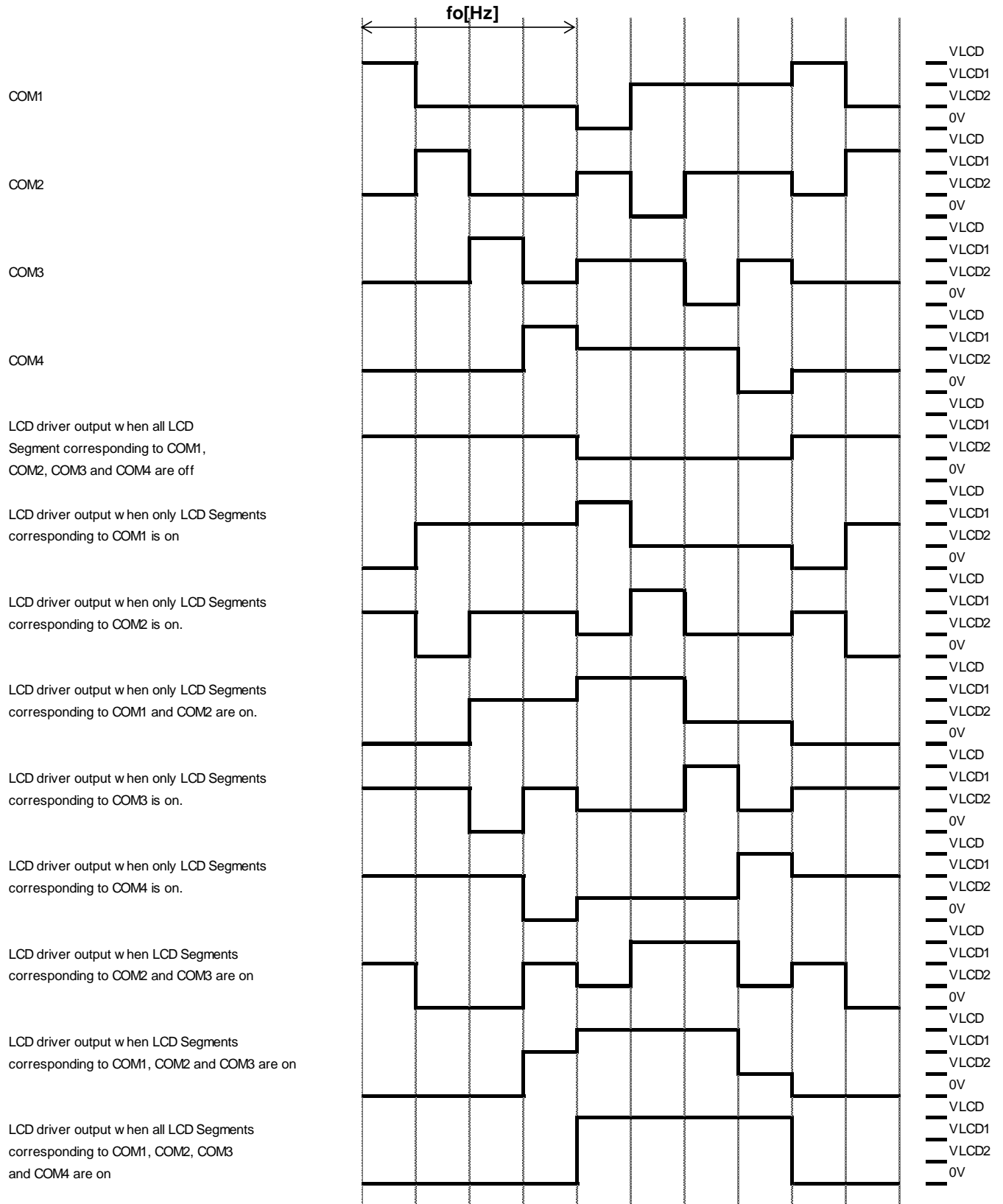

Figure 33. LCD Waveform (Frame Inversion, 1/4 Duty, 1/3 Bias)

LCD Driving Waveforms – continued

11. Frame Inversion 1/4 Duty 1/2 Bias Drive Scheme

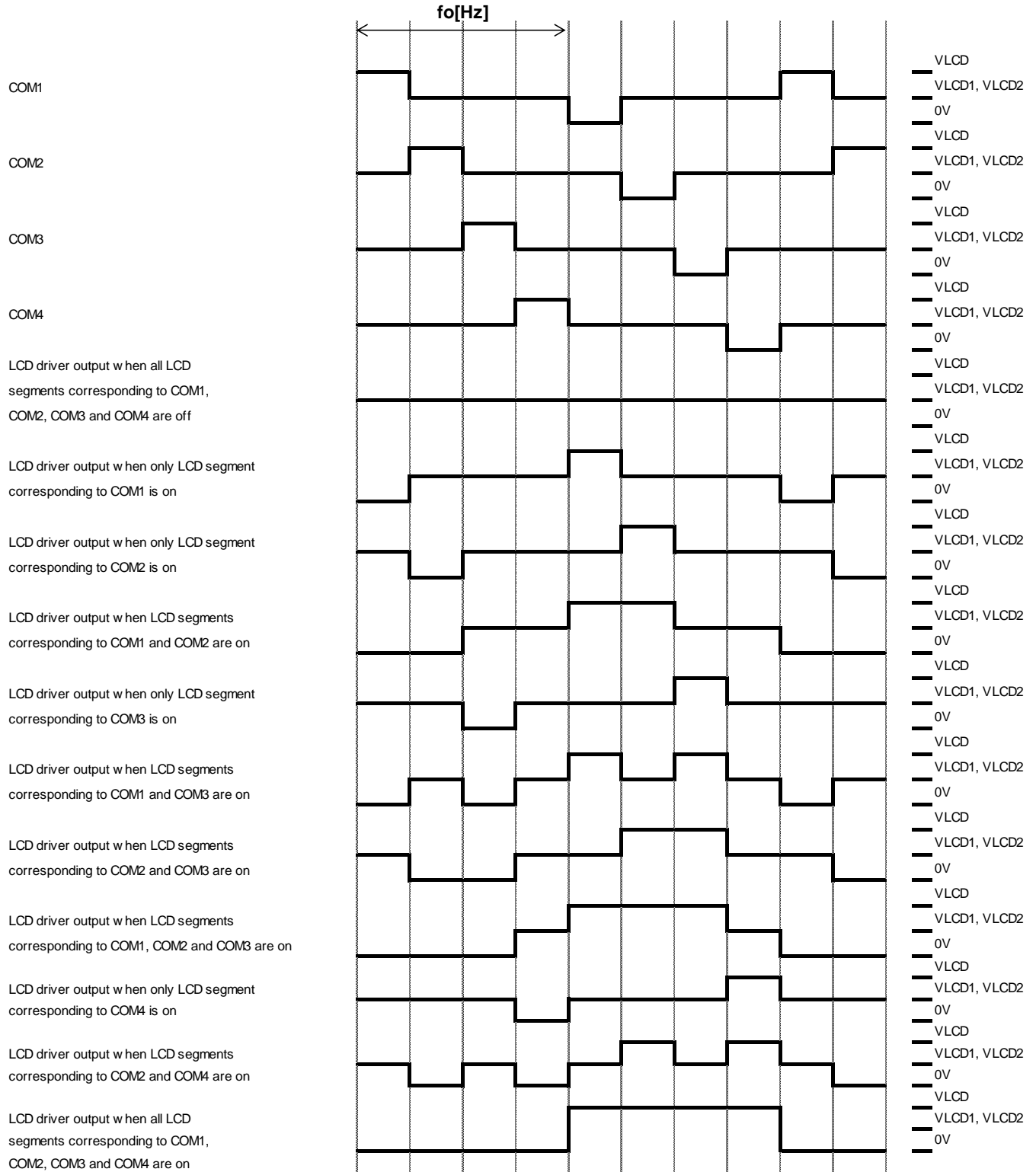

Figure 34. LCD Waveform (Frame Inversion, 1/4 Duty, 1/2 Bias)

LCD Driving Waveforms – continued

12. Frame Inversion 1/3 Duty 1/3 Bias Drive Scheme

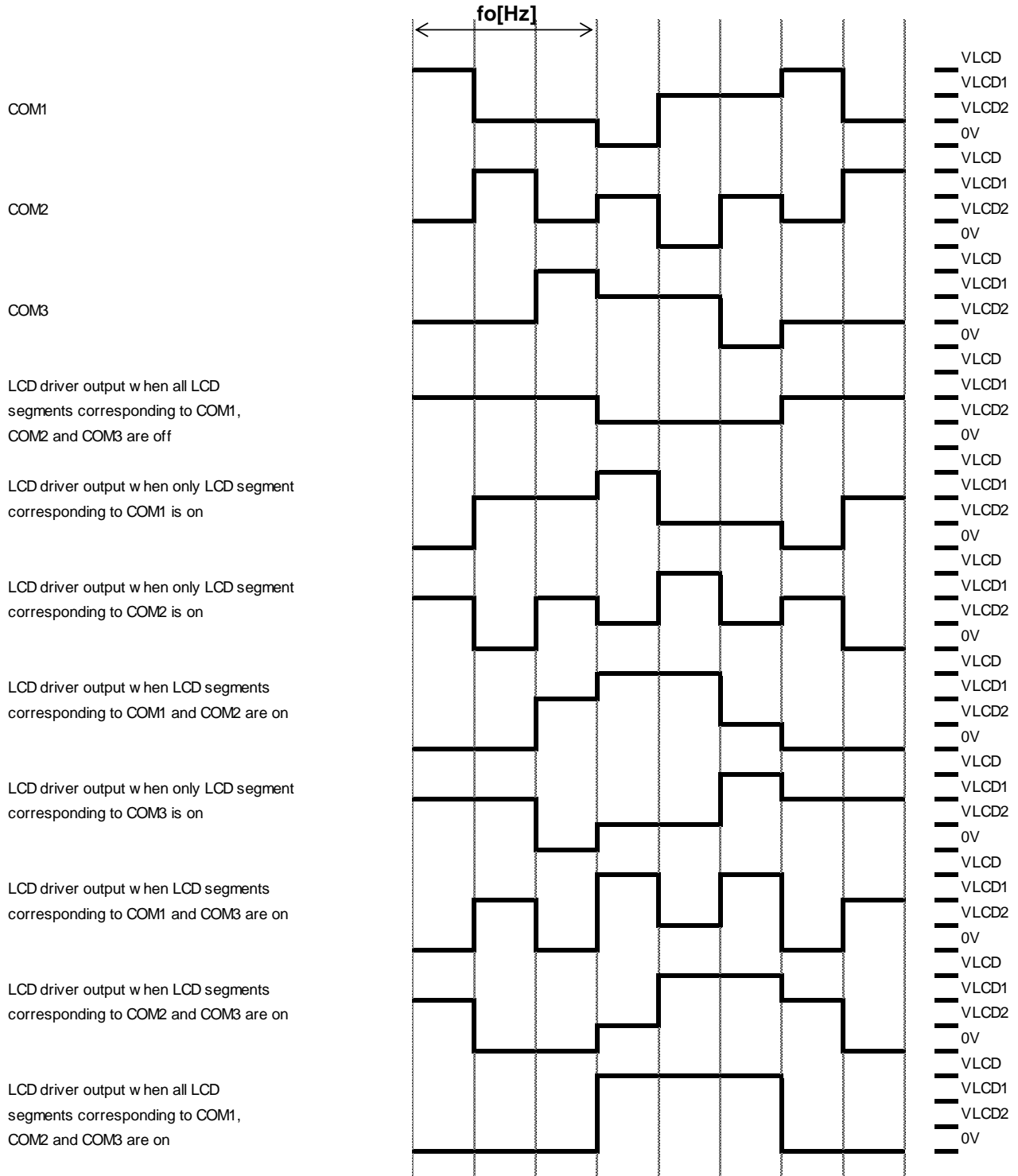

Figure 35. LCD Waveform (Frame Inversion, 1/3 Duty, 1/3 Bias) ^(Note)

(Note) COM4 function is same as COM1 at 1/3 Duty.

LCD Driving Waveforms – continued

13. Frame Inversion 1/3 Duty 1/2 Bias Drive Scheme

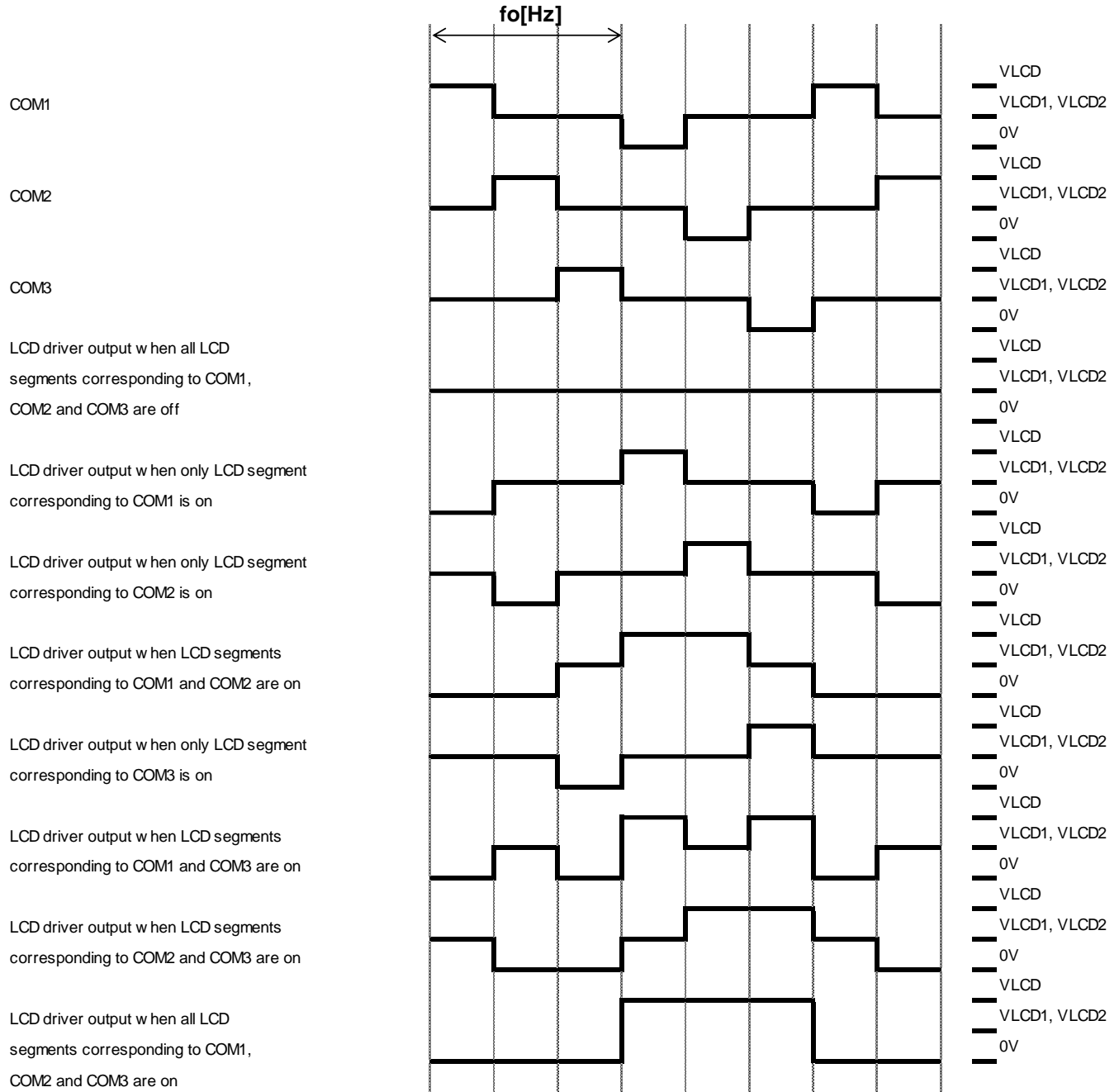

Figure 36. LCD Waveform (Frame Inversion, 1/3 Duty, 1/2 Bias)^(Note)

(Note) COM4 function is same as COM1 at 1/3 Duty.

LCD Driving Waveforms – continued

14. Frame Inversion Static Drive Scheme)

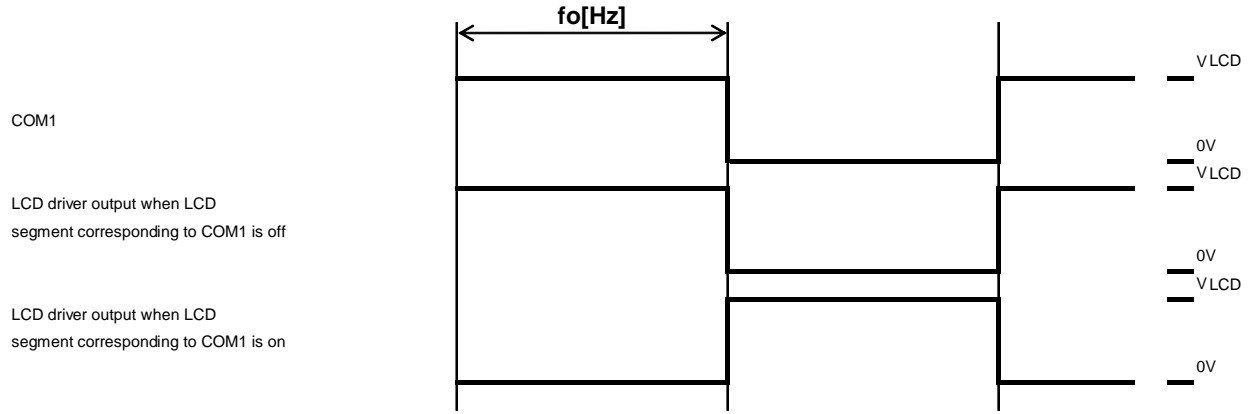

Figure 37. LCD Waveform (Frame Inversion, Static)^(Note)

(Note) COM2, COM3 and COM4 function are same as COM1 at Static

Oscillation Stabilization Time of the Internal Oscillation Circuit

It must be noted that the oscillation of the internal oscillation circuit is unstable for a maximum of 100µs (oscillation stabilization time) after oscillation has started.

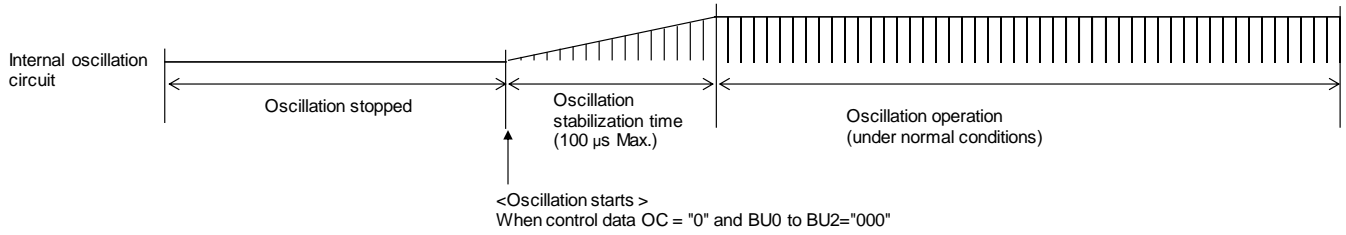

Figure 38. Oscillation Stabilization Time

Power-saving mode operation in external clock mode

After receiving [BU0,BU1,BU2]=[1,1,1], BU97540KV-M enter to Power-saving mode synchronized with frame then Segment and Common ports output VSS level.

Therefore, in external clock mode, it is necessary to input the external clock based on each frame frequency setting after sending [BU0,BU1,BU2]=[1,1,1].

For the required number of clock, refer to "Control Data Functions 6. FC0, FC1, FC2 and FC3".

For example, please input the external clock as below.

[FC0,FC1,FC2,FC3]=[0,0,0,0]: In case of fosc/12288 setting, it needs over 12288clk,

[FC0,FC1,FC2,FC3]=[0,1,0,1]: In case of fosc/4608 setting, it needs over 4608clk,

[FC0,FC1,FC2,FC3]=[1,1,1,1]: In case of fosc/1536 setting, it needs over 1536clk

Please refer to the timing chart below.

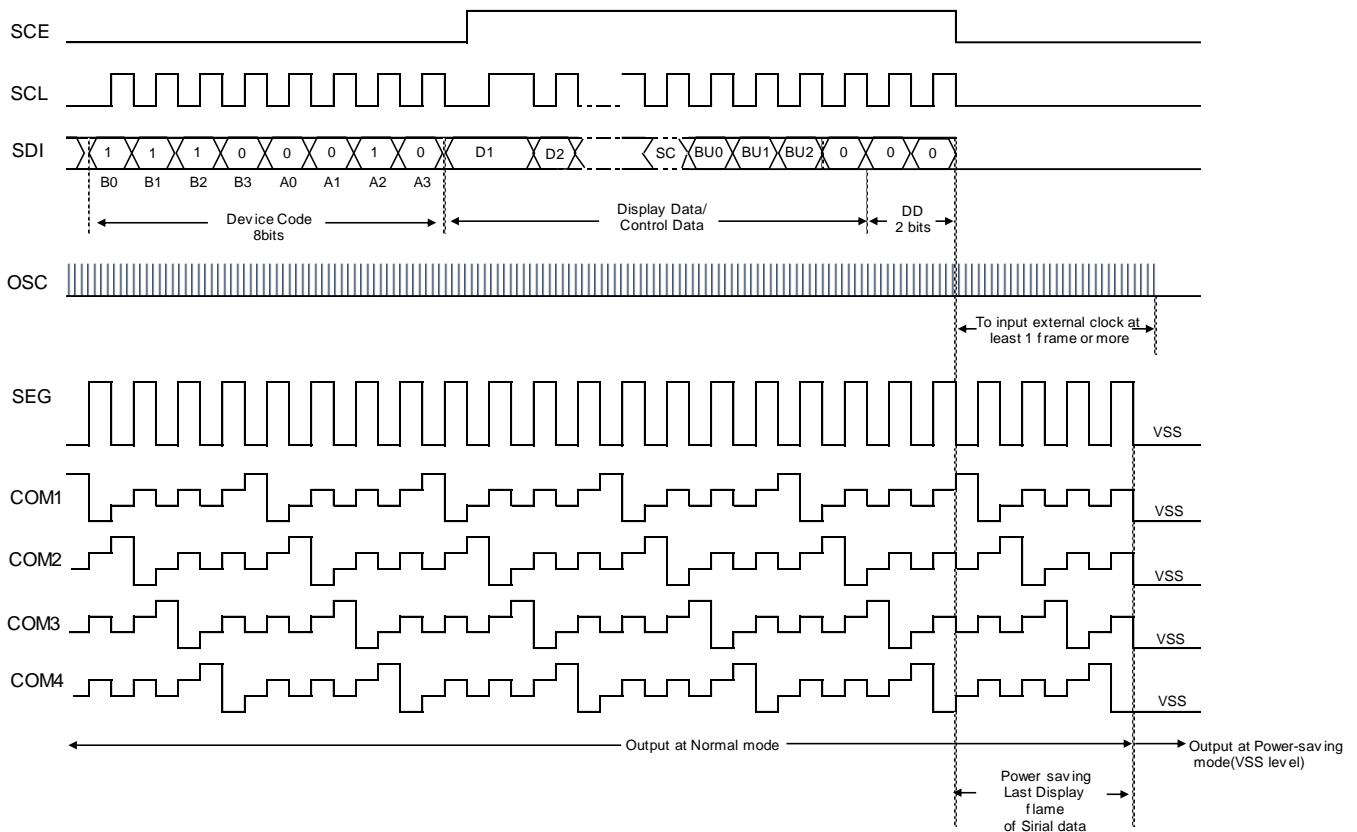

Voltage Detection Type Reset Circuit (VDET)

The Voltage Detection Type Reset Circuit generates an output signal that resets the system when power is applied for the first time and when the power supply voltage drops that is, for example, the power supply voltage is less than or equal to the power down detection voltage ($V_{DET} = 1.8V$ typ). To ensure that this reset function works properly, it is recommended that a capacitor be connected to the power supply line so that both the power supply voltage (VDD) rise time when power is first applied and the power supply voltage (VDD) fall time when the voltage drops are at least 1ms.

To refrain from data transmission is strongly recommended while power supply is rising up or falling down to prevent from the occurrence of disturbances on transmission and reception.

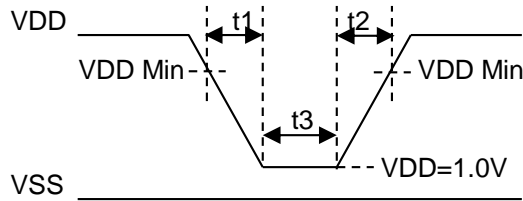

Figure 39. VDET Detection Timing

- Power supply voltage VDD fall time: $t_1 > 1ms$
- Power supply voltage VDD rise time: $t_2 > 1ms$
- Internal reset power supply retain time: $t_3 > 1ms$

Reset Condition

When BU97540KV-M is initialized, the internal status after power supply has been reset as the following table.

Instruction	At Reset Condition
Key Scan Mode	[KM0,KM1,KM2] = [1,1,1]: Keyscan no use
S1/P1/G1 to S9/P9/G9 Pin	[P0,P1,P2,P3] = [0,0,0,0]: all segment output
Inversion Mode	FL = 0: Line Inversion
LCD Bias	DR = 0:1/3 bias
CLKIO/S64, SYNCIO/S65 Pin	SS = 0:Segment output
LCD Duty	[DT0,DT1] = [0,1]:1/4 Duty
DISPLAY Frequency	[FC0,FC1,FC2,FC3] = [0,0,0,0]: $f_{osc} / 12288$
Display Clock Mode	OC = 0:Internal oscillator
LCD Display	SC = 1: OFF
Power PinMode	[BU0, BU1, BU2] = [1,1,1]: Power saving mode
COM5/S67 to COM1/S71 Pin	SSC = 0:Segment output
PWM/GPO Output	PGx = 0:PWM output(x = 1 ~ 9)
PWM Frequency	[PF0,PF1,PF2,PF3,PF4] = [0,0,0,0,0]: $f_{osc} / 4096$
PWM Duty	[Wn0 ~ Wn8] = [0,0,0,0,0,0,0,0,0]: $0/256 \times T_p$ (n = 1 ~ 9, $T_p = 1/f_p$)
Display Contrast Setting	[CT0,CT1,CT2,CT3] = [0,0,0,0]: VLCD Level is $1.00 \times VDD$

Operational Notes

1. Reverse Connection of Power Supply

Connecting the power supply in reverse polarity can damage the IC. Take precautions against reverse polarity when connecting the power supply, such as mounting an external diode between the power supply and the IC's power supply pins.

2. Power Supply Lines

Design the PCB layout pattern to provide low impedance supply lines. Separate the ground and supply lines of the digital and analog blocks to prevent noise in the ground and supply lines of the digital block from affecting the analog block. Furthermore, connect a capacitor to ground at all power supply pins. Consider the effect of temperature and aging on the capacitance value when using electrolytic capacitors.

3. Ground Voltage

Ensure that no pins are at a voltage below that of the ground pin at any time, even during transient condition.

4. Ground Wiring Pattern

When using both small-signal and large-current ground traces, the two ground traces should be routed separately but connected to a single ground at the reference point of the application board to avoid fluctuations in the small-signal ground caused by large currents. Also ensure that the ground traces of external components do not cause variations on the ground voltage. The ground lines must be as short and thick as possible to reduce line impedance.

5. Recommended Operating Conditions

These conditions represent a range within which the expected characteristics of the IC can be approximately obtained. The electrical characteristics are guaranteed under the conditions of each parameter.

6. Inrush Current

When power is first supplied to the IC, it is possible that the internal logic may be unstable and inrush current may flow instantaneously due to the internal powering sequence and delays, especially if the IC has more than one power supply. Therefore, give special consideration to power coupling capacitance, power wiring, width of ground wiring, and routing of connections.

7. Operation Under Strong Electromagnetic Field

Operating the IC in the presence of a strong electromagnetic field may cause the IC to malfunction.

8. Testing on Application Boards

When testing the IC on an application board, connecting a capacitor directly to a low-impedance output pin may subject the IC to stress. Always discharge capacitors completely after each process or step. The IC's power supply should always be turned off completely before connecting or removing it from the test setup during the inspection process. To prevent damage from static discharge, ground the IC during assembly and use similar precautions during transport and storage.

9. Inter-pin Short and Mounting Errors

Ensure that the direction and position are correct when mounting the IC on the PCB. Incorrect mounting may result in damaging the IC. Avoid nearby pins being shorted to each other especially to ground, power supply and output pin. Inter-pin shorts could be due to many reasons such as metal particles, water droplets (in very humid environment) and unintentional solder bridge deposited in between pins during assembly to name a few.

Operational Notes – continued**10. Unused Input Pins**

Input pins of an IC are often connected to the gate of a MOS transistor. The gate has extremely high impedance and extremely low capacitance. If left unconnected, the electric field from the outside can easily charge it. The small charge acquired in this way is enough to produce a significant effect on the conduction through the transistor and cause unexpected operation of the IC. So unless otherwise specified, unused input pins should be connected to the power supply or ground line.

11. Regarding the Input Pin of the IC

In the construction of this IC, P-N junctions are inevitably formed creating parasitic diodes or transistors. The operation of these parasitic elements can result in mutual interference among circuits, operational faults, or physical damage. Therefore, conditions which cause these parasitic elements to operate, such as applying a voltage to an input pin lower than the ground voltage should be avoided. Furthermore, do not apply a voltage to the input pins when no power supply voltage is applied to the IC. Even if the power supply voltage is applied, make sure that the input pins have voltages within the values specified in the electrical characteristics of this IC.

Ordering Information

B U 9 7 5 4 0 K V	-	M E 2
Part Number	Package KV : VQFP80	Product Rank M: for Automotive Packaging Specification E2: Embossed tape and reel (VQFP80)

Marking Diagram

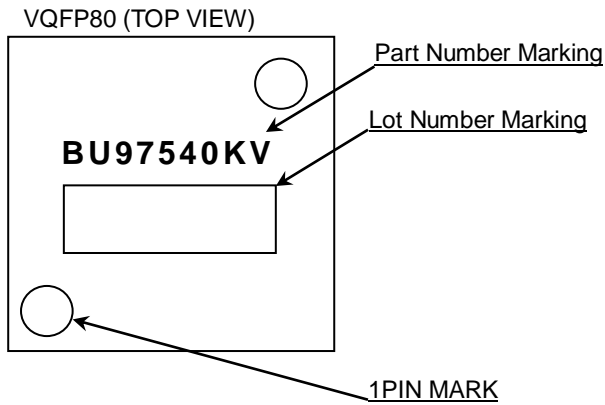

Physical Dimension, Tape and Reel Information

Package Name	VQFP80
--------------	--------

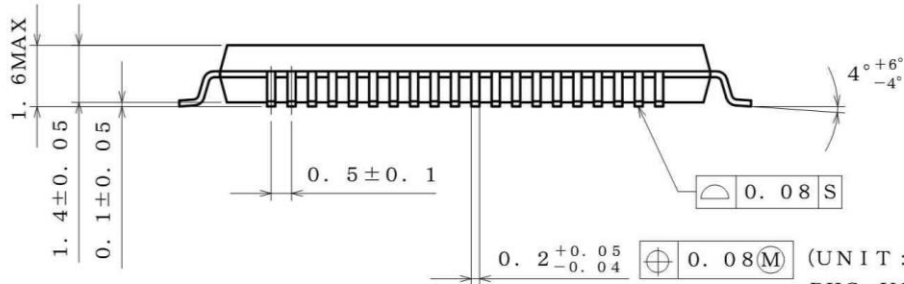
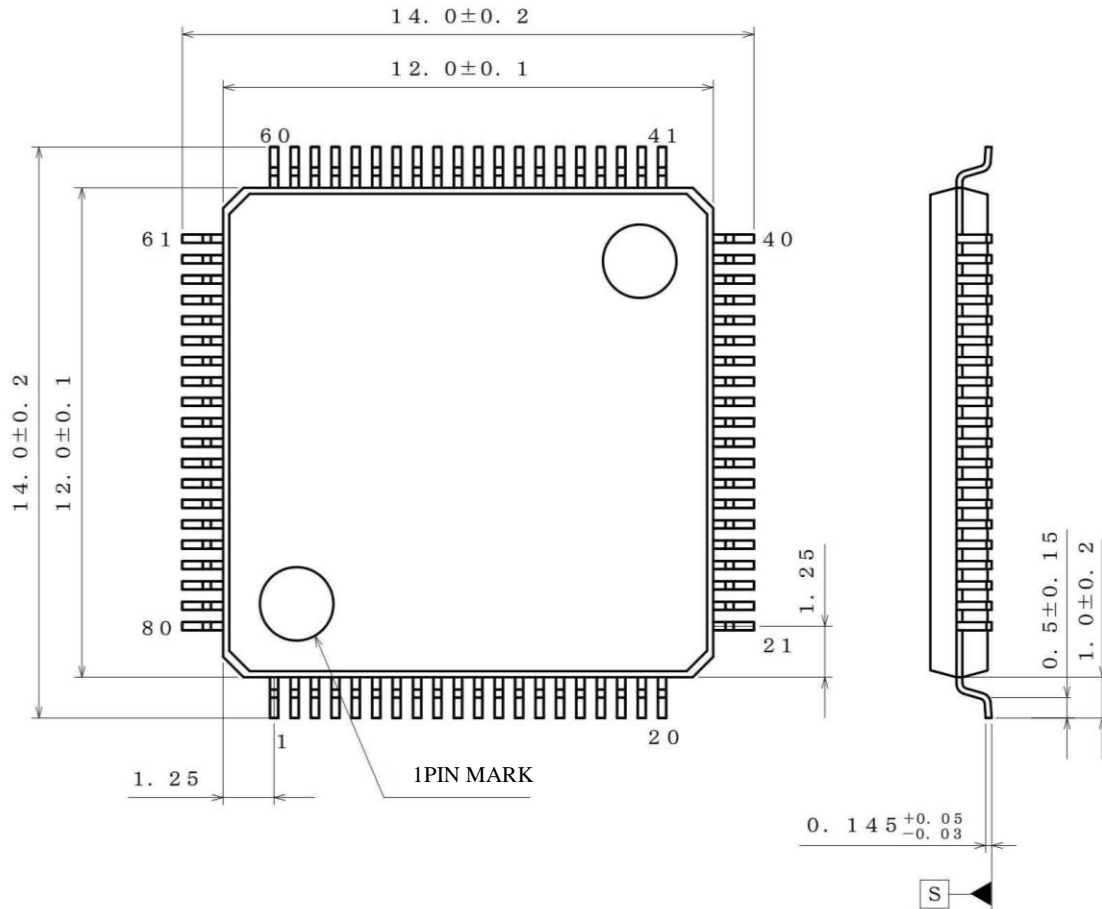

(UNIT : mm)
 PKG : VQFP80
 Drawing No. EX253-5001-2

<Tape and Reel information>

Tape	Embossed carrier tape (with dry pack)
Quantity	1000pcs
Direction of feed	E2 (The direction is the 1pin of product is at the upper left when you hold reel on the left hand and you pull out the tape on the right hand)

*Order quantity needs to be multiple of the minimum quantity.

Revision History

Date	Revision	Changes
02.Jun.2015	001	New Release
29.Jun.2015	002	Modified Typical Application Circuit in Page2. Modified S66/TESTIN Pin description(Handling when unused) in Page 7. Modified comment of figure.39 in Page 61.
11.Jan.2019	003	Page.3 Delete temperature condition in Absolute Maximum Ratings Page.3 Move Operational Temperature Range to Recommend Operating Conditions Page.3 Add Caution 2 in Absolute Maximum Ratings (Transcription from Thermal Consideration in Operational Notes) Page.4 Add tr,tf item in Oscillation Characteristics Page.8 Modify Figure.6 I/O Equivalent Circuit Page.17 Add explanation in "3. FL: Line Inversion or Frame Inversion control data". Page.19 Add notice of External Clock input timing function in "8. OC: Internal oscillator operating mode/External clock operating mode switching control data" Page.21 Add Note and The relationship of LCD display contrast setting and VLCD voltage in "14. CT0, CT1, CT2 and CT3: Display Contrast setting control data" Page.61 Add notice of Power-saving mode operation in external clock mode Page.62 Add notice in Voltage Detection Type Reset Circuit (VDET) (Transcription from Data transmission in Operational Notes) Page.63 Delete Thermal Consideration (Move to Absolute Maximum Ratings) Page.64 Delete Data transmission (Move to Voltage Detection Type Reset Circuit (VDET)) Change from "1/1 duty" to "Static" Add Reset condition in each Control Data Function Change "Sleep mode" to "Power-saving mode" Modify number of Note Correction of errors
18.Jul. 2019	004	Page. 10,12,14,16 Add Description

Notice

Precaution on using ROHM Products

1. If you intend to use our Products in devices requiring extremely high reliability (such as medical equipment ^(Note 1), aircraft/spacecraft, nuclear power controllers, etc.) and whose malfunction or failure may cause loss of human life, bodily injury or serious damage to property ("Specific Applications"), please consult with the ROHM sales representative in advance. Unless otherwise agreed in writing by ROHM in advance, ROHM shall not be in any way responsible or liable for any damages, expenses or losses incurred by you or third parties arising from the use of any ROHM's Products for Specific Applications.

(Note1) Medical Equipment Classification of the Specific Applications

JAPAN	USA	EU	CHINA
CLASS III	CLASS III	CLASS II b	CLASS III
CLASS IV		CLASS III	

2. ROHM designs and manufactures its Products subject to strict quality control system. However, semiconductor products can fail or malfunction at a certain rate. Please be sure to implement, at your own responsibilities, adequate safety measures including but not limited to fail-safe design against the physical injury, damage to any property, which a failure or malfunction of our Products may cause. The following are examples of safety measures:
 - [a] Installation of protection circuits or other protective devices to improve system safety
 - [b] Installation of redundant circuits to reduce the impact of single or multiple circuit failure
3. Our Products are not designed under any special or extraordinary environments or conditions, as exemplified below. Accordingly, ROHM shall not be in any way responsible or liable for any damages, expenses or losses arising from the use of any ROHM's Products under any special or extraordinary environments or conditions. If you intend to use our Products under any special or extraordinary environments or conditions (as exemplified below), your independent verification and confirmation of product performance, reliability, etc. prior to use, must be necessary:
 - [a] Use of our Products in any types of liquid, including water, oils, chemicals, and organic solvents
 - [b] Use of our Products outdoors or in places where the Products are exposed to direct sunlight or dust
 - [c] Use of our Products in places where the Products are exposed to sea wind or corrosive gases, including Cl₂, H₂S, NH₃, SO₂, and NO₂
 - [d] Use of our Products in places where the Products are exposed to static electricity or electromagnetic waves
 - [e] Use of our Products in proximity to heat-producing components, plastic cords, or other flammable items
 - [f] Sealing or coating our Products with resin or other coating materials
 - [g] Use of our Products without cleaning residue of flux (Exclude cases where no-clean type fluxes is used. However, recommend sufficiently about the residue.); or Washing our Products by using water or water-soluble cleaning agents for cleaning residue after soldering
 - [h] Use of the Products in places subject to dew condensation
4. The Products are not subject to radiation-proof design.
5. Please verify and confirm characteristics of the final or mounted products in using the Products.
6. In particular, if a transient load (a large amount of load applied in a short period of time, such as pulse, is applied, confirmation of performance characteristics after on-board mounting is strongly recommended. Avoid applying power exceeding normal rated power; exceeding the power rating under steady-state loading condition may negatively affect product performance and reliability.
7. De-rate Power Dissipation depending on ambient temperature. When used in sealed area, confirm that it is the use in the range that does not exceed the maximum junction temperature.
8. Confirm that operation temperature is within the specified range described in the product specification.
9. ROHM shall not be in any way responsible or liable for failure induced under deviant condition from what is defined in this document.

Precaution for Mounting / Circuit board design

1. When a highly active halogenous (chlorine, bromine, etc.) flux is used, the residue of flux may negatively affect product performance and reliability.
2. In principle, the reflow soldering method must be used on a surface-mount products, the flow soldering method must be used on a through hole mount products. If the flow soldering method is preferred on a surface-mount products, please consult with the ROHM representative in advance.

For details, please refer to ROHM Mounting specification

Precautions Regarding Application Examples and External Circuits

1. If change is made to the constant of an external circuit, please allow a sufficient margin considering variations of the characteristics of the Products and external components, including transient characteristics, as well as static characteristics.
2. You agree that application notes, reference designs, and associated data and information contained in this document are presented only as guidance for Products use. Therefore, in case you use such information, you are solely responsible for it and you must exercise your own independent verification and judgment in the use of such information contained in this document. ROHM shall not be in any way responsible or liable for any damages, expenses or losses incurred by you or third parties arising from the use of such information.

Precaution for Electrostatic

This Product is electrostatic sensitive product, which may be damaged due to electrostatic discharge. Please take proper caution in your manufacturing process and storage so that voltage exceeding the Products maximum rating will not be applied to Products. Please take special care under dry condition (e.g. Grounding of human body / equipment / solder iron, isolation from charged objects, setting of Ionizer, friction prevention and temperature / humidity control).

Precaution for Storage / Transportation

1. Product performance and soldered connections may deteriorate if the Products are stored in the places where:
 - [a] the Products are exposed to sea winds or corrosive gases, including Cl₂, H₂S, NH₃, SO₂, and NO₂
 - [b] the temperature or humidity exceeds those recommended by ROHM
 - [c] the Products are exposed to direct sunshine or condensation
 - [d] the Products are exposed to high Electrostatic
2. Even under ROHM recommended storage condition, solderability of products out of recommended storage time period may be degraded. It is strongly recommended to confirm solderability before using Products of which storage time is exceeding the recommended storage time period.
3. Store / transport cartons in the correct direction, which is indicated on a carton with a symbol. Otherwise bent leads may occur due to excessive stress applied when dropping of a carton.
4. Use Products within the specified time after opening a humidity barrier bag. Baking is required before using Products of which storage time is exceeding the recommended storage time period.

Precaution for Product Label

A two-dimensional barcode printed on ROHM Products label is for ROHM's internal use only.

Precaution for Disposition

When disposing Products please dispose them properly using an authorized industry waste company.

Precaution for Foreign Exchange and Foreign Trade act

Since concerned goods might be fallen under listed items of export control prescribed by Foreign exchange and Foreign trade act, please consult with ROHM in case of export.

Precaution Regarding Intellectual Property Rights

1. All information and data including but not limited to application example contained in this document is for reference only. ROHM does not warrant that foregoing information or data will not infringe any intellectual property rights or any other rights of any third party regarding such information or data.
2. ROHM shall not have any obligations where the claims, actions or demands arising from the combination of the Products with other articles such as components, circuits, systems or external equipment (including software).
3. No license, expressly or implied, is granted hereby under any intellectual property rights or other rights of ROHM or any third parties with respect to the Products or the information contained in this document. Provided, however, that ROHM will not assert its intellectual property rights or other rights against you or your customers to the extent necessary to manufacture or sell products containing the Products, subject to the terms and conditions herein.

Other Precaution

1. This document may not be reprinted or reproduced, in whole or in part, without prior written consent of ROHM.
2. The Products may not be disassembled, converted, modified, reproduced or otherwise changed without prior written consent of ROHM.
3. In no event shall you use in any way whatsoever the Products and the related technical information contained in the Products or this document for any military purposes, including but not limited to, the development of mass-destruction weapons.
4. The proper names of companies or products described in this document are trademarks or registered trademarks of ROHM, its affiliated companies or third parties.

General Precaution







1. Before you use our Products, you are requested to carefully read this document and fully understand its contents. ROHM shall not be in any way responsible or liable for failure, malfunction or accident arising from the use of any ROHM's Products against warning, caution or note contained in this document.
2. All information contained in this document is current as of the issuing date and subject to change without any prior notice. Before purchasing or using ROHM's Products, please confirm the latest information with a ROHM sales representative.
3. The information contained in this document is provided on an "as is" basis and ROHM does not warrant that all information contained in this document is accurate and/or error-free. ROHM shall not be in any way responsible or liable for any damages, expenses or losses incurred by you or third parties resulting from inaccuracy or errors of or concerning such information.

Looking for pricing, stock, or lifecycle information?

Click below to explore more details on WIN SOURCE:

-  [View BU97540KV-ME2 on WIN SOURCE](#)
-  [Rohm Semiconductor](#) Information

Optimize Your Supply Chain with WIN SOURCE Solutions

-  Global Sourcing Solution
-  Obsolete Management
-  Cost Control Management
-  Shortage Management
-  Alternative Solution
-  Excess Inventory Management