



THE DATASHEET OF BQ25306RTER



BQ25306 Standalone 17-V, 3.0-A 1-2 Cell Buck Battery Charger

1 Features

- Standalone charger and easy to configure
- High-efficiency, 1.2-MHz, synchronous switch-mode buck charger
 - 92.5% charge efficiency at 2A from 5-V input for 1-cell battery
 - 91.8% charge efficiency at 2A from 9-V input for 1-cell battery
 - 95% charge efficiency at 2A from 12-V input for 2-cell battery
- Single input to support USB input and high voltage adaptors
 - Support 4.1-V - 17-V input voltage range with 28-V absolute maximum input voltage rating
 - Input Voltage Dynamic Power Management (VINDPM) tracking battery voltage
- High integration
 - Integrated reverse blocking and synchronous switching MOSFET
 - Internal input and charge current sense
 - Internal loop compensation
 - Integrated bootstrap diode
- 3.4-V to 9.0-V programmable charge voltage
- 3.0-A maximum fast charge current
- 200-nA low battery leakage current at 4.5-V V_{BAT}
- 4.25- μ A VBUS supply current in IC disable mode
- Charge current thermal regulation at 120°C
- Precharge current: 10% of fast charge current
- Termination current: 10% of fast charge current
- Charge accuracy
 - $\pm 0.5\%$ charge voltage regulation
 - $\pm 10\%$ charge current regulation
- Safety
 - Thermal regulation and thermal shutdown
 - Input Under-Voltage Lockout (UVLO) and Over-Voltage Protection (OVP)
 - Battery overcharge protection
 - Safety timer for precharge and fast charge
 - Charge disabled if battery feedback pin FB is open or short
 - Cold/hot battery temperature protection
 - Fault report on STAT pin
- Available in WQFN 3x3-16 package

2 Applications

- [Wireless speaker](#)
- [Gaming](#)
- [Cradle charger](#)
- [Medical](#)

3 Description

The BQ25306 is a highly-integrated standalone switch-mode battery charger for 1-cell and 2-cell Li-ion, Li-polymer, and LiFePO₄ batteries. The BQ25306 supports 4.1-V to 17-V input voltage and 3-A fast charge current. The integrated current sensing topology of the device enables high charge efficiency and low BOM cost. The best-in-class 200-nA low quiescent current of the device conserves battery energy and maximizes the shelf time for portable devices. The BQ25306 is available in a 3x3 WQFN package for easy 2-layer layout and space limited applications.

Device Information

PART NUMBER ⁽¹⁾	PACKAGE	BODY SIZE (NOM)
BQ25306	WQFN (16)	3.00mm x 3.00mm

- (1) For all available packages, see the orderable addendum at the end of the data sheet.

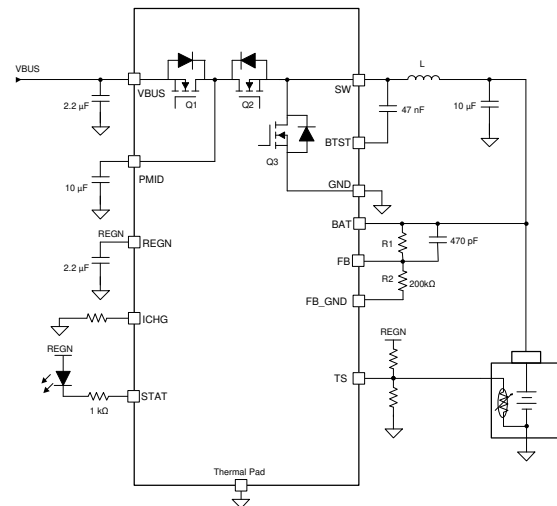

Simplified Application



Table of Contents

1 Features	1	9.4 Device Functional Modes.....	19
2 Applications	1	10 Application and Implementation	20
3 Description	1	10.1 Application Information.....	20
4 Revision History	2	10.2 Typical Applications.....	20
5 Description (continued)	3	11 Power Supply Recommendations	28
6 Device Comparison Table	4	12 Layout	29
7 Pin Configuration and Functions	5	12.1 Layout Guidelines.....	29
8 Specifications	7	12.2 Layout Example.....	29
8.1 Absolute Maximum Ratings	7	13 Device and Documentation Support	31
8.2 ESD Ratings	7	13.1 Device Support.....	31
8.3 Recommended Operating Conditions	7	13.2 Documentation Support.....	31
8.4 Thermal Information	8	13.3 Receiving Notification of Documentation Updates..	31
8.5 Electrical Characteristics	8	13.4 Support Resources.....	31
8.6 Timing Requirements	11	13.5 Trademarks.....	31
8.7 Typical Characteristics.....	12	13.6 Electrostatic Discharge Caution.....	31
9 Detailed Description	14	13.7 Glossary.....	31
9.1 Overview.....	14	14 Mechanical, Packaging, and Orderable	
9.2 Functional Block Diagram.....	14	Information	32
9.3 Feature Description.....	15		

4 Revision History

NOTE: Page numbers for previous revisions may differ from page numbers in the current version.

Changes from Revision * (March 2020) to Revision A (November 2020)	Page
• Changed from Advance Information to Production Data.....	1

5 Description (continued)

The BQ25306 supports a 4.1-V to 17-V input to charge either single cell batteries or dual batteries in series with charge voltage from 3.4 V to 9.0 V programmable by resistor divider. The BQ25306 provides up to 3-A continuous charge current to a single cell (1S) battery or dual cell batteries in series (2S). The device features fast charging for portable devices. Its input voltage regulation delivers maximum charging power to the battery from input source. The solution is highly integrated with an input reverse-blocking FET (RBFET, Q1), high-side switching FET (HSFET, Q2), and low-side switching FET (LSFET, Q3).

The BQ25306 features lossless integrated current sensing to reduce power loss and BOM cost with minimized component count. It also integrates a bootstrap diode for the high-side gate drive and battery temperature monitor to simplify system design. The device initiates and completes a charging cycle without host control. The BQ25306 charge voltage and charge current are set by external resistors. The BQ25306 charge voltage is programmed by an external resistor divider and it charges the battery in three phases: pre-conditioning, constant current, and constant voltage. At the end of the charging cycle, the charger automatically terminates if the charge current is below the termination current threshold and the battery voltage is above the recharge threshold. When the battery voltage falls below the recharge threshold, the charger will automatically start another charging cycle. The charger provides various safety features for battery charging and system operations, including battery temperature monitoring based on negative temperature coefficient (NTC) thermistor, charge safety timer, input over-voltage and over-current protections, as well as battery over-voltage protection. Pin open and short protection is also built in to protect against the battery voltage feedback pin FB or feedback resistors accidentally open or short. The thermal regulation regulates charge current to limit die temperature during high power operation or high ambient temperature conditions.

The STAT pin output reports charging status and fault conditions. When the input voltage is removed, the device automatically enters HiZ mode with very low leakage current from battery to the charger device. The BQ25306 is available in a 3 mm x 3 mm thin WQFN package.

6 Device Comparison Table

	BQ25302	BQ25306
Battery Cells in Series	1 cell	1-2 cell
Input Voltage	4.1V to 6.2V	4.1V - 17V
Charge Voltage	4.1V, 4.35V, 4.4V, 4.2V	Programmable from 3.4V to 9.0V
Maximum Fast Charge Current	2.0A	3.0A
Battery Temperature Protection (JEITA or Cold/Hot)	Cold/Hot	Cold/Hot

7 Pin Configuration and Functions

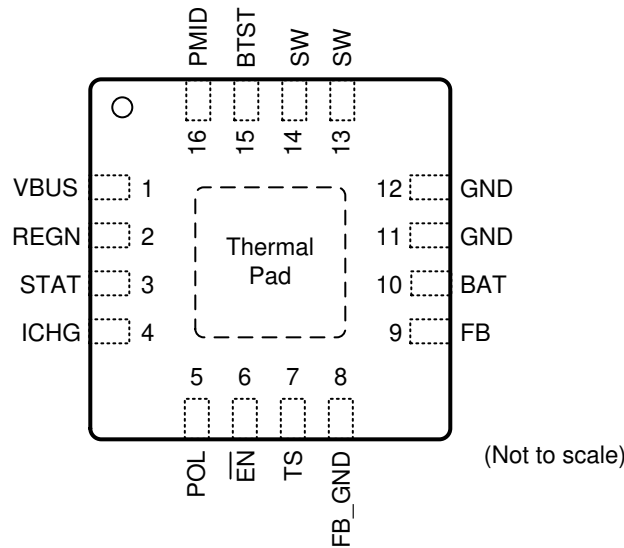

Figure 7-1. RTE Package 16-Pin WQFN Top View

Table 7-1. Pin Functions

PIN		I/O ⁽¹⁾	DESCRIPTION
NAME	NO.		
VBUS	1	P	Charger input voltage. The internal n-channel reverse block MOSFET (RBFET) is connected between VBUS and PMID with VBUS on source. Place a 2.2µF ceramic capacitor from VBUS to GND and place it as close as possible to IC.
PMID	16	P	Connected to the drain of the reverse blocking MOSFET (RBFET) and the drain of high-side MOSFET (HSFET). Place ceramic 10µF on PMID to GND and place it as close as possible to IC.
SW	13,14	P	Switching node. Connected to output inductor. Internally SW is connected to the source of the n-channel HSFET and the drain of the n-channel LSFET. Connect the 0.047µF bootstrap capacitor from SW to BTST.
BTST	15	P	High-side FET driver supply. Internally, the BTST is connected to the cathode of the internal boost-strap diode. Connect the 0.047µF bootstrap capacitor from SW to BTST.
GND	11,12	P	Ground. Connected directly to thermal pad on the top layer. A single point connection is recommended between power ground and analog ground near the IC GND pins.
REGN	2	P	Low-side FET driver positive supply output. Connect a 2.2µF ceramic capacitor from REGN to GND. The capacitor should be placed close to the IC.
BAT	10	AI	Battery voltage sensing input. Connect this pin to the positive terminal of the battery pack and the node of inductor output terminal. 10-µF capacitor is recommended to connect to this pin.
TS	7	AI	Battery temperature voltage input. Connect a negative temperature coefficient thermistor (NTC). Program temperature window with a resistor divider from REGN to TS and TS to GND. Charge suspends when TS pin voltage is out of range. When TS pin is not used, connect a 10-kΩ resistor from REGN to TS and a 10-kΩ resistor from TS to GND. It is recommended to use a 103AT-2 thermistor.
ICHG	4	AI	Charge current program input. Connect a 1% resistor R _{ICHG} from this pin to ground to program the charge current as $ICHG = K_{ICHG} / R_{ICHG}$ ($K_{ICHG} = 40,000$). No capacitor is allowed to connect at this pin. When ICHG pin is pulled to ground or left open, the charger stop switching and STAT pin starts blinking.
STAT	3	AO	Charge status indication output. This pin is open drain output. Connect this pin to REGN via a current limiting resistor and LED. The STAT pin indicates charger status as: <ul style="list-style-type: none"> Charge in progress: STAT pin is pulled LOW Charge completed, charge disabled by EN: STAT pin is OPEN Fault conditions: STAT pin blinks.
FB	9	AI	Battery voltage feedback input. Connect this pin to resistor divider's middle point to program battery charge voltage. When this pin is shorted to GND or open by fault, the converter stop switching and STAT pin blinks. The resistor divider consists of a resistor R ₁ from battery positive terminal to FB pin and a resistor R ₂ from FB pin to FB_GND. The recommended resistance value of R ₂ is 200kΩ or lower. The battery charge voltage is programmed as $VBATREG = 1.1 (1 + R_1/R_2)$. The voltage regulation loop is internally compensated and a 470pF feedforward capacitor is recommended to connect from battery to FB pin.

Table 7-1. Pin Functions (continued)

PIN		I/O ⁽¹⁾	DESCRIPTION
NAME	NO.		
FB_GND	8	AI	Battery voltage feedback ground input. Connect the feedback resistor divider's low side resistor to this pin. The input of this pin is in high impedance when adaptor is unplugged or the charger is disabled by $\overline{\text{EN}}$ pin.
POL	5	AI	$\overline{\text{EN}}$ pin polarity selection. Keep this pin floating for standalone charger.
$\overline{\text{EN}}$	6	AI	Device disable input. With POL pin floating, the device is enabled with $\overline{\text{EN}}$ pin floating or pulled low, and the device is disabled if $\overline{\text{EN}}$ pin is pulled high. With POL pin grounded, the device is enabled with $\overline{\text{EN}}$ pin pulled high, and the device is disabled with $\overline{\text{EN}}$ pin pulled low or floating.
Thermal Pad	17	-	Ground reference for the device that is also the thermal pad used to conduct heat from the device. This connection serves two purposes. The first purpose is to provide an electrical ground connection for the device. The second purpose is to provide a low thermal-impedance path from the device die to the PCB. This pad should be tied externally to a ground plane. Ground layer(s) are connected to thermal pad through vias under thermal pad.

(1) AI = Analog input, AO = Analog Output, AIO = Analog input Output, DI = Digital input, DO = Digital Output, DIO = Digital input Output, P = Power

8 Specifications

8.1 Absolute Maximum Ratings

Over operating free-air temperature range (unless otherwise noted)⁽¹⁾

PARAMETER		MIN	MAX	UNIT
Voltage Range (with respect to GND)	V _{BUS} (converter not switching)	-2	28	V
	PMID(converter not switching)	-0.3	28	V
	SW	-2 ⁽²⁾	20	V
	BTST	-0.3	25.5	V
	STAT	-0.3	5.5	V
	BAT	-0.3	11	V
	BTST to SW	-0.3	5.5	V
	ICHG	-0.3	5.5	V
	REGN	-0.3	5.5	V
	POL	-0.3	5.5	V
	/EN	-0.3	5.5	V
	TS	-0.3	5.5	V
	Voltage Range (with respect to GND)	FB	-0.3	11
FB_GND		-0.3	11	V
Output Sink Current	STAT		6	mA
	REGN		20	mA
Junction temperature	T _J	-40	150	°C
Storage temperature	T _{stg}	-65	150	°C

(1) Stresses beyond those listed under *Absolute Maximum Rating* may cause permanent damage to the device. These are stress ratings only, which do not imply functional operation of the device at these or any other conditions beyond those indicated under *Recommended Operating Condition*. Exposure to absolute-maximum-rated conditions for extended periods may affect device reliability.

(2) -3V for 10ns transient

8.2 ESD Ratings

			VALUE	UNIT
V _(ESD)	Electrostatic discharge	Human body model (HBM), per ANSI/ESDA/JEDEC JS-001, all pins ⁽¹⁾	±2000	V
		Charged device model (CDM), per JEDEC specification JESD22-C101, all pins ⁽²⁾	±250	

(1) JEDEC document JEP155 states that 500-V HBM allows safe manufacturing with a standard ESD control process.

(2) JEDEC document JEP157 states that 250-V CDM allows safe manufacturing with a standard ESD control process.

8.3 Recommended Operating Conditions

over operating free-air temperature range (unless otherwise noted)

PARAMETER		MIN	NOM	MAX	UNIT
V _{VBUS}	Input voltage	4.1		17	V
V _{BAT}	Battery voltage	3.4		9	V
I _{VBUS}	Input current			3	A
I _{SW}	Output current (SW)			3	A
T _A	Ambient temperature	-40		85	°C
L	Recommended inductance at V _{VBUS_MAX} < 6.2V		1.0		µH
L	Recommended inductance at V _{VBUS_MAX} > 6.2V		2.2		µH

8.3 Recommended Operating Conditions (continued)

over operating free-air temperature range (unless otherwise noted)

PARAMETER		MIN	NOM	MAX	UNIT
C _{VBUS}	Recommended capacitance at VBUS		2.2		μF
C _{PMID}	Recommended capacitance at PMID		10		μF
C _{BAT}	Recommended capacitance at BAT		10		μF

8.4 Thermal Information

THERMAL METRIC ⁽¹⁾		BQ2530x		UNIT
		RTE		
		16-PINS		
R _{θJA}	Junction-to-ambient thermal resistance (JEDEC ⁽¹⁾)	45.8		°C/W
R _{θJC(top)}	Junction-to-case (top) thermal resistance	48.5		°C/W
R _{θJB}	Junction-to-board thermal resistance	19.0		°C/W
Ψ _{JT}	Junction-to-top characterization parameter	1.3		°C/W
Ψ _{JB}	Junction-to-board characterization parameter	19		°C/W
R _{θJC(bot)}	Junction-to-case (bottom) thermal resistance	7.9		°C/W

(1) For more information about traditional and new thermal metrics, see the [Semiconductor and IC Package Thermal Metrics](#) application report.

8.5 Electrical Characteristics

 $V_{VBUS_UVLOZ} < V_{VBUS} < V_{VBUS_OVP}$ and $V_{VBUS} > V_{BAT} + V_{SLEEP}$, $T_J = -40^{\circ}\text{C}$ to $+125^{\circ}\text{C}$, and $T_J = 25^{\circ}\text{C}$ for typical values (unless otherwise noted)

PARAMETER		TEST CONDITIONS	MIN	TYP	MAX	UNIT
QUIESCENT CURRENT						
I _{VBUS_REVS}	VBUS reverse current from BAT/SW to VBUS, $T_J = -40^{\circ}\text{C} - 85^{\circ}\text{C}$	$V_{BAT} = V_{SW} = 4.5\text{V}$, V _{BUS} is shorted to GND, measure V _{BUS} reverse current		0.07	3	μA
I _{VBUS_REVS}	VBUS reverse current from BAT/SW to VBUS, $T_J = -40^{\circ}\text{C} - 85^{\circ}\text{C}$	$V_{BAT} = V_{SW} = 9.0\text{V}$, V _{BUS} is shorted to GND, measure V _{BUS} reverse current		0.14	6	μA
I _{Q_VBUS_DIS}	VBUS leakage current in disable mode, $T_J = -40^{\circ}\text{C} - 85^{\circ}\text{C}$	V _{BUS} = 5V, V _{BAT} = 4V, charger is disabled, /EN is pulled high		3.5	4.25	μA
I _{Q_VBUS_DIS}	VBUS leakage current in disable mode, $T_J = -40^{\circ}\text{C} - 85^{\circ}\text{C}$	V _{BUS} = 9V, V _{BAT} = 4V, charger is disabled, /EN is pulled high		4.7	6	μA
I _{Q_BAT_HIZ}	BAT and SW pin leakage current in HiZ mode, $T_J = -40^{\circ}\text{C} - 65^{\circ}\text{C}$	$V_{BAT} = V_{SW} = 4.5\text{V}$, V _{BUS} floating		0.17	1.0	μA
I _{Q_BAT_DIS_9V}	BAT and SW pin leakage current in disable mode, $T_J = -40^{\circ}\text{C} - 65^{\circ}\text{C}$	$V_{BAT} = V_{SW} = 9\text{V}$, I _{CHG} connected to a 25kΩ resistor, V _{BUS} floating		0.50	2	μA
VBUS POWER UP						
V _{VBUS_OP}	VBUS operating range		4.1		17.0	V
V _{VBUS_UVLOZ}	VBUS power on reset	V _{BUS} rising	3.0		3.80	V
V _{VBUS_UVLOZ_HYS}	VBUS power on reset hysteresis	V _{BUS} falling		250		mV
V _{VBUS_LOWV}	A condition to turnon REGN	V _{BUS} rising, REGN turns on, V _{BAT} = 3.2V	3.8	3.90	4.00	V
V _{VBUS_LOWV_HYS}	A condition to turnon REGN, hysteresis	V _{BUS} falling, REGN turns off, V _{BAT} = 3.2V		300		mV
V _{SLEEP}	Enter sleep mode threshold	V _{BUS} falling, V _{BUS} - V _{BAT} , V _{VBUS_LOWV} < V _{BAT} < V _{BATREG}	30	60	100	mV
V _{SLEEPZ}	Exit sleep mode threshold	V _{BUS} rising, V _{BUS} - V _{BAT} , V _{VBUS_LOWV} < V _{BAT} < V _{BATREG}	110	157	295	mV
V _{VBUS_OVP_RISE}	VBUS overvoltage rising threshold	V _{BUS} rising, converter stops switching	17.00	17.40	17.80	V

8.5 Electrical Characteristics (continued)

$V_{VBUS_UVLOZ} < V_{VBUS} < V_{VBUS_OVP}$ and $V_{VBUS} > V_{BAT} + V_{SLEEP}$, $T_J = -40^{\circ}\text{C}$ to $+125^{\circ}\text{C}$, and $T_J = 25^{\circ}\text{C}$ for typical values (unless otherwise noted)

PARAMETER		TEST CONDITIONS	MIN	TYP	MAX	UNIT
$V_{VBUS_OVP_HYS}$	V_{BUS} overvoltage falling hysteresis	V_{BUS} falling, converter stops switching		750		mV
MOSFETS						
R_{DSON_Q1}	Top reverse blocking MOSFET on-resistance between V_{BUS} and PMID (Q1)	$V_{REGN} = 5\text{V}$		40	65	m Ω
R_{DSON_Q2}	High-side switching MOSFET on-resistance between PMID and SW (Q2)	$V_{REGN} = 5\text{V}$		50	82	m Ω
R_{DSON_Q3}	Low-side switching MOSFET on-resistance between SW and GND (Q3)	$V_{REGN} = 5\text{V}$		45	72	m Ω
$R_{DSON_FB_GND}$	FB_GND MOSFET on-resistance between FB_GND and GND				38	Ω
BATTERY CHARGER						
V_{BATREG_RANGE}	Charge voltage regulation range	$V_{VBUS} = 12\text{V}$, V_{BATREG} is programmed by FB resistor divider	3.400		9.000	V
$V_{FB_REF_VBATREG}$	Battery feedback regulation voltage	$T_J = -40^{\circ}\text{C}$ to $+85^{\circ}\text{C}$	1094	1100	1104.5	mV
I_{CHG}	Charge current regulation	ICHG set at 1.72A with $R_{ICHG}=23.2\text{k}\Omega$	1.55	1.72	1.89	A
		ICHG set at 1.0A with $R_{ICHG}=40.2\text{k}\Omega$	0.90	1.00	1.10	A
		ICHG set at 0.5A with $R_{ICHG}=78.7\text{k}\Omega$	0.40	0.500	0.60	A
I_{TERM}	Termination current	ICHG = 1.72A, 10% of ICHG, $R_{ICHG}=23.2\text{k}\Omega$	138	172	206	mA
I_{TERM}	Termination current	ICHG = 1.0A, 10% of ICHG, $R_{ICHG}=40.2\text{k}\Omega$	70	100	130	mA
I_{TERM}	Termination current	ICHG = 0.5A, $I_{TERM} = 63\text{mA}$, $R_{ICHG}=78.7\text{k}\Omega$	33	63	93	mA
I_{PRECHG}	Precharge current	ICHG = 1.72A, 10% of ICHG, $R_{ICHG}=23.2\text{k}\Omega$	115	172	225	mA
		ICHG = 1.0A, 10% of ICHG, $R_{ICHG}=40.2\text{k}\Omega$	50	100	150	mA
		ICHG = 0.5A, 10% of ICHG, $R_{ICHG}=78.7\text{k}\Omega$	28	63	98	mA
$V_{BAT_SHORT_RISE}$	VBAT short rising threshold	Short to precharge	2.05	2.20	2.35	V
$V_{BAT_SHORT_FALL}$	VBAT short falling threshold	Precharge to battery short	1.85	2.00	2.15	V
I_{BAT_SHORT}	Battery short current	$V_{BAT} < V_{BAT_SHORT_FALL}$	25	35	46	mA
$V_{FB_REF_LOWV_RISE}$	$V_{BATLOWV}$ rising threshold	Precharge to fast charge rising, as percentage of $V_{FB_REF_VBATREG}$	68	70	72	%
$V_{FB_REF_LOWV_FALL}$	$V_{BATLOWV}$ falling threshold	Fast charge to precharge falling, as percentage of $V_{FB_REF_VBATREG}$	66	68	70	%
$V_{FB_REF_RECHG}$	Recharge threshold	V_{FB} falling, as percentage of $V_{FB_REF_VBATREG}$	95.2	96.4	97.6	%
INPUT VOLTAGE / CURRENT REGULATION						
V_{INDPM_MIN}	Minimum input voltage regulation	$V_{BAT} = 3.5\text{V}$, measured at PMID pin	4.0	4.07	4.2	V
V_{INDPM}	Input voltage regulation	$V_{BAT} = 4\text{V}$, measured at PMID pin, $V_{INDPM} = 1.044 * V_{BAT} + 0.125\text{V}$	4.15	4.30	4.41	V
V_{INDPM}	Input voltage regulation	$V_{BAT} = 8\text{V}$, measured at PMID pin, $V_{INDPM} = 1.044 * V_{BAT} + 0.125\text{V}$	8.27	8.47	8.67	V
I_{INDPM_3A}	Input current regulation		3.00	3.35	3.70	A
BATTERY OVER-VOLTAGE PROTECTION						
$V_{FB_BAT_OVP_RISE}$	Battery overvoltage rising threshold	V_{BAT} rising as percentage of $V_{FB_REF_VBATREG}$	103	104	105	%
$V_{FB_BAT_OVP_FALL}$	Battery overvoltage falling threshold	V_{BAT} falling as percentage of $V_{FB_REF_VBATREG}$	101	102	103	%
CONVERTER PROTECTION						

8.5 Electrical Characteristics (continued)

$V_{VBUS_UVLOZ} < V_{VBUS} < V_{VBUS_OVP}$ and $V_{VBUS} > V_{BAT} + V_{SLEEP}$, $T_J = -40^{\circ}\text{C}$ to $+125^{\circ}\text{C}$, and $T_J = 25^{\circ}\text{C}$ for typical values (unless otherwise noted)

PARAMETER		TEST CONDITIONS	MIN	TYP	MAX	UNIT
$V_{BTST_REFRESH}$	Bootstrap refresh comparator threshold	$(V_{BTST} - V_{SW})$ when LSFET refresh pulse is requested, $V_{BUS} = 5V$	2.7	3	3.3	V
I_{HSFET_OCP}	HSFET cycle by cycle over current limit threshold		5.2	6.2	6.7	A
STAT INDICATION						
I_{STAT_SINK}	STAT pin sink current		6			mA
F_{BLINK}	STAT pin blink frequency			1		Hz
F_{BLINK_DUTY}	STAT pin blink duty cycle			50		%
THERMAL REGULATION AND THERMAL SHUTDOWN						
T_{REG}	Junction temperature regulation accuracy		111	120	133	$^{\circ}\text{C}$
T_{SHUT}	Thermal shutdown rising threshold	Temperature increasing		150		$^{\circ}\text{C}$
	Thermal shutdown falling threshold	Temperature decreasing		125		$^{\circ}\text{C}$
BUCK MODE OPERATION						
F_{SW}	PWM switching frequency	SW node frequency	1.02	1.20	1.38	MHz
D_{MAX}	Maximum PWM Duty Cycle			97.0		%
REGN LDO						
V_{REGN_UVLO}	REGN UVLO	V_{VBUS} rising			3.85	V
V_{REGN}	REGN LDO output voltage	$V_{VBUS} = 5V$, $I_{REGN} = 0$ to 16mA	4.2		5.0	V
V_{REGN}	REGN LDO output voltage	$V_{VBUS} = 12V$, $I_{REGN} = 16mA$	4.50		5.40	V
ICHG SETTING						
V_{ICHG}	ICHG pin regulated voltage		993	998	1003	mV
$R_{ICHG_SHORT_FALL}$	Maximum resistance to disable charge				1.0	k Ω
$R_{ICHG_OPEN_RISE}$	Minimum resistance to disable charge		565			k Ω
R_{ICHG_MAX}	Maximum programmable resistance at ICHG				250	k Ω
$R_{ICHG_MIN_SLE1}$	Minimum programmable resistance at ICHG		11.70			k Ω
R_{ICHG_HIGH}	ICHG setting resistor threshold to clamp precharge and termination current to 63mA	$R_{ICHG} > R_{ICHG_HIGH}$	60	65	70	k Ω
K_{ICHG}	Charge current ratio	ICHG set at 1.72A with $R_{ICHG} = 23.2k\Omega$, $I_{CHG} = K_{ICHG} / R_{ICHG}$	36000	40000	44000	Ax Ω
K_{ICHG}	Charge current ratio	ICHG set at 1.0A with $R_{ICHG} = 40.2k\Omega$, $I_{CHG} = K_{ICHG} / R_{ICHG}$	36000	40280	44000	Ax Ω
K_{ICHG}	Charge current ratio	ICHG set at 0.5A with $R_{ICHG} = 78.7k\Omega$, $I_{CHG} = K_{ICHG} / R_{ICHG}$	32000	40700	48000	Ax Ω
COLD/HOT THERMISTOR COMPARATOR						
$V_{T1}\%$	TCOLD (0°C) threshold, charge suspended if thermistor temperature is below T1	V_{TS} rising, as percentage to V_{REGN}	72.68	73.5	74.35	%
$V_{T1}\%$	V_{TS} falling	As Percentage to V_{REGN}	70.68	71.5	72.33	%
$V_{T3}\%$	THOT (45°C) threshold, charge suspended if thermistor temperature is above T_HOT	V_{TS} falling, as percentage to V_{REGN}	46.35	47.25	48.15	%
$V_{T3}\%$	V_{TS} rising	As percentage to V_{REGN}	47.35	48.25	49.15	%

8.5 Electrical Characteristics (continued)

$V_{VBUS_UVLOZ} < V_{VBUS} < V_{VBUS_OVP}$ and $V_{VBUS} > V_{BAT} + V_{SLEEP}$, $T_J = -40^{\circ}\text{C}$ to $+125^{\circ}\text{C}$, and $T_J = 25^{\circ}\text{C}$ for typical values (unless otherwise noted)

PARAMETER		TEST CONDITIONS	MIN	TYP	MAX	UNIT
LOGIC I/O PIN CHARACTERISTICS (POL, EN)						
V_{ILO}	Input low threshold	Falling			0.40	V
V_{IH}	Input high threshold	Rising	1.3			V
I_{BIAS}	High-level leakage current at /EN pin	/EN pin is pulled up to 1.8 V		1.0		μA

8.6 Timing Requirements

PARAMETER		TEST CONDITIONS	MIN	NOM	MAX	UNIT
VBUS/BAT POWER UP						
$t_{CHG_ON_EN}$	Delay from enable at /EN pin to charger power on	/EN pin voltage rising		245		ms
$t_{CHG_ON_VBUS}$	Delay from VBUS to charge start	/EN pin is grounded, battery present		275		ms
BATTERY CHARGER						
t_{SAFETY_FAST}	Charge safety timer	Fast charge safety timer 20 hours	15.0	20.0	24.0	hr
t_{SAFETY_PRE}	Charge safety timer	Precharge safety timer	1.5	2.0	2.5	hr

8.7 Typical Characteristics

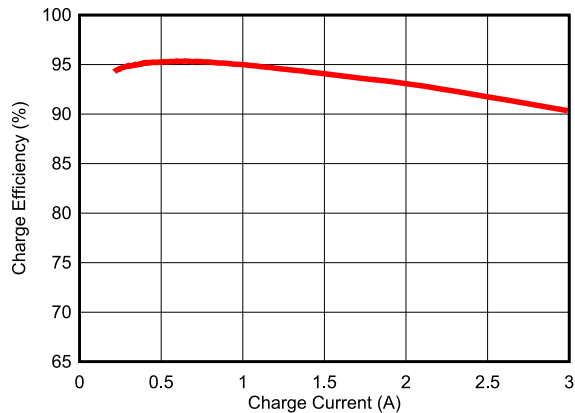

$f_{SW} = 1.2 \text{ MHz}$ Inductance = 1.0 μH
 $V_{BUS} = 5.0 \text{ V}$, $V_{BAT} = 3.8 \text{ V}$ Inductor DCR = 10 $\text{m}\Omega$

Figure 8-1. 1-Cell Battery Charge Efficiency vs. Charge Current

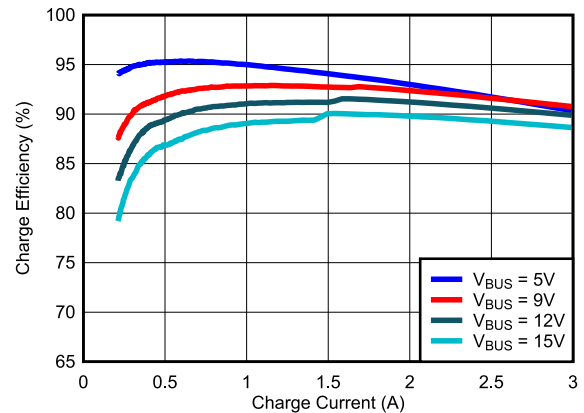

$f_{SW} = 1.2 \text{ MHz}$ Inductance = 2.2 μH
 $V_{BAT} = 3.8 \text{ V}$ Inductor DCR = 20 $\text{m}\Omega$

Figure 8-2. 1-Cell Battery Charge Efficiency vs. Charge Current

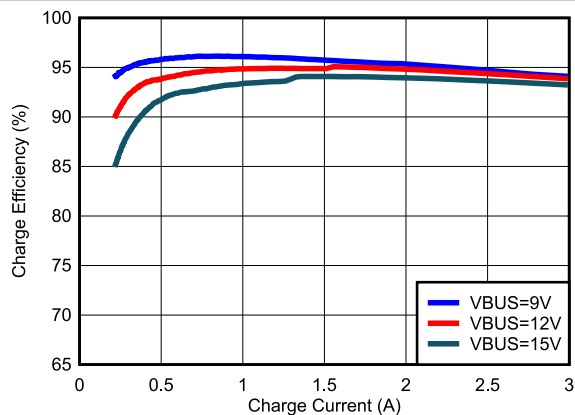

$f_{SW} = 1.2 \text{ MHz}$ Inductance = 2.2 μH
 $V_{BAT} = 7.6 \text{ V}$ Inductor DCR = 20 $\text{m}\Omega$

Figure 8-3. 2-Cell Battery Charge Efficiency vs. Charge Current

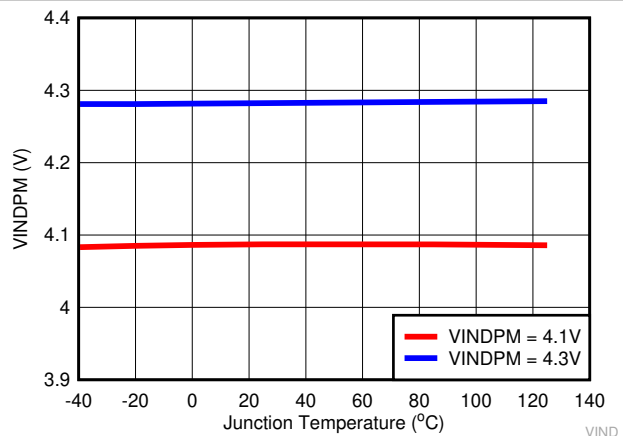

Figure 8-4. VINDPM vs. Junction Temperature

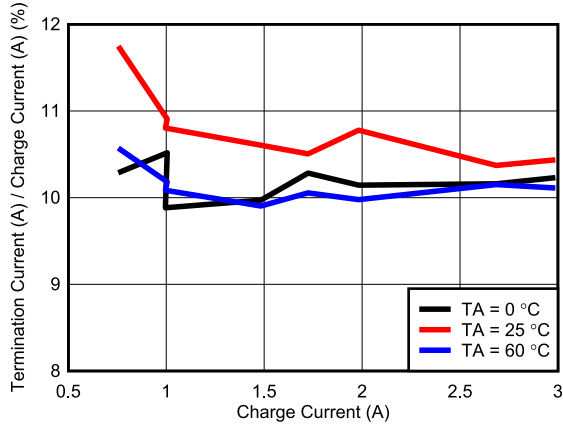

Figure 8-5. Termination Current as Percentage of Charge Current vs. Charge Current (1-cell)

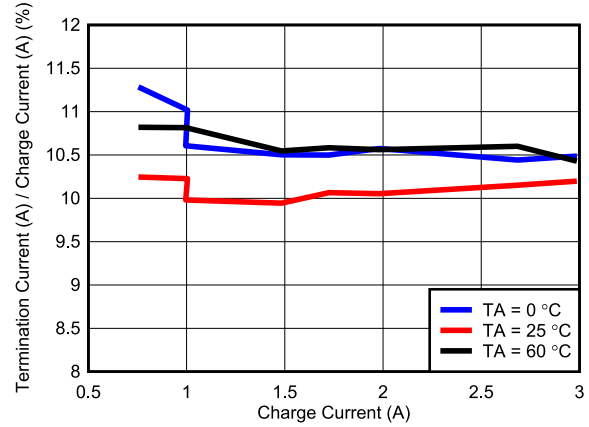

Figure 8-6. Termination Current as Percentage of Charge Current vs. Charge Current (2-cell)

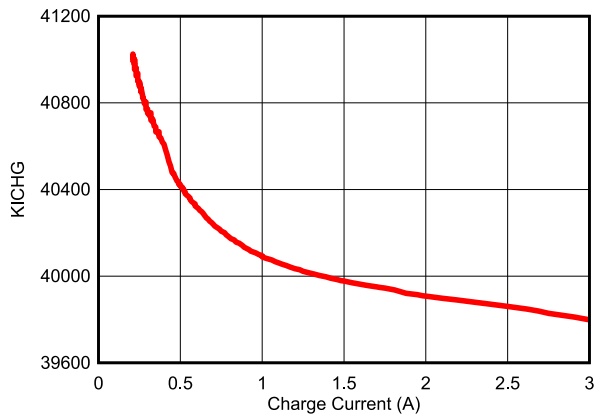

Figure 8-7. KICHG vs. Charge Current

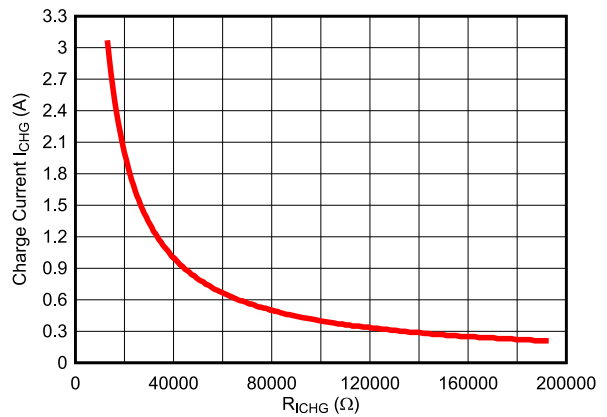

Figure 8-8. Charge Current vs. Charge Current Setting Resistance RICHG

9 Detailed Description

9.1 Overview

The BQ25306 is a highly integrated standalone single cell and dual cell Li-Ion battery charger for Li-Ion, Li-polymer and LiFePO4 batteries with charge voltage and charge current programmable by external resistors. It includes the input reverse-blocking FET (RBFET, Q1), high-side switching FET (HSFET, Q2), low-side switching FET (LSFET, Q3), bootstrap diode for the high-side gate drive as well as current sensing circuitry.

9.2 Functional Block Diagram

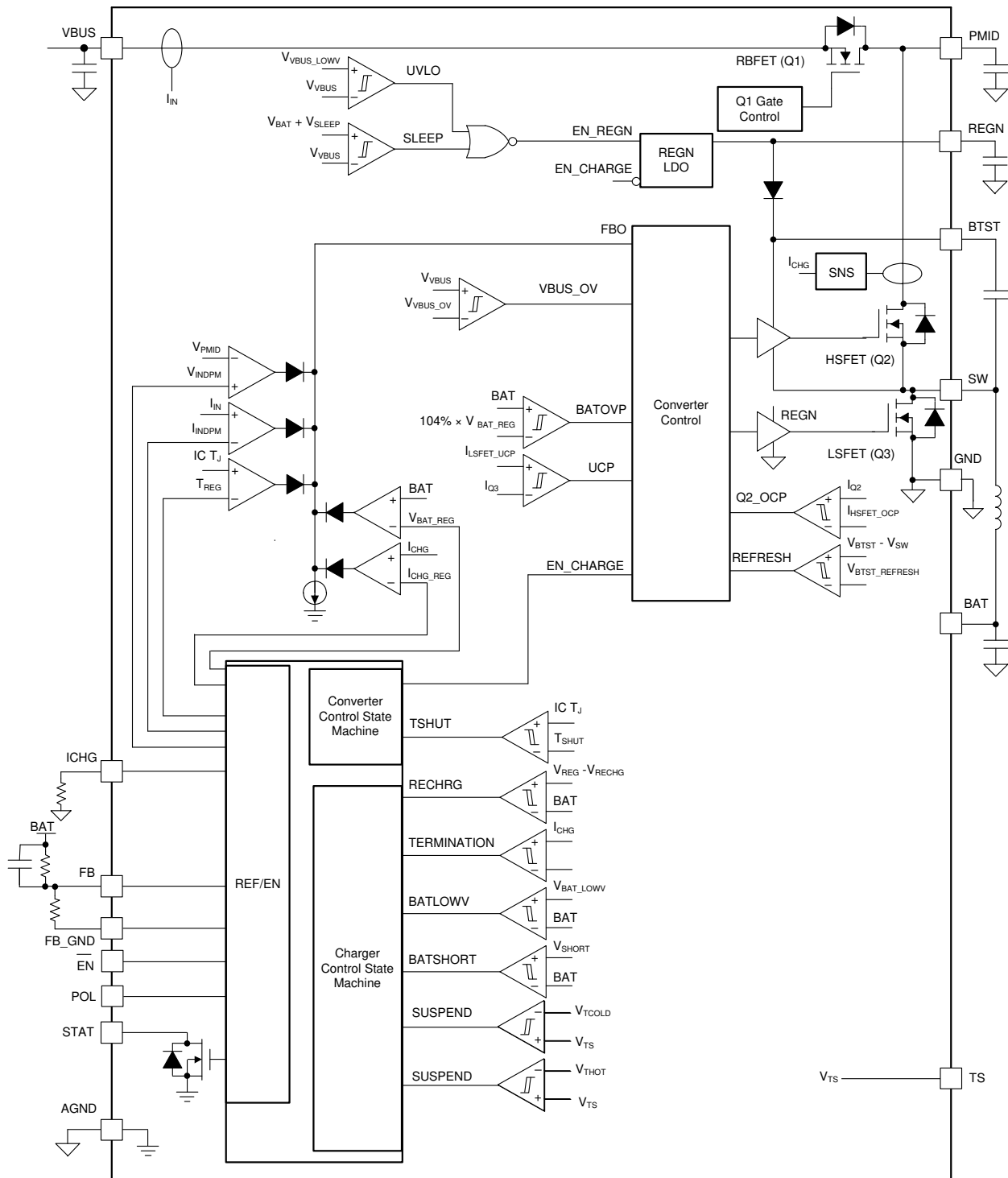

9.3 Feature Description

9.3.1 Device Power Up

The $\overline{\text{EN}}$ pin enable or disable the device. When the device is disabled, the device draws minimum current from VBUS pin. The device can be powered up from either VBUS or by enabling the device from $\overline{\text{EN}}$ pin.

9.3.1.1 Power-On-Reset (POR)

The $\overline{\text{EN}}$ pin can enable or disable the device. When the device is disabled, the device is in disable mode and it draws minimum current at VBUS. When the device is enabled, if VBUS rises above $V_{\text{VBUS_UVLOZ}}$, the device powers part of internal bias and comparators and starts Power on Reset (POR).

9.3.1.2 REGN Regulator Power Up

The internal bias circuits are powered from the input source. The REGN supplies internal bias circuits as well as the HSFET and LSFET gate drive. The REGN also provides voltage rail to STAT LED indication. The REGN is enabled when all the below conditions are valid:

- Chip is enabled by $\overline{\text{EN}}$ pin
- V_{VBUS} above $V_{\text{VBUS_UVLOZ}}$
- V_{VBUS} above $V_{\text{BAT}} + V_{\text{SLEEPZ}}$
- After sleep comparator deglitch time and REGN delay time

REGN remains on at fault conditions. REGN is powered by VBUS only and REGN is off when VBUS power is removed.

9.3.1.3 Charger Power Up

Following REGN power-up, if there is no fault conditions, the charger powers up with soft start. If there is any fault, the charger will remain off until fault is clear. Any of the fault conditions below gates charger power-up:

- $V_{\text{VBUS}} > V_{\text{VBUS_OVP}}$
- Thermistor cold/hot fault on TS pin
- $V_{\text{BAT}} > V_{\text{BAT_OVP}}$
- Safety timer fault
- FB pin is open or short to GND
- ICHG pin is open or short to GND
- Die temperature is above TSHUT

9.3.1.4 Charger Enable and Disable by $\overline{\text{EN}}$ Pin

With POL pin floating, the charger can be enabled with $\overline{\text{EN}}$ pin pulled low (or floating) or disabled by $\overline{\text{EN}}$ pin pulled high. The charger is in [disable mode](#) when disabled.

9.3.1.5 Device Unplugged from Input Source

When V_{BUS} is removed from an adaptor, the device stays in HiZ mode and the leakage current from the battery to BAT pin and SW pin is less than $I_{\text{Q_BAT_HIZ}}$.

9.3.2 Battery Charging Management

The BQ25306 charges 1-cell or 2-cell Li-Ion battery with up to 3.0-A charge current from up to 17-V input voltage. A new charge cycle starts when the charger power-up conditions are met. The charge voltage programmed by external resistor divider at FB pin and charge current are set by external resistors at ICHG pin. The charger terminates the charging cycle when the charging current is below termination threshold I_{TERM} and charge voltage is above recharge threshold, and device is not in IINDPM or thermal regulation. When a fully charged battery's voltage is discharged below recharge threshold, the device automatically starts a new charging cycle with safety timer reset. To initiate a recharge cycle, the conditions of charger power-up must be met. The STAT pin output indicates the charging status of charging (LOW), charging complete or charge disabled (HIGH) or charging faults (BLINKING).

9.3.2.1 Battery Charging Profile

The device charges the battery in four phases: battery short, preconditioning, constant current, constant voltage. The fast charge current is set by a resistor ICHG pin. The battery charging profile is shown in the figure. The device charges battery based on charge voltage set by the feedback resistor divider from BAT to FB and FB_GND.

Table 9-1. Charging Current Setting

MODE	BATTERY VOLTAGE V_{BAT}	CHARGE CURRENT	TYPICAL VALUE
Battery Short	$V_{BAT} < V_{BAT_SHORT}$	I_{BAT_SHORT}	35 mA
Precharge	$V_{BAT_SHORT} < V_{BAT} < V_{BAT_LOWV}$	I_{PRECHG}	10% of I_{CHG} ($I_{PRE} > 63mA$)
Fast Charge	$V_{BAT_LOWV} < V_{BAT}$	I_{CHG}	Set by ICHG resistor

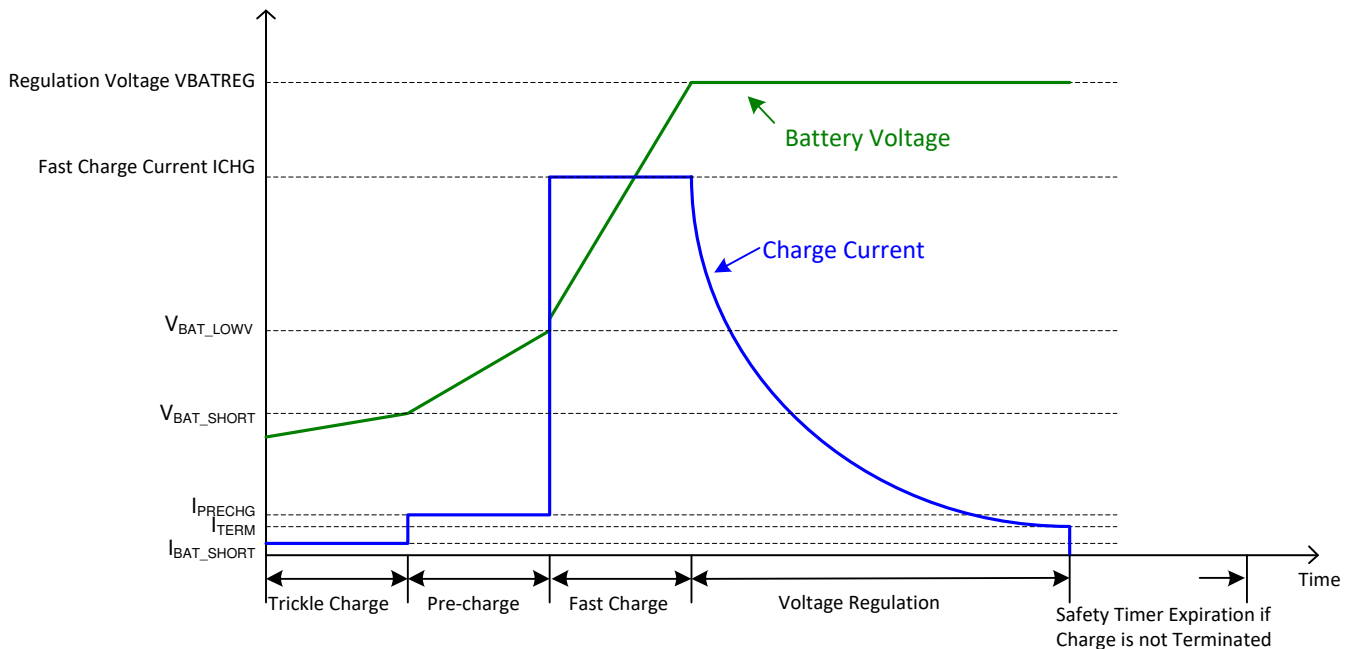

Figure 9-1. Battery Charging Profile

9.3.2.2 Precharge

The device charges the battery at 10% of set fast charge current in precharge mode. When $R_{ICHG} > R_{ICHG_HIGH}$, the precharge current is clamped at 63mA.

9.3.2.3 Charging Termination

The device terminates a charge cycle when the battery voltage is above recharge threshold and the charge current is below termination current. After a charging cycle is completed, the converter stops switching, charge is terminated and the system load is powered from battery. Termination is temporarily disabled when the charger device is in input current regulation or thermal regulation mode and the charging safety timer is counted at half the clock rate. The charge termination current is 10% of set fast charge current if $R_{ICHG} < R_{ICHG_HIGH}$. The termination current is clamped at 63mA if $R_{ICHG} > R_{ICHG_HIGH}$.

9.3.2.4 Battery Recharge

A charge cycle is completed and the charge is terminated, safety time is disabled. If the battery feedback voltage VFB decreases below $V_{FB_REF_RECHG}$, the charger is enabled with safety timer reset and enabled.

9.3.2.5 Charging Safety Timer

The device has built-in safety timer to prevent extended charging cycle due to abnormal battery conditions. The safety timer is 20 hours when the battery voltage is above V_{BAT_LOWV} threshold and 2 hours below V_{BAT_LOWV} threshold. When the safety timer expires, charge is suspended until the safety timer is reset. Safety timer is reset and charge starts under one of the following conditions:

- Battery voltage falls below recharge threshold
- VBUS voltage is recycled
- \overline{EN} pin is toggled
- Battery voltage transits across V_{BAT_SHORT} threshold
- Battery voltage transits across V_{BAT_LOWV} threshold

If the safety timer expires and the battery voltage is above recharge threshold, the charger is suspended and the STAT pin is open. If the safety timer expires and the battery voltage is below the recharge threshold, the charger is suspended and the STAT pin blinks to indicate a fault. The safety timer fault is cleared with safety timer reset.

During input current regulation, thermal regulation, the safety timer counts at half the original clock frequency and the safety timer is doubled. During TS fault, V_{BUS_OVP} , V_{BAT_OVP} , ICHG pin open and short, FB pin fault, and IC thermal shutdown faults, the safety timer is suspended. Once the fault(s) is clear, the safety timer resumes to count.

9.3.2.6 Thermistor Temperature Monitoring

The charger device provides a single thermistor input TS pin for battery temperature monitor. RT1 and RT2 programs the cold temperature T1 and hot temperature T3. In the equations, $R_{NTC,T1}$ is NTC thermistor resistance value at temperature T1 and $R_{NTC,T3}$ is NTC thermistor resistance values at temperature T3. Assuming $R_{HOT} = 0$, select 0°C to 45°C for battery charge temperature range, then NTC thermistor 103AT-2 resistance $R_{NTC,T1} = 27.28\text{ k}\Omega$ (at 0°C) and $R_{NTC,T3} = 4.91\text{ k}\Omega$ (at 45°C), from the [Equation 1](#) and [Equation 2](#), RT1 and RT2 are derived as:

- $RT1 = 4.527\text{ k}\Omega$
- $RT2 = 23.26\text{ k}\Omega$

On top of the calculation results, adding RHOT resistor can shift HOT temperature T3 up and only slightly shift up COLD temperature T1. The actual temperature T3 can be looked up in a NTC resistance table based on $(R_{NTC,T3} - R_{HOT})$ and T1 can be looked up in a NTC resistance table based on $(R_{NTC,T1} - R_{HOT})$. Because $R_{NTC,T1}$ is much higher than $R_{NTC,T3}$, RHOT can adjust HOT temperature significantly with minimal affect on COLD temperature. RHOT is optional.

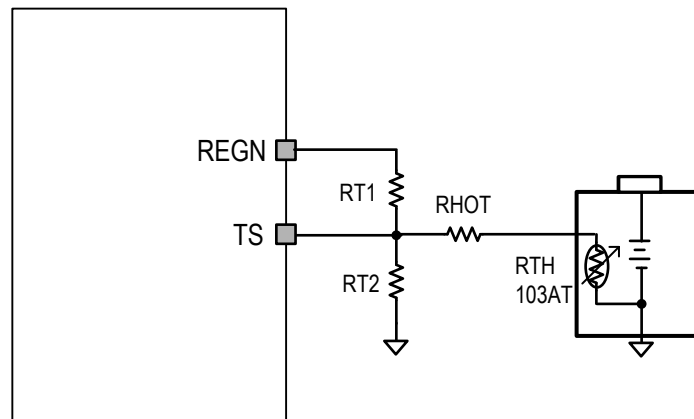

Figure 9-2. Battery Temperature Sensing Circuit

$$RT2 = \frac{R_{NTC,T1} \times R_{NTC,T3} \times \left(\frac{1}{V_{T3\%}} - \frac{1}{V_{T1\%}} \right)}{R_{NTC,T1} \times \left(\frac{1}{V_{T1\%}} - 1 \right) - R_{NTC,T3} \times \left(\frac{1}{V_{T3\%}} - 1 \right)} \quad (1)$$

$$RT1 = \frac{\frac{1}{V_{T1\%}} - 1}{\frac{1}{R_{T2}} + \frac{1}{R_{NTC,T1}}} \quad (2)$$

9.3.3 Charging Status Indicator (STAT)

The device indicates charging state on the open drain STAT pin. The STAT pin can drive a LED that is pulled up to REGN rail through a current limit resistor.

Table 9-2. STAT Pin State

CHARGING STATE	STAT INDICATOR
Charging in progress (including recharge)	LOW
Charging complete	HIGH
HiZ mode, sleep mode, charge disable	HIGH
Safety timer expiration with battery voltage above recharge threshold	HIGH
Charge faults: 1. VBUS input over voltage 2. TS cold/hot faults 3. Battery over voltage 4. IC thermal shutdown 5. Safety timer expiration with battery voltage below recharge threshold 6. ICHG pin open or short 7. FB pin open or short	BLINKING at 1 Hz with 50% duty cycle

9.3.4 Protections

9.3.4.1 Voltage and Current Monitoring

The device closely monitors the input voltage and input current for safe operation.

9.3.4.1.1 Input Over-Voltage Protection

This device integrates the functionality of an input over-voltage protection (OVP). The input OVP threshold is $V_{VBUS_OVP_RISE}$. During an input over-voltage event, the converter stops switching and safety timer stops counting as well. The converter resumes switching and the safety timer resumes counting once the VBUS voltage drops back below $(V_{VBUS_OVP_RISE} - V_{VBUS_OVP_HYS})$. The REGN LDO remains on during an input over-voltage event. The STAT pin blinks during an input OVP event.

9.3.4.1.2 Input Voltage Dynamic Power Management (VINDPM)

When the input current of the device exceeds the current capability of the power supply, the charger device regulates PMID voltage by reducing charge current to avoid crashing the input power supply. VINDPM dynamically tracks the battery voltage. The actual VINDPM is the higher of V_{INDPM_MIN} and $(1.044 \cdot VBAT + 125mV)$.

9.3.4.1.3 Input Current Limit

The device has built-in input current limit. When the input current is over the threshold I_{INDPM} , the converter duty cycle is reduced to reduce input current.

9.3.4.1.4 Cycle-by-Cycle Current Limit

High-side (HS) FET current is cycle-by-cycle limited. Once the HSFET peak current hits the limit I_{HSFET_OCP} , the HSFET shuts down until the current is reduced below a threshold.

9.3.4.2 Thermal Regulation and Thermal Shutdown

The device monitors the junction temperature T_J to avoid overheating the chip and limit the device surface temperature. When the internal junction temperature exceeds thermal regulation limit T_{REG} , the device lowers down the charge current. During thermal regulation, the average charging current is usually below the programmed battery charging current. Therefore, termination is disabled and the safety timer runs at half the clock rate.

Additionally, the device has thermal shutdown built in to turn off the charger when device junction temperature exceeds T_{SHUT} rising threshold. The charger is reenabled when the junction temperature is below T_{SHUT} falling threshold. During thermal shutdown, the safety timer stops counting and it resumes when the temperature drops below the threshold.

9.3.4.3 Battery Protection

9.3.4.3.1 Battery Over-Voltage Protection (V_{BAT_OVP})

The battery voltage is clamped at above the battery regulation voltage. When the battery voltage is over $V_{BAT_OVP_RISE}$, the converter stops switching until the battery voltage is below the falling threshold. During a battery over-voltage event, the safety timer stops counting and STAT pin reports the fault and it resumes once the battery voltage falls below the falling threshold. A 7-mA pull-down current is on the BAT pin once BAT_OVP is triggered. BAT_OVP may be triggered in charging mode, termination mode, and fault mode.

9.3.4.3.2 Battery Short Circuit Protection

When the battery voltage falls below the V_{BAT_SHORT} threshold, the charge current is reduced to I_{BAT_SHORT} .

9.3.4.4 ICHG Pin Open and Short Protection

To protect against ICHG pin is short or open, the charger immediately shuts off once ICHG pin is open or short to GND and STAT pin blinks to report the fault. At powerup, if ICHG pin is detected open or short to GND, the charge will not power up until the fault is clear.

9.4 Device Functional Modes

9.4.1 Disable Mode, HiZ Mode, Sleep Mode, Charge Mode, Termination Mode, and Fault Mode

The device operates in different modes depending on VBUS voltage, battery voltage, and \overline{EN} pin, POL pin, ICHG pin and FB pin connection. The functional modes are listed in the following table.

Table 9-3. Device Functional Modes

MODE	CONDITIONS	REGN LDO	CHARGE ENABLED	STAT PIN
Disable Mode	Device is disabled, POL floating, $\overline{EN} = 1$	OFF	NO	OPEN
HiZ Mode	Device is enabled and $V_{VBUS} < V_{VBUS_UVLOZ}$	OFF	NO	OPEN
Sleep Mode	Device is enabled and $V_{VBUS} > V_{VBUS_UVLOZ}$ and $V_{VBUS} < V_{BAT} + V_{SLEEPZ}$	OFF	NO	OPEN
Charge Mode	Device is enabled, $V_{VBUS} > V_{VBUS_LOWV}$ and $V_{VBUS} > V_{BAT} + V_{SLEEPZ}$, no faults, charge is not terminated	ON	YES	SHORT to GND
Charge Termination Mode	$V_{VBUS} > V_{VBUS_LOWV}$ and $V_{VBUS} > V_{BAT} + V_{SLEEPZ}$ and device is enabled, no faults, charge is terminated	ON	NO	OPEN
Fault Mode	V_{BUS_OVP} , TS cold/hot, V_{BAT_OVP} , IC thermal shutdown, safety timer fault, ICHG pin open or short, FB pin open or short	ON	NO	BLINKING

10 Application and Implementation

Note

Information in the following applications sections is not part of the TI component specification, and TI does not warrant its accuracy or completeness. TI's customers are responsible for determining suitability of components for their purposes. Customers should validate and test their design implementation to confirm system functionality.

10.1 Application Information

A typical application consists of a single cell or dual cell battery charger for Li-Ion, Li-polymer and LiFePO4 batteries used in a wide range of portable devices and accessories. It integrates an input reverse-block FET (RBFET, Q1), high-side switching FET (HSFET, Q2), and low-side switching FET (LSFET, Q3). The Buck converter output is connected to the battery directly to charge the battery and power system loads. The device also integrates a bootstrap diode for high-side gate drive.

10.2 Typical Applications

The typical applications in this section include a standalone charger without power path, a standalone charger with external power path, and a typical application with MCU programmed charge current.

10.2.1 Typical Application

The typical application in this section includes a standalone charger without power path.

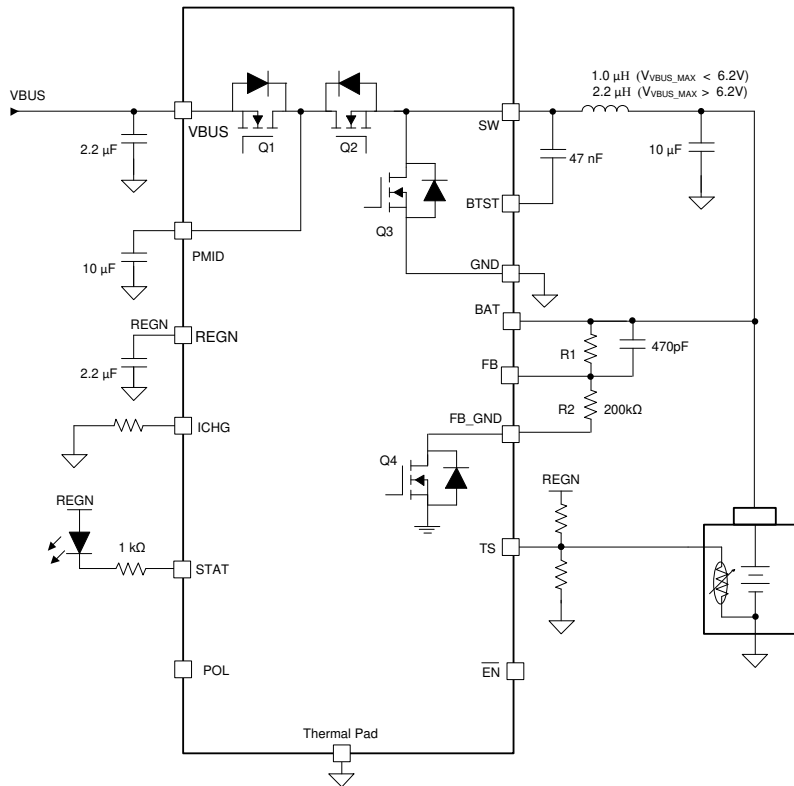

Figure 10-1. Typical Application Diagram

(1- μ H inductor is recommended if maximum input voltage $V_{VBUS_MAX} < 6.2V$; 2.2- μ H inductor is recommended if maximum input voltage $V_{VBUS_MAX} > 6.2V$)

10.2.1.1 Design Requirements

Table 10-1. Design Requirements

PARAMETER	VALUE
Input Voltage	4.1V to 17V
Input Current	3.0A
Fast Charge Current	3.0A
Battery Regulation Voltage	3.4 V – 9.0 V

10.2.1.2 Detailed Design Procedure

10.2.1.2.1 Charge Voltage Settings

Battery charge voltage is set by a resistor divider. The battery charge voltage is programmed as $V_{REG} = 1.1(1+R1/R2)$. R1 is a high side resistor from BAT to FB pin and R2 is a low side resistor from FB to FB_GND. The recommended resistance of R2 is 200 k Ω or lower. 1% or higher accuracy of resistors is needed for R1 and R2 resistors. For a 1-cell 4.2-V battery, R1 = 562 k Ω and R2 = 200 k Ω are recommended; For a 2-cell 8.4-V battery, R1 = 1.33M Ω and R2 = 200 k Ω are recommended.

10.2.1.2.2 Charge Current Setting

The charger current is set by the resistor value at the ICHG pin according to the equation below:

$$I_{CHG} (A) = K_{ICHG} (A \cdot \Omega) / R_{ICHG} (\Omega)$$

K_{ICHG} is a coefficient that is listed in Electrical Characteristics table and R_{ICHG} is the resistor value from ICHG pin to GND. K_{ICHG} is typically 40,000 (A·Ω) and it is slightly shifted up at lower charge current setting. The K_{ICHG} vs. ICHG typical characteresitc curve is shown in [Figure 8-7](#).

10.2.1.2.3 Inductor Selection

The 1.2-MHz switching frequency allows the use of small inductor and capacitor values. Inductance value is selected based on maximum input voltage V_{VBUS_MAX} in applications. 1-μH inductor is recommended if $V_{VBUS_MAX} < 6.2V$ and 2.2-μH inductor is recommended if $V_{VBUS_MAX} > 6.2V$ for either 1-cell or 2-cell battery charge. An inductor saturation current I_{SAT} should be higher than the charging curren I_{CHG} plus half the ripple current I_{RIPPLE} :

$$I_{SAT} \geq I_{CHG} + (1/2) I_{RIPPLE} \quad (3)$$

The inductor ripple current I_{RIPPLE} depends on the input voltage (V_{VBUS}), the duty cycle ($D = V_{BAT}/V_{VBUS}$), the switching frequency (f_s) and the inductance (L).

$$I_{RIPPLE} = \frac{V_{IN} \times D \times (1 - D)}{f_s \times L} \quad (4)$$

The maximum inductor ripple current occurs when the duty cycle (D) is 0.5 or approximately 0.5.

10.2.1.2.4 Input Capacitor

Design input capacitance to provide enough ripple current rating to absorb the input switching ripple current. Worst case RMS ripple current is half of the charging current when the duty cycle is 0.5. If the converter does not operate at 50% duty cycle, then the worst case capacitor RMS current I_{CIN} occurs where the duty cycle is closest to 50% and can be estimated using [Equation 5](#).

$$I_{CIN} = I_{CHG} \times \sqrt{D \times (1 - D)} \quad (5)$$

A low ESR ceramic capacitor such as X7R or X5R is preferred for the input decoupling capacitor and should be placed as close as possible to the drain of the high-side MOSFET and source of the low-side MOSFET. The voltage rating of the capacitor must be higher than the normal input voltage level. A rating of 25-V or higher capacitor is preferred for 15-V input voltage.

10.2.1.2.5 Output Capacitor

Ensure that the output capacitance has enough ripple current rating to absorb the output switching ripple current. The equation below shows the output capacitor RMS current I_{COUT} calculation.

$$I_{COUT} = \frac{I_{RIPPLE}}{2 \times \sqrt{3}} \approx 0.29 \times I_{RIPPLE} \quad (6)$$

The output capacitor voltage ripple can be calculated as follows:

$$\Delta V_O = \frac{V_{OUT}}{8LCf_s^2} \left(1 - \frac{V_{OUT}}{V_{IN}} \right) \quad (7)$$

At certain input and output voltage and switching frequency, the voltage ripple can be reduced by increasing the output filter LC.

10.2.1.3 Application Curves

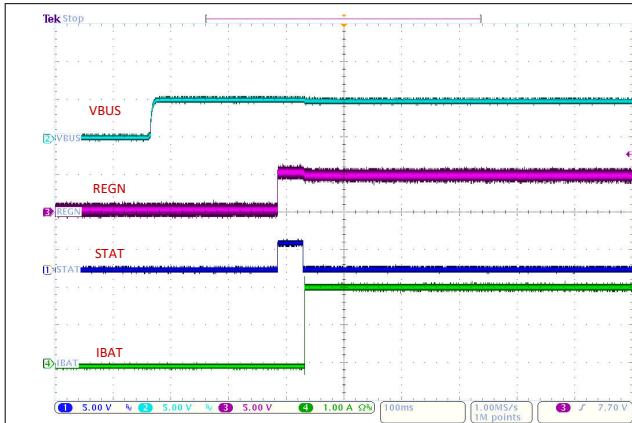

VBUS = 5 V
 ICHG = 2 A
 Device Enabled

Figure 10-2. Power Up from VBUS

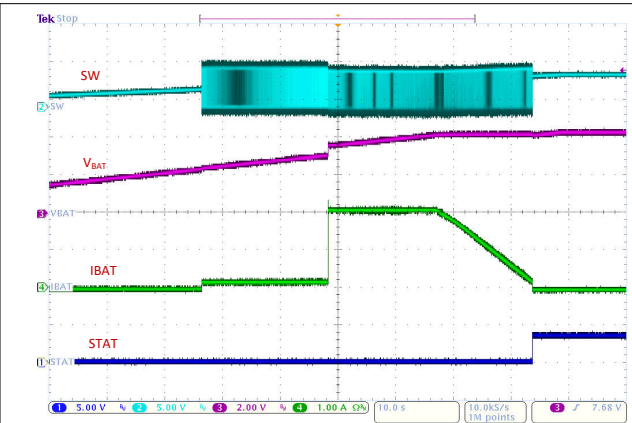

VBUS = 5 V
 ICHG = 2 A
 VBAT = 1.5V - 4.2V
 VBATREG = 4.2V

Figure 10-3. Charge Cycle

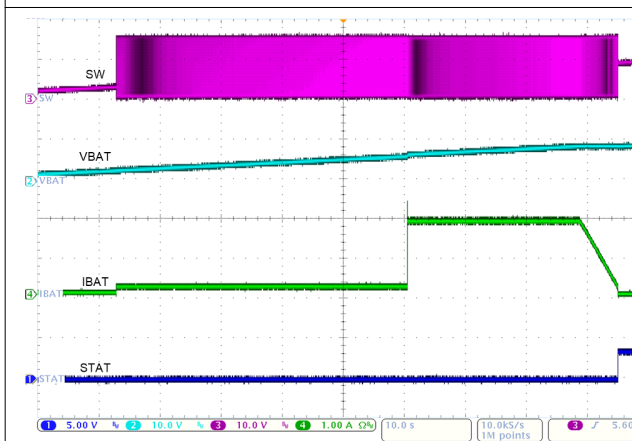

VBUS = 15 V
 ICHG = 2 A
 VBAT = 1.5V - 8.8V
 VBATREG = 8.4V

Figure 10-4. Charge Cycle

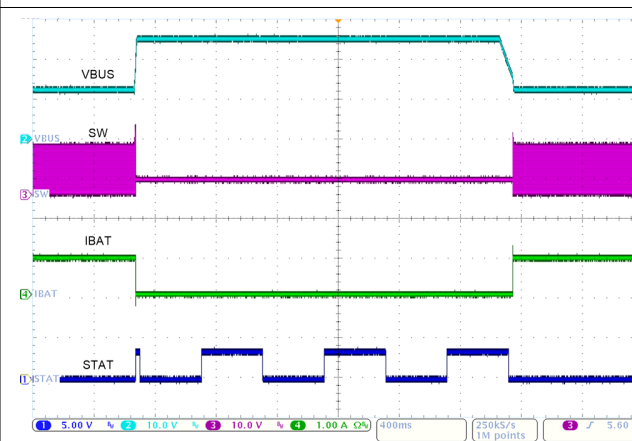

VBUS = 12V -25V -12V
 ICHG = 1A
 VBAT = 3.8V

Figure 10-5. VBUS Over Voltage Protection

BQ25306

SLUSDC7A – MARCH 2020 – REVISED NOVEMBER 2020

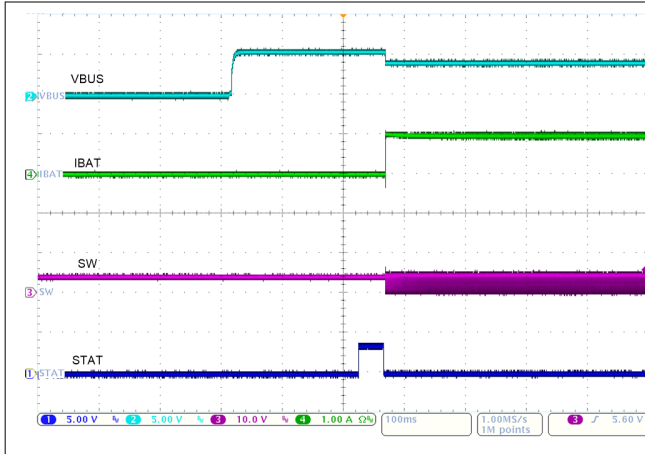

VBUS = 5 V Adaptor Current Limit: 1A
 ICHG = 2A VBAT = 3.5V

Figure 10-6. VBUS startup into VINDPM

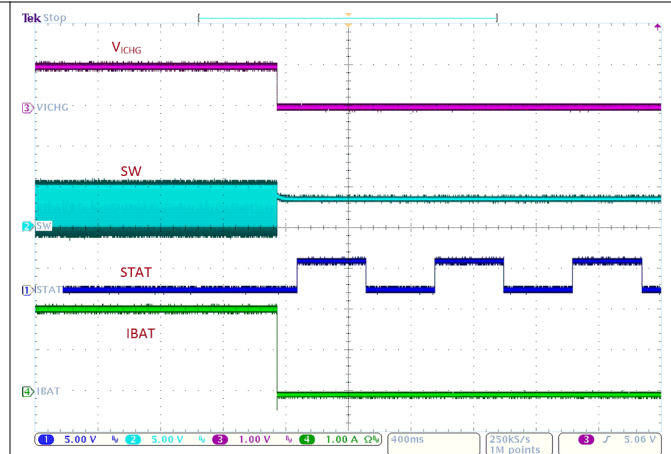

VBUS = 5 V From ICHG = 2A to ICHG pin
 short

Figure 10-7. ICHG Pin Short Circuit Protection

10.2.2 Typical Application with External Power Path

In the case where a system needs to be immediately powered up from VBUS when the battery is overdischarged or dead, the application circuit shown in Figure 10-8 can be used to provide a power path from VBUS/PMID to VSYS. PFET Q4 is an external PFET that turns on to supply VSYS from the battery when VBUS is removed; PFET Q4 turns off when VBUS is plugged in and VSYS is supplied from VBUS/PMID.

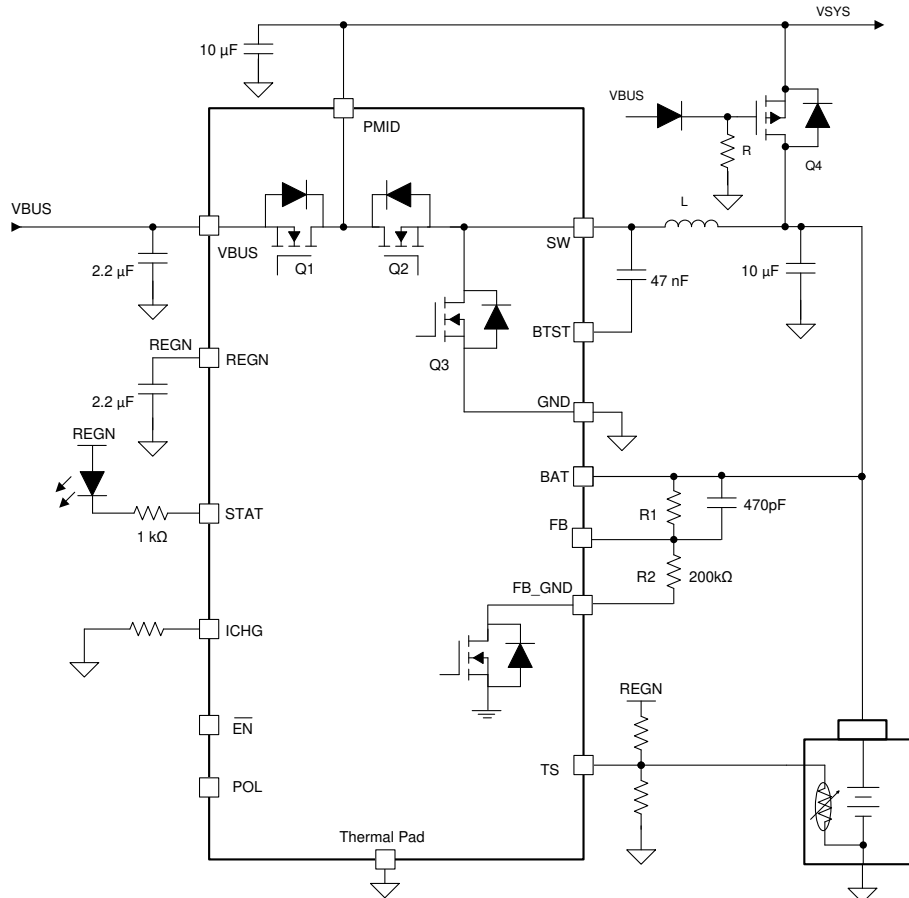

Figure 10-8. Typical Application Diagram with Power Path
 (1- μ H inductor is recommended if maximum input voltage $V_{VBUS_MAX} < 6.2V$; 2.2- μ H inductor is recommended if maximum input voltage $V_{VBUS_MAX} > 6.2V$)

10.2.2.1 Design Requirements

For design requirements, see [Section 10.2.1.1](#).

10.2.3 Typical Application with MCU Programmable Charge Current

In some application cases, the charge current needs to be controlled by a MCU. In those cases, the GPIOs of the MCU can be used for on/off control of the charge current setting resistors R_{ICHG1} and R_{ICHG2} as shown in Figure 10-9. With GPIO1 and GPIO2 on/off control, three levels of charge current can be programmed. If the charge current needs to be controlled smoothly in a wide range, a PWM output of the MCU can be used to generate an average DC voltage output to program the charge current as show in Figure 10-10. The charge current can be calculated as: $(1V - V_{\text{PWM}}) / (R_{\text{ICHG1}} + R_{\text{ICHG2}})$. V_{PWM} is the averaged DC voltage of the PWM output and it must be lower than 1 V. The regulated voltage at the ICHG pin is 1 V.

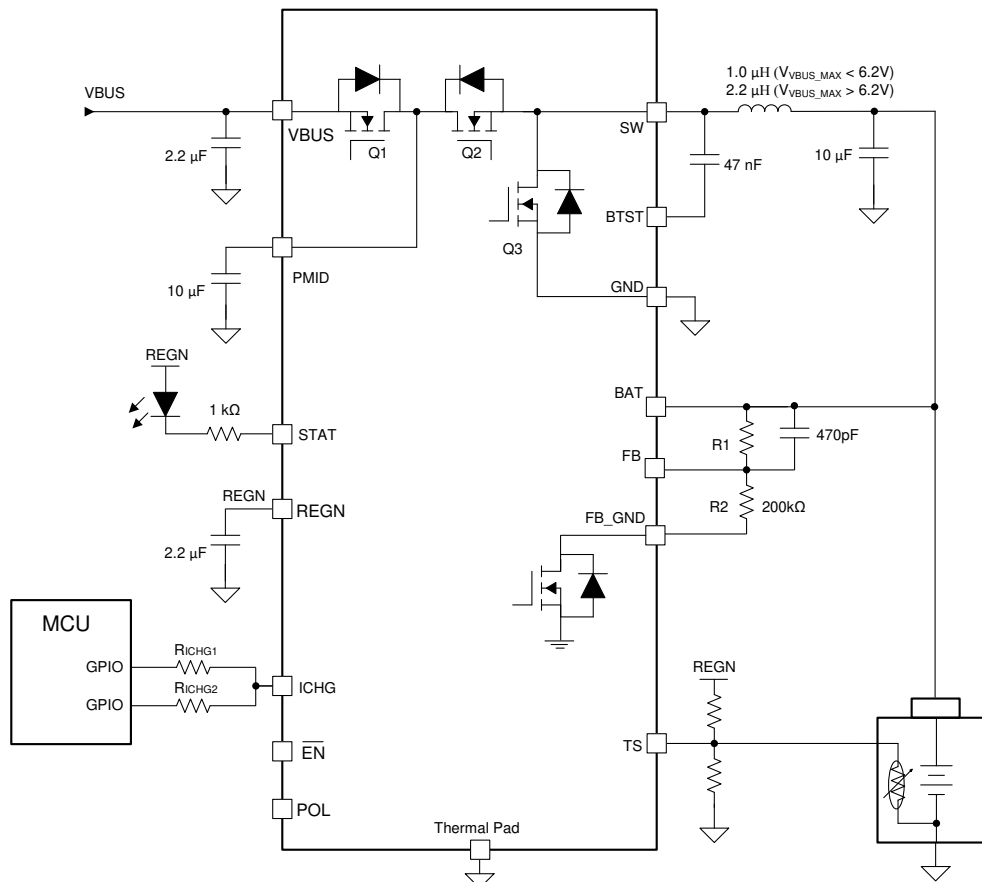

Figure 10-9. Typical Application with MCU Programmed Charge Current
(1-µH inductor is recommended if maximum input voltage $V_{\text{VBUS_MAX}} < 6.2\text{V}$; 2.2-µH inductor is recommended if maximum input voltage $V_{\text{VBUS_MAX}} > 6.2\text{V}$)

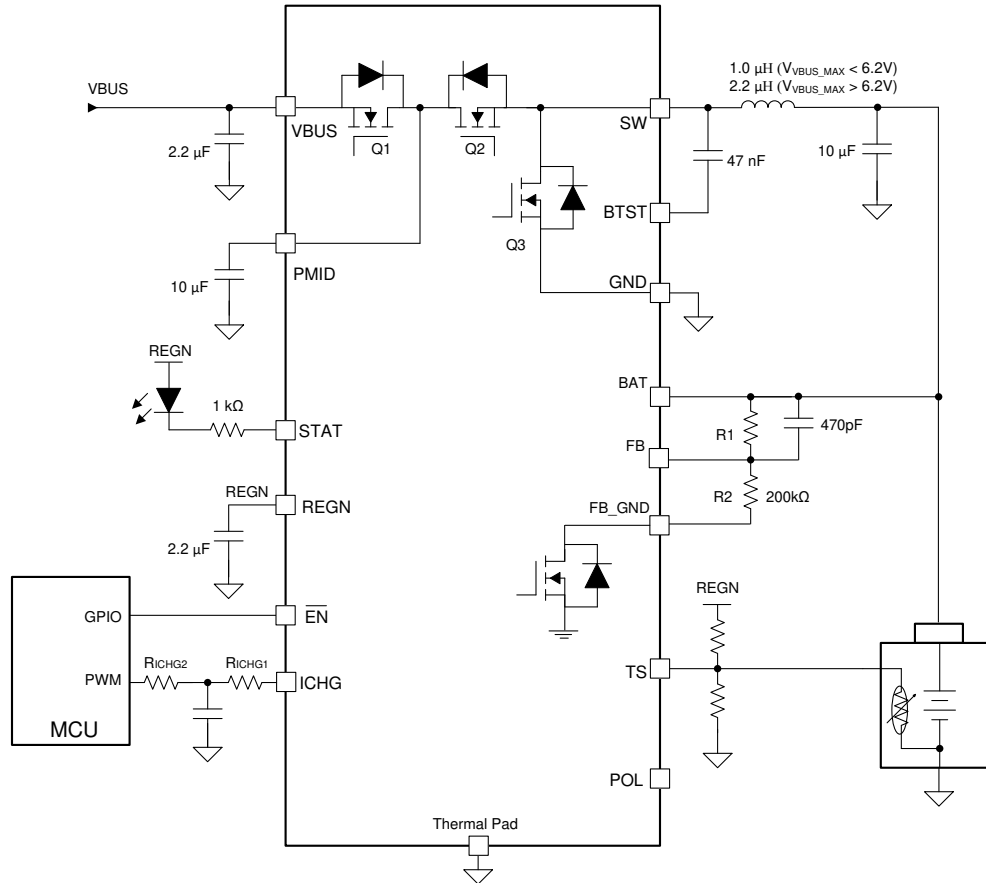

Figure 10-10. Typical Application with MCU Programmed Charge Current
 (1-µH inductor is recommended if maximum input voltage $V_{VBUS_MAX} < 6.2V$; 2.2-µH inductor is recommended if maximum input voltage $V_{VBUS_MAX} > 6.2V$)

10.2.3.1 Design Requirements

For design requirements, see [Section 10.2.1.1](#).

11 Power Supply Recommendations

In order to provide an output voltage on the BAT pin, the device requires a power supply between 4.1 V and 17 V single-cell or dual-cell Li-Ion battery with positive terminal connected to BAT. The source current rating needs to be at least 3 A in order for the buck converter to provide maximum output power to BAT or the system connected to BAT pin.

12 Layout

12.1 Layout Guidelines

The switching node rise and fall times should be minimized for minimum switching loss. Proper layout of the components to minimize high frequency current path loop (see [Figure 12-1](#)) is important to prevent electrical and magnetic field radiation and high frequency resonant problems. Follow this specific order carefully to achieve the proper layout.

- Place input capacitor as close as possible to PMID pin and use shortest thick copper trace to connect input capacitor to PMID pin and GND plane.
- It is critical that the exposed thermal pad on the backside of the device be soldered to the PCB ground. Ensure that there are sufficient thermal vias directly under the IC, connecting to the ground plane on the other layers. Connect the GND pins to thermal pad on the top layer.
- Put output capacitor near to the inductor output terminal and the charger device. Ground connections need to be tied to the IC ground with a short copper trace or GND plane
- Place inductor input terminal to SW pin as close as possible and limit SW node copper area to lower electrical and magnetic field radiation. Do not use multiple layers in parallel for this connection. Minimize parasitic capacitance from this area to any other trace or plane.
- Route analog ground separately from power ground if possible. Connect analog ground and power ground together using thermal pad as the single ground connection point under the charger device. It is acceptable to connect all grounds to a single ground plane if multiple ground planes are not available.
- Decoupling capacitors should be placed next to the device pins and make trace connection as short as possible.
- For high input voltage and high charge current applications, sufficient copper area on GND should be budgeted to dissipate heat from power losses.
- Ensure that the number and sizes of vias allow enough copper for a given current path
- See the 2 layer PCB design example in [Figure 12-2](#) for the recommended component placement with trace, grounding and via locations.

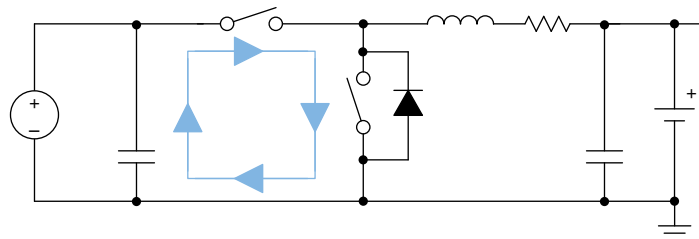

Figure 12-1. High Frequency Current Path

12.2 Layout Example

The device pinout and component count are optimized for a 2 layer PCB design. The 2-layer PCB layout example is shown in [Figure 12-2](#).

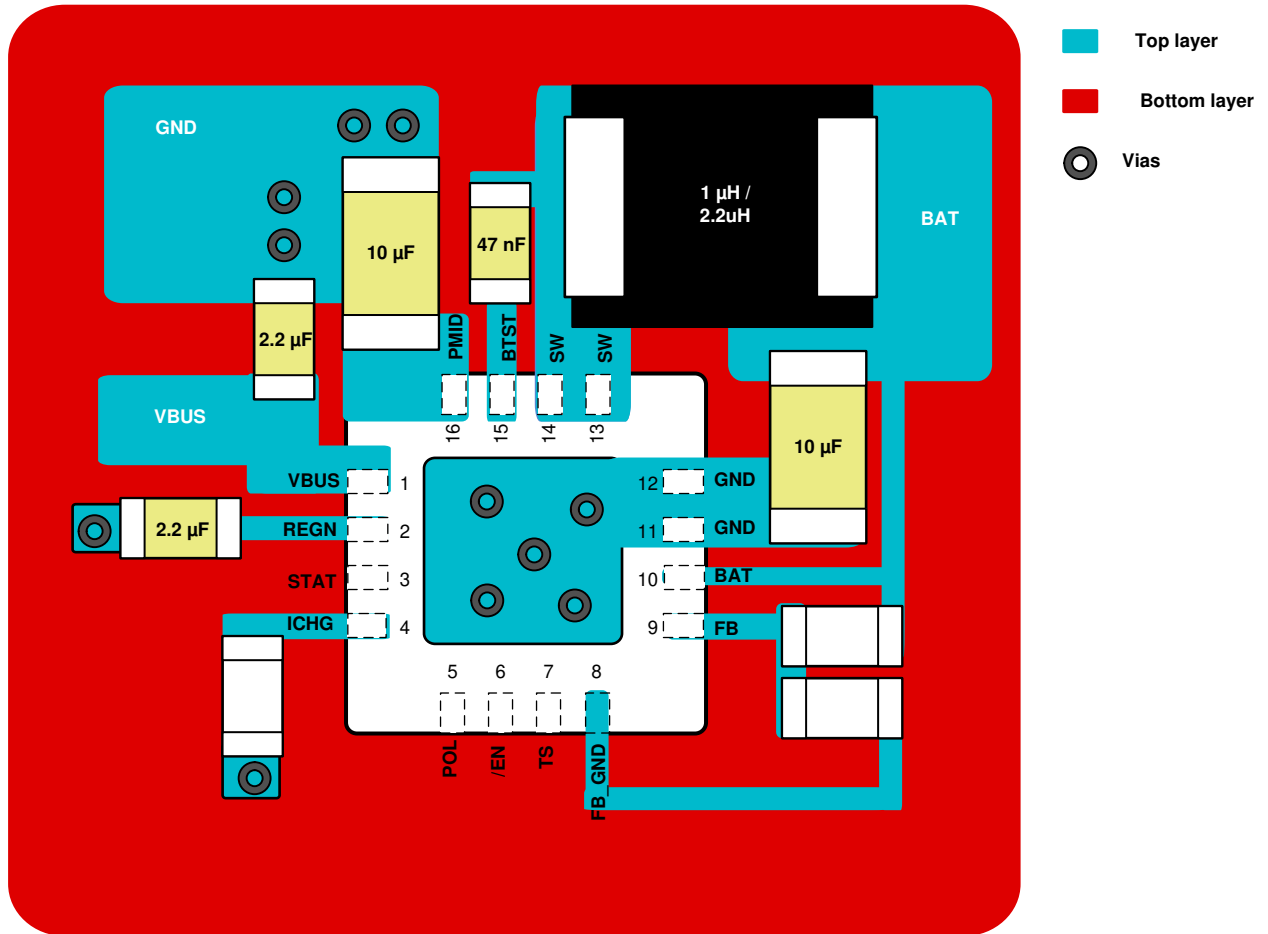

Figure 12-2. Layout Example

13 Device and Documentation Support

13.1 Device Support

13.1.1 Third-Party Products Disclaimer

TI'S PUBLICATION OF INFORMATION REGARDING THIRD-PARTY PRODUCTS OR SERVICES DOES NOT CONSTITUTE AN ENDORSEMENT REGARDING THE SUITABILITY OF SUCH PRODUCTS OR SERVICES OR A WARRANTY, REPRESENTATION OR ENDORSEMENT OF SUCH PRODUCTS OR SERVICES, EITHER ALONE OR IN COMBINATION WITH ANY TI PRODUCT OR SERVICE.

13.2 Documentation Support

13.2.1 Related Documentation

For related documentation see the following: [BQ25306 Evaluation Module User's Guide](#)

13.3 Receiving Notification of Documentation Updates

To receive notification of documentation updates, navigate to the device product folder on [ti.com](#). Click on *Subscribe to updates* to register and receive a weekly digest of any product information that has changed. For change details, review the revision history included in any revised document.

13.4 Support Resources

[TI E2E™ support forums](#) are an engineer's go-to source for fast, verified answers and design help — straight from the experts. Search existing answers or ask your own question to get the quick design help you need.

Linked content is provided "AS IS" by the respective contributors. They do not constitute TI specifications and do not necessarily reflect TI's views; see TI's [Terms of Use](#).

13.5 Trademarks

TI E2E™ is a trademark of Texas Instruments.
All trademarks are the property of their respective owners.

13.6 Electrostatic Discharge Caution



This integrated circuit can be damaged by ESD. Texas Instruments recommends that all integrated circuits be handled with appropriate precautions. Failure to observe proper handling and installation procedures can cause damage.

ESD damage can range from subtle performance degradation to complete device failure. Precision integrated circuits may be more susceptible to damage because very small parametric changes could cause the device not to meet its published specifications.

13.7 Glossary

[TI Glossary](#) This glossary lists and explains terms, acronyms, and definitions.

14 Mechanical, Packaging, and Orderable Information

The following pages include mechanical, packaging, and orderable information. This information is the most current data available for the designated devices. This data is subject to change without notice and revision of this document. For browser-based versions of this data sheet, refer to the left-hand navigation.

PACKAGING INFORMATION

Orderable Device	Status (1)	Package Type	Package Drawing	Pins	Package Qty	Eco Plan (2)	Lead finish/ Ball material (6)	MSL Peak Temp (3)	Op Temp (°C)	Device Marking (4/5)	Samples
BQ25306RTER	ACTIVE	WQFN	RTE	16	3000	RoHS & Green	NIPDAU	Level-1-260C-UNLIM	-40 to 85	B25306	Samples

(1) The marketing status values are defined as follows:

ACTIVE: Product device recommended for new designs.

LIFEBUY: TI has announced that the device will be discontinued, and a lifetime-buy period is in effect.

NRND: Not recommended for new designs. Device is in production to support existing customers, but TI does not recommend using this part in a new design.

PREVIEW: Device has been announced but is not in production. Samples may or may not be available.

OBSOLETE: TI has discontinued the production of the device.

(2) **RoHS:** TI defines "RoHS" to mean semiconductor products that are compliant with the current EU RoHS requirements for all 10 RoHS substances, including the requirement that RoHS substance do not exceed 0.1% by weight in homogeneous materials. Where designed to be soldered at high temperatures, "RoHS" products are suitable for use in specified lead-free processes. TI may reference these types of products as "Pb-Free".

RoHS Exempt: TI defines "RoHS Exempt" to mean products that contain lead but are compliant with EU RoHS pursuant to a specific EU RoHS exemption.

Green: TI defines "Green" to mean the content of Chlorine (Cl) and Bromine (Br) based flame retardants meet JS709B low halogen requirements of <=1000ppm threshold. Antimony trioxide based flame retardants must also meet the <=1000ppm threshold requirement.

(3) MSL, Peak Temp. - The Moisture Sensitivity Level rating according to the JEDEC industry standard classifications, and peak solder temperature.

(4) There may be additional marking, which relates to the logo, the lot trace code information, or the environmental category on the device.

(5) Multiple Device Markings will be inside parentheses. Only one Device Marking contained in parentheses and separated by a "~" will appear on a device. If a line is indented then it is a continuation of the previous line and the two combined represent the entire Device Marking for that device.

(6) Lead finish/Ball material - Orderable Devices may have multiple material finish options. Finish options are separated by a vertical ruled line. Lead finish/Ball material values may wrap to two lines if the finish value exceeds the maximum column width.

Important Information and Disclaimer: The information provided on this page represents TI's knowledge and belief as of the date that it is provided. TI bases its knowledge and belief on information provided by third parties, and makes no representation or warranty as to the accuracy of such information. Efforts are underway to better integrate information from third parties. TI has taken and continues to take reasonable steps to provide representative and accurate information but may not have conducted destructive testing or chemical analysis on incoming materials and chemicals. TI and TI suppliers consider certain information to be proprietary, and thus CAS numbers and other limited information may not be available for release.

In no event shall TI's liability arising out of such information exceed the total purchase price of the TI part(s) at issue in this document sold by TI to Customer on an annual basis.

TAPE AND REEL INFORMATION

QUADRANT ASSIGNMENTS FOR PIN 1 ORIENTATION IN TAPE

*All dimensions are nominal

Device	Package Type	Package Drawing	Pins	SPQ	Reel Diameter (mm)	Reel Width W1 (mm)	A0 (mm)	B0 (mm)	K0 (mm)	P1 (mm)	W (mm)	Pin1 Quadrant
BQ25306RTER	WQFN	RTE	16	3000	330.0	12.4	3.3	3.3	1.1	8.0	12.0	Q2

TAPE AND REEL BOX DIMENSIONS

*All dimensions are nominal

Device	Package Type	Package Drawing	Pins	SPQ	Length (mm)	Width (mm)	Height (mm)
BQ25306RTER	WQFN	RTE	16	3000	367.0	367.0	35.0

GENERIC PACKAGE VIEW

RTE 16

WQFN - 0.8 mm max height

3 x 3, 0.5 mm pitch

PLASTIC QUAD FLATPACK - NO LEAD

This image is a representation of the package family, actual package may vary.
Refer to the product data sheet for package details.

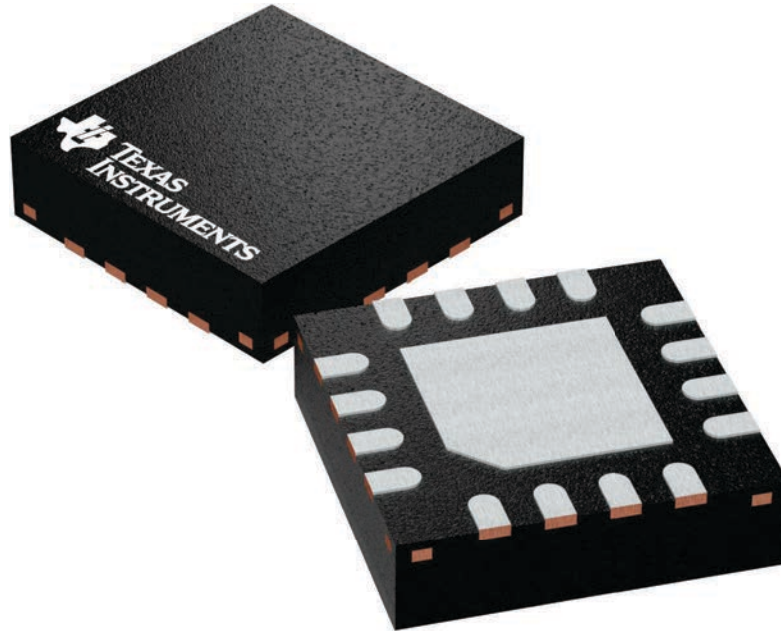

4225944/A

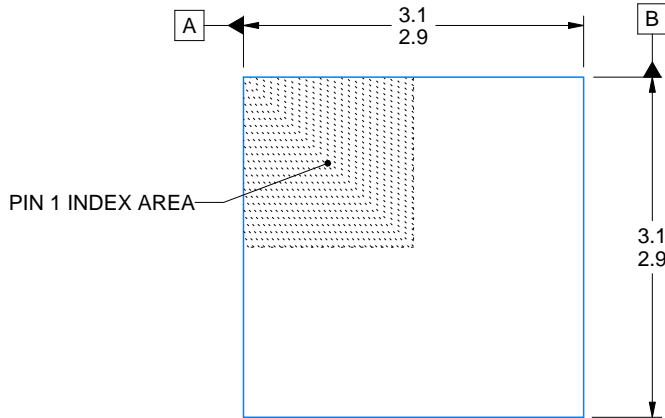

SIDE WALL METAL THICKNESS DIM A	
OPTION 1	OPTION 2
0.1	0.2

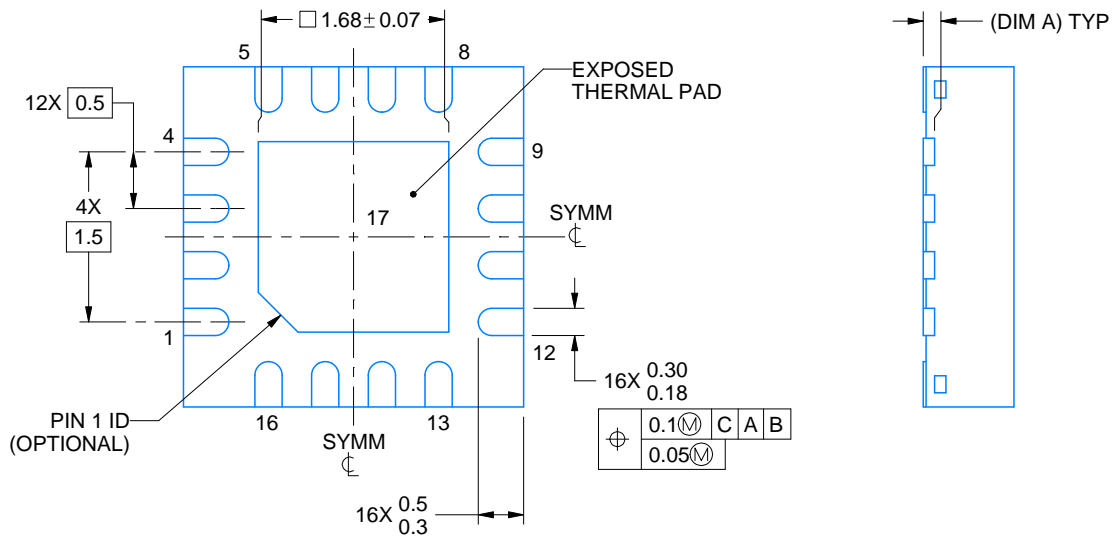
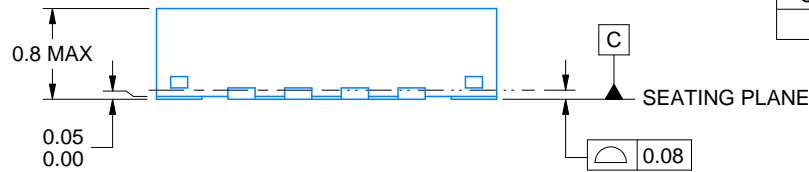

4219117/B 04/2022

NOTES:

1. All linear dimensions are in millimeters. Any dimensions in parenthesis are for reference only. Dimensioning and tolerancing per ASME Y14.5M.
2. This drawing is subject to change without notice.
3. The package thermal pad must be soldered to the printed circuit board for thermal and mechanical performance.

EXAMPLE BOARD LAYOUT

RTE0016C

WQFN - 0.8 mm max height

PLASTIC QUAD FLATPACK - NO LEAD

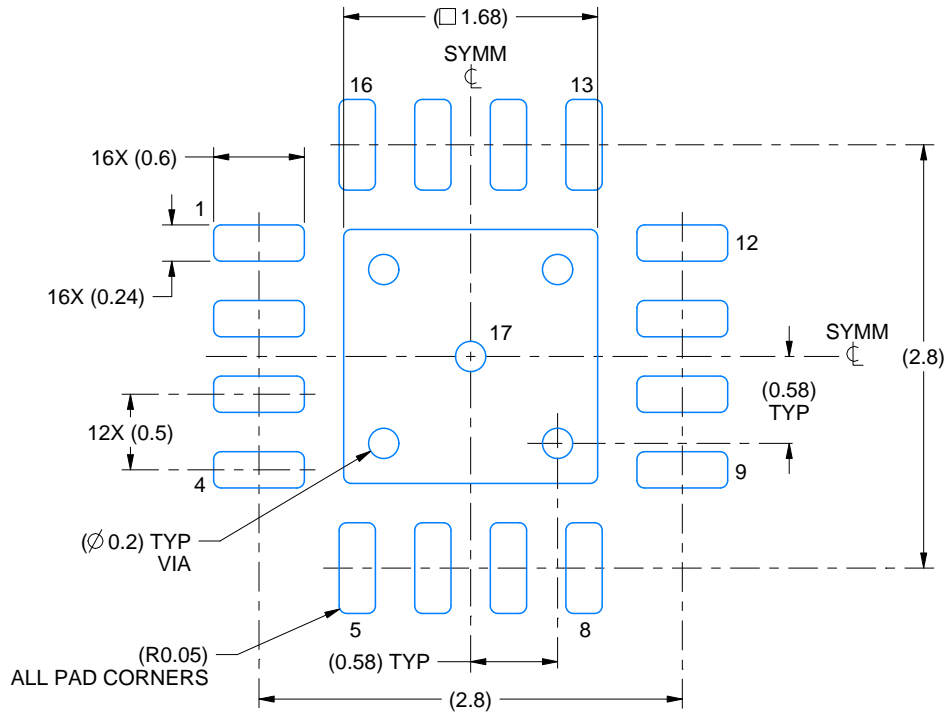

LAND PATTERN EXAMPLE
EXPOSED METAL SHOWN
SCALE:20X

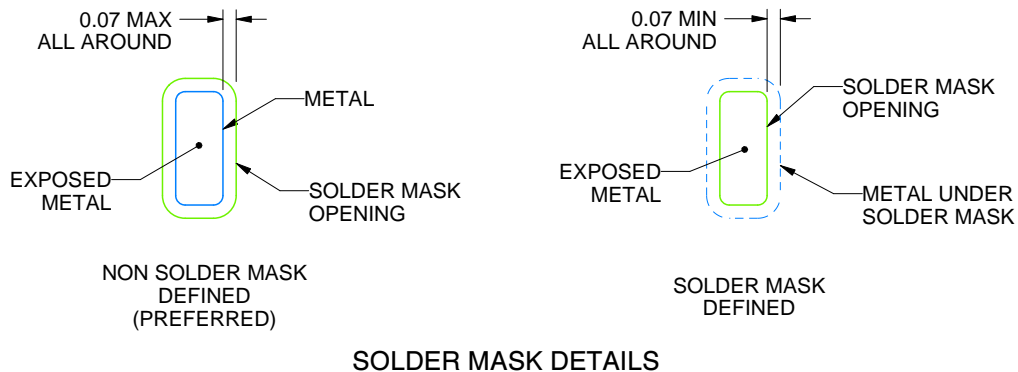

SOLDER MASK DETAILS

4219117/B 04/2022

NOTES: (continued)

- This package is designed to be soldered to a thermal pad on the board. For more information, see Texas Instruments literature number SLUA271 (www.ti.com/lit/slua271).
- Vias are optional depending on application, refer to device data sheet. If any vias are implemented, refer to their locations shown on this view. It is recommended that vias under paste be filled, plugged or tented.

EXAMPLE STENCIL DESIGN

RTE0016C

WQFN - 0.8 mm max height

PLASTIC QUAD FLATPACK - NO LEAD

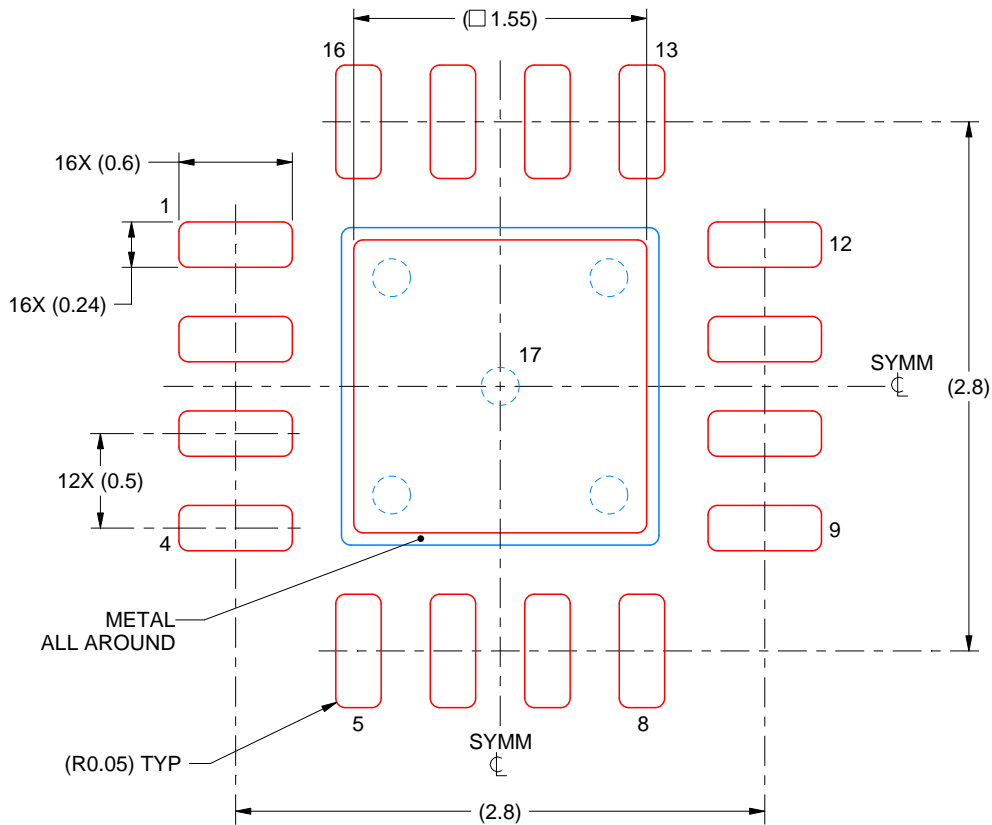

SOLDER PASTE EXAMPLE
BASED ON 0.125 mm THICK STENCIL

EXPOSED PAD 17:
85% PRINTED SOLDER COVERAGE BY AREA UNDER PACKAGE
SCALE:25X

4219117/B 04/2022

NOTES: (continued)

6. Laser cutting apertures with trapezoidal walls and rounded corners may offer better paste release. IPC-7525 may have alternate design recommendations.

IMPORTANT NOTICE AND DISCLAIMER

TI PROVIDES TECHNICAL AND RELIABILITY DATA (INCLUDING DATA SHEETS), DESIGN RESOURCES (INCLUDING REFERENCE DESIGNS), APPLICATION OR OTHER DESIGN ADVICE, WEB TOOLS, SAFETY INFORMATION, AND OTHER RESOURCES "AS IS" AND WITH ALL FAULTS, AND DISCLAIMS ALL WARRANTIES, EXPRESS AND IMPLIED, INCLUDING WITHOUT LIMITATION ANY IMPLIED WARRANTIES OF MERCHANTABILITY, FITNESS FOR A PARTICULAR PURPOSE OR NON-INFRINGEMENT OF THIRD PARTY INTELLECTUAL PROPERTY RIGHTS.

These resources are intended for skilled developers designing with TI products. You are solely responsible for (1) selecting the appropriate TI products for your application, (2) designing, validating and testing your application, and (3) ensuring your application meets applicable standards, and any other safety, security, regulatory or other requirements.

These resources are subject to change without notice. TI grants you permission to use these resources only for development of an application that uses the TI products described in the resource. Other reproduction and display of these resources is prohibited. No license is granted to any other TI intellectual property right or to any third party intellectual property right. TI disclaims responsibility for, and you will fully indemnify TI and its representatives against, any claims, damages, costs, losses, and liabilities arising out of your use of these resources.

TI's products are provided subject to [TI's Terms of Sale](#) or other applicable terms available either on [ti.com](https://www.ti.com) or provided in conjunction with such TI products. TI's provision of these resources does not expand or otherwise alter TI's applicable warranties or warranty disclaimers for TI products.

TI objects to and rejects any additional or different terms you may have proposed.

Mailing Address: Texas Instruments, Post Office Box 655303, Dallas, Texas 75265
Copyright © 2023, Texas Instruments Incorporated

Looking for pricing, stock, or lifecycle information?

Click below to explore more details on WIN SOURCE:

 [View BQ25306RTER](#) on WIN SOURCE

 [Texas Instruments](#) Information

Optimize Your Supply Chain with WIN SOURCE Solutions

-  Global Sourcing Solution
-  Obsolete Management
-  Cost Control Management
-  Shortage Management
-  Alternative Solution
-  Excess Inventory Management