



# THE DATASHEET OF BQ25302RTER



# BQ25302 Standalone 1-Cell 2.0-A Buck Battery Charger

## 1 Features

- Standalone charger and easy to configure
- High-efficiency, 1.2-MHz, synchronous switch-mode buck charger
  - 94.3% charge efficiency at 1A from 5-V input
- Single input to support USB input
  - Support 4.1-V - 6.2-V input voltage range with 28-V absolute maximum input voltage rating
  - Input Voltage Dynamic Power Management (VINDPM) tracking battery voltage
- High integration
  - Integrated reverse blocking and synchronous switching MOSFET
  - Internal input and charge current sense
  - Internal loop compensation
  - Integrated bootstrap diode
- 4.1-V / 4.2-V / 4.35-V / 4.4-V charge voltage
- 2.0-A maximum fast charge current
- 200-nA low battery leakage current at 4.5-V  $V_{BAT}$
- 4- $\mu$ A VBUS supply current in IC disable mode
- Charge current thermal regulation at 120°C
- Precharge current: 10% of fast charge current
- Termination current: 10% of fast charge current
- Charge accuracy
  - $\pm 0.5\%$  charge voltage regulation
  - $\pm 10\%$  charge current regulation
- Safety
  - Thermal regulation and thermal shutdown
  - Input Under-Voltage Lockout (UVLO) and Over-Voltage Protection (OVP)
  - Battery overcharge protection
  - Safety timer for precharge and fast charge
  - Charge disabled if current setting pin ICHG is open or short
  - Cold/hot battery temperature protection
  - Fault report on STAT pin
- Available in WQFN 3x3-16 package

## 2 Applications

- [Wireless speaker](#)
- [Barcode scanner](#)
- [Gaming](#)
- [Cradle charger](#)
- [Cordless power tool](#)
- [Building Automation](#)
- [Medical](#)

## 3 Description

The BQ25302 is a highly-integrated standalone switch-mode battery charger for single cell Li-Ion and Li-polymer batteries. The BQ25302 supports 4.1-V to 6.2-V input voltage and 2-A fast charge. The integrated current sensing topology of the device enables high charge efficiency and low BOM cost. The best-in-class 200-nA low quiescent current of the device conserves battery energy and maximizes the shelf time for portable devices. The BQ25302 is available in a 3x3 WQFN package for easy 2-layer layout and space limited applications.

### Device Information

PART NUMBER <sup>(1)</sup>	PACKAGE	BODY SIZE (NOM)
BQ25302	RTE	3.00mm x 3.00mm

- (1) For all available packages, see the orderable addendum at the end of the data sheet.

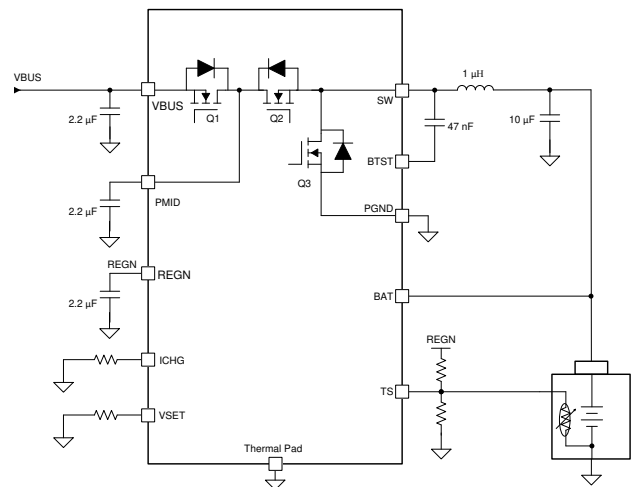

**Simplified Application**



## Table of Contents

<b>1 Features</b> .....	1	8.4 Device Functional Modes.....	18
<b>2 Applications</b> .....	1	<b>9 Application and Implementation</b> .....	20
<b>3 Description</b> .....	1	9.1 Application Information.....	20
<b>4 Revision History</b> .....	2	9.2 Typical Applications.....	20
<b>5 Description (continued)</b> .....	3	<b>10 Power Supply Recommendations</b> .....	27
<b>6 Pin Configuration and Functions</b> .....	4	<b>11 Layout</b> .....	28
<b>7 Specifications</b> .....	6	11.1 Layout Guidelines.....	28
7.1 Absolute Maximum Ratings .....	6	11.2 Layout Example.....	28
7.2 ESD Ratings .....	6	<b>12 Device and Documentation Support</b> .....	30
7.3 Recommended Operating Conditions .....	6	12.1 Device Support.....	30
7.4 Thermal Information .....	7	12.2 Documentation Support.....	30
7.5 Electrical Characteristics .....	7	12.3 Receiving Notification of Documentation Updates..	30
7.6 Timing Requirements .....	10	12.4 Support Resources.....	30
7.7 Typical Characteristics.....	11	12.5 Trademarks.....	30
<b>8 Detailed Description</b> .....	12	12.6 Electrostatic Discharge Caution.....	30
8.1 Overview.....	12	12.7 Glossary.....	30
8.2 Functional Block Diagram.....	13	<b>13 Mechanical, Packaging, and Orderable</b>	
8.3 Feature Description.....	14	<b>Information</b> .....	31

## 4 Revision History

DATE	REVISION	NOTES
October 2020	*	Initial release.

## 5 Description (continued)

The BQ25302 supports 4.1-V to 6.2-V input to charge single cell batteries. The BQ25302 provides up to 2-A continuous fast charge current to a single cell battery. The device features fast charging for portable devices. Its input voltage regulation delivers maximum charging power to the battery from input source. The solution is highly integrated with an input reverse-blocking FET (RBFET, Q1), high-side switching FET (HSFET, Q2), and low-side switching FET (LSFET, Q3).

The BQ25302 features lossless integrated current sensing to reduce power loss and BOM cost with minimized component count. It also integrates a bootstrap diode for the high-side gate drive and battery temperature monitor to simplify system design. The device initiates and completes a charging cycle without host control. The BQ25302 charge voltage and charge current are set by external resistors. The BQ25302 detects the charge voltage setting at startup and charges the battery in four phases: battery short, pre-conditioning, constant current, and constant voltage. At the end of the charging cycle, the charger automatically terminates if the charge current is below the termination current threshold and the battery voltage is above the recharge threshold. When the battery voltage falls below the recharge threshold, the charger will automatically start another charging cycle. The charger provides various safety features for battery charging and system operations, including battery temperature monitoring based on negative temperature coefficient (NTC) thermistor, charge safety timer, input over-voltage and over-current protections, as well as battery over-voltage protection. Pin open and short protection is also built in to protect against the charge current setting pin ICHG accidentally open or short to GND. The thermal regulation regulates charge current to limit die temperature during high power operation or high ambient temperature conditions.

The STAT pin output reports charging status and fault conditions. When the input voltage is removed, the device automatically enters HiZ mode with very low leakage current from battery to the charger device. The BQ25302 is available in a 3 mm x 3 mm thin WQFN package.

## 6 Pin Configuration and Functions

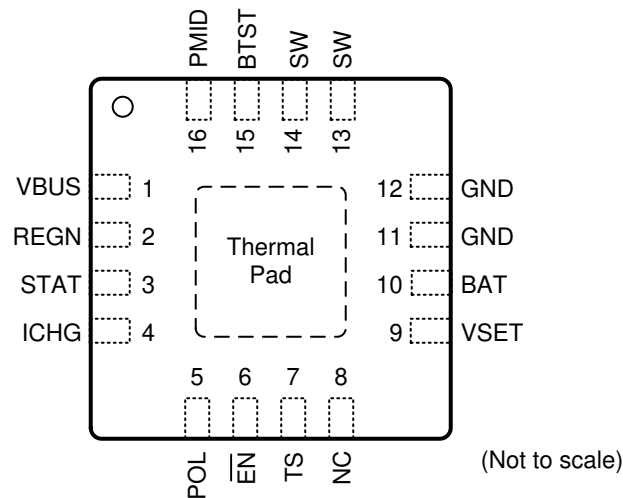

Figure 6-1. RTE Package 16-Pin WQFN Top View

Table 6-1. Pin Functions

PIN		I/O <sup>(1)</sup>	DESCRIPTION
NAME	NO.		
VBUS	1	P	Charger Input Voltage. The internal n-channel reverse block MOSFET (RBFET) is connected between VBUS and PMID with VBUS on source. Place a 2.2µF ceramic capacitor from VBUS to GND and place it as close as possible to IC.
PMID	16	P	Connected to the drain of the reverse blocking MOSFET (RBFET) and the drain of high-side MOSFET (HSFET). Place ceramic 10µF on PMID to GND and place it as close as possible to IC.
SW	13,14	P	Switching node. Connected to output inductor. Internally SW is connected to the source of the n-channel HSFET and the drain of the n-channel LSFET. Connect the 0.047µF bootstrap capacitor from SW to BTST.
BTST	15	P	High-Side FET Driver Supply. Internally, the BTST is connected to the cathode of the internal boost-strap diode. Connect the 0.047µF bootstrap capacitor from SW to BTST.
GND	11,12	P	Ground. Connected directly to thermal pad on the top layer. A single point connection is recommended between power ground and analog ground near the IC GND pins.
REGN	2	P	Low-Side FET driver positive supply output. Connect a 2.2µF ceramic capacitor from REGN to GND. The capacitor should be placed close to the IC.
BAT	10	AI	Battery Voltage Sensing Input. Connect this pin to the positive terminal of the battery pack and the node of inductor output terminal. 10-µF capacitor is recommended to connect to this pin.
TS	7	AI	Battery Temperature Protection Voltage Input. Connect a negative temperature coefficient thermistor (NTC). Program temperature window with a resistor divider from REGN to TS and TS to GND. Charge suspends when TS pin voltage is out of range. When TS pin is not used, connect a 10-kΩ resistor from REGN to TS and a 10-kΩ resistor from TS to GND. It is recommended to use a 103AT-2 thermistor.
ICHG	4	AI	Charge current program input. Connect a 1% resistor RICHG from this pin to ground to program the charge current as $ICHG = K_{ICHG} / R_{ICHG}$ ( $K_{ICHG} = 40,000$ ). No capacitor is allowed to connect at this pin. When ICHG pin is pulled to ground or left open, the charger stop switching and STAT pin starts blinking.
STAT	3	AO	Charge Status Indication Output. This pin is open drain output. Connect this pin to REGN via a current limiting resistor and LED. The STAT pin indicates charger status as: <ul style="list-style-type: none"> <li>Charge in progress: STAT pin is pulled LOW</li> <li>Charge completed, charge disabled by <math>\overline{EN}</math>: STAT pin is OPEN</li> <li>Fault conditions: STAT pin blinks.</li> </ul>
VSET	9	AI	Charge Voltage Setting Input. VSET pin sets battery charge voltage. Program battery regulation voltage with a resistor pull-down from VSET to GND: <ul style="list-style-type: none"> <li>Floating (<math>R &gt; 200k\Omega \pm 10\%</math>): 4.1V</li> <li>Shorted to GND (<math>R &lt; 510\Omega</math>): 4.2V</li> <li><math>R = 51k\Omega \pm 10\%</math>: 4.35V</li> <li><math>R = 10k\Omega \pm 10\%</math>: 4.4V</li> </ul> The maximum allowed capacitance on this pin is 50pF.
POL	5	AI	This pin must be floating.
$\overline{EN}$	6	AI	Device Disable Input. The device is enabled with $\overline{EN}$ pin floating or pulled low. The device is disabled if $\overline{EN}$ pin is pulled high.

**Table 6-1. Pin Functions (continued)**

PIN		I/O <sup>(1)</sup>	DESCRIPTION
NAME	NO.		
NC	8	-	No connection. Keep this pin floating or grounded.
Thermal Pad	17	-	Ground reference for the device that is also the thermal pad used to conduct heat from the device. This connection serves two purposes. The first purpose is to provide an electrical ground connection for the device. The second purpose is to provide a low thermal-impedance path from the device die to the PCB. This pad should be tied externally to a ground plane. Ground layer(s) are connected to thermal pad through vias under thermal pad.

(1) AI = Analog input, AO = Analog Output, AIO = Analog input Output, DI = Digital input, DO = Digital Output, DIO = Digital input Output, P = Power

## 7 Specifications

### 7.1 Absolute Maximum Ratings

Over operating free-air temperature range (unless otherwise noted)<sup>(1)</sup>

PARAMETER		MIN	MAX	UNIT
Voltage Range (with respect to GND)	VBUS (converter not switching)	-2	28	V
	PMID(converter not switching)	-0.3V	28	V
	SW	-2V <sup>(3)</sup>	20	V
	BTST	-0.3V	25.5	V
	STAT	-0.3V	5.5	V
	BAT	-0.3V	11	V
	BTST to SW	-0.3V	5.5	V
	ICHG	-0.3V	5.5	V
	REGN	-0.3V	5.5	V
	POL	-0.3V	5.5	V
	/EN	-0.3V	5.5	V
	TS	-0.3V	5.5	V
	Voltage Range (with respect to GND)	VSET	-0.3V	11 <sup>(2)</sup>
Output Sink Current	STAT		6	mA
	REGN		20	mA
Junction temperature	T <sub>J</sub>	-40C	150	°C
Storage temperature	T <sub>stg</sub>	-65C	150	°C

- (1) Stresses beyond those listed under *Absolute Maximum Rating* may cause permanent damage to the device. These are stress ratings only, which do not imply functional operation of the device at these or any other conditions beyond those indicated under *Recommended Operating Condition*. Exposure to absolute-maximum-rated conditions for extended periods may affect device reliability.
- (2) The absolute maximum rating is specified at 11V DC voltage and up to 13V for a maximum 100us
- (3) -3V for 10ns transient

### 7.2 ESD Ratings

			VALUE	UNIT
V <sub>(ESD)</sub>	Electrostatic discharge	Human body model (HBM), per ANSI/ESDA/ JEDEC JS-001, all pins <sup>(1)</sup>	±2000	V
		Charged device model (CDM), per JEDEC specification JESD22-C101, all pins <sup>(2)</sup>	±250	

- (1) JEDEC document JEP155 states that 500-V HBM allows safe manufacturing with a standard ESD control process.
- (2) JEDEC document JEP157 states that 250-V CDM allows safe manufacturing with a standard ESD control process.

### 7.3 Recommended Operating Conditions

over operating free-air temperature range (unless otherwise noted)

PARAMETER		MIN	NOM	MAX	UNIT
V <sub>VBUS</sub>	Input voltage	4.1		6.2	V
V <sub>BAT</sub>	Battery voltage			4.4	V
I <sub>VBUS</sub>	Input current			2	A
I <sub>SW</sub>	Output current (SW)			2	A
T <sub>A</sub>	Ambient temperature	-40		85	°C
L	Effective inductance	0.7	1		μH
C <sub>VBUS</sub>	Effective VBUS capacitance	1.1	2.2		μF

### 7.3 Recommended Operating Conditions (continued)

over operating free-air temperature range (unless otherwise noted)

PARAMETER		MIN	NOM	MAX	UNIT
C <sub>PMID</sub>	Effective PMID capacitance	5	10		μF
C <sub>BAT</sub>	Effective BAT capacitance	5	10		μF

### 7.4 Thermal Information

THERMAL METRIC		DEVICE	UNIT
R <sub>θJA</sub>	Junction-to-ambient thermal resistance (JEDEC <sup>(1)</sup> )	45.8	°C/W
R <sub>θJC(top)</sub>	Junction-to-case (top) thermal resistance	48.5	°C/W
R <sub>θJB</sub>	Junction-to-board thermal resistance	19.0	°C/W
Ψ <sub>JT</sub>	Junction-to-top characterization parameter	1.3	°C/W
Ψ <sub>JB</sub>	Junction-to-board characterization parameter	19.0	°C/W
R <sub>θJC(bot)</sub>	Junction-to-case (bottom) thermal resistance	7.9	°C/W

(1) For more information about traditional and new thermal metrics, see the [Semiconductor and IC Package Thermal Metrics](#) application report.

### 7.5 Electrical Characteristics

V<sub>VBUS\_UVLOZ</sub> < V<sub>VBUS</sub> < V<sub>VBUS\_OVP</sub> and V<sub>VBUS</sub> > V<sub>BAT</sub> + V<sub>SLEEP</sub>, T<sub>J</sub> = -40°C to +125°C, and T<sub>J</sub> = 25°C for typical values (unless otherwise noted)

PARAMETER		TEST CONDITIONS	MIN	TYP	MAX	UNIT
<b>QUIESCENT CURRENT</b>						
I <sub>VBUS_REVS</sub>	VBUS reverse current from BAT/SW to VBUS, T <sub>J</sub> = -40°C - 85°C	V <sub>BAT</sub> = V <sub>SW</sub> = 4.5V, V <sub>VBUS</sub> is shorted to GND, measure V <sub>VBUS</sub> reverse current		0.07	3	μA
I <sub>Q_VBUS_DIS</sub>	VBUS leakage current in disable mode, T <sub>J</sub> = -40°C - 85°C	V <sub>VBUS</sub> = 5V, V <sub>BAT</sub> = 4V, charger is disabled, /EN is pulled high			4.1	μA
I <sub>Q_BAT_DIS</sub>	Leakage current from battery in disable mode, T <sub>J</sub> = -40°C - 65°C	V <sub>VBUS</sub> = 5V, V <sub>BAT</sub> = 4V, charger is disabled, POL is grounded /EN is floating			1.0	μA
I <sub>Q_BAT_HI_Z</sub>	BAT and SW pin leakage current in HiZ mode, T <sub>J</sub> = -40°C - 65°C	V <sub>BAT</sub> = V <sub>SW</sub> = 4.5V, V <sub>VBUS</sub> floating		0.17	1.0	μA
<b>VBUS POWER UP</b>						
V <sub>VBUS_OP</sub>	VBUS operating range		4.1		6.2	V
V <sub>VBUS_UVLOZ</sub>	VBUS power on reset	V <sub>VBUS</sub> rising	3.0		3.80	V
V <sub>VBUS_UVLOZ_HYS</sub>	VBUS power on reset hysteresis	V <sub>VBUS</sub> falling		250		mV
V <sub>VBUS_LOWV</sub>	A condition to turnon REGN	V <sub>VBUS</sub> rising, REGN turns on, V <sub>BAT</sub> = 3.2V	3.8	3.90	4.00	V
V <sub>VBUS_LOWV_HYS</sub>	A condition to turnon REGN, hysteresis	V <sub>VBUS</sub> falling, REGN turns off, V <sub>BAT</sub> = 3.2V		300		mV
V <sub>SLEEP</sub>	Enter sleep mode threshold	V <sub>VBUS</sub> falling, V <sub>VBUS</sub> - V <sub>BAT</sub> , V <sub>VBUS_LOWV</sub> < V <sub>BAT</sub> < V <sub>BATREG</sub>	30	60	100	mV
V <sub>SLEEPZ</sub>	Exit sleep mode threshold	V <sub>VBUS</sub> rising, V <sub>VBUS</sub> - V <sub>BAT</sub> , V <sub>VBUS_LOWV</sub> < V <sub>BAT</sub> < V <sub>BATREG</sub>	110	157	250	mV
V <sub>VBUS_OVP_RISE</sub>	VBUS overvoltage rising threshold	V <sub>VBUS</sub> rising, converter stops switching	6.20	6.40	6.60	V
V <sub>VBUS_OVP_HYS</sub>	VBUS overvoltage falling hysteresis	V <sub>VBUS</sub> falling, converter stops switching		500		mV
<b>MOSFETS</b>						
R <sub>DS(on)_Q1</sub>	Top reverse blocking MOSFET on-resistance between VBUS and PMID (Q1)	V <sub>REGN</sub> = 5V		40	65	mΩ

## 7.5 Electrical Characteristics (continued)

$V_{VBUS\_UVLOZ} < V_{VBUS} < V_{VBUS\_OVP}$  and  $V_{VBUS} > V_{BAT} + V_{SLEEP}$ ,  $T_J = -40^{\circ}\text{C}$  to  $+125^{\circ}\text{C}$ , and  $T_J = 25^{\circ}\text{C}$  for typical values (unless otherwise noted)

PARAMETER		TEST CONDITIONS	MIN	TYP	MAX	UNIT
$R_{DSON\_Q2}$	High-side switching MOSFET on-resistance between PMID and SW (Q2)	$V_{REGN} = 5\text{V}$		50	82	m $\Omega$
$R_{DSON\_Q3}$	Low-side switching MOSFET on-resistance between SW and GND (Q3)	$V_{REGN} = 5\text{V}$		45	72	m $\Omega$
<b>BATTERY CHARGER</b>						
$V_{BATREG}$	Charge voltage regulation	VSET pin floating, $T_J = -40^{\circ}\text{C}$ to $+85^{\circ}\text{C}$	4.078	4.100	4.118	V
		VSET pin is grounded, $T_J = -40^{\circ}\text{C}$ to $+85^{\circ}\text{C}$	4.178	4.200	4.218	V
		Connect VSET pin to 51k $\Omega$ resistor, $T_J = -40^{\circ}\text{C}$ to $+85^{\circ}\text{C}$	4.328	4.350	4.371	V
		Connect VSET pin to 10k $\Omega$ resistor, $T_J = -40^{\circ}\text{C}$ to $+85^{\circ}\text{C}$	4.376	4.400	4.418	V
$I_{CHG}$	Charge current regulation	ICHG set at 1.72A with $R_{ICHG}=23.2\text{k}\Omega$ , $V_{BAT} = 3.8\text{V}$ , $V_{BUS} = 5\text{V}$	1.55	1.72	1.89	A
		ICHG set at 1.0A with $R_{ICHG}=40.2\text{k}\Omega$ , $V_{BAT} = 3.8\text{V}$ , $V_{BUS} = 5\text{V}$	0.90	1.00	1.10	A
		ICHG set at 0.5A with $R_{ICHG}=78.7\text{k}\Omega$ , $V_{BAT} = 3.8\text{V}$ , $V_{BUS} = 5\text{V}$	0.40	0.517	0.60	A
$I_{TERM}$	Termination current	ICHG = 1.72A, 10% of ICHG, $R_{ICHG}=23.2\text{k}\Omega$ , $BATREG = 4.2\text{V}$ , $V_{BUS} = 5\text{V}$	138	172	206	mA
$I_{TERM}$	Termination current	ICHG = 1.0A, 10% of ICHG, $R_{ICHG}=40.2\text{k}\Omega$ , $BATREG = 4.2\text{V}$ , $V_{BUS} = 5\text{V}$	70	100	130	mA
$I_{TERM}$	Termination current	ICHG=500mA, $I_{TERM} = 63\text{mA}$ , $R_{ICHG}=78.7\text{k}\Omega$ , $BATREG = 4.2\text{V}$ , $V_{BUS} = 5\text{V}$	33	63	93	mA
$I_{PRECHG}$	Precharge current	ICHG = 1.72A, 10% of ICHG, $R_{ICHG}=23.2\text{k}\Omega$ , $V_{BATREG} = 4.2\text{V}$ , $V_{BAT} = 2.5\text{V}$ , $V_{BUS} = 5\text{V}$	115	172	225	mA
		ICHG = 1.72A, 10% of ICHG, $R_{ICHG}=40.2\text{k}\Omega$ , $V_{BATREG} = 4.2\text{V}$ , $V_{BAT} = 2.5\text{V}$ , $V_{BUS} = 5\text{V}$	50	100	150	mA
		ICHG = 1.72A, 10% of ICHG, $R_{ICHG}=78.7\text{k}\Omega$ , $V_{BATREG} = 4.2\text{V}$ , $V_{BAT} = 2.5\text{V}$ , $V_{BUS} = 5\text{V}$	28	63	98	mA
$V_{BAT\_SHORT\_RISE}$	VBAT short rising threshold	Short to precharge	2.05	2.20	2.35	V
$V_{BAT\_SHORT\_FALL}$	VBAT short falling threshold	Precharge to battery short	1.85	2.00	2.15	V
$I_{BAT\_SHORT}$	Battery short current	$V_{BAT} < V_{BAT\_SHORT\_FALL}$ , $V_{BUS} = 5\text{V}$	24	30	36	mA
$V_{BAT\_LOWV\_RISE}$	Rising threshold	Precharge to fast charge	2.90	3.00	3.10	V
$V_{BAT\_LOWV\_FALL}$	Falling threshold	Fast charge to precharge	2.60	2.70	2.80	V
$V_{RECHG\_HYS}$	Recharge hysteresis below $V_{BATREG}$	$V_{BAT}$ falling	110	160	216	mV
<b>INPUT VOLTAGE / CURRENT REGULATION</b>						
$V_{INDPM\_MIN}$	Minimum input voltage regulation	$V_{BAT} = 3.5\text{V}$ , measured at PMID pin	4.0	4.07	4.2	V
$V_{INDPM}$	Input voltage regulation	$V_{BAT} = 4\text{V}$ , measured at PMID pin, $V_{INDPM} = 1.044 * V_{BAT} + 0.125\text{V}$	4.15	4.28	4.41	V
$I_{INDPM\_2A\_5V}$	Input current regulation	$V_{VBUS} = 5\text{V}$	2.1	2.25	2.4	A
<b>BATTERY OVER-VOLTAGE PROTECTION</b>						
$V_{BAT\_OVP\_RISE}$	Battery overvoltage rising threshold	$V_{BAT}$ rising, as percentage of $V_{BATREG}$	101.9	103.5	105	%

## 7.5 Electrical Characteristics (continued)

$V_{VBUS\_UVLO} < V_{VBUS} < V_{VBUS\_OVP}$  and  $V_{VBUS} > V_{BAT} + V_{SLEEP}$ ,  $T_J = -40^{\circ}\text{C}$  to  $+125^{\circ}\text{C}$ , and  $T_J = 25^{\circ}\text{C}$  for typical values (unless otherwise noted)

PARAMETER		TEST CONDITIONS	MIN	TYP	MAX	UNIT
$V_{BAT\_OVP\_FALL}$	Battery overvoltage falling threshold	$V_{BAT}$ falling, as percentage of $V_{BATREG}$	100.0	101.6	103.1	%
<b>CONVERTER PROTECTION</b>						
$V_{BTST\_REFRESH}$	Bootstrap refresh comparator threshold	$(V_{BTST} - V_{SW})$ when LSFET refresh pulse is requested, $V_{BUS} = 5V$	2.7	3	3.3	V
$I_{HSFET\_OCP}$	HSFET cycle by cycle over current limit threshold		5.2	6.2	6.7	A
<b>STAT INDICATION</b>						
$I_{STAT\_SINK}$	STAT pin sink current		6			mA
$F_{BLINK}$	STAT pin blink frequency			1		Hz
$F_{BLINK\_DUTY}$	STAT pin blink duty cycle			50		%
<b>THERMAL REGULATION AND THERMAL SHUTDOWN</b>						
$T_{REG}$	Junction temperature regulation accuracy		111	120	133	$^{\circ}\text{C}$
$T_{SHUT}$	Thermal shutdown rising threshold	Temperature increasing		150		$^{\circ}\text{C}$
	Thermal shutdown falling threshold	Temperature decreasing		125		$^{\circ}\text{C}$
<b>BUCK MODE OPERATION</b>						
$F_{SW}$	PWM switching frequency	SW node frequency	1.02	1.20	1.38	MHz
$D_{MAX}$	Maximum PWM Duty Cycle			97.0		%
<b>REGN LDO</b>						
$V_{REGN\_UVLO}$	REGN UVLO	$V_{VBUS}$ rising			3.85	V
$V_{REGN}$	REGN LDO output voltage	$V_{VBUS} = 5V$ , $I_{REGN} = 0$ to 16mA	4.2		5.0	V
<b>ICHG SETTING</b>						
$V_{ICHG}$	ICHG pin regulated voltage		993	998	1003	mV
$R_{ICHG\_SHORT\_FALL}$	Maximum resistance to disable charge	$V_{BUS} = 5V$			1.00	k $\Omega$
$R_{ICHG\_OPEN\_RISE}$	Minimum resistance to disable charge	$V_{BUS} = 5V$ ,	565			k $\Omega$
$R_{ICHG\_MAX}$	Maximum programmable resistance at ICHG	$V_{BUS} = 5V$			250.00	k $\Omega$
$R_{ICHG\_MIN\_SLE0}$	Minimum programmable resistance at ICHG	$V_{BUS} = 5V$	17.40			k $\Omega$
$R_{ICHG\_HIGH}$	ICHG setting resistor threshold to clamp precharge and termination current to 63mA	$R_{ICHG} > R_{ICHG\_HIGH}$	60.0	65.0	70.0	k $\Omega$
$K_{ICHG}$	Charge current ratio	ICHG set at 1.72A with $R_{ICHG} = 23.2k\Omega$ , $V_{BAT} = 3.8V$ , $V_{BUS} = 5V$ , $I_{CHG} = K_{ICHG} / R_{ICHG}$	36000	40000	44000	Ax $\Omega$
$K_{ICHG}$	Charge current ratio	ICHG set at 1.0A with $R_{ICHG} = 40.2k\Omega$ , $V_{BAT} = 3.8V$ , $V_{BUS} = 5V$ , $I_{CHG} = K_{ICHG} / R_{ICHG}$	36000	40280	44000	Ax $\Omega$
$K_{ICHG}$	Charge current ratio	ICHG set at 0.5A with $R_{ICHG} = 78.7k\Omega$ , $V_{BAT} = 3.8V$ , $V_{BUS} = 5V$ , $I_{CHG} = K_{ICHG} / R_{ICHG}$	32000	40700	48000	Ax $\Omega$
<b>COLD/HOT THERMISTOR COMPARATOR</b>						
$V_{T1}\%$	TCOLD ( $0^{\circ}\text{C}$ ) threshold, charge suspended if thermistor temperature is below $T_1$	$V_{TS}$ rising, as percentage to $V_{REGN}$	72.68	73.5	74.35	%
$V_{T1}\%$	$V_{TS}$ falling	As Percentage to $V_{REGN}$	70.68	71.5	72.33	%
$V_{T3}\%$	THOT ( $45^{\circ}\text{C}$ ) threshold, charge suspended if thermistor temperature is above $T_{HOT}$	$V_{TS}$ falling, as percentage to $V_{REGN}$	46.35	47.25	48.15	%

## 7.5 Electrical Characteristics (continued)

$V_{VBUS\_UVLOZ} < V_{VBUS} < V_{VBUS\_OVP}$  and  $V_{VBUS} > V_{BAT} + V_{SLEEP}$ ,  $T_J = -40^{\circ}\text{C}$  to  $+125^{\circ}\text{C}$ , and  $T_J = 25^{\circ}\text{C}$  for typical values (unless otherwise noted)

PARAMETER		TEST CONDITIONS	MIN	TYP	MAX	UNIT
$V_{T3\%}$	$V_{TS}$ rising	As percentage to VREGN	47.35	48.25	49.15	%
<b>LOGIC I/O PIN CHARACTERISTICS (POL, EN)</b>						
$V_{ILO}$	Input low threshold	Falling			0.40	V
$V_{IH}$	Input high threshold	Rising	1.3			V
$I_{BIAS}$	High-level leakage current at /EN pin	/EN pin is pulled up to 1.8 V		1.0		$\mu\text{A}$

## 7.6 Timing Requirements

PARAMETER		TEST CONDITIONS	MIN	NOM	MAX	UNIT
<b>VBUS/BAT POWER UP</b>						
$t_{VBUS\_OV}$	VBUS OVP reaction-time	VBUS rising above $V_{BUS\_OV}$ threshold to converter turnoff		200		ns
$t_{CHG\_ON\_EN}$	Delay from enable at /EN pin to charger power on	/EN pin voltage rising		245		ms
$t_{CHG\_ON\_VBUS}$	Delay from VBUS to charge start	/EN pin is grounded, battery present		275		ms
<b>BATTERY CHARGER</b>						
$t_{SAFETY\_FAST}$	Charge safety timer	Fast charge safety timer 20 hours	15.0	20.0	24.0	hr
$t_{SAFETY\_PRE}$	Charge safety timer	Precharge safety timer	1.5	2.0	2.5	hr

## 7.7 Typical Characteristics

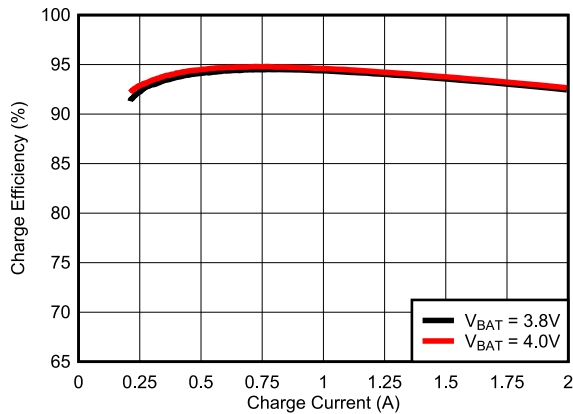

$f_{SW} = 1.2 \text{ MHz}$                       Inductance  $1 \mu\text{H}$   
 $V_{BUS} = 5 \text{ V}$                               Inductor DCR =  $14.6 \text{ m}\Omega$

**Figure 7-1. Battery Charge Efficiency vs. Charge Current**

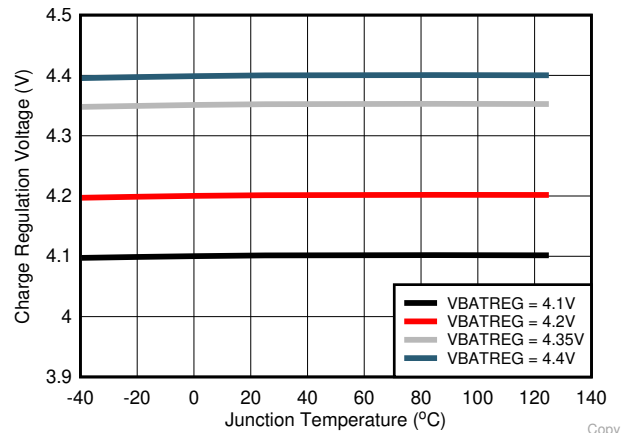

**Figure 7-2. Battery Charge Regulation Voltage vs. Junction Temperature**

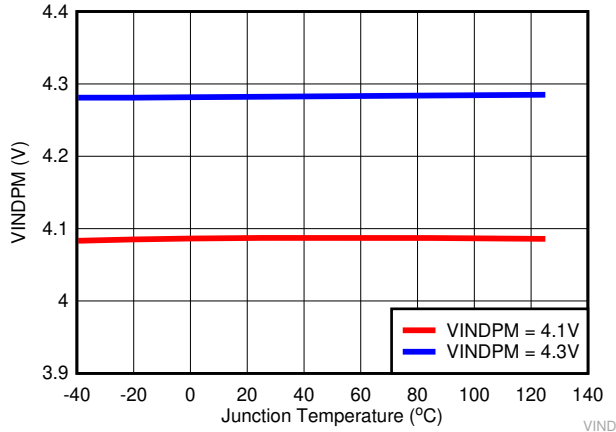

**Figure 7-3. VINDPM vs. Junction Temperature**

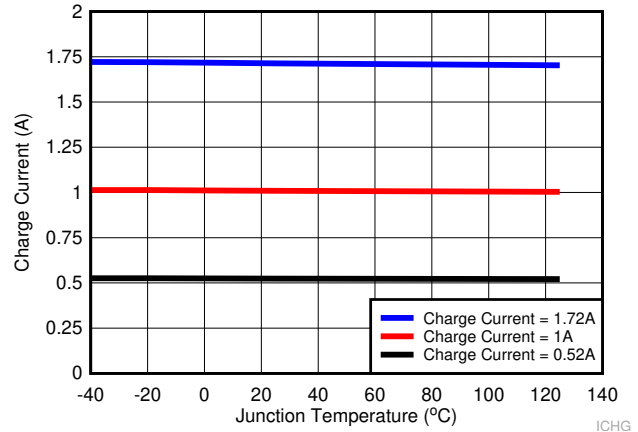

**Figure 7-4. Charge Current vs. Junction Temperature**

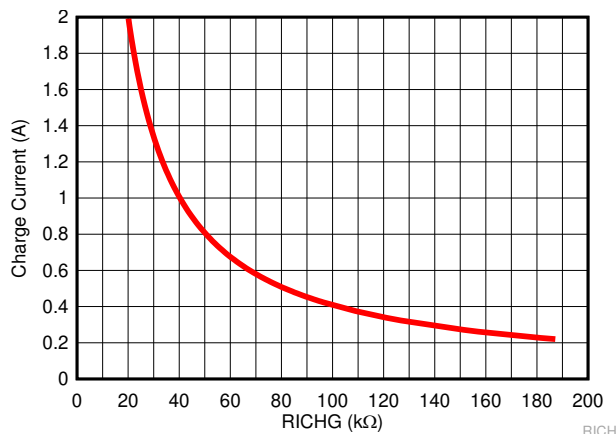

**Figure 7-5. Charge Current vs. Charge Current Setting Resistance RICHG**

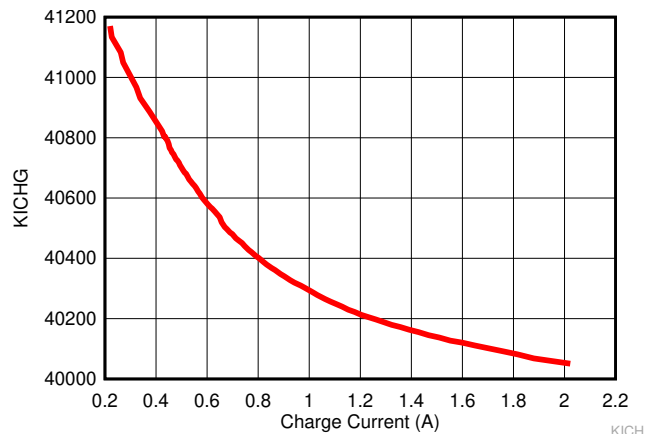

**Figure 7-6. KICHG vs. Charge Current**

## 8 Detailed Description

### 8.1 Overview

The BQ25302 is a highly integrated standalone switch-mode battery charger for single cell Li-Ion and Li-polymer batteries with charge voltage and charge current programmable by an external resistor. It includes an input reverse-blocking FET (RBFET, Q1), high-side switching FET (HSFET, Q2), low-side switching FET (LSFET, Q3), and bootstrap diode for the high-side gate drive as well as current sensing circuitry.

## 8.2 Functional Block Diagram

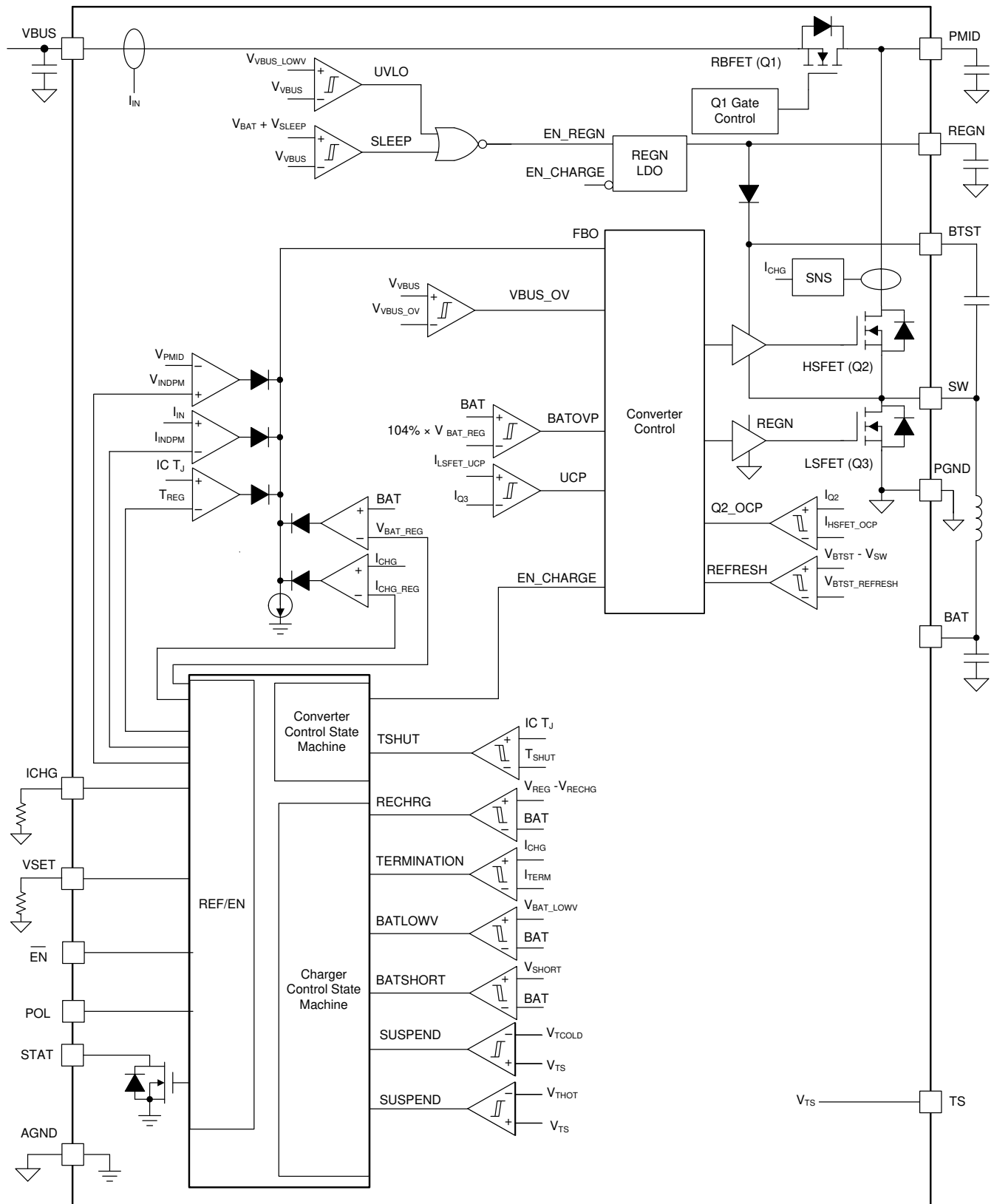

## 8.3 Feature Description

### 8.3.1 Device Power Up

The  $\overline{\text{EN}}$  pin enable or disable the device. When the device is disabled, the device draws minimum current from VBUS pin. POL grounding or floating determines the polarity of the  $\overline{\text{EN}}$  pin. The device can be powered up from either VBUS or by enabling the device from  $\overline{\text{EN}}$  pin.

#### 8.3.1.1 Power-On-Reset (POR)

The  $\overline{\text{EN}}$  pin can enable or disable the device. When the device is disabled, the device is in disable mode and it draws minimum current at VBUS. When the device is enabled, if VBUS rises above  $V_{\text{VBUS\_UVLOZ}}$ , the device powers part of internal bias and comparators and starts Power on Reset (POR).

#### 8.3.1.2 REGN Regulator Power Up

The internal bias circuits are powered from the input source. The REGN supplies internal bias circuits as well as the HSFET and LSFET gate drive. The REGN also provides voltage rail to STAT LED indication. The REGN is enabled when all the below conditions are valid:

- Chip is enabled by  $\overline{\text{EN}}$  pin
- $V_{\text{VBUS}}$  above  $V_{\text{VBUS\_UVLOZ}}$
- $V_{\text{VBUS}}$  above  $V_{\text{BAT}} + V_{\text{SLEEPZ}}$
- After sleep comparator deglitch time, VSET detection time, and REGN delay time

REGN remains on at fault conditions. REGN is powered by VBUS only and REGN is off when VBUS power is removed.

#### 8.3.1.3 Charger Power Up

Following REGN power-up, if there is no fault conditions, the charger powers up with soft start. If there is any fault, the charger will remain off until fault is clear. Any of the fault conditions below gates charger power-up:

- $V_{\text{VBUS}} > V_{\text{VBUS\_OVP}}$
- Thermistor cold/hot fault on TS pin
- $V_{\text{BAT}} > V_{\text{BAT\_OVP}}$
- Safety timer fault
- ICHG pin is open or short to GND
- Die temperature is above TSHUT

#### 8.3.1.4 Charger Enable and Disable by $\overline{\text{EN}}$ Pin

The charger can be enabled or disabled by  $\overline{\text{EN}}$  pin pulled high or low. The charger is in disable mode when disabled.

#### 8.3.1.5 Device Unplugged from Input Source

When  $V_{\text{BUS}}$  is removed from an adaptor, the device stays in HiZ mode and the leakage current from the battery to BAT pin and SW pin is less than  $I_{\text{Q\_BAT\_HIZ}}$ .

### 8.3.2 Battery Charging Management

The BQ25302 charges 1-cell Li-Ion battery with up to 2.0-A charge current from 4.1-V to 6.2-V input voltage. A new charge cycle starts when the charger power-up conditions are met. The charge voltage is set by external resistor connected at VSET pin and charge current are set by external resistors at ICHG pin. The charger terminates the charging cycle when the charging current is below termination threshold  $I_{\text{TERM}}$  and charge voltage is above recharge threshold ( $V_{\text{BATREG}} - V_{\text{RECHG\_HYS}}$ ), and device is not in IINDPM or thermal regulation. When a fully charged battery's voltage is discharged below recharge threshold, the device automatically starts a new charging cycle with safety timer reset. To initiate a recharge cycle, the conditions of charger power-up must be met. The STAT pin output indicates the charging status of charging (LOW), charging complete or charge disabled (HIGH) or charging faults (BLINKING).

### 8.3.2.1 Battery Charging Profile

The device charges the battery in four phases: battery short, preconditioning, constant current, constant voltage. The device charges battery based on charge voltage set by VSET pin and charge current set by ICHG pin as well as actual battery voltage. The battery charging profile is shown in Figure 8-1. The battery short current is provided by internal linear regulator.

Table 8-1. Charging Current Setting

MODE	BATTERY VOLTAGE $V_{BAT}$	CHARGE CURRENT	TYPICAL VALUE
Battery Short	$V_{BAT} < V_{BAT\_SHORT}$	$I_{BAT\_SHORT}$	30 mA
Precharge	$V_{BAT\_SHORT} < V_{BAT} < V_{BAT\_LOWV}$	$I_{PRECHG}$	10% of $I_{CHG}$
Fast Charge	$V_{BAT\_LOWV} < V_{BAT}$	$I_{CHG}$	Set by ICHG resistor

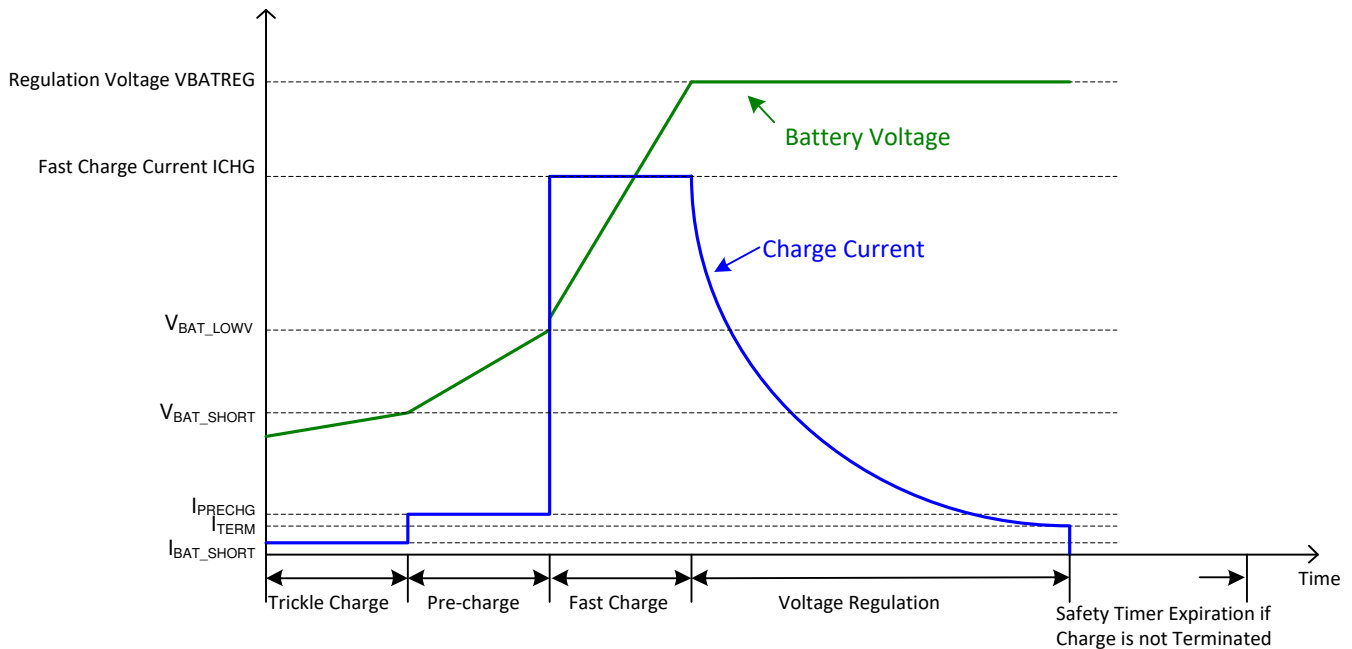

Figure 8-1. Battery Charging Profile

### 8.3.2.2 Precharge

The device charges the battery at 10% of set fast charge current in precharge mode. When  $R_{ICHG} > R_{ICHG\_HIGH}$ , the precharge current is clamped at 63mA.

### 8.3.2.3 Charging Termination

The device terminates a charge cycle when the battery voltage is above recharge threshold and the charge current is below termination current. After a charging cycle is completed, the charger is terminated and the system load is powered from battery. Termination is temporarily disabled when the charger device is in input current regulation or thermal regulation mode and the charging safety timer is counted at half the clock rate. The charge termination current is 10% of set fast charge current if  $R_{ICHG} < R_{ICHG\_HIGH}$ . The termination current is clamped at 63mA if  $R_{ICHG} > R_{ICHG\_HIGH}$ .

### 8.3.2.4 Battery Recharge

A charge cycle is completed when battery is fully charged with charge terminated. If the battery voltage decreases below the recharge threshold ( $V_{BATREG} - V_{RECHG\_HYS}$ ), the charger is enabled with safety timer reset and enabled.



$$RT2 = \frac{R_{NTC,T1} \times R_{NTC,T3} \times \left( \frac{1}{V_{T3\%}} - \frac{1}{V_{T1\%}} \right)}{R_{NTC,T1} \times \left( \frac{1}{V_{T1\%}} - 1 \right) - R_{NTC,T3} \times \left( \frac{1}{V_{T3\%}} - 1 \right)} \quad (1)$$

$$RT1 = \frac{\frac{1}{V_{T1\%}} - 1}{\frac{1}{R_{T2}} + \frac{1}{R_{NTC,T1}}} \quad (2)$$

### 8.3.3 Charging Status Indicator (STAT)

The device indicates charging state on the open drain STAT pin. The STAT pin can drive a LED that is pulled up to REGN rail through a current limit resistor.

**Table 8-2. STAT Pin State**

CHARGING STATE	STAT INDICATOR
Charging in progress (including recharge)	LOW
Charging complete	HIGH
HiZ mode, sleep mode, charge disable	HIGH
Safety timer expiration with battery voltage above recharge threshold	HIGH
Charge faults: 1. VBUS input over voltage 2. TS cold/hot faults 3. Battery over voltage 4. IC thermal shutdown 5. Safety timer expiration with battery voltage below recharge threshold 6. ICHG pin open or short	BLINKING at 1 Hz with 50% duty cycle

### 8.3.4 Protections

#### 8.3.4.1 Voltage and Current Monitoring

The device closely monitors the input voltage and input current for safe operation.

##### 8.3.4.1.1 Input Over-Voltage Protection

This device integrates the functionality of an input over-voltage protection (OVP). The input OVP threshold is  $V_{VBUS\_OVP\_RISE}$ . During an input over-voltage event, the converter stops switching and safety timer stops counting as well. The converter resumes switching and the safety timer resumes counting once the VBUS voltage drops back below  $(V_{VBUS\_OVP\_RISE} - V_{VBUS\_OVP\_HYS})$ . The REGN LDO remains on during an input over-voltage event. The STAT pin blinks during an input OVP event.

##### 8.3.4.1.2 Input Voltage Dynamic Power Management (VINDPM)

When the input current of the device exceeds the current capability of the power supply, the charger device regulates PMID voltage by reducing charge current to avoid crashing the input power supply. VINDPM dynamically tracks the battery voltage. The actual VINDPM is the higher of  $V_{INDPM\_MIN}$  and  $(1.044 \times V_{BAT} + 125mV)$ .

##### 8.3.4.1.3 Input Current Limit

The device has built-in input current limit. When the input current is over the threshold  $I_{INDPM}$ , the converter duty cycle is reduced to reduce input current.

##### 8.3.4.1.4 Cycle-by-Cycle Current Limit

High-side (HS) FET current is cycle-by-cycle limited. Once the HSFET peak current hits the limit  $I_{HSFET\_OCP}$ , the HSFET shuts down until the current is reduced below a threshold.

### 8.3.4.2 Thermal Regulation and Thermal Shutdown

The device monitors the junction temperature  $T_J$  to avoid overheating the chip and limit the device surface temperature. When the internal junction temperature exceeds thermal regulation limit  $T_{REG}$ , the device lowers down the charge current. During thermal regulation, the average charging current is usually below the programmed battery charging current. Therefore, termination is disabled and the safety timer runs at half the clock rate.

Additionally, the device has thermal shutdown built in to turn off the charger when device junction temperature exceeds  $T_{SHUT}$ . The charger is reenabled when the junction temperature is 25°C below  $T_{SHUT}$ . During thermal shutdown, the safety timer stops counting and it resumes when the temperature drops below the threshold.

### 8.3.4.3 Battery Protection

#### 8.3.4.3.1 Battery Over-Voltage Protection ( $V_{BAT\_OVP}$ )

The battery voltage is clamped at 3.5% above the battery regulation voltage. When the battery voltage is over  $V_{BAT\_OVP\_RISE}$ , the converter stops switching until the battery voltage is below the falling threshold. During a battery over-voltage event, the safety timer stops counting and STAT pin reports the fault and it resumes once the battery voltage falls below the falling threshold. A 7-mA pull-down current is on the BAT pin once  $BAT\_OVP$  is triggered.  $BAT\_OVP$  may be triggered in charging mode, termination mode, and fault mode.

#### 8.3.4.3.2 Battery Short Circuit Protection

When the battery voltage falls below the  $V_{BAT\_SHORT}$  threshold, the charge current is reduced to  $I_{BAT\_SHORT}$ .

#### 8.3.4.4 ICHG Pin Open and Short Protection

To protect against ICHG pin is short or open, the charger immediately shuts off once ICHG pin is open or short to GND and STAT pin blinks to report the fault. At powerup, if ICHG pin is detected open or short to GND, the charge will not power up until the fault is clear.

## 8.4 Device Functional Modes

### 8.4.1 Disable Mode, HiZ Mode, Sleep Mode, Charge Mode, Termination Mode, and Fault Mode

The device operates in different modes depending on VBUS voltage, battery voltage, and  $\overline{EN}$  pin, POL pin, and ICHG pin connection. The functional modes are listed in the following table.

**Table 8-3. Device Functional Modes**

MODE	CONDITIONS	REGN LDO	CHARGE ENABLED	STAT PIN
Disable Mode	Device is disable	OFF	NO	OPEN
HiZ Mode	$V_{VBUS} < V_{VBUS\_UVLOZ}$ and device is enabled	OFF	NO	OPEN
Sleep Mode	$V_{VBUS} > V_{VBUS\_UVLOZ}$ and $V_{VBUS} < V_{BAT} + V_{SLEEPZ}$ and device is enabled	OFF	NO	OPEN
Charge Mode	$V_{VBUS} > V_{VBUS\_LOWV}$ and $V_{VBUS} > V_{BAT} + V_{SLEEPZ}$ and device is enabled, no faults, charge is not terminated	ON	YES	SHORT to GND

**Table 8-3. Device Functional Modes (continued)**

MODE	CONDITIONS	REGN LDO	CHARGE ENABLED	STAT PIN
Charge Termination Mode	$V_{VBUS} > V_{VBUS\_LOWV}$ and $V_{VBUS} > V_{BAT} + V_{SLEEPZ}$ and device is enabled, no faults, charge is terminated	ON	NO	OPEN
Fault Mode	$V_{BUS\_OVP}$ , TS cold/hot, $V_{BAT\_OVP}$ , IC thermal shutdown, safety timer fault, IC <sub>CHG</sub> pin open or short	ON	NO	BLINKING

## 9 Application and Implementation

---

### Note

Information in the following applications sections is not part of the TI component specification, and TI does not warrant its accuracy or completeness. TI's customers are responsible for determining suitability of components for their purposes. Customers should validate and test their design implementation to confirm system functionality.

---

### 9.1 Application Information

A typical application consists of a single cell battery charger for Li-Ion, Li-polymer batteries used in a wide range of portable devices and accessories. It integrates an input reverse-block FET (RBFET, Q1), high-side switching FET (HSFET, Q2), and low-side switching FET (LSFET, Q3). The Buck converter output is connected to the battery directly to charge the battery and power system loads. The device also integrates a bootstrap diode for high-side gate drive.

### 9.2 Typical Applications

The typical applications in this section include a standalone charger without power path, a standalone charger with external power path, and a typical application with MCU programmed charge current.

## 9.2.1 Typical Application

The typical application in this section includes a standalone charger without power path.

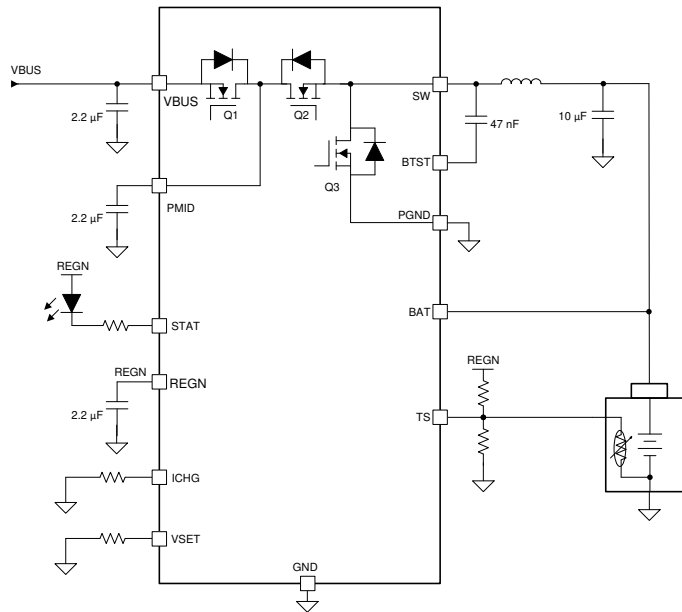

Figure 9-1. Typical Application Diagram (1-µH inductor is recommended)

### 9.2.1.1 Design Requirements

Table 9-1. Design Requirements

PARAMETER	VALUE
Input Voltage	4.1V to 6.2V
Input Current	2.0A
Fast Charge Current	2.0A
Battery Regulation Voltage	4.1V/4.2V/4.35V/4.4V

### 9.2.1.2 Detailed Design Procedure

#### 9.2.1.2.1 Charge Voltage Settings

Battery charge voltage is set by a resistor connected at the VSET pin. When the REGN LDO startup conditions are met, and before the REGN LDO powers up, the internal VSET detection circuit is enabled to detect VSET pin resistance and set battery charge voltage accordingly. The VSET detection circuit is disabled after detection is complete and changing resistance values on the fly does not change the battery charge voltage. VSET detection is reenabled once the REGN LDO is recycled.

#### 9.2.1.2.2 Charge Current Setting

The charger current is set by the resistor value at the ICHG pin according to the equation below:

$$I_{\text{CHG}} (\text{A}) = K_{\text{ICHG}} (\text{A} \cdot \Omega) / R_{\text{ICHG}} (\Omega)$$

$K_{\text{ICHG}}$  is a coefficient that is listed in Electrical Characteristics table and  $R_{\text{ICHG}}$  is the resistor value from ICHG pin to GND.  $K_{\text{ICHG}}$  is typically 40,000 (A·Ω) and it is slightly shifted up at lower charge current setting. The  $K_{\text{ICHG}}$  vs. ICHG typical characteristics curve is shown in Figure 7-6.

#### 9.2.1.2.3 Inductor Selection

The 1.2-MHz switching frequency allows the use of small inductor and capacitor values to maintain an inductor saturation current higher than the charging current ( $I_{\text{CHG}}$ ) plus half the ripple current ( $I_{\text{RIPPLE}}$ ):

$$I_{SAT} \geq I_{CHG} + (1/2) I_{RIPPLE} \quad (3)$$

The inductor ripple current depends on the input voltage ( $V_{VBUS}$ ), the duty cycle ( $D = V_{BAT}/V_{VBUS}$ ), the switching frequency ( $f_s$ ) and the inductance (L).

$$I_{RIPPLE} = \frac{V_{IN} \times D \times (1 - D)}{f_s \times L} \quad (4)$$

The maximum inductor ripple current occurs when the duty cycle (D) is 0.5 or approximately 0.5. Usually inductor ripple is designed in the range between 20% and 40% maximum charging current as a trade-off between inductor size and efficiency for a practical design.

#### 9.2.1.2.4 Input Capacitor

Design input capacitance to provide enough ripple current rating to absorb the input switching ripple current. Worst case RMS ripple current is half of the charging current when the duty cycle is 0.5. If the converter does not operate at 50% duty cycle, then the worst case capacitor RMS current  $I_{CIN}$  occurs where the duty cycle is closest to 50% and can be estimated using [Equation 5](#).

$$I_{CIN} = I_{CHG} \times \sqrt{D \times (1 - D)} \quad (5)$$

A low ESR ceramic capacitor such as X7R or X5R is preferred for the input decoupling capacitor and should be placed as close as possible to the drain of the high-side MOSFET and source of the low-side MOSFET. The voltage rating of the capacitor must be higher than the normal input voltage level. A rating of 16-V or higher capacitor is preferred for 5-V input voltage.

#### 9.2.1.2.5 Output Capacitor

Ensure that the output capacitance has enough ripple current rating to absorb the output switching ripple current. The equation below shows the output capacitor RMS current  $I_{COUT}$  calculation.

$$I_{COUT} = \frac{I_{RIPPLE}}{2 \times \sqrt{3}} \approx 0.29 \times I_{RIPPLE} \quad (6)$$

The output capacitor voltage ripple can be calculated as follows:

$$\Delta V_O = \frac{V_{OUT}}{8LCf_s^2} \left( 1 - \frac{V_{OUT}}{V_{IN}} \right) \quad (7)$$

At certain input and output voltage and switching frequency, the voltage ripple can be reduced by increasing the output filter LC.

### 9.2.1.3 Application Curves

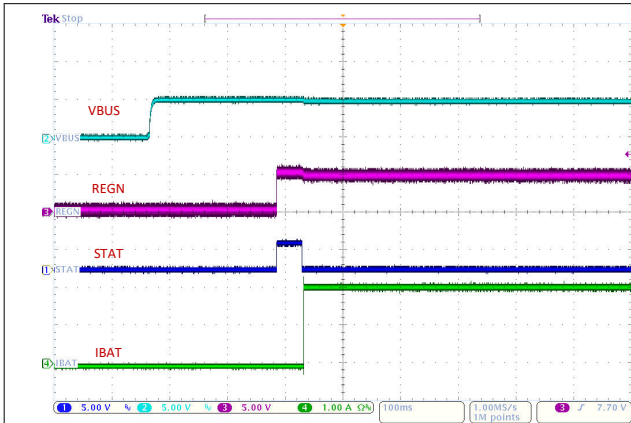

VBUS = 5 V  
 ICHG = 2A  
 Device Enabled

**Figure 9-2. Power Up from VBUS**

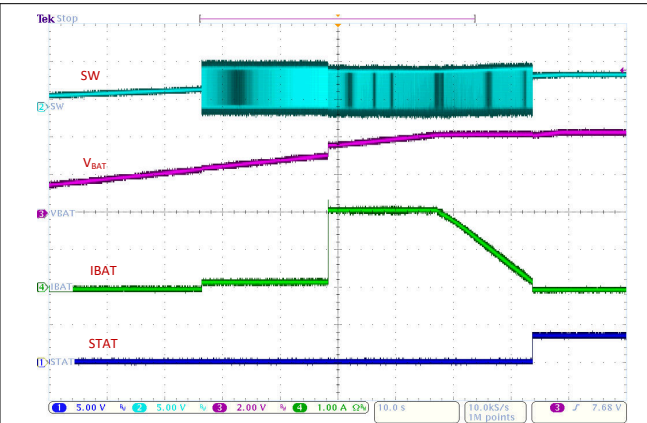

VBUS = 5 V  
 ICHG = 2 A  
 VBAT = 1.5V - 4.2V  
 VBATREG = 4.2V

**Figure 9-3. Charge Cycle with Battery Simulator**

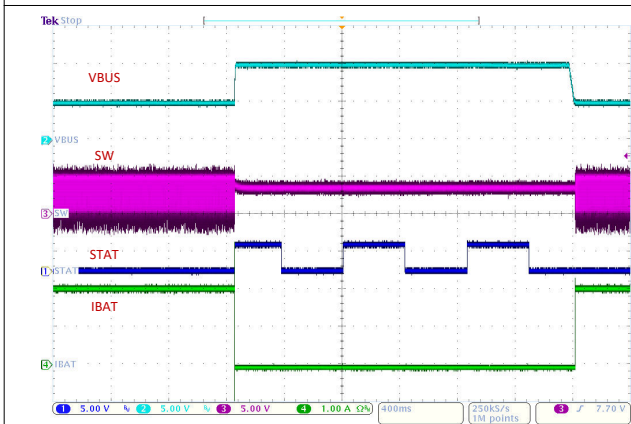

VBUS = 5 V - 10V - 5V  
 ICHG = 2A  
 Adaptor Current Limit: 1A  
 VBAT = 3.5V

**Figure 9-4. VBUS into and out of Over Voltage Protection (OVP)**

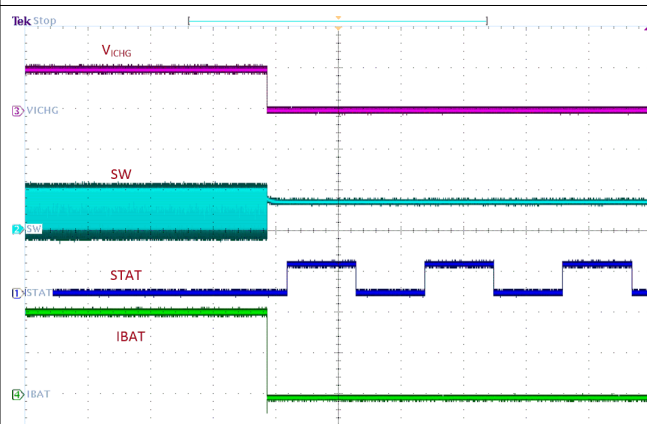

VBUS = 5 V  
 From ICHG = 2A to ICHG pin short

**Figure 9-5. ICHG Pin Short Circuit Protection**

### 9.2.2 Typical Application with External Power Path

In the case where a system needs to be immediately powered up from VBUS when the battery is overdischarged or dead, the application circuit shown in [Figure 9-6](#) can be used to provide a power path from VBUS/PMID to VSYS. PFET Q4 is an external PFET that turns on to supply VSYS from the battery when VBUS is removed; PFET Q4 turns off when VBUS is plugged in and VSYS is supplied from VBUS/PMID.

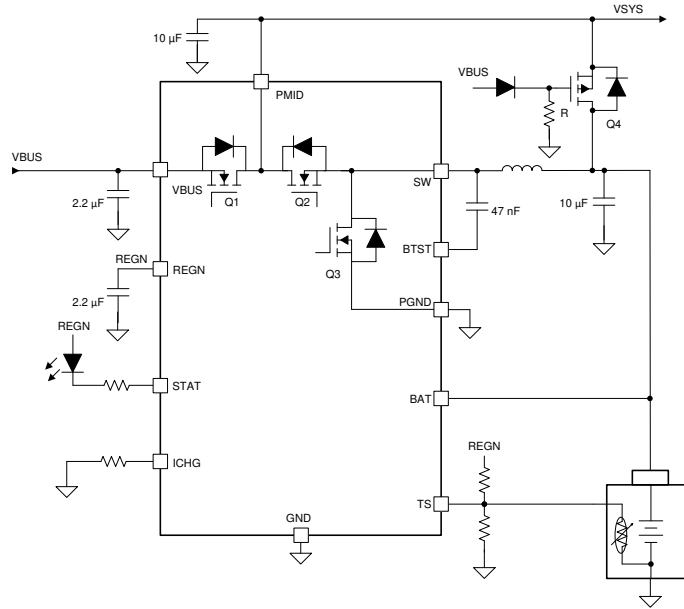

**Figure 9-6. Typical Application Diagram with Power Path**

#### 9.2.2.1 Design Requirements

For design requirements, see [Section 9.2.1.1](#).

### 9.2.3 Typical Application with MCU Programmable Charge Current

In some application cases, the charge current needs to be controlled by a MCU. In those cases, the GPIOs of the MCU can be used for on/off control of the charge current setting resistors  $R_{ICHG1}$  and  $R_{ICHG2}$  as shown in Figure 9-7. With GPIO1 and GPIO2 on/off control, three levels of charge current can be programmed. If the charge current needs to be controlled smoothly in a wide range, a PWM output of the MCU can be used to generate an average DC voltage output to program the charge current as shown in the Figure 9-7. The charge current can be calculated as:  $(1V - V_{PWM}) / (R_{ICHG1} + R_{ICHG2})$ .  $V_{PWM}$  is the averaged DC voltage of the PWM output and it must be lower than 1 V. The regulated voltage at the ICHG pin is 1 V.

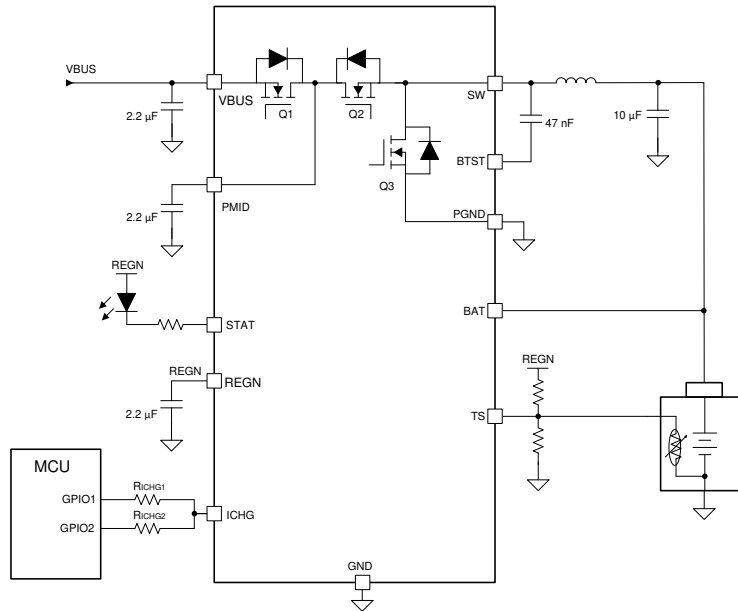

Figure 9-7. Typical Application with MCU Programmed Charge Current

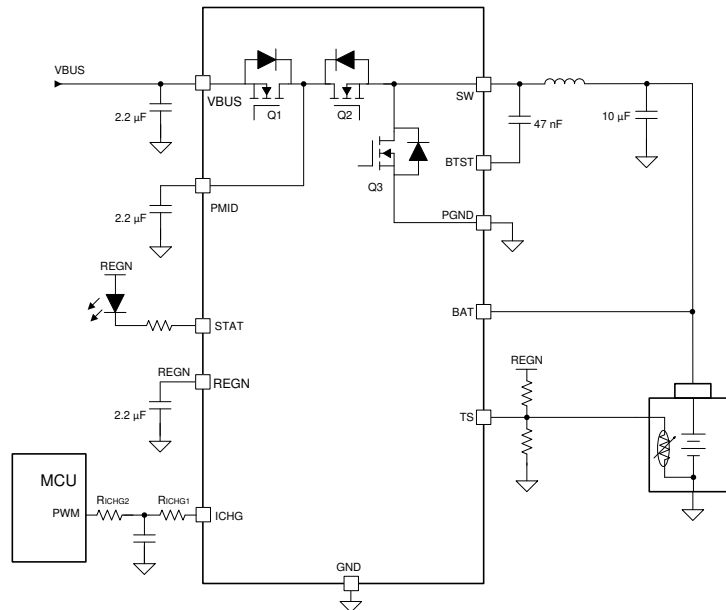

Figure 9-8. Typical Application with MCU Programmed Charge Current

### **9.2.3.1 Design Requirements**

For design requirements, see [Section 9.2.1.1](#).

## 10 Power Supply Recommendations

In order to provide an output voltage on the BAT pin, the device requires a power supply between 4.1 V and 6.2 V Li-Ion battery with positive terminal connected to BAT. The source current rating needs to be at least 2 A in order for the buck converter to provide maximum output power to BAT or the system connected to BAT pin.

## 11 Layout

### 11.1 Layout Guidelines

The switching node rise and fall times should be minimized for minimum switching loss. Proper layout of the components to minimize high frequency current path loop (see [Figure 11-1](#)) is important to prevent electrical and magnetic field radiation and high frequency resonant problems. Follow this specific order carefully to achieve the proper layout.

- Place input capacitor as close as possible to PMID pin and GND pin and use shortest copper trace connection or GND plane.
- Put output capacitor near to the inductor output terminal and the charger device. Ground connections need to be tied to the IC ground with a short copper trace or GND plane
- Place inductor input terminal to SW pin as close as possible and limit SW node copper area to lower electrical and magnetic field radiation. Do not use multiple layers in parallel for this connection. Minimize parasitic capacitance from this area to any other trace or plane.
- Route analog ground separately from power ground if possible. Connect analog ground and power ground together using thermal pad as the single ground connection point under the charger device. It is acceptable to connect all grounds to a single ground plane if multiple ground planes are not available.
- Decoupling capacitors should be placed next to the device pins and make trace connection as short as possible.
- It is critical that the exposed thermal pad on the backside of the device be soldered to the PCB ground. Ensure that there are sufficient thermal vias directly under the IC, connecting to the ground plane on the other layers
- Ensure that the number and sizes of vias allow enough copper for a given current path
- Try to avoid ground planes in parallel with high frequency traces in other layers.
- See the EVM design for the recommended component placement with trace and via locations.

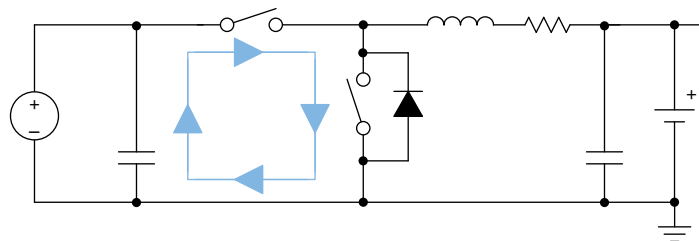

**Figure 11-1. High Frequency Current Path**

### 11.2 Layout Example

The device pinout and component count are optimized for a 2 layer PCB design. The 2-layer PCB layout example is shown in [Figure 11-2](#).

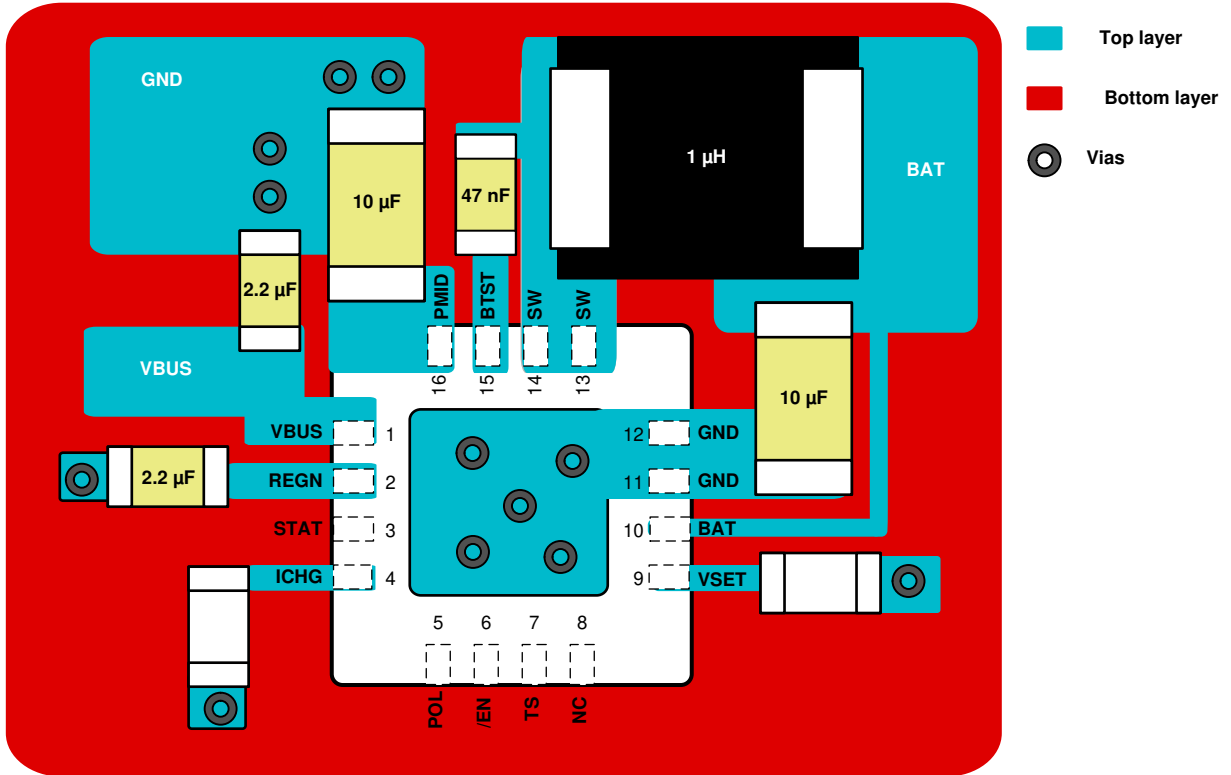

Figure 11-2. Layout Example

## 12 Device and Documentation Support

### 12.1 Device Support

#### 12.1.1 Third-Party Products Disclaimer

TI'S PUBLICATION OF INFORMATION REGARDING THIRD-PARTY PRODUCTS OR SERVICES DOES NOT CONSTITUTE AN ENDORSEMENT REGARDING THE SUITABILITY OF SUCH PRODUCTS OR SERVICES OR A WARRANTY, REPRESENTATION OR ENDORSEMENT OF SUCH PRODUCTS OR SERVICES, EITHER ALONE OR IN COMBINATION WITH ANY TI PRODUCT OR SERVICE.

### 12.2 Documentation Support

#### 12.2.1 Related Documentation

For related documentation see the following: [BQ25300](#), [BQ25301](#), [BQ25302](#), [BQ25320 Evaluation Module User's Guide](#)

### 12.3 Receiving Notification of Documentation Updates

To receive notification of documentation updates, navigate to the device product folder on [ti.com](#). Click on *Subscribe to updates* to register and receive a weekly digest of any product information that has changed. For change details, review the revision history included in any revised document.

### 12.4 Support Resources

[TI E2E™ support forums](#) are an engineer's go-to source for fast, verified answers and design help — straight from the experts. Search existing answers or ask your own question to get the quick design help you need.

Linked content is provided "AS IS" by the respective contributors. They do not constitute TI specifications and do not necessarily reflect TI's views; see TI's [Terms of Use](#).

### 12.5 Trademarks

TI E2E™ is a trademark of Texas Instruments.

All other trademarks are the property of their respective owners.

### 12.6 Electrostatic Discharge Caution



This integrated circuit can be damaged by ESD. Texas Instruments recommends that all integrated circuits be handled with appropriate precautions. Failure to observe proper handling and installation procedures can cause damage.

ESD damage can range from subtle performance degradation to complete device failure. Precision integrated circuits may be more susceptible to damage because very small parametric changes could cause the device not to meet its published specifications.

### 12.7 Glossary

[TI Glossary](#) This glossary lists and explains terms, acronyms, and definitions.

## 13 Mechanical, Packaging, and Orderable Information

The following pages include mechanical, packaging, and orderable information. This information is the most current data available for the designated devices. This data is subject to change without notice and revision of this document. For browser-based versions of this data sheet, refer to the left-hand navigation.

**PACKAGING INFORMATION**

Orderable Device	Status (1)	Package Type	Package Drawing	Pins	Package Qty	Eco Plan (2)	Lead finish/ Ball material (6)	MSL Peak Temp (3)	Op Temp (°C)	Device Marking (4/5)	Samples
BQ25302RTER	ACTIVE	WQFN	RTE	16	3000	RoHS & Green	NIPDAU	Level-1-260C-UNLIM	-40 to 85	B25302	Samples

(1) The marketing status values are defined as follows:

**ACTIVE:** Product device recommended for new designs.

**LIFEBUY:** TI has announced that the device will be discontinued, and a lifetime-buy period is in effect.

**NRND:** Not recommended for new designs. Device is in production to support existing customers, but TI does not recommend using this part in a new design.

**PREVIEW:** Device has been announced but is not in production. Samples may or may not be available.

**OBSOLETE:** TI has discontinued the production of the device.

(2) **RoHS:** TI defines "RoHS" to mean semiconductor products that are compliant with the current EU RoHS requirements for all 10 RoHS substances, including the requirement that RoHS substance do not exceed 0.1% by weight in homogeneous materials. Where designed to be soldered at high temperatures, "RoHS" products are suitable for use in specified lead-free processes. TI may reference these types of products as "Pb-Free".

**RoHS Exempt:** TI defines "RoHS Exempt" to mean products that contain lead but are compliant with EU RoHS pursuant to a specific EU RoHS exemption.

**Green:** TI defines "Green" to mean the content of Chlorine (Cl) and Bromine (Br) based flame retardants meet JS709B low halogen requirements of <=1000ppm threshold. Antimony trioxide based flame retardants must also meet the <=1000ppm threshold requirement.

(3) MSL, Peak Temp. - The Moisture Sensitivity Level rating according to the JEDEC industry standard classifications, and peak solder temperature.

(4) There may be additional marking, which relates to the logo, the lot trace code information, or the environmental category on the device.

(5) Multiple Device Markings will be inside parentheses. Only one Device Marking contained in parentheses and separated by a "~" will appear on a device. If a line is indented then it is a continuation of the previous line and the two combined represent the entire Device Marking for that device.

(6) Lead finish/Ball material - Orderable Devices may have multiple material finish options. Finish options are separated by a vertical ruled line. Lead finish/Ball material values may wrap to two lines if the finish value exceeds the maximum column width.

**Important Information and Disclaimer:**The information provided on this page represents TI's knowledge and belief as of the date that it is provided. TI bases its knowledge and belief on information provided by third parties, and makes no representation or warranty as to the accuracy of such information. Efforts are underway to better integrate information from third parties. TI has taken and continues to take reasonable steps to provide representative and accurate information but may not have conducted destructive testing or chemical analysis on incoming materials and chemicals. TI and TI suppliers consider certain information to be proprietary, and thus CAS numbers and other limited information may not be available for release.

In no event shall TI's liability arising out of such information exceed the total purchase price of the TI part(s) at issue in this document sold by TI to Customer on an annual basis.

**TAPE AND REEL INFORMATION**

**QUADRANT ASSIGNMENTS FOR PIN 1 ORIENTATION IN TAPE**

\*All dimensions are nominal

Device	Package Type	Package Drawing	Pins	SPQ	Reel Diameter (mm)	Reel Width W1 (mm)	A0 (mm)	B0 (mm)	K0 (mm)	P1 (mm)	W (mm)	Pin1 Quadrant
BQ25302RTER	WQFN	RTE	16	3000	330.0	12.4	3.3	3.3	1.1	8.0	12.0	Q2

**TAPE AND REEL BOX DIMENSIONS**

\*All dimensions are nominal

Device	Package Type	Package Drawing	Pins	SPQ	Length (mm)	Width (mm)	Height (mm)
BQ25302RTER	WQFN	RTE	16	3000	367.0	367.0	35.0

## GENERIC PACKAGE VIEW

**RTE 16**

**WQFN - 0.8 mm max height**

3 x 3, 0.5 mm pitch

PLASTIC QUAD FLATPACK - NO LEAD

This image is a representation of the package family, actual package may vary.  
Refer to the product data sheet for package details.

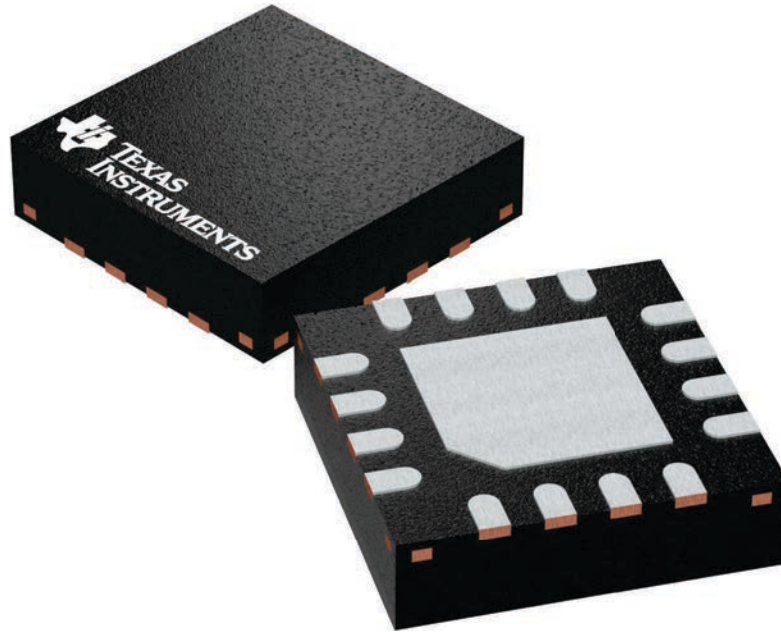

4225944/A

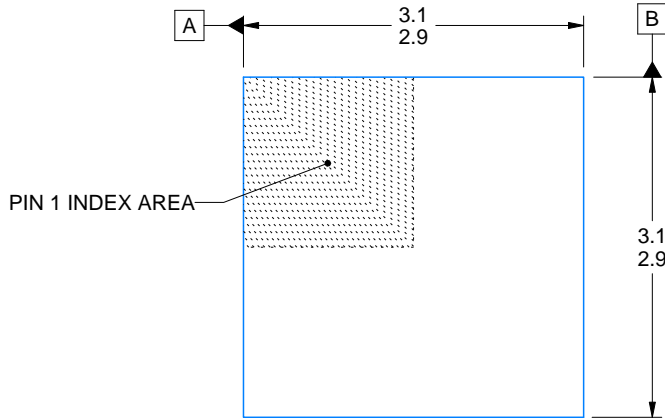

SIDE WALL METAL THICKNESS DIM A	
OPTION 1	OPTION 2
0.1	0.2

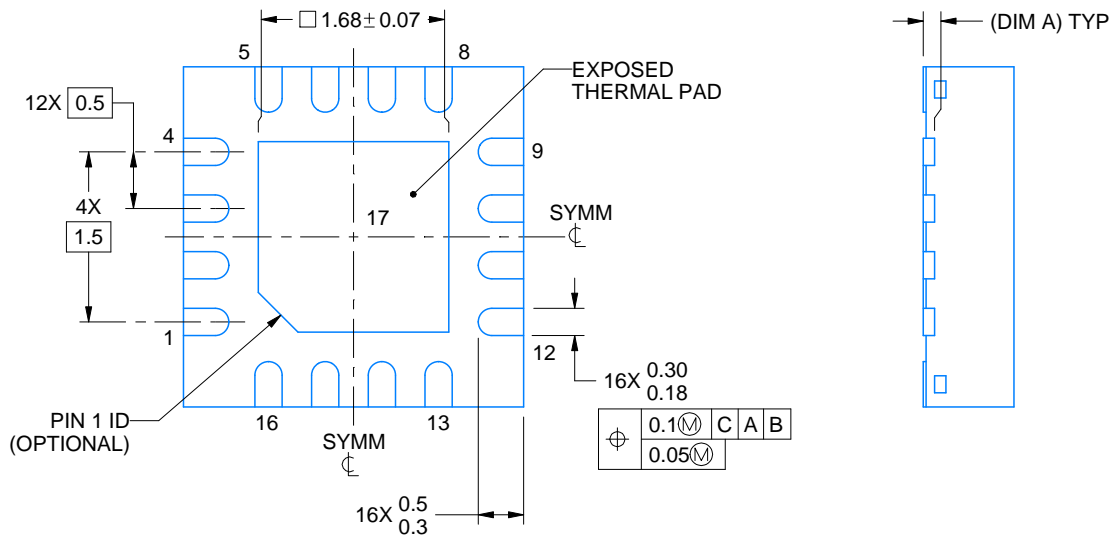
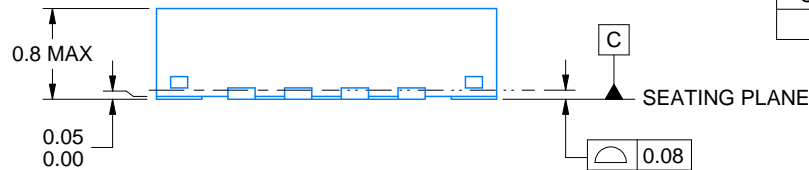

4219117/B 04/2022

NOTES:

1. All linear dimensions are in millimeters. Any dimensions in parenthesis are for reference only. Dimensioning and tolerancing per ASME Y14.5M.
2. This drawing is subject to change without notice.
3. The package thermal pad must be soldered to the printed circuit board for thermal and mechanical performance.

# EXAMPLE BOARD LAYOUT

RTE0016C

WQFN - 0.8 mm max height

PLASTIC QUAD FLATPACK - NO LEAD

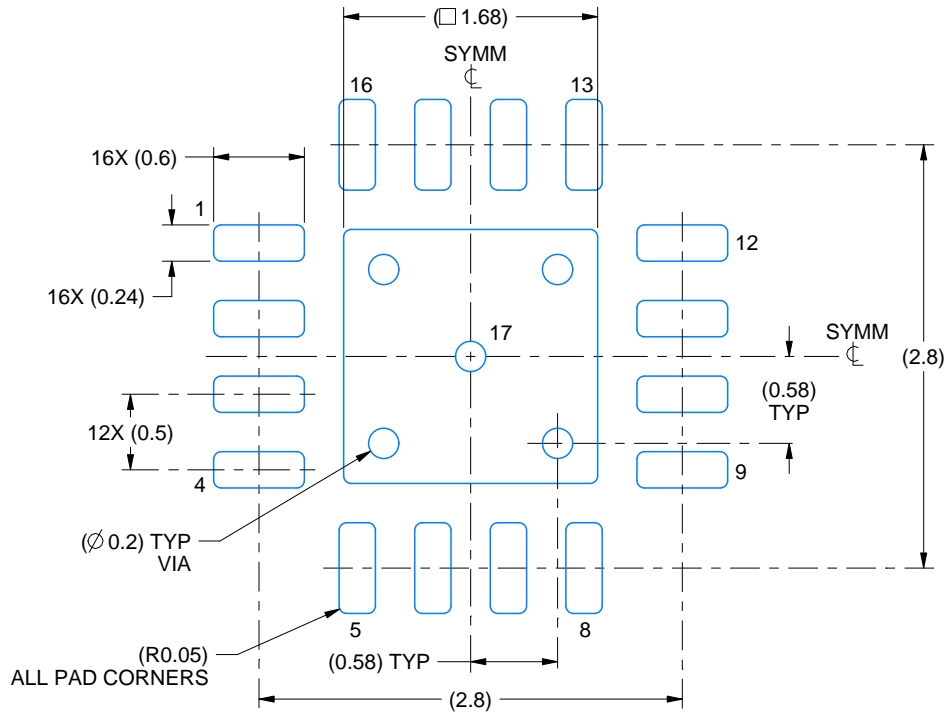

LAND PATTERN EXAMPLE  
EXPOSED METAL SHOWN  
SCALE:20X

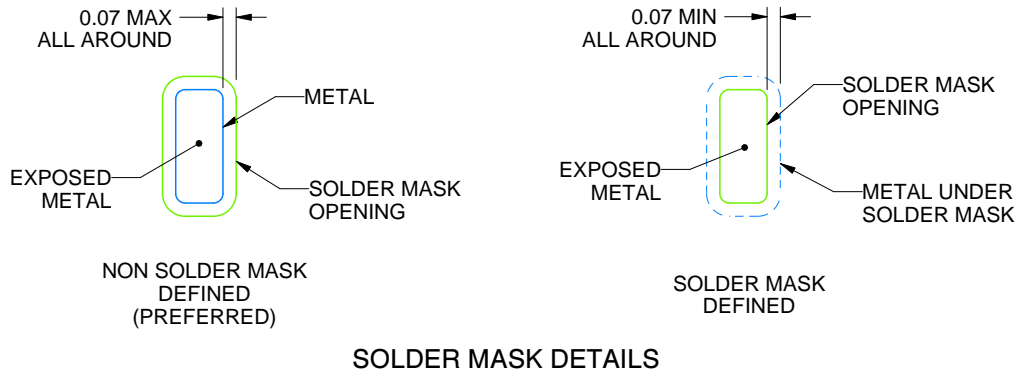

SOLDER MASK DETAILS

4219117/B 04/2022

NOTES: (continued)

- This package is designed to be soldered to a thermal pad on the board. For more information, see Texas Instruments literature number SLUA271 ([www.ti.com/lit/slua271](http://www.ti.com/lit/slua271)).
- Vias are optional depending on application, refer to device data sheet. If any vias are implemented, refer to their locations shown on this view. It is recommended that vias under paste be filled, plugged or tented.

# EXAMPLE STENCIL DESIGN

RTE0016C

WQFN - 0.8 mm max height

PLASTIC QUAD FLATPACK - NO LEAD

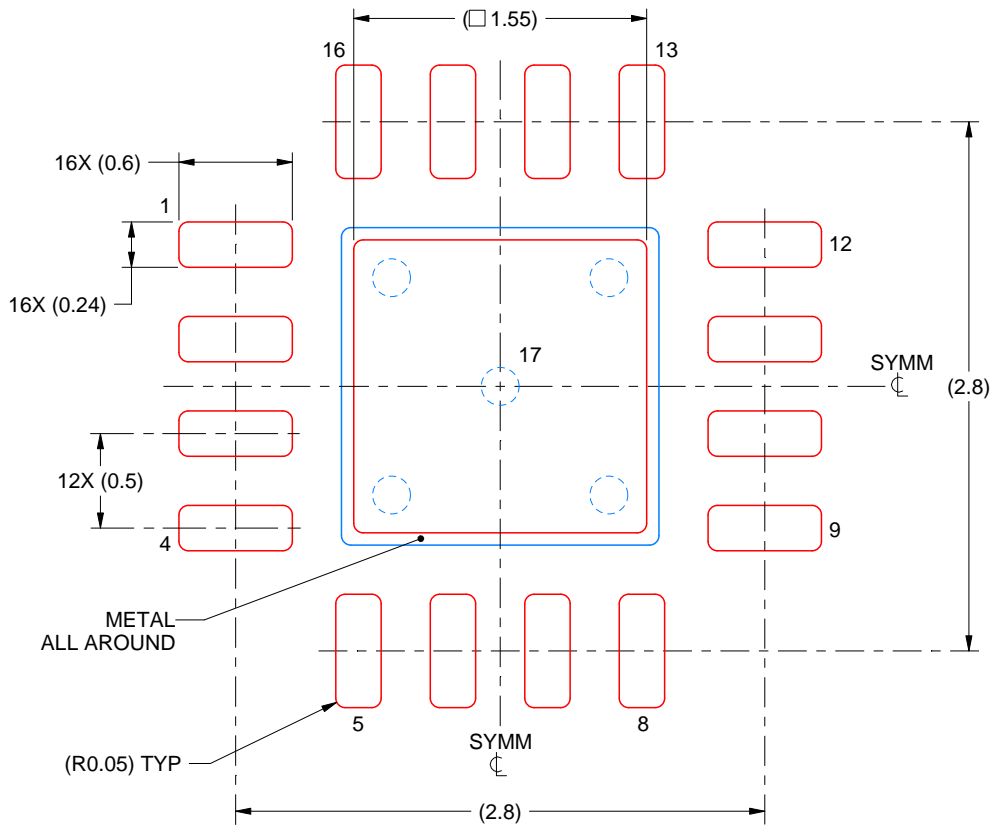

**SOLDER PASTE EXAMPLE**  
BASED ON 0.125 mm THICK STENCIL

EXPOSED PAD 17:  
85% PRINTED SOLDER COVERAGE BY AREA UNDER PACKAGE  
SCALE:25X

4219117/B 04/2022

NOTES: (continued)

6. Laser cutting apertures with trapezoidal walls and rounded corners may offer better paste release. IPC-7525 may have alternate design recommendations.

## IMPORTANT NOTICE AND DISCLAIMER

TI PROVIDES TECHNICAL AND RELIABILITY DATA (INCLUDING DATA SHEETS), DESIGN RESOURCES (INCLUDING REFERENCE DESIGNS), APPLICATION OR OTHER DESIGN ADVICE, WEB TOOLS, SAFETY INFORMATION, AND OTHER RESOURCES "AS IS" AND WITH ALL FAULTS, AND DISCLAIMS ALL WARRANTIES, EXPRESS AND IMPLIED, INCLUDING WITHOUT LIMITATION ANY IMPLIED WARRANTIES OF MERCHANTABILITY, FITNESS FOR A PARTICULAR PURPOSE OR NON-INFRINGEMENT OF THIRD PARTY INTELLECTUAL PROPERTY RIGHTS.

These resources are intended for skilled developers designing with TI products. You are solely responsible for (1) selecting the appropriate TI products for your application, (2) designing, validating and testing your application, and (3) ensuring your application meets applicable standards, and any other safety, security, regulatory or other requirements.

These resources are subject to change without notice. TI grants you permission to use these resources only for development of an application that uses the TI products described in the resource. Other reproduction and display of these resources is prohibited. No license is granted to any other TI intellectual property right or to any third party intellectual property right. TI disclaims responsibility for, and you will fully indemnify TI and its representatives against, any claims, damages, costs, losses, and liabilities arising out of your use of these resources.

TI's products are provided subject to [TI's Terms of Sale](#) or other applicable terms available either on [ti.com](https://www.ti.com) or provided in conjunction with such TI products. TI's provision of these resources does not expand or otherwise alter TI's applicable warranties or warranty disclaimers for TI products.

TI objects to and rejects any additional or different terms you may have proposed.

Mailing Address: Texas Instruments, Post Office Box 655303, Dallas, Texas 75265  
Copyright © 2023, Texas Instruments Incorporated

## Looking for pricing, stock, or lifecycle information?

Click below to explore more details on WIN SOURCE:

 [View BQ25302RTER](#) on WIN SOURCE

 [Texas Instruments](#) Information

## Optimize Your Supply Chain with WIN SOURCE Solutions

-  Global Sourcing Solution
-  Obsolete Management
-  Cost Control Management
-  Shortage Management
-  Alternative Solution
-  Excess Inventory Management