



**THE DATASHEET OF
BQ1001-9R**





MELCHER™
The Power Partners.

Q Series 66 - 132 Watt DC-DC Converters

Features

- RoHS lead-free-solder and lead-solder-exempted products are available
- 5 year warranty for RoHS compliant products with an extended temperature range
- Class I equipment
- Compliant with EN 45545 (version V106 or later)
- Wide input voltage ranges up to 154 VDC
- 1 or 2 isolated outputs from 3.3 to 24 V
- Flexible output power
- Extremely high efficiency of up to 90%
- Excellent surge and transient protection
- Outputs open and short-circuit proof
- Redundant operation, current sharing
- Extremely low inrush current, hot-swappable
- Externally adjustable output voltage and inhibit
- Electric strength test 2.1 kVDC
- Extremely slim case (4 TE, 20 mm), fully enclosed

Safety-approved to the latest edition of IEC/EN 62368-1 and UL/CSA 60950-1

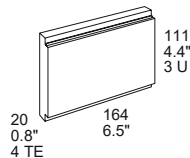

Table of Contents

Description.....	2
Model Selection.....	2
Functional Description.....	6
Electrical Input Data.....	7
Electrical Output Data.....	9
Auxiliary Functions.....	18

Electromagnetic Compatibility (EMC).....	22
Immunity to Environmental Conditions.....	24
Mechanical Data.....	26
Safety and Installation Instructions.....	27
Description of Options.....	29
Accessories.....	31

Description

These extremely compact DC-DC converters incorporate all necessary input and output filters, signaling and protection features, which are required in the majority of applications. The converters provide important advantages such as flexible output power through primary current limitation, high efficiency, excellent reliability, very low ripple and RFI noise levels, full input to output isolation, negligible inrush current, overtemperature protection, and input over-/undervoltage lockout.

The converter inputs are protected against surges and transients occurring on the source lines.

The converters are particularly suitable for rugged environment, such as railway applications. They have been designed in accordance with the European railway standards EN 50155 and EN 50121-3-2. All printed circuit boards are coated with a protective lacquer.

The outputs are continuously open- and short-circuit proof. An isolated output Power Good signal and LEDs at the front panel indicate the status of the converter. Test sockets at the front panel allow for a check of the main output voltage.

Full system flexibility and n+1 redundant operating mode are possible due to virtually unrestricted series or parallel connection capabilities of all outputs. In parallel connection of several converters, automatic current sharing is provided by a single-wire interconnection.

As a modular power supply or as part of a distributed power supply system, the extremely low-profile design reduces the necessary power supply volume without sacrificing high reliability. A temperature sensor disables the outputs when the case temperature exceeds the limit. The outputs are automatically re-enabled, when the temperature drops.

The fully enclosed, black-coated aluminum case acts as a heat sink and an RFI shield. The converters are designed for 19" DIN-rack systems occupying 3 U/4 TE only, but can also be chassis-mounted by four screws. Fitting an additional heat sink or ordering options with fitted heat sink is possible as well.

Model Selection

Table 1a: Model Selection BQ, GQ

Output 1			Output 2			Output power ¹		Operating input voltage range, efficiency						Options
$V_{o\ nom}$ [VDC]	$I_{o\ nom}$ [A]	$I_{o\ max}$ [A]	$V_{o\ nom}$ [VDC]	$I_{o\ nom}$ [A]	$I_{o\ max}$ [A]	$T_A = 71^\circ\text{C}$	$T_A = 50^\circ\text{C}$	14.4 - 36 VDC			21.6 - 54 VDC			
						$P_{o\ nom}$ [W]	$P_{o\ max}$ [W]	$V_{i\ min} - V_{i\ max}$	η_{min}^2 [%]	η_{typ} [%]	$V_{i\ min} - V_{i\ max}$	η_{min}^2 [%]	η_{typ} [%]	
3.3	20	25	-	-	-	66	82	BQ1101-9G	81		GQ1101-9G			-7, B, B1, non-G
5.1	16	20	-	-	-	82	102	BQ1001-9RG	85	86	GQ1001-9RG	85.5	86	
12 ³	8	10	-	-	-	96	120	BQ2320-9RG	87	88.5	GQ2320-9RG	87	89	-7, P, F, B, B1, non-G
15 ³	6.6	8	-	-	-	99	120	BQ2540-9RG	87	89	GQ2540-9RG	86.5	88.5	
24 ³	4.4	5.5	-	-	-	106	132	BQ2660-9RG	88	90.5	GQ2660-9RG	88	90	
5.1 ⁴	7.5	8.5	5.1 ⁴	7.5	8.5	77	97	BQ2001-9RG	85	86	GQ2001-9RG	85.5	86	-7, F, B, B1, non-G
12 ⁴	4	5	12 ⁴	4	5	96	120	BQ2320-9RG	87	88.5	GQ2320-9RG	87	89	
15 ⁴	3.3	4	15 ⁴	3.3	4	99	120	BQ2540-9RG	87	89	GQ2540-9RG	86.5	88.5	-7, P, F, B, B1, non-G
24 ⁴	2.2	2.75	24 ⁴	2.2	2.75	106	132	BQ2660-9RG	89	90.5	GQ2660-9RG	88	90	

¹ The cumulated power of both outputs cannot exceed the total power for the specified ambient temperature.

See also *Output Power at Reduced Temperature*.

² Minimum efficiency at $V_{i\ nom}$, $I_{o\ nom}$ and $T_A = 25^\circ\text{C}$

³ Double-output models with both outputs connected in parallel

⁴ Double-output models. The isolated output 2 is a tracking output 1.

NFND: Not for new designs.

Preferred for new designs

Table 1b: Model Selection CQ, 48Q

Output 1			Output 2			Output power ¹		Operating input voltage range, efficiency					Options		
$V_{o\ nom}$ [VDC]	$I_{o\ nom}$ [A]	$I_{o\ max}$ [A]	$V_{o\ nom}$ [VDC]	$I_{o\ nom}$ [A]	$I_{o\ max}$ [A]	$T_A = 71^\circ\text{C}$	$T_A = 50^\circ\text{C}$	$V_{i\ min} - V_{i\ max}$		η_{min}^2	η_{typ}	$V_{i\ min} - V_{i\ max}$		η_{min}^2	
						$P_{o\ nom}$ [W]	$P_{o\ max}$ [W]	33.6 - 75 VDC		[%]	[%]	38.4 - 75 VDC		[%]	
3.3	20	25	-	-	-	66	82	CQ1101-9G	82						-7, P, F, B, B1, non-G
5.1	16	20	-	-	-	82	102	CQ1001-9RG	85	87					-7, P, F, B, B1, non-G
5.1	16	-	-	-	-	-	82					48Q1001-2R	83		-
12 ³	8	10	-	-	-	96	120	CQ2320-9RG	88	89.5					-7, P, F, B, B1, non-G
12 ³	8	-	-	-	-	-	96					48Q2320-2R	85		-
15 ³	6.6	8	-	-	-	99	120	CQ2540-9RG	88.5	90					-7, P, F, B, B1, non-G
15 ³	6.6	-	-	-	-	-	99					48Q2540-2R	85		-
24 ³	4.4	5.5	-	-	-	106	132	CQ2660-9RG	88.5	90.5					-7, P, F, B, B1, non-G
24 ³	4.4	-	-	-	-	-	106					48Q2660-2R	87		-
5.1 ⁴	7.5	8.5	5.1 ⁴	7.5	8.5	77	97	CQ2001-9RG	85	87					-7, P, F, B, B1, non-G
12 ⁴	4	5	12 ⁴	4	5	96	120	CQ2320-9RG	87	88					-7, P, F, B, B1, non-G
12 ⁴	4	-	12 ⁴	4	-	-	96					48Q2320-2R	85		-
15 ⁴	3.3	4	15 ⁴	3.3	4	99	120	CQ2540-9RG	88.5	90					-7, P, F, B, B1, non-G
15 ⁴	3.3	-	15 ⁴	3.3	-	-	99					48Q2540-2R	85		-
24 ⁴	2.2	2.7	24 ⁴	2.2	2.7	106	132	CQ2660-9RG	88.5	90					-7, P, F, B, B1, non-G
24 ⁴	2.2	-	24 ⁴	2.2	-	-	106					48Q2660-2R	87		-

Table 1c: Model Selection DQ, EQ

Output 1			Output 2			Output power ¹		Operating input voltage range, efficiency					Options			
$V_{o\ nom}$ [VDC]	$I_{o\ nom}$ [A]	$I_{o\ max}$ [A]	$V_{o\ nom}$ [VDC]	$I_{o\ nom}$ [A]	$I_{o\ max}$ [A]	$T_A = 71^\circ\text{C}$	$T_A = 50^\circ\text{C}$	$V_{i\ min} - V_{i\ max}$		η_{min}^2	η_{typ}	$V_{i\ min} - V_{i\ max}$		η_{min}^2	η_{typ}	
						$P_{o\ nom}$ [W]	$P_{o\ max}$ [W]	43 - 108 VDC		[%]	[%]	66 - 150 VDC		[%]	[%]	
3.3	20	25	-	-	-	66	82	DQ1101-9G	82*			EQ1101-9G				-7, B, B1, non-G
5.1	16	20	-	-	-	82	102	DQ1001-9RG	85.5	86.5		EQ1001-9RG	85	86		
12 ³	8	10	-	-	-	96	120	DQ2320-9RG	88	90		EQ2320-9RG	87	89		-7, P, F, B, B1, non-G
15 ³	6.6	8	-	-	-	99	120	DQ2540-9RG	89	90.5		EQ2540-9RG	87.5	89		
24 ³	4.4	5.5	-	-	-	106	132	DQ2660-9RG	89	90		EQ2660-9RG	87.5	89		
5.1 ⁴	7.5	8.5	5.1 ⁴	7.5	8.5	77	97	DQ2001-9RG	85	86.5		EQ2001-9RG	84	86		-7, B, B1, non-G
12 ⁴	4	5	12 ⁴	4	5	96	120	DQ2320-9RG	88	90		EQ2320-9RG	87	89		
15 ⁴	3.3	4	15 ⁴	3.3	4	99	120	DQ2540-9RG	89	90.5		EQ2540-9RG	87.5	89		-7, P, F, B, B1, non-G
24 ⁴	2.2	2.75	24 ⁴	2.2	2.75	106	132	DQ2660-9RG	89	90		EQ2660-9RG	87.5	89		

¹ The cumulated power of both outputs cannot exceed the total power for the specified ambient temperature.

See also *Output Power at Reduced Temperature*.

² Minimum efficiency at $V_{i\ nom}$, $I_{o\ nom}$ and $T_A = 25^\circ\text{C}$

³ Double-output models with both outputs connected in parallel

⁴ Double-output models. The isolated output 2 is a tracking output 1.

 NFND: Not for new designs.

 Preferred for new designs

Part Number Description

		C	Q	2	5	40	-9	R	B1	G
Input voltage $V_{i\text{ nom}}$:										
24 V	B									
36 V	G									
48 V	C									
48 V (Telecom, NFND).....	48									
72 V	D									
110 V.....	E									
Series	Q									
Number of outputs:										
Single output models	1									
Double output models	2									
Single output models (long case) ²	6									
Double output models (long case) ²	7									
Nominal voltage of main output:										
3.3 V	1									
5.1 V	0									
12 V	3									
15 V	5									
24 V	6, 7									
Other voltages	7, 8, 9									
Other specifications and additional features for single output models ³	01 - 99									
Nominal voltage of output 2, $V_{o2\text{ nom}}$:										
5.1 V	01 - 09									
12 V	20 - 39									
15 V	40 - 59									
24 V	60 - 79									
Other voltages and additional features ⁵	01 - 99									
Operational ambient temperature range T_A :										
-10 to 50 °C (NFND)	-2									
-25 to 71 °C (option, NFND)	-7									
-40 to 71 °C	-9									
other ³	-0, -5, -6									
Output voltage adjust (auxiliary function)	R									
Options: Potentiometer (option, NFND) ¹	P									
No fuse (option)	F									
Additional heatsink	B, B1									
RoHS-compliant for all 6 substances	G									

¹ Option P excludes feature R and vice versa.

² Models with 220 mm case length. Just add 5000 to the standard model number, e.g., CQ2540-9RG → CQ7540-9RG.

³ Customer-specific models.

Note: The sequence of options must follow the order above. This part number description is not intended for creating part numbers.

NFND: Not for new designs. G: Preferred for new designs

Example: CQ2540-9RB1G: DC-DC converter, input voltage range 33.6 to 75V, double-output model, each output providing 15 V/3.3 A, equipped with a heat sink, operating ambient temperature $T_A = -40$ to 71 °C, RoHS-compliant for all six substances.

Note: All models have the following auxiliary functions, which are not shown in the type designation: input and output filter, inhibit, sense lines, current sharing, Out OK signal, LED indicators, and test sockets (not 48Q models).

Note: 48Q models are designed according to Telecom standards ETS 300132-2 and EN 41003. $V_{i\text{ min}}$ is 38.4 V, such limiting the input current I_i to 150% of $I_{i\text{ nom}}$.

Product Marking

Type designation, applicable safety approval and recognition marks, CE mark, warnings, pin allocation, patents, and company logo. Identification of LEDs, test sockets and potentiometer.

Input voltage range and input current, nominal output voltages and currents, degree of protection, batch no., serial no., and data code including production site, version (modification status) and date of production.

Output Configuration

The Q Series design allows different output configurations to cover almost every individual requirement, by simply wiring the outputs in parallel, series, or symmetrical configuration as per the following figures. For further information and for parallel and series operation of several converters see *Electrical Output Data*.

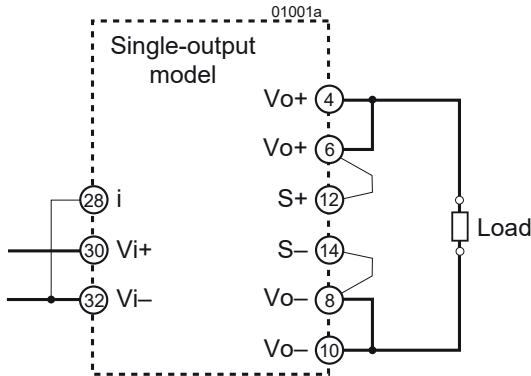

Fig. 1
Single-output configuration

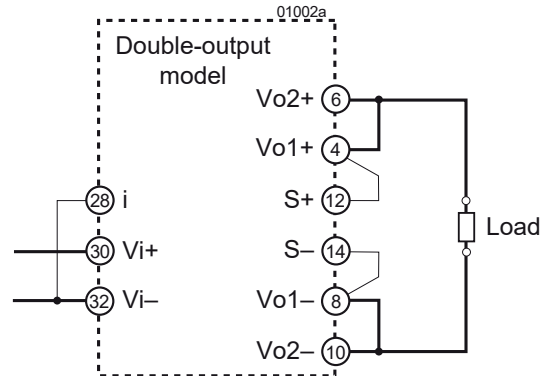

Fig. 2
Parallel-output configuration

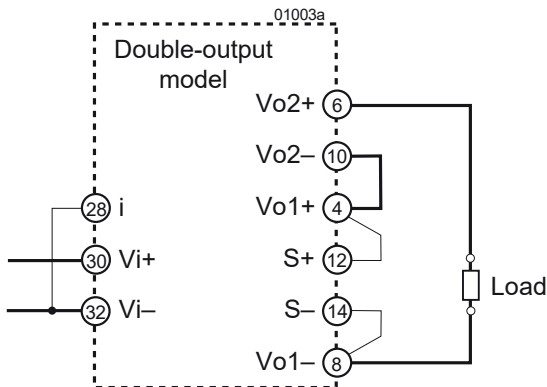

Fig. 3
Series-output configuration

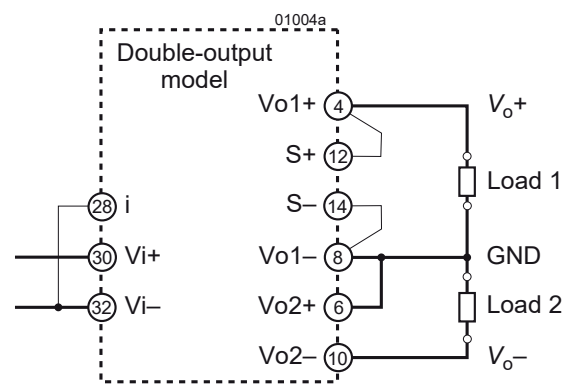

Fig. 4
Symmetrical-output configuration (with common ground)

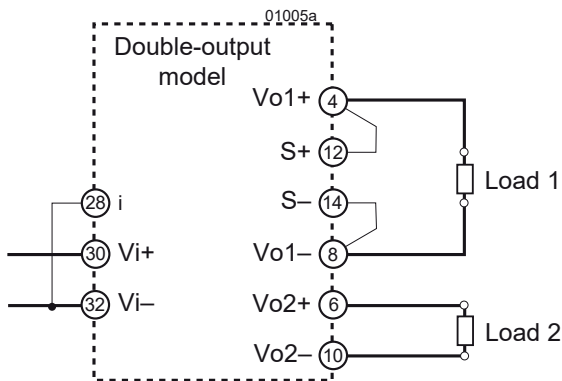

Fig. 5
Independent-output configuration

Functional Description

The converters are designed as forward converters using primary and secondary control circuits in SMD technology. The switching frequency is approximately 200 kHz under nominal operating conditions. The built-in high-efficient input filter together with a small input capacitance generate very low inrush currents of short duration. After transformer isolation and rectification, the output filter reduces ripple and noise to a minimum without compromising the dynamic ability. The output voltage is fed to the secondary control circuit via separate sense lines. The resultant error signal is sent to the primary control circuit via a signal transformer.

Double-output models have the voltage regulation of output 2 relying on the close magnetic coupling of the transformer and the output inductor together with the circuits' symmetry.

The current limitation is located at the primary side, thus limiting the total output current in overload conditions. This allows flexible loading of each output for unsymmetrical loads in the range 10 to 90% of the total output power. In applications with large dynamic load changes, we recommend connecting such a load to output 1. If output 2 is not used, it should be connected parallel to output 1. Both outputs can either be series- or parallel-connected (see *Electrical Output Data*).

In normal operation, the internal control circuits are powered by a third winding of the main choke (except 48Q models). Start-up is ensured from the input voltage by a linear regulator.

Note: When the output voltage is much lower than the nominal value, this linear regulator is activated, generating considerable power losses.

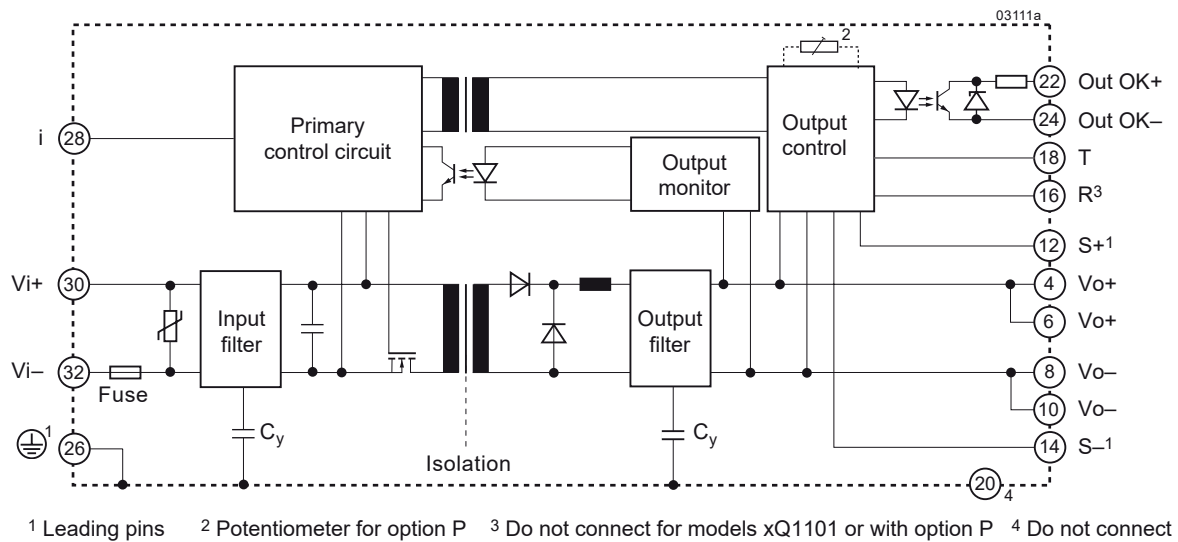

Fig. 6
Block diagram of a single-output converter

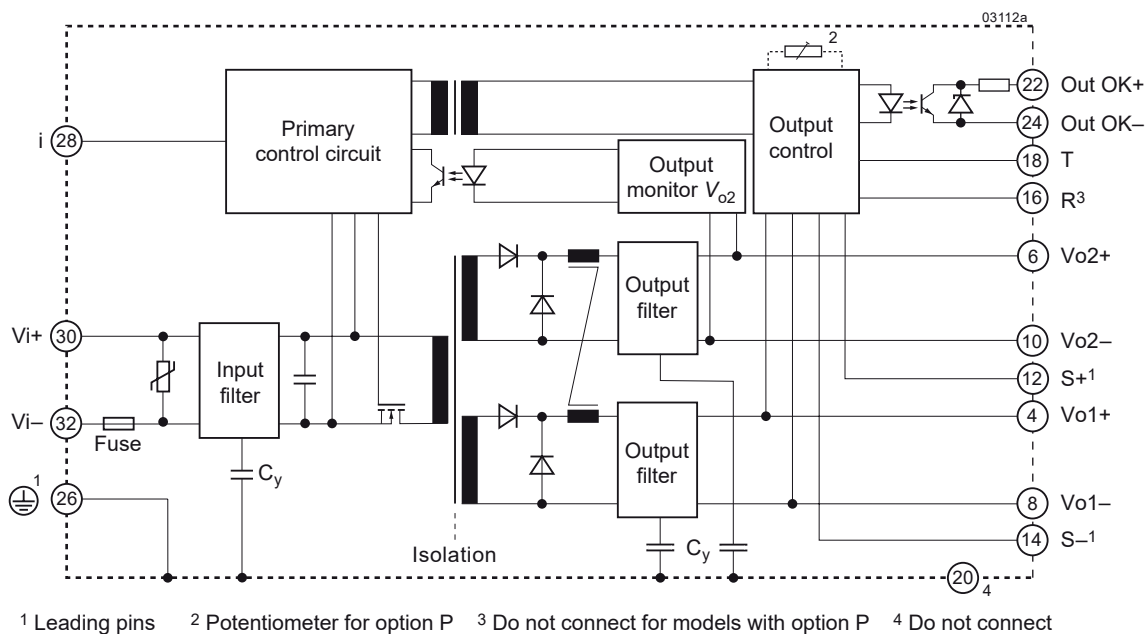

Fig. 7
Block diagram of a double-output converter

Electrical Input Data

General conditions:

- $T_A = 25\text{ °C}$, unless T_C is specified.
- Sense lines connected directly at the connector, inhibit (28) connected to Vi- (32).
- R-input not connected; with option P, V_o set to $V_{o\text{ nom}}$ at $V_{i\text{ nom}}$.

Table 2a: Input data

Model		BQ			GQ			CQ			Unit			
Characteristics	Conditions	min	typ	max	min	typ	max	min	typ	max				
V_i	Operating input voltage cont.	$I_o = 0 - I_{o\text{ max}}, T_{C\text{ min}} - T_{C\text{ max}}$			14.4		36	21.6		54	33.6		75	V
$V_{i\text{ nom}}$	Nominal input voltage				24			36			48			
$V_{i\text{ abs}}$	Input voltage limits	3 s, without damage			0		50	0		63	0		100	
I_i	Typical input current ¹	$V_{i\text{ nom}}, I_{o\text{ nom}}$			4.5			3.0			2.2			A
P_{i0}	No-load input power	$V_{i\text{ min}} - V_{i\text{ max}}, I_o = 0$			2.5			3.0			2.5			W
$P_{i\text{ inh}}$	Idle input power ⁴				1.0			1.5			1.5			
$I_{i\text{ rp}}$	Peak inrush current ²				55			40			35			A
$t_{i\text{ rr}}$	Rise time inrush	$V_{i\text{ nom}}, I_{o\text{ nom}}$			50			40			35			µs
$t_{i\text{ rh}}$	Time to half value				130			110			80			
t_{on}	Start-up time ³	$0 \rightarrow V_{i\text{ min}}, I_{o\text{ nom}}$			5			5			8			ms

Table 2b: Input data

Model		48Q ²			DQ			EQ			Unit			
Characteristics	Conditions	min	typ	max	min	typ	max	min	typ	max				
V_i	Operating input voltage cont.	$I_o = 0 - I_{o\text{ max}}$			38.4		75	43		108	66		150	V
V_{i2s}	for ≤ 2 s, without lockout	$T_{C\text{ min}} - T_{C\text{ max}}$									154			
$V_{i\text{ nom}}$	Nominal input voltage				48 ²			72			110			
$V_{i\text{ abs}}$	Input voltage limits	3 s, without damage			0		100	0		125	0		200	
I_i	Typical input current ¹	$V_{i\text{ nom}}, I_{o\text{ nom}}$			2.2			1.5			1.0			A
P_{i0}	No-load input power	$V_{i\text{ min}} - V_{i\text{ max}}, I_o = 0$			2.5			5.5			5.0			W
$P_{i\text{ inh}}$	Idle input power ⁴				1.5			3.5			3.5			
$I_{i\text{ rp}}$	Peak inrush current ²				35			20			45			A
$t_{i\text{ rr}}$	Rise time inrush	$V_{i\text{ nom}}, I_{o\text{ nom}}$			35			50			15			µs
$t_{i\text{ rh}}$	Time to half value				80			90			25			
t_{on}	Start-up time ³	$0 \rightarrow V_{i\text{ min}}, I_{o\text{ nom}}$			8			20			20			ms

- Typical input current depends on model type
- According to ETS 300132-2
- See fig. 19
- Converter inhibited

Input Fuse

An incorporated fuse in series to the negative input line protects against severe defects. The fuse is not externally accessible. Reverse polarity at the input will cause the fuse to blow.

Note: For models with no internal fuse, see opt. F. The customer must provide an appropriate external fuse or circuit breaker.

Model	Fuse type	Reference and rating
BQ	very fast acting	2x Littelfuse 251, 10 A, 125 V
GQ	very fast acting	2x Littelfuse 251, 7 A, 125 V
CQ	very fast acting	Littelfuse 251, 10 A, 125 V
48Q	very fast acting	Littelfuse 251, 10 A, 125 V
DQ	very fast acting	Littelfuse 251, 7 A, 125 V
EQ	very fast acting	Littelfuse 263, 5 A, 250 V

Input Transient Protection

A metal oxide VDR (Voltage Dependent Resistor) together with the input fuse and a symmetrical input filter form an effective protection against high input transient voltages, which typically occur in most installations, especially in battery-driven mobile applications.

Nominal battery voltages in use are: 24, 36, 48, 72, 96, and 110 V. In most cases each nominal value is specified in a tolerance band of -30% to +25%, with short excursions to ±40% or even more.

In some applications, surges according to RIA 12 are specified in addition to those defined in IEC 60571-1 or EN 50155. The power supply must not switch off during these surges, and since their energy can practically not be absorbed, an extremely wide input voltage range is required. The Q Series input ranges have been designed and tested to meet most of these requirements. See also *Electromagnetic Immunity*.

Input Under-/Overvoltage Lockout

If the input voltage falls outside the limits of V_i , an internally generated inhibit signal disables the output(s).

Inrush Current

The inherent inrush current value is lower than specified in the standard ETS 300132-2. The converters operate with relatively small input capacitance C_i (see table 4), resulting in low inrush current of short duration. As a result, in a power-bus system the converters can be hot-swapped, causing negligible disturbances.

Input Stability with Long Supply Lines

If a converter is connected to the power source by long supply lines exhibiting a considerable inductance L_{ext} , an additional external capacitor C_{ext} connected across the input pins improves the stability and prevents oscillations.

Actually, a Q Series converter with its load acts as negative resistor r_i , because the input current I_i rises, when the input voltage V_i decreases. It tends to oscillate with a resonant frequency determined by the line inductance L_{ext} and the input capacitance $C_i + C_{ext}$, damped by the resistor R_{ext} . The whole system is not linear at all and eludes a simple calculation. One basic condition is given by the formula:

$$C_i + C_{ext} > \frac{L_{ext} \cdot P_{o \max}}{R_{ext} \cdot V_{i \min}^2} \quad \left(r_i = \frac{dV_i}{dI_i} \right)$$

R_{ext} is the series resistor of the voltage source including the supply lines. If this condition is not fulfilled, the converter may not reach stable operating conditions. Worst case conditions are at lowest V_i and at highest output power P_o .

Low inductance L_{ext} of the supply lines and an additional capacitor C_{ext} are helpful. Recommended values for C_{ext} are given in table 4, which should allow for stable operation up to an input inductance of 2 mH. C_i is specified in table 4.

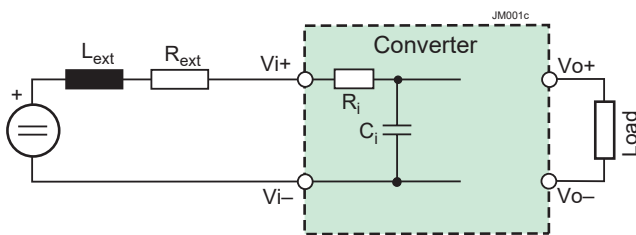

Fig. 8
Input configuration

Table 4: C_i and recommended values for C_{ext}

Model	C_i	Recomm. C_{ext}	Voltage
BQ	220 μ F	$\geq 680 \mu$ F	40 V
GQ	110 μ F	$\geq 470 \mu$ F	63 V
CQ	50 μ F	$\geq 470 \mu$ F	100 V
48Q	50 μ F	$\geq 470 \mu$ F	100 V
DQ	22 μ F	$\geq 150 \mu$ F	125 V
EQ	11 μ F	$\geq 68 \mu$ F	200 V

Electrical Output Data

General conditions:

- $T_A = 25\text{ °C}$, unless T_C is specified.
- Sense lines connected directly at the connector, inhibit (28) connected to Vi- (32).
- R input not connected; with option P, V_o set to $V_{o\text{ nom}}$ at $V_{i\text{ nom}}$.

Table 5a: Output data for single-output models and double-output models with both outputs in parallel configuration

Model		BQ – GQ1101			48Q / BQ – GQ1001			48Q / BQ – GQ2320			Unit		
Output		3.3 V			5.1 V			12 V					
Characteristics		Conditions		min	typ	max	min	typ	max	min	typ	max	
V_{o1}	Setting voltage of 1 st output	$V_{i\text{ nom}}, I_{o\text{ nom}}$		3.28		3.32	5.07		5.13	11.94		12.06	V
V_{ow}	Worst case output voltage	$V_{i\text{ min}} - V_{i\text{ max}}$		3.24		3.35	5.02		5.18	11.82		12.18	
V_{oP}	Overvoltage limitation of second control loop	$T_{C\text{ min}} - T_{C\text{ max}}, I_o = 0 - I_{o\text{ max}}$		4.5		4.9	5.9		6.4	13.5		14.3	
I_o	Output current ²	$V_{i\text{ min}} - V_{i\text{ max}}, T_{C\text{ min}} - T_{C\text{ max}}$		0.05		25	0		16/20 ³	0		8.0/10 ³	A
$I_{o\text{ nom}}$	Nominal output current					20		16		8.0			
I_{oL}	Output current limit ²			26		32.5	16.8/21 ³		20.8/26 ³	8.4/10.5 ³		10.4/12.5 ³	
V_o ⁴	Output noise	Switch. frequency	$V_{i\text{ nom}}, I_{o\text{ nom}}$		15	25		10	20		10	20	mV _{pp}
		Total incl. spikes	BW = 20 MHz		25	50		20	50		20	40	
$P_{o\text{ max}}$	Output power ¹	$V_{i\text{ min}} - V_{i\text{ max}}, T_{C\text{ min}} - T_{C\text{ max}}$			82			82/102 ³			96/120 ³		W
V_{od} ⁴	Dynamic load regulation	Voltage deviation	$V_{i\text{ nom}}$		±300			±250			±200		mV
t_d ^{4,5}		Recovery time	$I_{o\text{ nom}} \leftrightarrow \frac{1}{2} I_{o\text{ nom}}$		800		800		1500				µs
V_{oos}	Dynamic line regulation (output overshoot)		$0 \leftrightarrow V_{i\text{ max}}, 0 - I_{o\text{ max}}$			0.5			0.5			0.8	V
V_{otr}	Output voltage trim range	via R-input ¹	$1.1 \cdot V_{i\text{ min}} - V_{i\text{ max}}$		N/A		4.0		5.6	7.2		13.2	
		using opt. P ¹	$0.1 \cdot I_{o\text{ nom}} - I_{o\text{ nom}}$		N/A		4.6		5.6	10.8		13.2	
α_{vo}	Temperature coefficient of V_o		$I_{o\text{ nom}}, T_{C\text{ min}} - T_{C\text{ max}}$		±0.02			±0.02			±0.02		%/K

¹ If the output voltage is increased above $V_{o\text{ nom}}$ through R-input control, option P setting, or remote sensing, the output power should be reduced accordingly, so that $P_{o\text{ max}}$ and $T_{C\text{ max}}$ are not exceeded.

² See *Output Power at Reduced Temperature*.

³ First value for 48Q, 2nd value for BQ – GQ

⁴ Measured with a probe according to IEC/EN 61204, annex A

⁵ Recovery time see *Dynamic load regulation*.

Table 5b: Output data for double-output models with both outputs in parallel configuration. General conditions as per table 5a

Model		48Q / BQ – GQ2540			48Q / BQ – GQ2660			Unit
Output		15 V			24 V			
Characteristics		Conditions	min	typ	max	min	typ	max
V_{o1}	Setting voltage of 1 st output	$V_{i\text{nom}} / I_{o\text{nom}}$	14.93		15.08	23.88		24.12
V_{ow}	Worst case output voltage	$V_{i\text{min}} - V_{i\text{max}}$	14.78		15.23	23.64		24.36
V_{oP}	Overvoltage limitation of second control loop	$T_{C\text{min}} - T_{C\text{max}}$ $I_o = 0 - I_{o\text{max}}$	17		18	27.5		29
I_o	Output current ²		0		6.6/8.0 ³	0		4.4/5.5 ³
$I_{o\text{nom}}$	Nominal output current	$V_{i\text{min}} - V_{i\text{max}}$ $T_{C\text{min}} - T_{C\text{max}}$		6.6		4.4		
I_{oL}	Output current limit ²		6.9/8.4 ³		8.6/10.4 ³	4.6/5.8 ³		6.2/8.0 ³
V_o ⁴	Output noise	Switch. frequency	$V_{i\text{nom}} / I_{o\text{nom}}$	10	20	10	25	mV _{pp}
		Total incl. spikes	BW = 20 MHz	20	40	20	40	
$P_{o\text{max}}$	Output power ¹	$V_{i\text{min}} - V_{i\text{max}}$ $T_{C\text{min}} - T_{C\text{max}}$		99/120 ³		106/132 ³		W
V_{od} ⁴	Dynamic load regulation	Voltage deviation	$V_{i\text{nom}}$	±200		±600		mV
t_d ^{4,5}		Recovery time	$I_{o\text{nom}} \leftrightarrow 1/2 I_{o\text{nom}}$	1500		800		µs
$V_{o\text{os}}$	Dynamic line regulation (output overshoot)	$0 \leftrightarrow V_{i\text{max}}$ $0 - I_{o\text{max}}$			0.8		1.2	V
V_{otr}	Output voltage trim range	via R-input	$1.1 \cdot V_{i\text{min}} - V_{i\text{max}}$	9.0	16.5	14.4 ⁶	26.4	V
		using opt. P ¹	$0.1 \cdot I_{o\text{nom}} - I_{o\text{nom}}$ $T_{C\text{min}} - T_{C\text{max}}$	13.5	16.5	21.6	26.4	
α_{vo}	Temperature coefficient of V_o	$I_{o\text{nom}}$ $T_{C\text{min}} - T_{C\text{max}}$		±0.02		±0.02		%/K

¹ If the output voltages are increased above $V_{o\text{nom}}$ through R-input control, option P setting or remote sensing, the output power should be reduced accordingly so that $P_{o\text{max}}$ and $T_{C\text{max}}$ are not exceeded.

² See *Output Power at Reduced Temperature*.

³ First value for 48Q, 2nd value for BQ – GQ

⁴ Measured with a probe according to IEC/EN 61204, annex A

⁵ Recovery time until V_o remains within ±1% of V_{o1} , see *Dynamic load regulation*.

⁶ For DQ2660 and EQ2660: 16.8 V

Table 6a: Output data for double-output models with output 1 and output 2 in symmetrical or independent configuration.
General conditions as per table 5a.

Model			48Q /BQ – GQ2320						48Q /BQ – GQ2540						Unit		
Output			12 V / 12 V						15 V / 15 V								
Characteristics		Conditions	Output 1			Output 2			Output 1			Output 2					
			min	typ	max	min	typ	max	min	typ	max	min	typ	max			
V_o	Output setting voltage ¹		$V_{i\text{nom}}^2 / I_{o\text{nom}}$			11.94	12.06	11.88	12.12	14.93	15.08	14.85	15.15				
V_{ow}	Worst case output voltage		$V_{i\text{min}} - V_{i\text{max}}$ $T_{C\text{min}} - T_{C\text{max}}^2$			11.82	12.18	see Output Voltage Regulation			14.78	15.23	see Output Voltage Regulation				
V_{oP}	Overvoltage limitation of second control loop		$I_o = 0 - I_{o\text{max}}$			N/A			13.5	15	N/A			17	19		
I_o	Output current ²		$V_{i\text{min}} - V_{i\text{max}}$ $T_{C\text{min}} - T_{C\text{max}}$			0.8	7.2/9.2 ³	0.8	7.2/9.2 ³	0.6	6.0/7.4 ³	0.6	6.0/7.4 ³				
$I_{o\text{nom}}$	Nominal output current					4.0			3.3			3.3					
I_{oL}	Output current limit ²					8.4/10.5 ³			10.4/13 ³			6.9/8.4 ³			8.6/10.4 ³		
V_o ⁴	Output noise	Switch. frequency	$V_{i\text{nom}}^2 / I_{o\text{nom}}$			8	16	8	16	8	16	8	16	8	16		
		Total incl. spikes	BW = 20 MHz			16	40	16	40	16	40	16	40	16	40		
$P_{o\text{max}}$	Output power total ¹		$V_{i\text{min}} - V_{i\text{max}}$ $T_{C\text{min}} - T_{C\text{max}}$			96 / 120 ³						99 / 120 ³					
V_{od} ⁴	Dynamic load regulation	Voltage deviation	$V_{i\text{nom}}$			±200			±300			±200			±300		
t_d ^{4,5}		Recovery time	$I_{o\text{nom}} \leftrightarrow \frac{1}{2} I_{o\text{nom}}$ $I_{o2} = \frac{1}{2} I_{o\text{nom}}$			1500			1500			1500			1500		
V_{otr}	Output voltage trim range	via R-input	$1.1 \cdot V_{i\text{min}} - V_{i\text{max}}$			7.2	13.2	see Output Voltage Regulation			9.0	16.5	see Output Voltage Regulation				
		using opt. P	$0.1 \cdot I_{o\text{nom}} - I_{o\text{nom}}$ $T_{C\text{min}} - T_{C\text{max}}$			10.8	13.2				13.5	16.5					
α_{vo}	Temperature coefficient of V_o		$I_{o\text{nom}} / T_{C\text{min}} - T_{C\text{max}}$			±0.02			±0.02			±0.02			%/K		

¹ If the output voltages are increased above $V_{o\text{nom}}$ through R-input control, option P setting, or remote sensing, the output power should be reduced accordingly so that $P_{o\text{max}}$ and $T_{C\text{max}}$ are not exceeded.

² See Output Power at Reduced Temperature.

³ First value for 48Q, 2nd value for BQ – GQ

⁴ Measured with a probe according to IEC/EN 61204, annex A

⁵ Recovery time until V_o remains within ±1% of V_o , see Dynamic load regulation.

⁶ $I_{o\text{nom}} = I_{o1} + I_{o2}$

Table 6b: Output data for double-output models with output 1 and output 2 in symmetrical or independent configuration.
General conditions as per table 5a

Model			48Q2660						BQ – GQ2660						Unit	
Output			24 V / 24 V						24 V / 24 V							
Characteristics		Conditions	Output 1			Output 2			Output 1			Output 2				
			min	typ	max	min	typ	max	min	typ	max	min	typ	max		
V_o	Output setting voltage ¹		$V_{i\text{nom}}, I_{o\text{nom}}$			23.88	24.12	23.76	24.24	23.88	24.12	23.76	24.24	V		
V_{ow}	Worst case output voltage		$V_{i\text{min}} - V_{i\text{max}}$ $T_{C\text{min}} - T_{C\text{max}}$			23.64	24.36	see Output Voltage Regulation			23.64	24.36	see Output Voltage Regulation			
V_{oP}	Overvoltage limitation of second control loop		$I_o = 0 - I_{o\text{max}}$			N/A			27.5	30	N/A				27.5	30
I_o	Output current ²		$V_{i\text{min}} - V_{i\text{max}}$ $T_{C\text{min}} - T_{C\text{max}}$			0.4	4.0	0.4	4.0	0.4	5.1	0.4	5.1	A		
$I_{o\text{nom}}$	Nominal output current					2.2			2.2			2.2				
I_{oL}	Output current limit ²					4.6			6.2			8.0				
V_o ⁴	Output noise	Switch. frequency	$V_{i\text{nom}}, I_{o\text{nom}}$			10	25	10	25	10	25	10	25	mV _{pp}		
		Total incl. spikes	BW = 20 MHz			20	40	20	40	20	40	20	40			
$P_{o\text{max}}$	Output power total ¹		$V_{i\text{min}} - V_{i\text{max}}$ $T_{C\text{min}} - T_{C\text{max}}$			106			132			W				
V_{od} ⁴	Dynamic load regulation	Voltage deviation	$V_{i\text{nom}}$			±400			±500			mV				
t_d ^{4,5}		Recovery time	$I_{o\text{nom}} \leftrightarrow \frac{1}{2} I_{o\text{nom}}$ $I_{o2} = \frac{1}{2} I_{o\text{nom}}$			400			400			µs				
V_{otr}	Output voltage trim range	via R-input	$1.1 \cdot V_{i\text{min}} - V_{i\text{max}}$			14.4	26.4	see Output Voltage Regulation			14.4 ³	26.4	see Output Voltage Regulation		V	
		using opt. P	$0.1 \cdot I_{o\text{nom}} - I_{o\text{nom}}$ $T_{C\text{min}} - T_{C\text{max}}$			N/A			21.6			26.4				
α_{vo}	Temperature coefficient of V_o		$I_{o\text{nom}}, T_{C\text{min}} - T_{C\text{max}}$			±0.02			±0.02			±0.02			%/K	

¹ If the output voltages are increased above $V_{o\text{nom}}$ through R-input control, option P setting or remote sensing, the output power should be reduced accordingly so that $P_{o\text{max}}$ and $T_{C\text{max}}$ are not exceeded.
² See: *Output Power at Reduced Temperature*
³ For DQ2660 and EQ2660: 16.8 V
⁴ Measured with a probe according to IEC/EN 61204, annex A
⁵ Recovery time until V_o remains within ±1% of V_o , see *Dynamic load regulation*

Parallel and Series Connection

Single- or double-output models with equal output voltage can be connected in parallel without any precaution, by interconnecting the T-pins for equal current sharing; see fig. 9a.

Double-output models with their outputs connected in parallel behave exactly like single-output models and are fully regulated. There is no inconvenience or restriction using the R-input with sense lines.

Single-output and/or double-output models can be connected in series. For double-output models with both outputs connected in series, consider that the effect via sense lines, R-input or option P is doubled. See fig. 9b.

Parallel configuration of double-output models with both outputs connected in series is shown in fig. 9c. It is essential that the Vo1- pins of all paralleled converters are connected together, as the auxiliary signals are referenced to Vo1- or to S-. The effect via sense lines, R-input or option P is doubled.

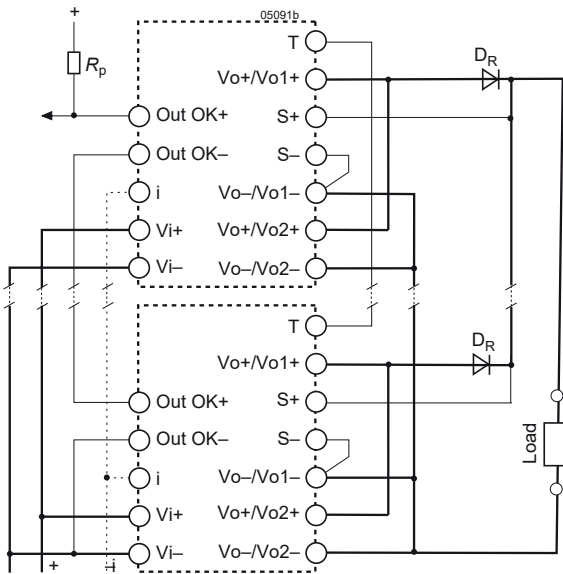

Fig. 9a
Parallel connection of single- and double-output models.

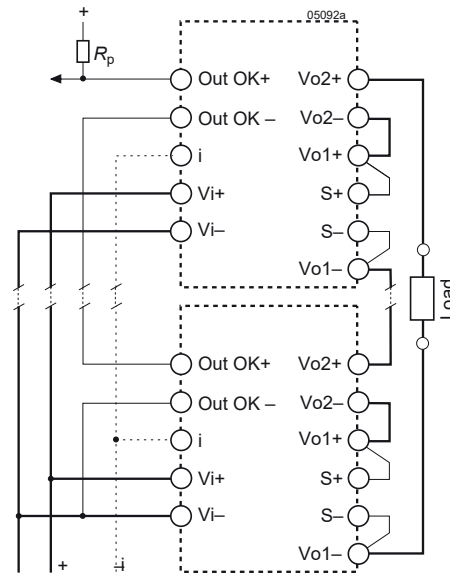

Fig. 9b
Series connection of double-output models.

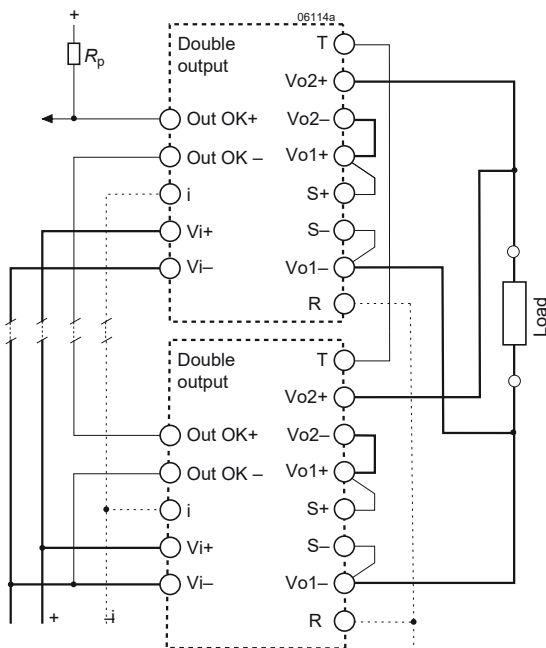

Fig. 9c
Parallel connection of double-output models with series-connected outputs.

Notes:

- If the second output of double-output models is not used, connect it in parallel to the main output to maintain good regulation.
- Parallel connection of several double-output models should always include main and second outputs to produce good regulation.
- Series connection of second outputs without involving their main outputs should be avoided as regulation may be poor.
- The maximum output current is limited by the output with the lowest current limit, if several outputs are connected in series.
- Rated output voltages above 48 V (ES1 = Energy Source class 1) need additional measures in order to comply with international safety requirements.

Redundant Configuration

Fig. 10a shows a circuit with ORing diodes D_R in the positive output lines, forming a redundant configuration. For accurate output voltage regulation, the sense lines are connected after the ORing diodes. The T pins should be connected together to produce reasonable current sharing between the parallel-connected converters.

If one of the converters fails, the remaining converters can deliver the whole output power.

Note: The current-share logic can only increase the output voltage marginally and remains functional even in the case of a failing converter.

Fig. 10b shows a quite similar circuit with ORing diodes D_R , but with different output loads. To compensate for the voltage drop of the ORing diodes (if necessary), an auxiliary circuit is added to each power supply consisting of a small diode D_s and a small resistor R_s . We recommend a current of approximately 10 mA through D_s and R_s . Only Load 0 benefits from a secured supply voltage.

The current sharing may be improved by interconnecting the T pins of the converters. This circuit is a bit less accurate, but more flexible and less sensitive.

Caution: Do not connect the sense lines **after** the ORing diodes, but directly with the respective outputs. If for some reason one of the converters switches off and the ORing diode is blocking, a reverse voltage can appear between the sense pin and the respective output pin and damage the converter.

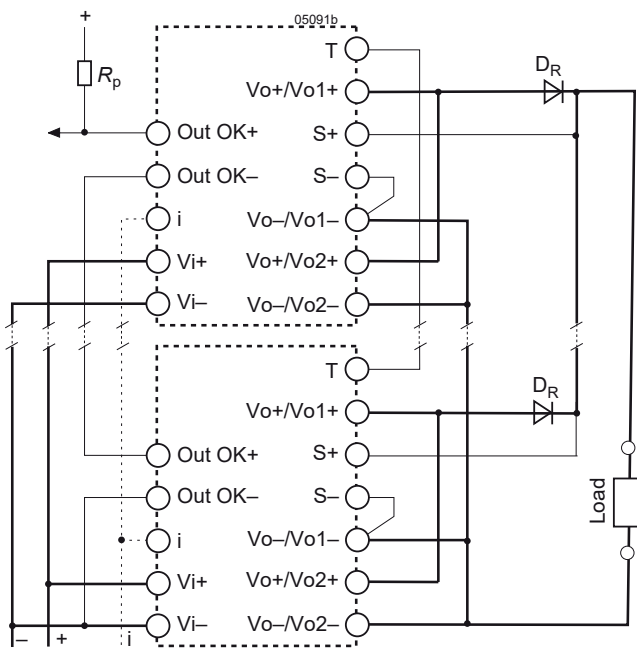

Fig. 10a
Simple redundant configuration of double-output models with parallel-connected outputs.

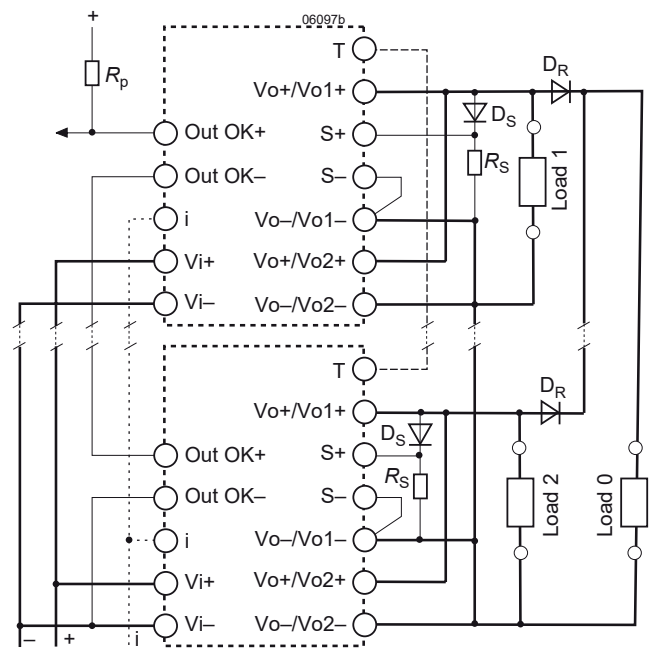

Fig. 10b
Redundant configuration of double-output models with parallel-connected outputs.

Output Voltage Regulation

The dynamic load regulation is shown in figure 11.

The static load regulation measured at the sense pins is negligible. Correct connection of the sense lines almost eliminates any load regulation; see *Sense Lines*.

In a symmetrical configuration the output 1 with open R input is regulated to $V_{o1\text{nom}}$, regardless of the output currents. If the load on output 2 is too small (<10% of $I_{o\text{nom}}$), its voltage will rise and may activate the overvoltage protection, which will then reduce the voltage on both outputs.

V_{o2} depends upon the load distribution: If each output is loaded with at least 10% of $I_{o\text{nom}}$, the deviation of V_{o2} remains within $\pm 5\%$ of $V_{o\text{nom}}$. The following figures explain the regulation with different load distributions up to the current limit. If $I_{o1} = I_{o2}$ or the two outputs are connected in series, the deviation of V_{o2} remains within $\pm 1\%$ of the value of $V_{o\text{nom}}$, provided that the load is at least $I_{o\text{min}}$.

Note: If output 2 is not used, we recommend to connect it in parallel to Vo1. This results in improved efficiency and stability.

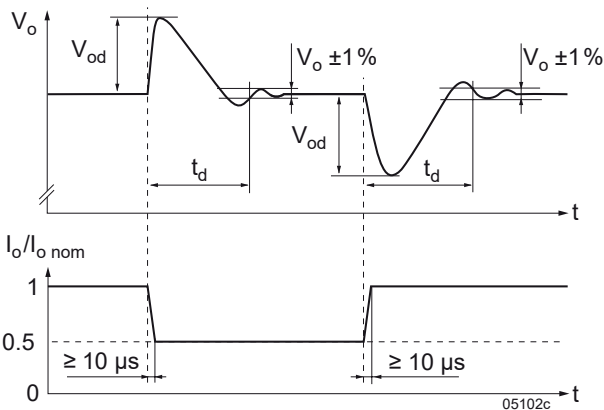

Fig. 11
Deviation of V_o versus dynamic load change

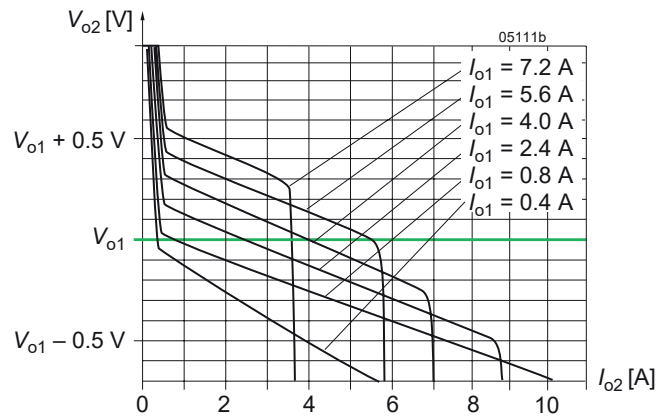

Fig. 12
Double-output models with 12 V: Voltage deviation of V_{o2} versus I_{o2} for different currents on output 1

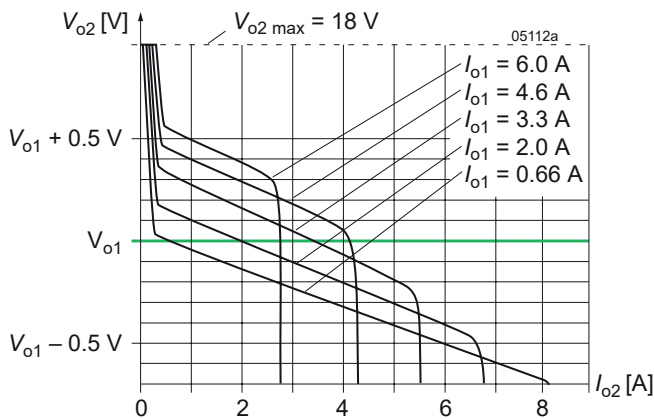

Fig. 13
Double-output models with 15 V: Voltage deviation of V_{o2} versus I_{o2} for different currents on output 1

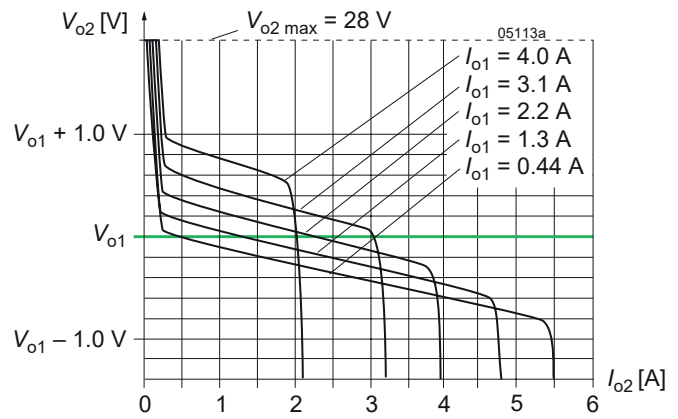

Fig. 14
Double-output models with 24 V: Voltage deviation of V_{o2} versus I_{o2} for different currents on output 1

Output Overvoltage Protection

Output voltage overshoot may occur, if the converter is either hot plugged-in or disconnected, the input voltage is switched on or off, the converter is switched with an inhibit signal, or after a reset of a short circuit and power failure. Output overvoltage can also result due to incorrectly wired sense lines.

A fully independent output voltage monitor (second control loop) limits the voltage V_o or V_{o2} to approximately $1.25 \cdot V_{o\text{nom}}$ (in double-output models, the 2nd output is monitored). This circuitry further protects the load in the unlikely event of a malfunction of the main control circuit.

There is no specific built-in protection against externally applied overvoltage.

Note: If output 2 is not loaded, the 2nd control loop may reduce V_{o1} under boundary conditions.

Output Current Protection

All outputs are fully protected against continuous open-circuit condition or continuous short-circuit by an electronic current limitation located on the primary side.

Single-output models and series- or parallel-connected double-output models have a quasi rectangular constant current limitation characteristic.

In double-output models, only the total current is limited, allowing free choice of load distribution between the two outputs, up to $I_{o1} + I_{o2} \leq I_{o\ max}$. However, a small current should remain on both outputs to guarantee good voltage regulation. In case of overload ($I_{o1} + I_{o2} > I_{o\ max}$) both output voltages are reduced simultaneously.

Current distribution in overload is dependent upon the type of overload. A short-circuit in one output will cause the full current flow into that output, whereas a resistive overload results in more even distribution and in a reduced output voltage.

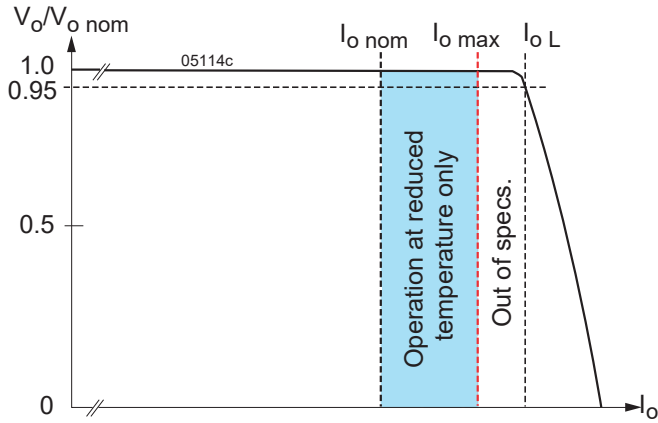

Fig. 15a
BQ – GQ models: Current limitation of single- or double-output models with series-connected outputs (no opt. B or B1)

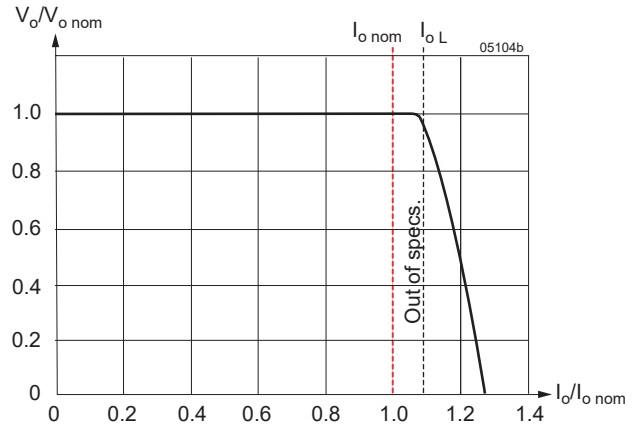

Fig. 15b
48Q models: Current limitation of single- or double-output models with series-connected outputs (no opt. B or B1)

Efficiency

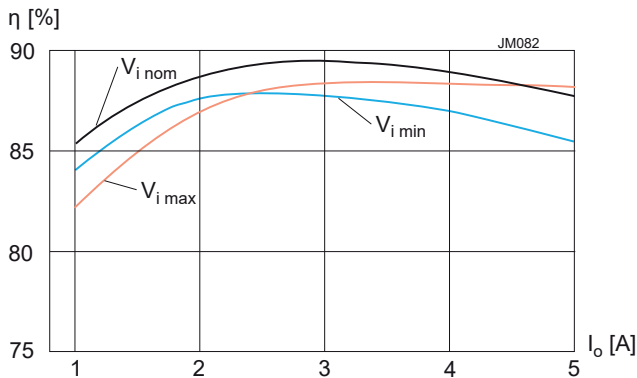

Fig. 16a
Efficiency versus input voltage and current per output (BQ2320)

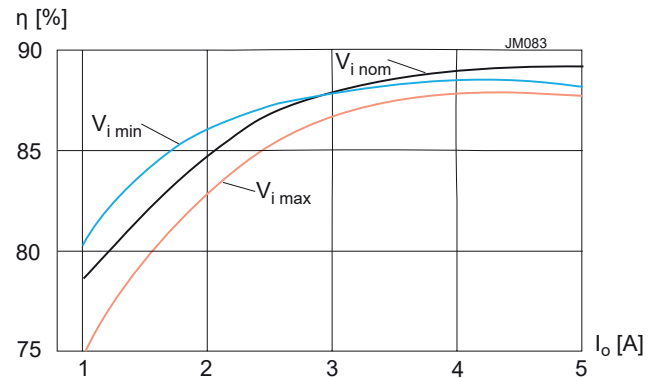

Fig. 16b
Efficiency versus input voltage and current per output (EQ2320)

Hold-up Time

The Q Series converters provide virtually no hold-up time. If hold-up time or interruption time is required, use external output capacitors or decoupling diodes together with input capacitors of adequate size.

Formula for additional external input capacitor:

$$C_{i\text{ext}} = \frac{2 \cdot P_o \cdot t_h \cdot 100}{\eta \cdot (V_{ti}^2 - V_{i\text{min}}^2)}$$

where as:

- $C_{i\text{ext}}$ = external input capacitance [mF]
- P_o = output power [W]
- η = efficiency [%]
- t_h = hold-up time [ms]
- $V_{i\text{min}}$ = minimum input voltage [V]
- V_{ti} = threshold level [V]

Thermal Considerations and Protection

If a converter is located upright in quasi-stationary air (convection cooling) at the indicated maximum ambient temperature $T_{A\text{max}}$ (see table *Temperature specifications*), and is operated at its nominal input voltage and output power, the temperature T_C measured at the *Measuring point of case temperature* (see *Mechanical Data*) will approach $T_{C\text{max}}$ after the warm-up phase. However, the relationship between T_A and T_C depends heavily on the operating conditions and the integration into a system. The thermal conditions are influenced by input voltage, output current, airflow, and temperature of surrounding components and surfaces. $T_{A\text{max}}$ is therefore, contrary to $T_{C\text{max}}$, an indicative value only.

Caution: The installer must ensure that under all operating conditions T_C remains within the limits stated in the table *Temperature specifications*.

Note: Sufficient forced cooling or an additional heat sink improves the reliability or allows T_A to be higher than $T_{A\text{max}}$, as long as $T_{C\text{max}}$ is not exceeded. In rack systems without proper thermal management, the converters must not be packed too densely! In such cases the use of a 5 or 6 TE front panel is recommended.

A temperature sensor generates an internal inhibit signal, which disables the outputs, if the case temperature exceeds $T_{C\text{max}}$. The outputs are automatically re-enabled when the temperature drops below this limit. This feature is not fitted to 48Q models.

Operating BQ – GQ models with output current beyond $I_{o\text{nom}}$ requires a reduction of the ambient temperature T_A to 50 °C or forced cooling. When $T_{C\text{max}}$ is exceeded, the converter runs into its thermal protection and switches off; see fig. 17a.

Note: According to EN 50155, Class OT4, the converters BQ – GQ can be operated with $P_{o\text{nom}}$ continuously at $T_A = 70$ °C, and then for 10 min at $T_A = 85$ °C without shutdown.

Fig. 17b shows the operation of 48Q models beyond $T_A = 50$ °C with forced cooling.

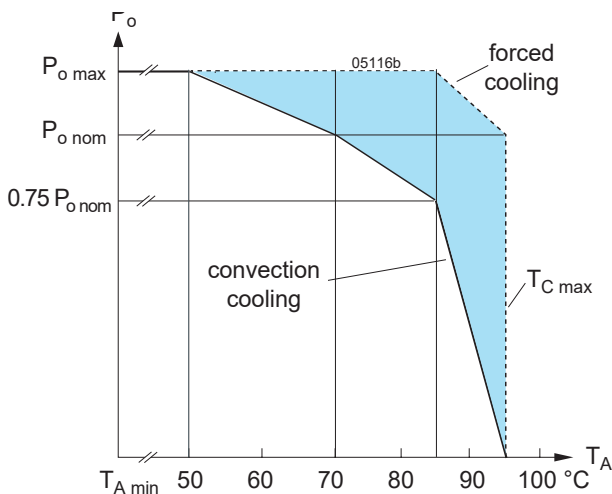

Fig. 17a
Output power derating versus T_A for BQ – GQ models

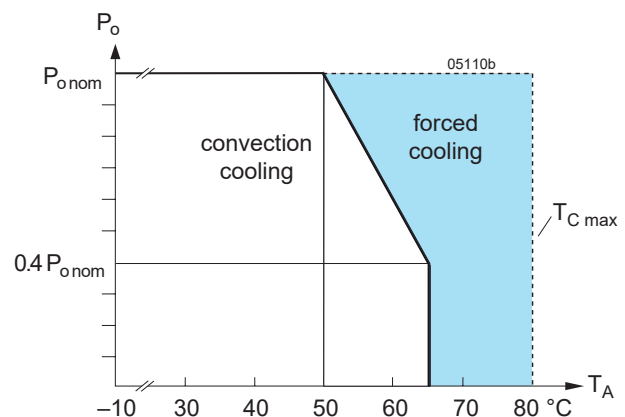

Fig. 17b
Output power derating versus T_A for 48Q models

Auxiliary Functions

Inhibit for Remote On/Off

Note: If this function is not used, the inhibit pin 28 must be connected with pin 32 to enable the output(s). A non-connected pin 28 will be interpreted by the internal logic as an active inhibit signal and the output(s) will remain disabled (fail safe function).

An inhibit input enables (logic low, pull down) or disables (logic high, pull up) the output, if a logic signal, e.g. TTL, CMOS is applied. In systems consisting of several converters, this feature may be used, for example, to control the activation sequence of the converters by means of logic signals, or to allow the power source for a proper start-up, before full load is applied.

Table 7: Inhibit characteristics

Characteristics		Conditions	min	typ	max	Unit
V_{inh}	Inhibit voltage	$V_o = \text{on}$	$V_{i \min} - V_{i \max}$	-50	0.8	V
		$V_o = \text{off}$	$T_{C \min} - T_{C \max}$	2.4	50	
I_{inh}	Inhibit current	$V_{inh} = -50 \text{ V}$		-500		μA
		$V_{inh} = 0 \text{ V}$		-40		
		$V_{inh} = 50 \text{ V}$		+500		

The output response, when enabling and disabling the output by the inhibit input, is shown in figure 19.

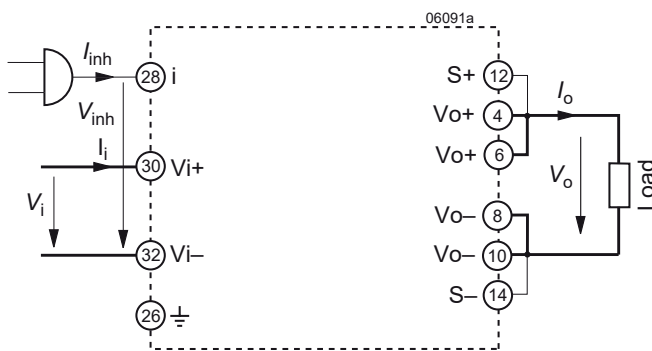

Fig. 18
Definition of input and output parameters

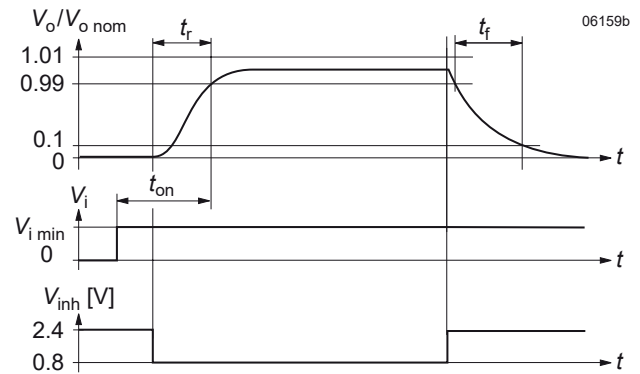

Fig. 19
Output response as a function of V_i (on/off switching) or inhibit control

Table 8: Inhibit response times (typ. values, outputs with ohmic load, R-input left open-circuit)

Characteristics		Conditions	BQ	48Q	CQ	GQ	DQ*	EQ*	Unit
t_r	Output voltage rise time (indicative values)	$V_{i \text{ nom}}, R_L = V_{o \text{ nom}} / I_{o \text{ nom}}$ $V_{inh} = 2.4 \rightarrow 0.8 \text{ V}$	1.5	1.3	1.3	1.5	1.5	1.6	V
t_f $V_{i \min}$	Output voltage fall time (indicative values)	$V_{i \text{ nom}}, R_L = V_{o \text{ nom}} / I_{o \text{ nom}}$	0.5	0.5	0.5	0.5	0.5	0.5	μA
		$V_{inh} = 0.8 \rightarrow 2.4 \text{ V}$	0.8	0.6	0.6	0.8	0.7	0.7	
		12 / 15 V 24 V	1.3	1.2	1.3	1.5	1.1	1.5	
			3	3	3	3	3	3	

* Models with version V104 or higher

Current Sharing

The current sharing facility should be used when several converters are operated in parallel or redundant connection. This feature avoids that some converters are driven into current limitation and thus produce excessive losses. As a result, the stress of the converters is reduced, and the system reliability is further improved.

Simple interconnection of the T pins causes the converters to share the output current. The current tolerance of each converter is approx. ±20% of the sum of its nominal output currents $I_{o1\text{ nom}} + I_{o2\text{ nom}}$.

In n+1 redundant systems, a failure of a single converter will not lead to a system failure, if the outputs are decoupled by diodes; see fig. 10.

Note: T-function only increases the output voltage, until the currents are evenly shared. If in a redundant system, one converter fails, the remaining converters keep sharing their currents evenly.

Since the T pins are referenced to the pins S–, the S– pins of all converters must have the same electrical potential.

Double-output converters with both outputs connected in series can also be paralleled with current sharing, if pins Vo1– of all converters are connected together, see fig. 9c.

If the output voltages are programmed to a voltage other than $V_{o\text{ nom}}$ by means of the R pin or option P, the outputs should be adjusted individually within a tolerance of ±1%.

Important: For applications using the hot-swap capabilities, dynamic output voltage changes during plug-in/plug-out must be considered.

Programmable Output Voltage (R-Function)

This feature is not available on models with 3.3 V output or with option P.

Note: Models with 3.3 V output or with option P: The R-input must be left open-circuit.

The converters offer a programmable output voltage. The adjust is performed either by an external control voltage V_{ext} or an external resistor R_1 or R_2 , connected to the R-input. Trimming is limited to the values given in the table below (see also *Electrical Output Data*). With open R-input, the output voltage is set to $V_{o\text{ nom}}$.

With double-output models, both outputs are affected by the R-input settings.

If output voltages are set higher than $V_{o\text{ nom}}$, the output currents should be reduced accordingly, so that the maximum specified output power is not exceeded.

a) Adjustment by means of an external control voltage V_{ext} between R (pin 16) and S– (pin 14); see fig. 20.

$$V_{\text{ext}} \approx 2.5 \text{ V} \cdot \frac{V_o}{V_{o\text{ nom}}} \quad V_o \approx V_{o\text{ nom}} \cdot \frac{V_{\text{ext}}}{2.5 \text{ V}}$$

Caution: To prevent damage, V_{ext} should not exceed 20 V, nor be negative.

b) Adjustment by means of an external resistor:

The resistor can either be connected:

- between R (pin 16) and S– (pin 14) to set $V_o < V_{o\text{ nom}}$, or
- between R (pin 16) and S+ (pin 12) to set $V_o > V_{o\text{ nom}}$.

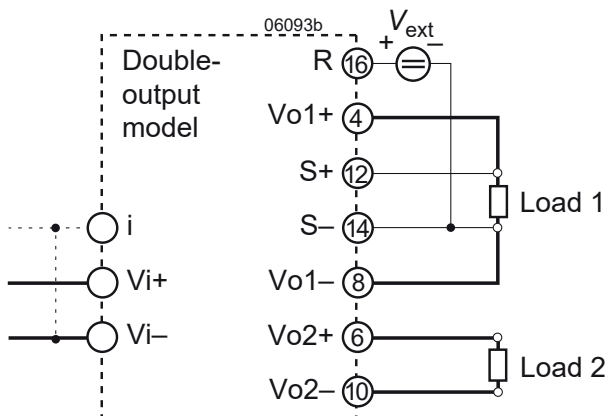

Fig. 20 Output adjust using an external control voltage V_{ext}

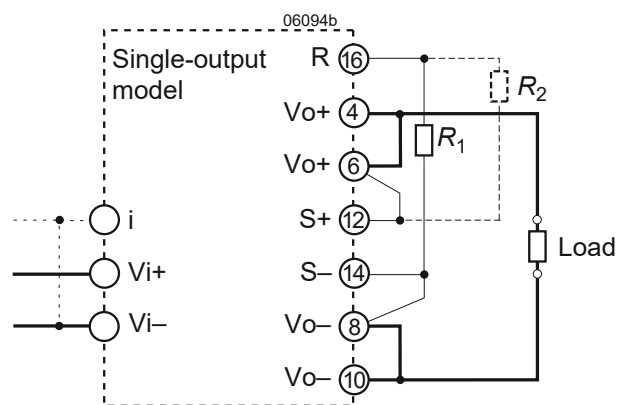

Fig. 21 Output adjust using a resistor R_1 (to lower V_o) or R_2 (to increase V_o).

Table 9a: R_1 for $V_o < V_{o\text{ nom}}$; approximate values ($V_{i\text{ nom}}$, $I_{o\text{ nom}}$, series E 96 resistors); $R_2 = \text{not fitted}$

$V_{o\text{ nom}} = 5.1\text{ V}$		$V_{o\text{ nom}} = 12\text{ V}$			$V_{o\text{ nom}} = 15\text{ V}$			$V_{o\text{ nom}} = 24\text{ V}$		
V_o [V]	R_1 [kΩ]	V_o [V] ¹		R_1 [kΩ]	V_o [V] ¹		R_1 [kΩ]	V_o [V] ¹		R_1 [kΩ]
4.0	14.7				9	18	6.04	15 ²	30.0 ²	6.65 ²
4.1	16.5							16 ²	32.0 ²	8.06 ²
4.2	18.2	7	14	5.62	9.5	19	6.98	17 ²	34.0 ²	9.76 ²
4.3	21.5	7.5	15	6.65	10	20	8.06	18 ²	36.0 ²	12.1
4.4	25.5	8	16	8.06	10.5	21	9.31	19	38.0	15.4
4.5	30.1	8.5	17	9.76	11	22	11	20	40.0	20.0
4.6	37.4	9	18	12.1	11.5	23	13.3	20.5	41.0	23.7
4.7	47.5	9.5	19	15.4	12	24	16.2	21	42.0	28.0
4.8	64.9	10	20	20	12.5	25	20	21.5	43.0	34.8
4.9	97.6	10.5	21	28	13	26	26.1	22	44.0	44.2
5.0	200	11	22	44.2	13.5	27	36.5	22.5	45.0	60.4
		11.5	23	93.1	14	28	56.2	23	46.0	90.9
					14.5	29	115	23.5	47.0	190

Table 9b: R_2 for $V_o > V_{o\text{ nom}}$; approximate values ($V_{i\text{ nom}}$, $I_{o\text{ nom}}$, series E 96 resistors); $R_1 = \text{not fitted}$

$V_{o\text{ nom}} = 5.1\text{ V}$		$V_{o\text{ nom}} = 12\text{ V}$			$V_{o\text{ nom}} = 15\text{ V}$			$V_{o\text{ nom}} = 24\text{ V}$		
V_o [V]	R_2 [kΩ]	V_o [V] ¹		R_2 [kΩ]	V_o [V] ¹		R_2 [kΩ]	V_o [V] ¹		R_2 [kΩ]
5.2	215	12.2	24.4	931	15.3	30.6	1020	24.5	49	1690
5.3	110	12.4	24.8	475	15.5	31	619	25	50	866
5.4	75	12.6	25.2	316	15.7	31.4	453	25.5	51	590
5.5	57.6	12.8	25.6	243	16.0	32	316	26	52	442
5.6	46.4	13.0	26.0	196	16.2	32.4	267	26.4	52.8	374
		13.2	26.4	169	16.5	33	221			

¹ First column: single or double output models with separated/paralleled outputs, second column: outputs in series connection.

² Not possible for DQ2660 and EQ2660.

Output Good Signal (Out-OK)

The isolated Out-OK output gives a status indication of the converter and the output voltage. It can be used for control functions such as data protection, central system monitoring or as a part of a self-testing system. It can be connected to get a centralized fault detection or may be used for other system-specific applications at the primary or the secondary side of the converter.

Connecting the Out-OK as per fig. 22, $V_{OK} < 1.0\text{ V}$ indicates that the V_o or V_{o1} of the converter is within the range $V_{t1\text{ low}} - V_{t1\text{ high}}$. $V_{t1\text{ low}}$ corresponds to $0.95 - 0.98 V_{o1\text{ nom}}$, $V_{t1\text{ high}}$ to $1.02 - 1.05 V_{o1\text{ nom}}$.

Note: Using the R-input or the option P, the monitor level is tracking the programmed output voltage.

In an error condition, if the output voltage is out of range due to overload or an external overvoltage, V_{OK} will approach V_p .

The output is formed by an NPN transistor. The emitter (Out OK-) can be connected to primary V_{i-} or secondary V_{o1-} to get an open-collector output. In a configuration of several Q Series converters, the Out OK pins can be series-connected in order to get a system level signal (as shown in fig. 9). If one of the converters fails, the series-connected output rises to high impedance.

Dimensioning of resistor value $R_p \geq \frac{V_p}{0.5\text{ mA}}$

Caution: Out-OK is protected by an internal series resistor and a Zener diode. To prevent damage, the applied current I_{OK} should be limited to $\pm 10\text{ mA}$.

Table 10: Out-OK data

Characteristics	Conditions	min	typ	max	Unit
V_{OK}	Out-OK voltage		0.8	1.0	V
I_{OK}	Out-OK current			25	μA

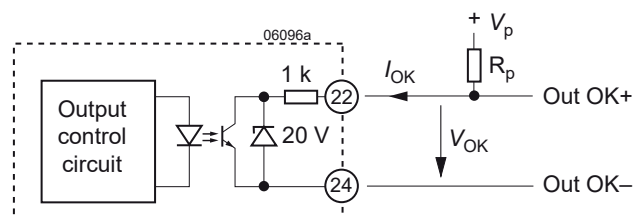

Fig. 22
Out OK function

Sense Lines

This feature allows for compensation of voltage drops at the main output across connector contacts and load lines. If the sense lines are connected at the load rather than directly at the connector, the user must ensure that the differential voltages (measured on the connector) ΔV_{S+} (between Vo+ and S+) and ΔV_{S-} (between Vo- and S-) do not exceed the values in the table 11.

Table 11: Voltage compensation by sense lines

Nominal output voltage	ΔV_{S+}	ΔV_{S-}	Sum of $\Delta V_{S+} + \Delta V_{S-}$	Unit
3.3 V, 5.1 V	≤ 0.5	≤ 0.25	≤ 0.5	
12 V, 15 V	≤ 1.0	≤ 0.5	≤ 1.0	V
24 V	≤ 1.0	≤ 1.0	≤ 2.0	

Applying generously dimensioned cross-section load leads help avoiding troublesome voltage drops. To minimize noise pick-up, wire the sense lines parallel or twisted. For unsymmetrical loads, we recommend connecting the sense lines directly at the female connector.

To ensure correct operation, both sense lines must be connected to their respective power output. With double-output models, the sense lines must be connected to output 1 only. Caution should be exercised, if outputs are series-connected, as the compensated voltage is effectively doubled. Because the effective output voltage and output power are increased by the sense lines, the minimum input voltage rises proportionally to the compensated output voltage.

Caution: Sense lines should always be connected. Incorrectly connected sense lines may cause an overvoltage at the output, which could damage the output load and activate the second control loop. The sense lines can handle only small currents.

Note: Sense line connection in a redundant configuration is shown in fig. 10.

Test Sockets and LEDs

Test jacks (for pin diameter 2 mm) are located at the front of the converter and allow monitoring the main output voltage at the sense line terminals. The test sockets are protected by internal series resistors. Double-output models show the sense line voltage of output 1 at the test jacks. 48Q models have no test sockets.

48Q models exhibit a green LED In-OK to monitor the input voltage. BQ – GQ models have an additional LED Out-OK, which is activated simultaneously to the Out-OK signal.

Table 12: Display status of LEDs

LED In OK	LED Out OK	Operating condition
green	green	normal operation
green	x	incorrect sense line connection
green	off	overtemperature overload output overvoltage output undervoltage
off	green	not possible
off	off	no input voltage input voltage too low input voltage too high inhibit input open/high

x = dependent on actual operating condition

Electromagnetic Compatibility (EMC)

A metal oxide VDR together with an input fuse and a symmetrical input filter form an effective protection against high input transient voltages, which typically occur in most installations, especially in battery-driven mobile applications. The Q Series has been successfully tested to the following specifications:

Electromagnetic Immunity

Table 13: Electromagnetic immunity (type tests)

Phenomenon	Standard	Level	Coupling mode ¹	Value applied	Waveform	Source impeded.	Test procedure	In oper.	Perf. crit. ²
Supply related surge	RIA 12 ³	B	+i/-i	$1.5 \cdot V_{Bat}$	0.1/1/0.1 s	0.2 Ω	1 positive surge	yes	A
	EN 50155:2017 13.4.3			$1.4 \cdot V_{Bat}$					
Direct transients	RIA 12	D	-i/c, +i/-i	$\pm 1800 V_p$	5/50 μs	5 Ω	5 pos. & 5 neg. impulses	yes	A
		G		$\pm 8400 V_p$	0.05/0.1 μs				
Indirect couples transients		H	-o/c, +o/-o, -o/-i	$1800 V_p$	5/50 μs	100 Ω			
		L		$8400 V_p$	0.05/0.1 μs				
Electrostatic discharge (to case)	IEC/EN 61000-4-2	4 ⁴	contact discharge	$8000 V_p$	1/50 ns	330 Ω 150 pF	10 pos. & 10 neg. discharges	yes	A
			air discharge	$15000 V_p$					
Electromagnetic field	IEC/EN 61000-4-3	x ⁵	antenna	20 V/m	AM 80% / 1 kHz	N/A	80 – 1000 MHz	yes	A
		6	antenna	20 V/m	AM 80% / 1 kHz	N/A	800 – 1000 MHz		
				10 V/m			1400 – 2000 MHz		
				5 V/m			2000 – 2500 MHz		
3 V/m	5100 – 6000 MHz								
Electrical fast transients / burst	IEC/EN 61000-4-4	3 ⁷	direct coupl. (fig. 9)	$\pm 2000 V_p$ ⁷	bursts of 5/50 ns; 5 kHz over 15 ms; burst period: 300 ms	50 Ω	60 s positive 60 s negative transients per coupling mode	yes	A
		4	+i/c, -i/c, +i/-i	$\pm 4000 V_p$				yes	B
		3	capacit. (fig. 10), o/c	$\pm 2000 V_p$				yes	B
Surges	IEC/EN 61000-4-5	3 ³	+i/c, -i/c	$\pm 2000 V_p$ ³	1.2 / 50 μs	42 Ω / 0.5 μF	5 pos. & 5 neg. surges per coupling mode	yes	A
			+i/-i	$1000 V_p$ ³					
	FTZ 19 Pfl 1	10	+i/-i	$150 V_p$	0.1/0.3 ms	<100 A	3 pos. 5 repetitions	yes	A
Conducted disturbances	IEC/EN 61000-4-6	3 ⁸	i, o, signal wires	10 VAC (140 dBμV)	AM 80% / 1 kHz	150 Ω	0.15 – 80 MHz	yes	A
Power frequency magnetic field	IEC/EN 61000-4-8	11	-	100 A/m			60 s in all 3 axes	yes	A

¹ i = input, o = output, c = case.

² A = normal operation, no deviation from specs; B = temporary loss of function or deviation from specs possible

³ Measured with an external input cap specified in table 4. Exceeds EN 50121-3-2:2016 table 3.3 and EN 50121-4:2016 table 4.3.

⁴ Exceeds EN 50121-3-2:2016 table 5.3 and EN 50121-4:2016 table 2.1.

⁵ Corresponds to EN 50121-3-2:2016 table 5.1 and exceeds EN 50121-4:2016 table 1.1.

⁶ Corresponds to EN 50121-3-2:2016 table 5.2 and EN 50121-4:2016 table 2.2

⁷ Corresponds to EN 50121-3-2:2016 table 3.2 and EN 50121-4:2016 table 4.2.

⁸ Covers or exceeds EN 50121-3-2:2016 table 3.1 and EN 50121-4:2016 table 4.3 (radio frequency common mode).

⁹ Corresponds to EN 50121-4:2016 table 2.3.

¹⁰ Valid for 48Q and CQ only.

Electromagnetic Emissions

All **conducted emissions** (fig. 23) have been tested according to EN 55011, group 1, class A (similar to EN 55032). These limits are much stronger than requested in EN 50121-3-2:2016, table 2.1 and correspond to EN 50121-4:2016, table 1.1. The limits in fig. 23 apply to quasipeak values, which are always lower than peak values.

In addition, the values for average must keep a limit 10 dBµV below the limits in fig. 23 (not shown).

Radiated emissions have been tested according to EN 55011 group 1, class A. These limits are similar to the requirements of EN 50121-3-2:2016 and EN 50121-4:2016 calling up EN 61000-6-4+A1:2011, table 1. The test is executed with horizontal and vertical polarization. The worse result is shown in fig. 24.

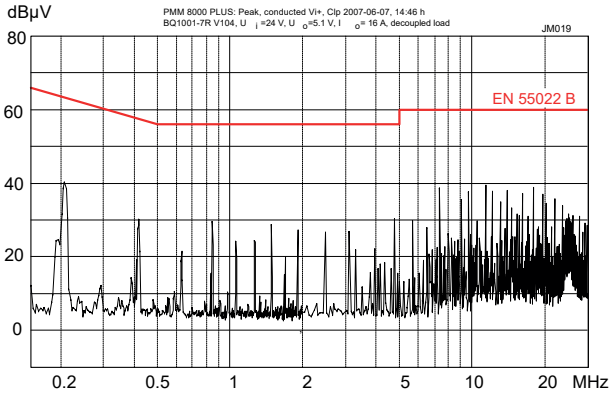

Fig. 23a
Conducted peak disturbances at the input: BQ1001-7R V104, $V_{i,nom}$, $I_{o,nom}$ decoupled load lines

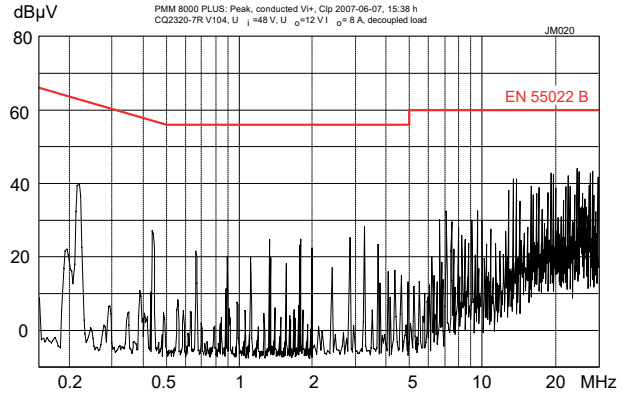

Fig. 23b
Conducted peak disturbances at the input: CQ2320-7R V104, $V_{i,nom}$, $I_{o,nom}$ outputs parallel connected, decoupled load lines

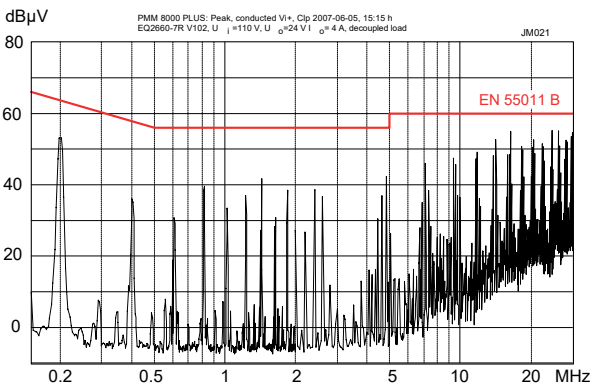

Fig. 23c
Conducted peak disturbances at the input: EQ2660-7R V102, $V_{i,nom}$, $I_{o,nom}$ outputs parallel connected, decoupled load lines

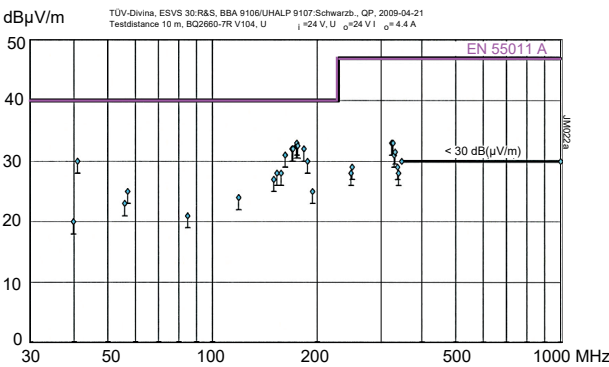

Fig. 24a
Radiated disturbances in 10 m distance: BQ2660-7R V104, $V_{i,nom}$, $I_{o,nom}$

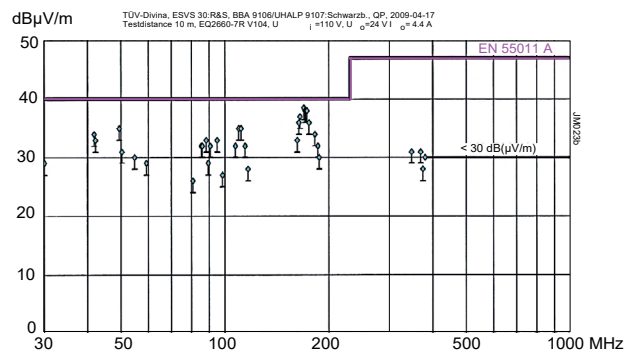

Fig. 24b
Radiated disturbances in 10 m distance: EQ2660-7R V104, $V_{i,nom}$, $I_{o,nom}$

Immunity to Environmental Conditions

Table 14: Mechanical and climatic stress

Test method		Standard	Test Conditions	Status
Cab	Damp heat steady state	IEC/EN 60068-2-78 MIL-STD-810D section 507.2	Temperature: 40 ^{±2} °C Relative humidity: 93 ^{+2/-3} % Duration: 56 days	Converter not operating
Db	Damp heat test, cyclic	EN 50155:2017, clause 13.4.7 IEC/EN 60068-2-30	Temperature: 55 °C and 25 °C Cycles (respiration effect) 2 Duration: 2x 24 h	Converter not operating
Be	Dry heat test steady state	EN 50155:2017, clause 13.4.5 ST1, IEC/EN 60068-2-2	Temperature: 70 °C (85 °C) Duration: 6 h (10 min)	Converter operating
Ad	Cooling test steady state	EN 50155:2017, clause 13.4.4 IEC/EN 60068-2-1	Temperature, duration: -40 °C, 2 h Performance test: +25 °C	Converter not operating
Ka	Salt mist test sodium chloride (NaCl) solution	EN 50155:2017, clause 13.4.10 IEC/EN 60068-2-11	Temperature: 35 ^{±2} °C Duration: 48 h	Converter not operating
Fc	Vibration (sinusoidal)	IEC/EN 60068-2-6 MIL-STD-810D section 514.3	Acceleration amplitude: 0.35 mm (10 – 60 Hz) 5 g _n = 49 m/s ² (60 - 2000 Hz) Frequency (1 Oct/min): 10 – 2000 Hz Test duration: 7.5 h (2.5 h in each axis)	Converter operating
Fh	Random vibration broad band (digital control) & guidance	IEC/EN 60068-2-64	Acceleration spectral density: 0.05 g _n ² /Hz Frequency band: 8 – 500 Hz Acceleration magnitude: 4.9 g _{n,rms} Test duration: 1.5 h (0.5 h in each axis)	Converter operating
Ea	Shock (half-sinusoidal)	IEC/EN 60068-2-27 MIL-STD-810D section 516.3	Acceleration amplitude: 50 g _n = 490 m/s ² Bump duration: 11 ms Number of bumps: 18 (3 in each direction)	Converter operating
	Shock	EN 50155:2017, clause 13.4.11 EN 61373 sect. 10 class B, body mounted ¹	Acceleration amplitude: 5.1 g _n Bump duration: 30 ms Number of bumps: 18 (3 in each direction)	Converter operating
	Simulated long life testing at increased random vibration levels	EN 50155:2017, clause 13.4.11 EN 61373 sect. 8 and 9 class B, body mounted ¹	Acceleration spectral density: 0.02 g _n ² /Hz Frequency band: 5 – 150 Hz Acceleration magnitude: 0.8 g _{n,rms} Test duration: 15 h (5 h in each axis)	Converter operating

¹ Body mounted = chassis of a railway coach

Temperatures

Table 15: Temperature specifications, valid for an air pressure of 800 – 1200 hPa (800 – 1200 mbar)

Model			-2			-7 (Option)			-9			Unit
Characteristics		Conditions	min	typ	max	min	typ	max	min	typ	max	
T_A	Ambient temperature	Converter operating	- 10		50	- 25		71 ¹	- 40		71 ¹	° C
T_C	Case temperature		- 10		80	- 25		95 ^{1,2}	- 40		95 ^{1,2}	
T_S	Storage temperature	Not operational	- 25		85	- 40		85	- 55		85	

¹ See *Thermal Considerations*. Operation with $P_{o\max}$ requires a reduction to $T_{A\max} = 50\text{ °C}$ and $T_{C\max} = 85\text{ °C}$.

² Overtemperature lockout at $T_C > 95\text{ °C}$ (PTC).

Reliability

Table 16: MTBF and device hours

Ratings at specified case temperature	Model	Ground benign 40 °C	Ground fixed		Ground mobile 50 °C	Naval, sheltered 40 °C	Device hours ¹	Unit
			40 °C	70 °C				
MTBF according to MIL-HDBK-217F	CQ1000	588 000	196 000	96 000	74 000		6 400 000	h
MTBF according to MIL-HDBK-217F, notice 2	BQ1001-9R	908 000	243 000	160 000	98 000	192 000		
	EQ2660-9R	913 000	237 000	155 000	97 000	188 000		

¹ Statistical values, based on an average of 4300 working hours per year and in general field use over 5 years; upgrades and customer-induced errors are excluded.

Mechanical Data

The converters are designed to be inserted in a 19" rack according to IEC 60297-3. Dimensions in mm.

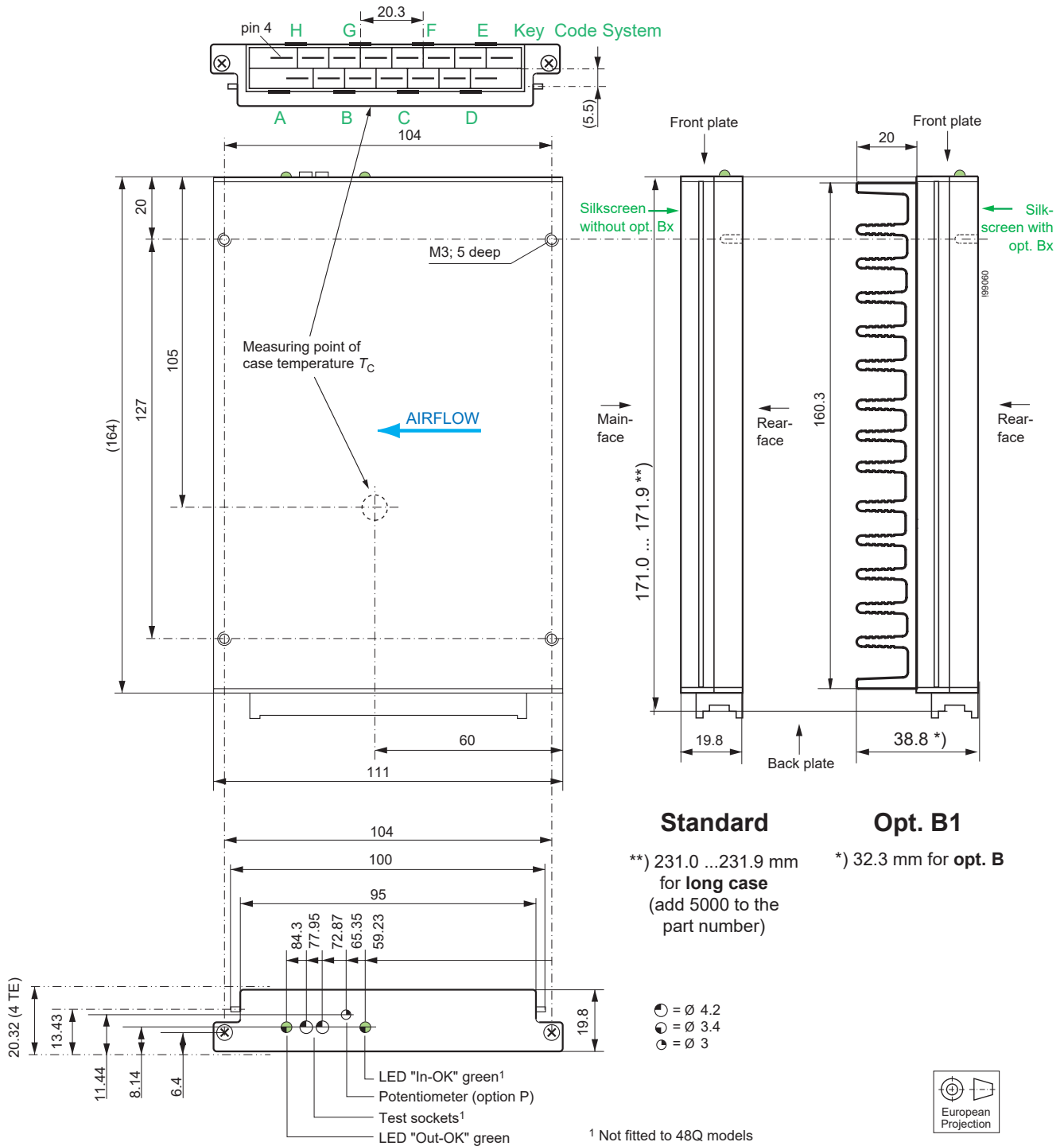

Fig. 25
Case Q01, weight approx. 500g;
Aluminum, fully enclosed, black finish, EP powder coated, self cooling

Notes:



Long case, elongated by 60 mm for 220 mm rack depth is available on request. Add 5000 to the standard part number.
An additional heat sink (option B1) is available; it reduces the case temperature T_C , and allows more output power at higher ambient temperature T_A .

Safety and Installation Instructions

Connector Pin Allocation

The connector pin allocation table defines the electrical potentials and the physical pin positions on the H15 connector. Pin no. 26, the protective earth pin, is a leading pin, ensuring that it makes contact with the female connector first.

Table 17: Pin allocation of the H15 connector

Pin	Electrical determination	Q1000	Q2000
4	Output voltage (positive)	Vo+	Vo1+
6	Output voltage (positive)	Vo+	Vo2+
8	Output voltage (negative)	Vo-	Vo1-
10	Output voltage (negative)	Vo-	Vo2-
12	Sense line (positive) ²	S+	S+
14	Sense line (negative) ²	S-	S-
16	Output voltage adjust ¹	R ¹	R ¹
18	Current sharing control	T	T
20	Do not connect (internal Gnd.)	-	-
22	Output good signal (positive)	Out OK +	Out OK +
24	Output good signal (negative)	Out OK -	Out OK -
26	Protective earth PE ²		
28	Inhibit control input ³	i	i
30	Input voltage (positive)	Vi+	Vi+
32	Input voltage (negative)	Vi-	Vi-

¹ Do not connect pin 16 for models with 3.3 V output or with opt. P !

² Leading pin (pre-connecting).

³ If not actively used, connect with pin 32.

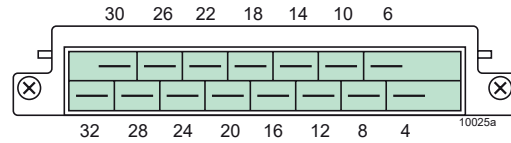



Fig. 26
View of male H15 connector

Installation Instructions

The Q Series converters are components, intended exclusively for inclusion within other equipment by an industrial assembly operation or by professional installers. Installation must strictly follow the national safety regulations in compliance to enclosure, mounting, creepage, clearance, casualty, markings and segregation requirements of the end-use application.

Connection to the system shall be made via the female connector H15 (see *Accessories*). Other installation methods may not meet the safety requirements.

The Q Series converters are provided with pin 26 () , which is reliably connected to the case. For safety reasons it is essential to connect this pin to protective earth; see *Safety of Operator-Accessible Output Circuits*.

The Vi- input (pin 32) is internally fused (except converters with option F). This fuse is designed to protect in case of overcurrent and may not be able to satisfy all customer requirements. External fuses in the wiring to one or both input pins (no. 30 and/or no. 32) may be necessary to ensure compliance with local requirements.

Important:

- If the inhibit function is not used, pin 28 (i) must be connected with pin 32 (Vi-) to enable the output(s).
- Do not open the converters, or warranty will be invalidated.
- Long input, output and auxiliary lines, or lines with inductors, filters or coupling/decoupling networks may cause instabilities. See *Input Stability with Long Supply Lines*.

Due to high output currents, the Q1001/1101 models offer two internally parallel-connected contacts for both, the positive and the negative output path (pins 4/6 and pins 8/10). It is recommended to connect the load to both female connector pins of each path in order to keep the voltage drop to a minimum.

Make sure that there is sufficient air flow available for convection cooling. This should be verified by measuring the case temperature when the converter is installed and operated in the end-user application. The maximum specified case temperature $T_{C,max}$ shall not be exceeded. See also *Thermal Considerations*.

Ensure that a converter failure (e.g. by an internal short-circuit) does not result in a hazardous condition. See also *Safety of Operator-Accessible Output Circuits*.

Cleaning Liquids and Protection Degree

In order to avoid possible damage, any penetration of cleaning fluids must be prevented, since the power supplies are not hermetically sealed.

Protection degree (female connector fitted to the converter):

- IP 30: All models, except those with option P (potentiometer)
- IP 20: All models with option P.

Standards and Approvals

The Q Series converters correspond to class I equipment. They are safety-approved to UL/CSA 60950-1 and IEC/EN 62368-1.

The converters have been evaluated for:

- Building in
- Basic insulation between input and case and double or reinforced insulation between input and output, based on their maximum rated input voltage
- Basic insulation between Out-OK and case, and double or reinforced insulation between Out-OK and input and between Out-OK and output, based on their maximum rated input voltage
- Functional insulation between outputs and output to case
- Use in a pollution degree 2 environment
- Connecting the input to a circuit, which is subject to a maximum transient rating of 1500 V.

CB Scheme is available.

The converters are subject to manufacturing surveillance in accordance with the above mentioned standards and with ISO 9001:2015.

Railway Applications

The converters have been designed observing the railway standards EN 50155:2017 and EN 50121-3-2:2016. All boards are coated with a protective lacquer.

The Q Series converters have been certified to the fire protection class HL1 to HL3 according to EN 45545.

Isolation

The electric strength test is performed in the factory as routine test according to EN 62911 and IEC/EN 62368-1. The company will not honor warranty claims resulting from incorrectly executed electric strength field tests. The resistance of the earth connection to the case (<0.1 Ω) is tested as well.

Table 18: Isolation

Characteristics		Input to Case + Output(s)	Output(s) to Case	Output to Output	Out-OK to Case + Input	Out-OK to Output(s)	Unit
Electric strength test	Factory test 10 s	2.1 ¹	2.1	0.5 [*]	2.1 ¹	2.1 ¹	kVDC
	AC test voltage equivalent to factory test	1.5 ¹	1.5	0.35 [*]	1.5 ¹	1.5 ¹	kVAC
Insulation resistance		>300 ²	>300 ²	>100	>300 ²	>300 ²	MΩ
Minimum creepage distances		1.4 ³	1.4				mm

* Models with version V104 or higher. Older converters have only been tested with 0.3 kVDC.

¹ Subassemblies connecting input to output are pre-tested with 3 kVAC or 4.2 kVDC.

² Tested at 500 VDC.

³ 2.8 mm between input and output.

Safety of Operator-Accessible Output Circuits

If the output circuit of a DC-DC converter is operator-accessible, it shall be an ES1 circuit according to IEC 62368-1.

Table 20 shows some possible installation configurations, compliance with which causes the output circuit of the DC-DC converter to be ES1 up to a configured output voltage (sum of nominal voltages, if in series configuration) of 35 V.

However, it is the sole responsibility of the installer to ensure the compliance with the relevant and applicable safety regulations.

Description of Options

Option P: Output Voltage Adjustment

Option P provides a built-in multi-turn potentiometer, which allows an output voltage adjustment of $\pm 10\%$ of $V_{o,nom}$. The potentiometer is accessible through a hole in the front cover.

With double-output models, both outputs are affected by the potentiometer. If converters are parallel-connected, their individual output voltage should be set within a tolerance of $\pm 1\%$.

If V_o is set higher than $V_{o,nom}$, the output currents should be reduced accordingly, so that the maximum specified output power is not exceeded.

Option -7: Temperature Range

Option -7 designates converters with an operational ambient temperature range of -25 to 71 °C. Not for new designs.

Option B, B1: Additional Heat Sink

Thickness: 12.5 mm (opt. B) or 20 mm (opt. B1)

Table 19: Thermal resistance case to ambient (approx. values)

Case	Thermal resistance	Thickness of case
Standard (160 mm long)	1.60 K/W	< 20 mm
Case 220 mm long ^{1,2}	1.40 K/W	< 20 mm
Option B	1.45 K/W	< 33 mm
Option B1	1.40 K/W	< 40 mm

¹ As well available with an additional heat sink

² Customer-specific models. Add 5000 to the part number!

Option F:

No internal fuse; the installer must use an appropriate external fuse or circuit breaker. CSA, NEMKO symbol on request.

Option non-G:

Leaded solder used (not RoHS-compliant).

Table 20: Safety concept leading to an ES1 output circuit

Conditions	Front end			DC-DC converter		Result
	Minimum required grade of insulation, to be provided by the AC-DC front end, including mains supplied battery charger	Maximum DC output voltage from the front end ¹	Minimum required safety status of the front end output circuit	Types	Measures required to achieve the specified safety status of the output circuit	
Mains ≤150 VAC	Functional (i.e. there is no need for electrical insulation between the mains supply circuit and the DC-DC converter input voltage)	≤ 150 V ²	Primary circuit	DQ EQ	Double or reinforced insulation, based on 150 VAC and DC (provided by the converter) and earthed case ³	ES1 circuit
	Basic	≤ 60 V	ELV circuit	BQ, GQ 48Q, CQ	Supplementary insulation, based on 150 VAC (provided by the DC-DC converter) and earthed case ³	
		≤ 75V	Hazardous voltage secondary circuit	48Q CQ	Supplementary insulation, based on 150 VAC and double or reinforced insulation ⁴ (both provided by the DC-DC converter) and earthed case ³	
Mains ≤ 250 VAC		≤ 60 V	Earthed ES1 circuit ³	BQ GQ 48Q CQ	Functional insulation (provided by the converter)	Earthed ES1 circuit
			ELV circuit		Input fuse ⁵ , output suppressor diodes ⁶ , earthed output circuit ³ and earthed ³ or non-user-accessible case	
		≤ 75V	Unearthed hazardous voltage secondary circuit	48Q CQ		
			Earthed hazardous voltage secondary circuit ³ or earthed ELV circuit	BQ, GQ 48Q, CQ DQ, EQ	Double or reinforced insulation ⁴ , (provided by the converter) and earthed case ³	ES1 circuit
			≤ 150 V	Unearthed hazardous voltage secondary circuit	DQ EQ	
				Double or reinforced	≤ 60 V	ES1 circuit
			≤ 120 V	TNV-3 circuit	48Q, CQ	Basic insulation ⁴ (provided by the DC-DC converter)
≤ 150 V			Double or reinforced insulated unearthed hazardous voltage secondary circuit ²	DQ, EQ		

¹ The front end output voltage should match the specified input voltage range of the DC-DC converter.
² Has to be insulated from earth according to IEC/EN 62368-1, by at least supplementary insulation, based on the maximum nominal output voltage from the front end.
³ The earth connection has to be provided by the installer according to IEC/EN 62368-1.
⁴ Based on the maximum rated output voltage provided by the front end.
⁵ The installer shall provide an approved fuse with the lowest rating suitable for the application in a non-earthed input conductor directly at the input of the DC-DC converter (see fig. *Schematic safety concept*). For UL's purposes, the fuse needs to be UL-listed.
⁶ Each suppressor diode should be dimensioned such that in the case of an insulation fault the diode is able to limit the output voltage to ES1 (<60 V), until the input fuse blows (see fig. *Schematic safety concept*).

Accessories

A variety of electrical and mechanical accessories are available:

- Various mating connectors including fast-on, screw, solder, or press-fit terminals, code key system; see Mating Connectors data sheet BCD.20022.
- Connector retention brackets (HZZ01217-G) CRB-Q
- Cable connector housings (cable hoods) HZZ00141-G, also available with fixation HZZ00142-G, and metallic cable hood HZZ00143-G.
- Front panels, system Schroff, for 19" racks in 3 U configuration 4 TE (G04-Q01), 5 TE (G05-Q01), or 6 TE (G06-Q01). Similar panels system Intermas available.
- Front panels, system Schroff, for 19" racks in 6 U configuration 5 TE (G05-6HE-Q01)
- Mechanical mounting supports for chassis, DIN-rail, and PCB mounting plate Q (HZZ01215-G) with retention clips Q (HZZ01229-G)
- Brackets for DIN-rail mounting UMB-LHMQ (HZZ00610-G)
- Additional external input and output filters
- Battery sensor [S-KSMH...] for using the converter as battery charger. Different cell characteristics can be selected.

For additional accessory product information, see the accessory data sheets listed with each product series or individual model at our website.

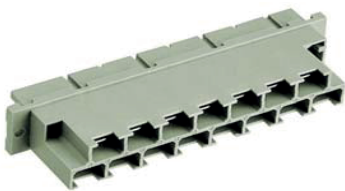

H15 female connector, code key system, faston, screw or other terminals

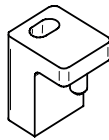

Connector retention bracket (HZZ01217-G)

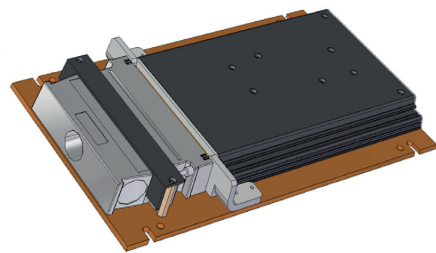

Mounting plate with fitted metallic cable hood with fastening screws (HZZ00143-G)



Mounting plate Q (HZZ01215-G) for wall mounting with fitted connector retention clips Q (HZZ01229-G)



Universal mounting bracket for DIN-rail and chassis mounting (HZZ00610-G).



Front panel kit G05-6HE-Q01 (HZZ00838) accommodating two units for a 19" DIN-rack with 6 U, 5 TE.

NUCLEAR AND MEDICAL APPLICATIONS - These products are not designed or intended for use as critical components in life support systems, equipment used in hazardous environments, or nuclear control systems.

TECHNICAL REVISIONS - The appearance of products, including safety agency certifications pictured on labels, may change depending on the date manufactured. Specifications are subject to change without notice.

Looking for pricing, stock, or lifecycle information?

Click below to explore more details on WIN SOURCE:

- [View BQ1001-9R on WIN SOURCE](#)
- [Bel Power Solutions Information](#)

Optimize Your Supply Chain with WIN SOURCE Solutions

- ✓ Global Sourcing Solution
- ✓ Obsolete Management
- ✓ Cost Control Management
- ✓ Shortage Management
- ✓ Alternative Solution
- ✓ Excess Inventory Management