



**THE DATASHEET OF  
BGU7051,118**



# BGU7051

## SiGe:C low noise high linearity amplifier

Rev. 2 — 11 November 2011

Product data sheet

## 1. Product profile

### 1.1 General description

The BGU7051 is a low noise high linearity amplifier for wireless infrastructure applications. The LNA has a high input and output return loss and is designed to operate between 0.5 GHz and 1.5 GHz. It is housed in a  $3 \times 3 \times 0.85 \text{ mm}^3$  10-terminal plastic thin small outline package. The LNA is ESD protected on all terminals.

### 1.2 Features and benefits

- Low Noise Figure (NF) = 0.65 dB at 900 MHz
- High linearity performance,  $IP3O = 33 \text{ dBm}$  at 900 MHz
- High input and output return loss
- Unconditionally stable
- 110 GHz transit frequency - SiGe:C technology
- Supply voltage 3.3 V
- Small 10-terminal leadless package  $3 \times 3 \times 0.85 \text{ mm}^3$
- ESD protection on all terminals
- Moisture sensitivity level 1

### 1.3 Applications

- LNA for wireless infrastructure applications (0.5 GHz to 1.5 GHz)
- Low noise applications

### 1.4 Quick reference data

**Table 1. Quick reference data**

*f = 900 MHz; V<sub>CC</sub> = 3.3 V; T<sub>amb</sub> = 25 °C; input and output 50 Ω; unless otherwise specified.*

Symbol	Parameter	Conditions	Min	Typ	Max	Unit
V <sub>CC</sub>	supply voltage		3.0	-	3.6	V
I <sub>CC</sub>	supply current		50	65	80	mA
G <sub>ass</sub>	associated gain		19.5	21.0	22.5	dB
NF	noise figure		-	0.65	0.95	dB
P <sub>L(1dB)</sub>	output power at 1 dB gain compression		15	16.5	-	dBm
IP <sub>3O</sub>	output third-order intercept point		30	33	-	dBm



## 2. Pinning information

### 2.1 Pinning

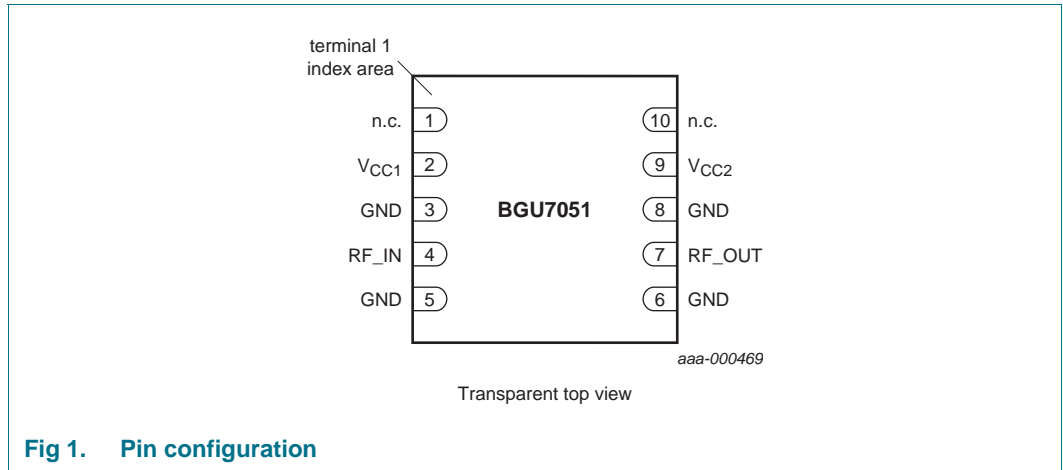

Fig 1. Pin configuration

### 2.2 Pin description

Table 2. Pin description

Symbol	Pin	Description
n.c.	1, 10	not connected
V <sub>CC1</sub>	2	supply voltage
GND	3, 5, 6, 8	ground
RF_IN	4	RF input
RF_OUT	7	RF output
V <sub>CC2</sub>	9	supply voltage

## 3. Ordering information

Table 3. Ordering information

Type number	Package		
	Name	Description	Version
BGU7051	HVSON10	plastic thermal enhanced very thin small outline package; no leads; 10 terminals; body 3 × 3 × 0.85 mm	SOT650-1

## 4. Limiting values

**Table 4. Limiting values**

*In accordance with the Absolute Maximum Rating System (IEC 60134).*

Symbol	Parameter	Conditions	Min	Max	Unit
$V_{CC}$	supply voltage		0	5	V
$P_{i(RF)CW}$	continuous waveform RF input power	$V_{CC} = 3.3$ V	-	20	dBm
$T_{stg}$	storage temperature		-65	150	°C
$T_j$	junction temperature		-	150	°C
$T_{amb}$	ambient temperature		-40	85	°C
$V_{ESD}$	electrostatic discharge voltage	Human Body Model (HBM); According JEDEC standard 22-A114E	-	4	kV
		Charged Device Model (CDM); According JEDEC standard 22-C101B	-	2	kV

## 5. Thermal characteristics

**Table 5. Thermal characteristics**

Symbol	Parameter	Conditions	Typ	Unit
$R_{th(j-sp)}$	thermal resistance from junction to solder point		26	K/W

## 6. Characteristics

**Table 6. Characteristics**

$V_{CC} = 3.3$  V;  $T_{amb} = 25$  °C; input and output 50  $\Omega$ ; unless otherwise specified. All RF parameters are measured at the device RF in and RF output terminals.

Symbol	Parameter	Conditions	Min	Typ	Max	Unit
$V_{CC}$	supply voltage		3.0	-	3.6	V
$I_{CC}$	supply current		50	65	80	mA
$G_{ass}$	associated gain	f = 750 MHz	-	23.5	-	dB
		f = 850 MHz	-	21.5	-	dB
		f = 900 MHz	19.5	21.0	22.5	dB
NF	noise figure	f = 750 MHz	-	0.6	-	dB
		f = 850 MHz	-	0.63	-	dB
		f = 900 MHz	-	0.65	0.95	dB
$P_{L(1dB)}$	output power at 1 dB gain compression	f = 750 MHz	-	17.0	-	dBm
		f = 850 MHz	-	16.5	-	dBm
		f = 900 MHz	15	16.5	-	dBm
IP3 <sub>O</sub>	output third-order intercept point	2-tone; spacing 5 MHz; $P_i = -20$ dBm				
		f = 750 MHz	-	32	-	dBm
		f = 850 MHz	-	32	-	dBm
		f = 900 MHz	30	33	-	dBm

**Table 6. Characteristics ...continued**

$V_{CC} = 3.3\text{ V}$ ;  $T_{amb} = 25\text{ }^{\circ}\text{C}$ ; input and output  $50\ \Omega$ ; unless otherwise specified. All RF parameters are measured at the device RF in and RF output terminals.

Symbol	Parameter	Conditions	Min	Typ	Max	Unit
RL <sub>in</sub>	input return loss	f = 750 MHz	-	27.5	-	dB
		f = 850 MHz	-	26.0	-	dB
		f = 900 MHz	-	24.5	-	dB
RL <sub>out</sub>	output return loss	f = 750 MHz	-	18.0	-	dB
		f = 850 MHz	-	17.5	-	dB
		f = 900 MHz	-	18	-	dB
ISL	isolation	f = 750 MHz	-	29.5	-	dB
		f = 850 MHz	-	27.5	-	dB
		f = 900 MHz	-	26.5	-	dB
K	Rollett stability factor	0 GHz ≤ f ≤ 25 GHz	1	-	-	

**6.1 Performance curves**

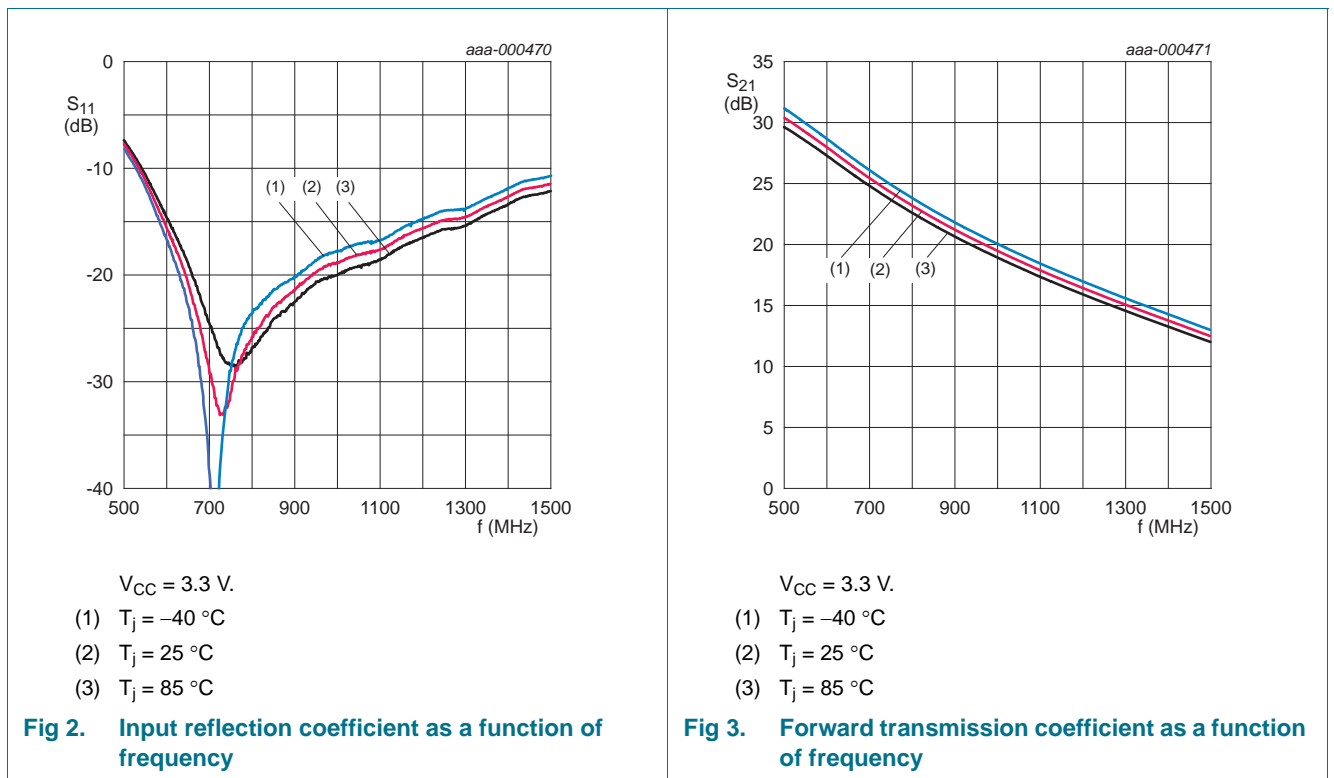

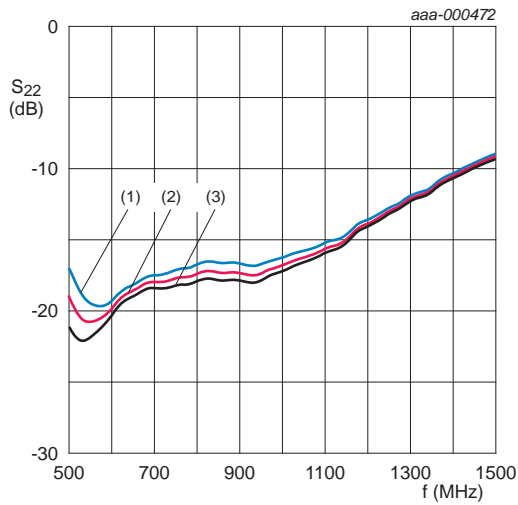

$V_{CC} = 3.3 \text{ V}$ .  
 (1)  $T_j = -40 \text{ }^\circ\text{C}$   
 (2)  $T_j = 25 \text{ }^\circ\text{C}$   
 (3)  $T_j = 85 \text{ }^\circ\text{C}$

**Fig 4. Output reflection coefficient as a function of frequency**

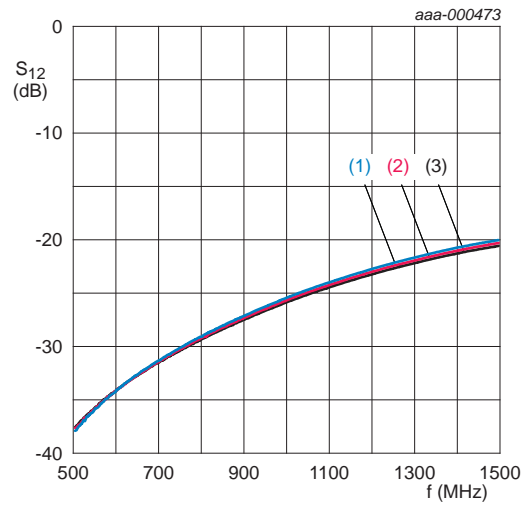

$V_{CC} = 3.3 \text{ V}$ .  
 (1)  $T_j = -40 \text{ }^\circ\text{C}$   
 (2)  $T_j = 25 \text{ }^\circ\text{C}$   
 (3)  $T_j = 85 \text{ }^\circ\text{C}$

**Fig 5. Reverse transmission coefficient as a function of frequency**

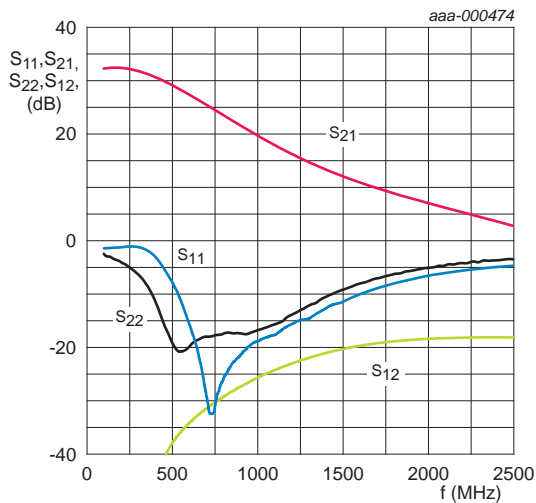

$V_{CC} = 3.3 \text{ V}$ ;  $T_{amb} = 25 \text{ }^\circ\text{C}$ .

**Fig 6. Wideband s-parameters as a function of frequency**

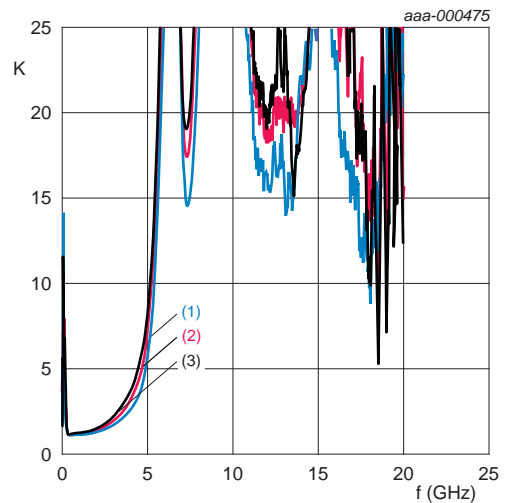

$V_{CC} = 3.3 \text{ V}$ .  
 (1)  $T_j = -40 \text{ }^\circ\text{C}$   
 (2)  $T_j = 25 \text{ }^\circ\text{C}$   
 (3)  $T_j = 85 \text{ }^\circ\text{C}$

**Fig 7. Stability K-factor as a function of frequency**

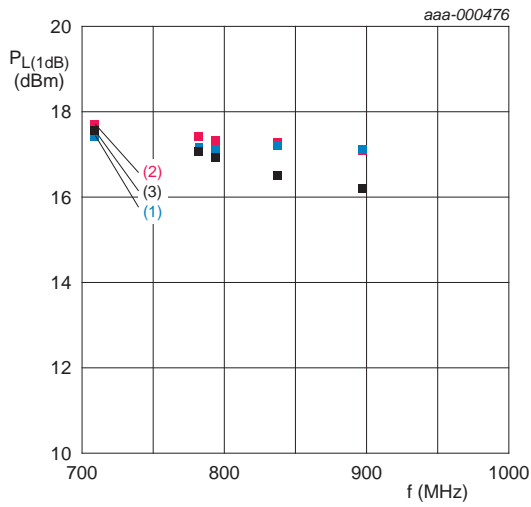

$V_{CC} = 3.3\text{ V}$ .  
 (1)  $T_j = -40^\circ\text{C}$   
 (2)  $T_j = 25^\circ\text{C}$   
 (3)  $T_j = 85^\circ\text{C}$

**Fig. 8. Output power at 1 dB gain compression as a function of frequency**

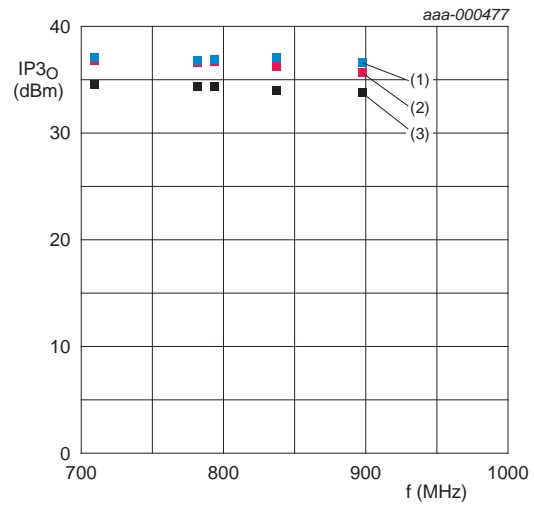

$V_{CC} = 3.3\text{ V}$ .  
 (1)  $T_j = -40^\circ\text{C}$   
 (2)  $T_j = 25^\circ\text{C}$   
 (3)  $T_j = 85^\circ\text{C}$

**Fig. 9. Output third-order intercept point as a function of frequency**

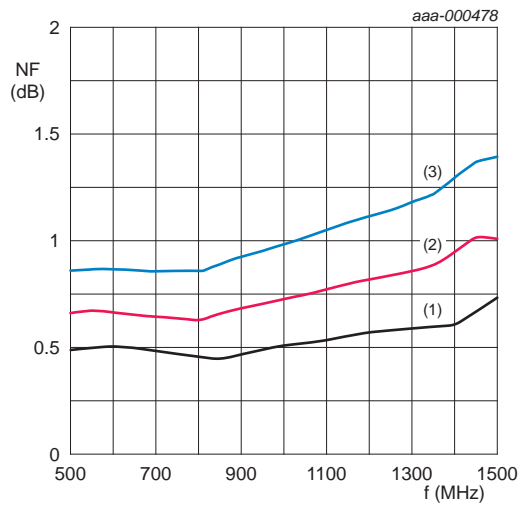

$V_{CC} = 3.3\text{ V}$ .  
 (1)  $T_j = -40^\circ\text{C}$   
 (2)  $T_j = 25^\circ\text{C}$   
 (3)  $T_j = 85^\circ\text{C}$

**Fig. 10. Noise figure as function of frequency**

## 7. Application information

[Figure 11](#) shows the typical application circuit for the BGU7051. The device is internally matched to 50 Ω, and therefore does not need any external matching. The value of the input and output DC blocking C1 and C2 are recommended to be 1 nF. DC decoupling capacitors C3 and C4 should be located as close as possible to the BGU7051.

In case different system blocks are supplied via the same voltage rail, it is recommended to use a bias choke in the bias line on the positions of R1 and R2. The value of this choke is depending on the frequency that needs to be decoupled.

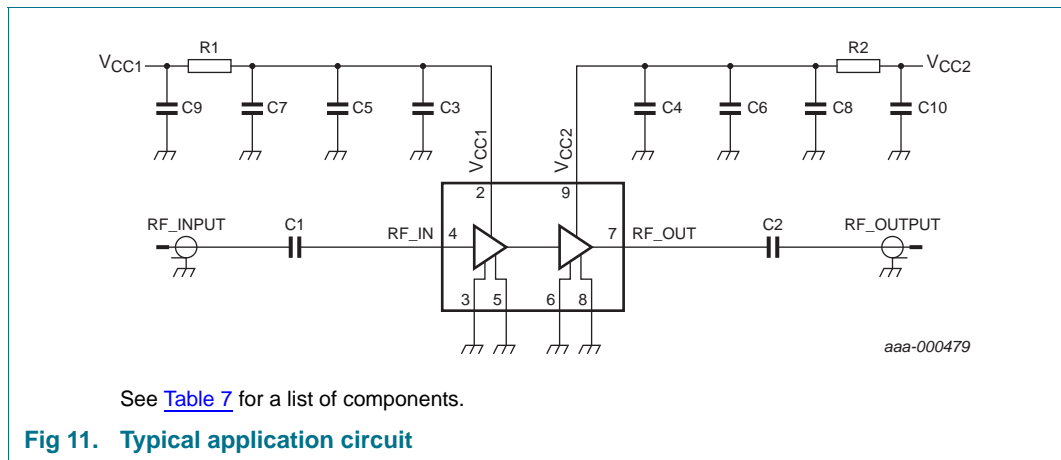

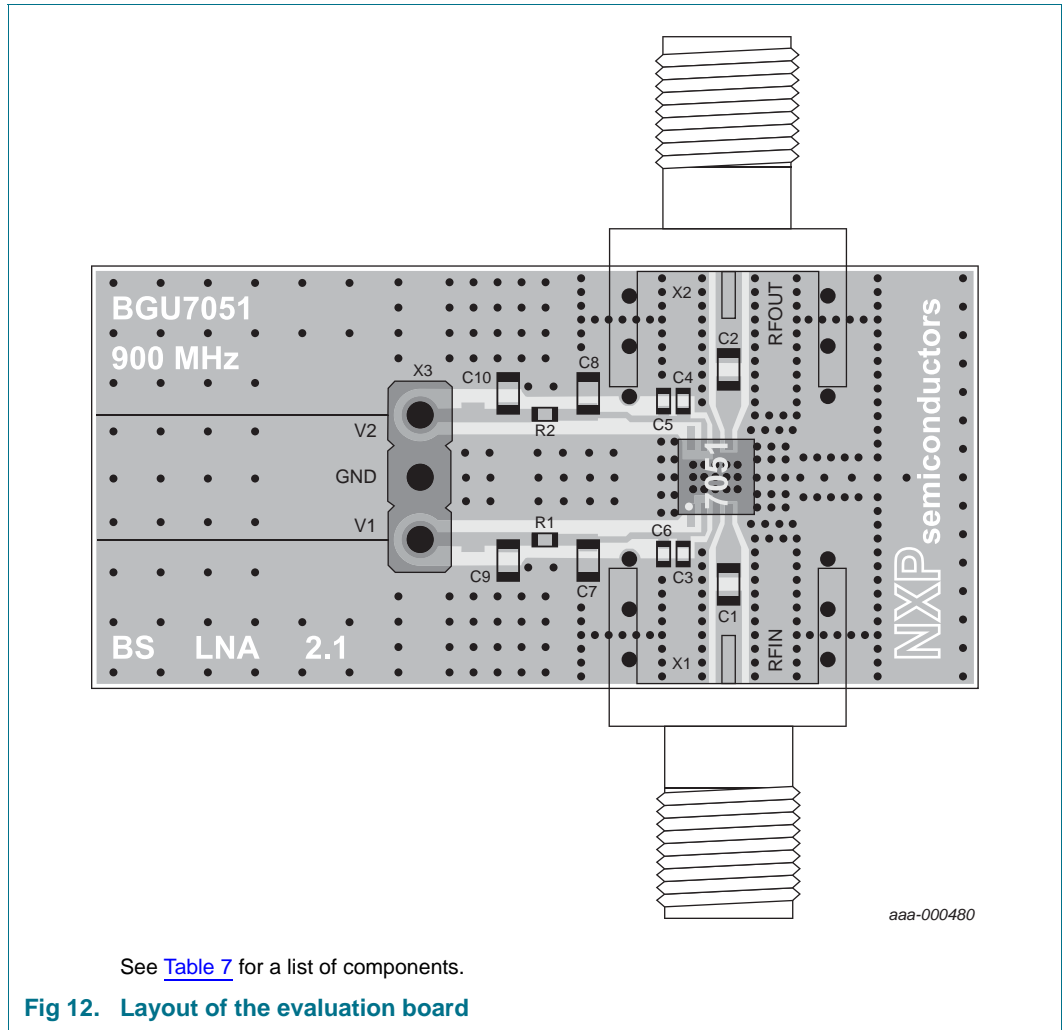

**Table 7. List of components**

See [Figure 11](#) for schematics.

Component	Description	Value	Size	Function
C1, C2	capacitor	[1] 1 nF	0402	DC block
C3, C4	capacitor	[1] 100 pF	0402	bias decoupling
C5, C6	capacitor	[1] 100 nF	0402	bias decoupling
C7, C8, C9, C10	capacitor	[2] 100 nF	0603	optional
R1, R2	resistor	0 Ω	0402	

[1] Murata GRM155 or capacitor of same quality.

[2] Murata GRM188 or capacitor of same quality.

## 8. Package outline

HVSON10: plastic thermal enhanced very thin small outline package; no leads;  
10 terminals; body 3 x 3 x 0.85 mm

SOT650-1

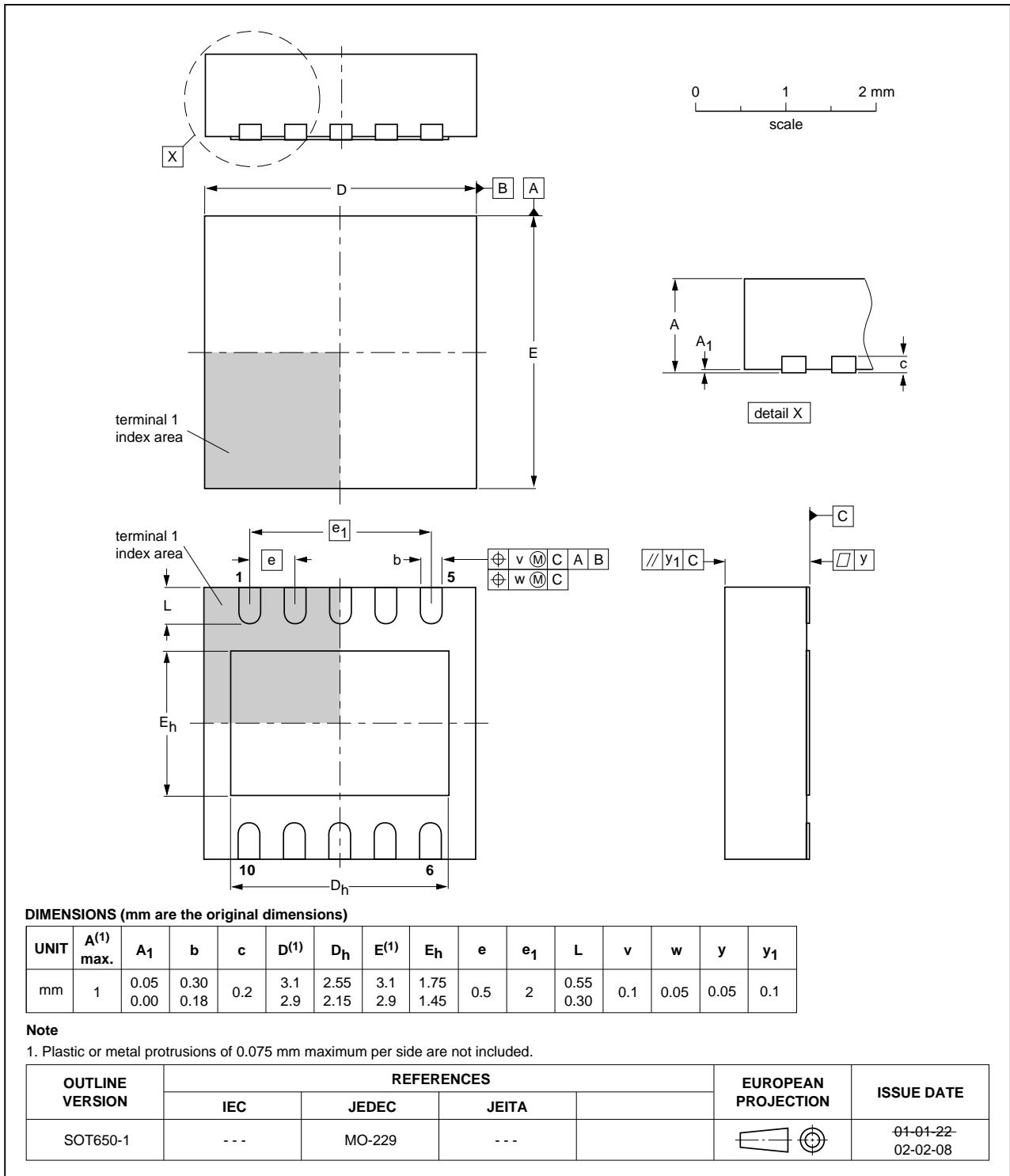

Fig 13. Package outline SOT650-1 (HVSON10)

## 9. Abbreviations

**Table 8. Abbreviations**

Acronym	Description
AC	Alternating Current
CW	Continuous Wave
ESD	ElectroStatic Discharge
ESR	Equivalent Series Resistance
HBM	Human Body Model
LNA	Low Noise Amplifier
PDA	Personal Digital Assistant
RF	Radio Frequency
SiGe:C	Silicon Germanium Carbon

## 10. Revision history

**Table 9. Revision history**

Document ID	Release date	Data sheet status	Change notice	Supersedes
BGU7051 v.2	20111111	Product data sheet	-	BGU7051 v.1
Modifications:	<ul style="list-style-type: none"> <li>• <a href="#">Figure 10</a>: data plots updated</li> <li>• Unit dB changed to dBm for <math>P_{L(1dB)}</math> in <a href="#">Section 6 "Characteristics"</a></li> </ul>			
BGU7051 v.1	20111027	Product data sheet	-	-

## 11. Legal information

### 11.1 Data sheet status

Document status <sup>[1][2]</sup>	Product status <sup>[3]</sup>	Definition
Objective [short] data sheet	Development	This document contains data from the objective specification for product development.
Preliminary [short] data sheet	Qualification	This document contains data from the preliminary specification.
Product [short] data sheet	Production	This document contains the product specification.

[1] Please consult the most recently issued document before initiating or completing a design.

[2] The term 'short data sheet' is explained in section "Definitions".

[3] The product status of device(s) described in this document may have changed since this document was published and may differ in case of multiple devices. The latest product status information is available on the Internet at URL <http://www.nxp.com>.

### 11.2 Definitions

**Draft** — The document is a draft version only. The content is still under internal review and subject to formal approval, which may result in modifications or additions. NXP Semiconductors does not give any representations or warranties as to the accuracy or completeness of information included herein and shall have no liability for the consequences of use of such information.

**Short data sheet** — A short data sheet is an extract from a full data sheet with the same product type number(s) and title. A short data sheet is intended for quick reference only and should not be relied upon to contain detailed and full information. For detailed and full information see the relevant full data sheet, which is available on request via the local NXP Semiconductors sales office. In case of any inconsistency or conflict with the short data sheet, the full data sheet shall prevail.

**Product specification** — The information and data provided in a Product data sheet shall define the specification of the product as agreed between NXP Semiconductors and its customer, unless NXP Semiconductors and customer have explicitly agreed otherwise in writing. In no event however, shall an agreement be valid in which the NXP Semiconductors product is deemed to offer functions and qualities beyond those described in the Product data sheet.

### 11.3 Disclaimers

**Limited warranty and liability** — Information in this document is believed to be accurate and reliable. However, NXP Semiconductors does not give any representations or warranties, expressed or implied, as to the accuracy or completeness of such information and shall have no liability for the consequences of use of such information.

In no event shall NXP Semiconductors be liable for any indirect, incidental, punitive, special or consequential damages (including - without limitation - lost profits, lost savings, business interruption, costs related to the removal or replacement of any products or rework charges) whether or not such damages are based on tort (including negligence), warranty, breach of contract or any other legal theory.

Notwithstanding any damages that customer might incur for any reason whatsoever, NXP Semiconductors' aggregate and cumulative liability towards customer for the products described herein shall be limited in accordance with the *Terms and conditions of commercial sale* of NXP Semiconductors.

**Right to make changes** — NXP Semiconductors reserves the right to make changes to information published in this document, including without limitation specifications and product descriptions, at any time and without notice. This document supersedes and replaces all information supplied prior to the publication hereof.

**Suitability for use** — NXP Semiconductors products are not designed, authorized or warranted to be suitable for use in life support, life-critical or safety-critical systems or equipment, nor in applications where failure or

malfunction of an NXP Semiconductors product can reasonably be expected to result in personal injury, death or severe property or environmental damage. NXP Semiconductors accepts no liability for inclusion and/or use of NXP Semiconductors products in such equipment or applications and therefore such inclusion and/or use is at the customer's own risk.

**Applications** — Applications that are described herein for any of these products are for illustrative purposes only. NXP Semiconductors makes no representation or warranty that such applications will be suitable for the specified use without further testing or modification.

Customers are responsible for the design and operation of their applications and products using NXP Semiconductors products, and NXP Semiconductors accepts no liability for any assistance with applications or customer product design. It is customer's sole responsibility to determine whether the NXP Semiconductors product is suitable and fit for the customer's applications and products planned, as well as for the planned application and use of customer's third party customer(s). Customers should provide appropriate design and operating safeguards to minimize the risks associated with their applications and products.

NXP Semiconductors does not accept any liability related to any default, damage, costs or problem which is based on any weakness or default in the customer's applications or products, or the application or use by customer's third party customer(s). Customer is responsible for doing all necessary testing for the customer's applications and products using NXP Semiconductors products in order to avoid a default of the applications and the products or of the application or use by customer's third party customer(s). NXP does not accept any liability in this respect.

**Limiting values** — Stress above one or more limiting values (as defined in the Absolute Maximum Ratings System of IEC 60134) will cause permanent damage to the device. Limiting values are stress ratings only and (proper) operation of the device at these or any other conditions above those given in the Recommended operating conditions section (if present) or the Characteristics sections of this document is not warranted. Constant or repeated exposure to limiting values will permanently and irreversibly affect the quality and reliability of the device.

**Terms and conditions of commercial sale** — NXP Semiconductors products are sold subject to the general terms and conditions of commercial sale, as published at <http://www.nxp.com/profile/terms>, unless otherwise agreed in a valid written individual agreement. In case an individual agreement is concluded only the terms and conditions of the respective agreement shall apply. NXP Semiconductors hereby expressly objects to applying the customer's general terms and conditions with regard to the purchase of NXP Semiconductors products by customer.

**No offer to sell or license** — Nothing in this document may be interpreted or construed as an offer to sell products that is open for acceptance or the grant, conveyance or implication of any license under any copyrights, patents or other industrial or intellectual property rights.

**Export control** — This document as well as the item(s) described herein may be subject to export control regulations. Export might require a prior authorization from competent authorities.

**Non-automotive qualified products** — Unless this data sheet expressly states that this specific NXP Semiconductors product is automotive qualified, the product is not suitable for automotive use. It is neither qualified nor tested in accordance with automotive testing or application requirements. NXP Semiconductors accepts no liability for inclusion and/or use of non-automotive qualified products in automotive equipment or applications.

In the event that customer uses the product for design-in and use in automotive applications to automotive specifications and standards, customer (a) shall use the product without NXP Semiconductors' warranty of the product for such automotive applications, use and specifications, and (b) whenever customer uses the product for automotive applications beyond NXP Semiconductors' specifications such use shall be solely at customer's own risk, and (c) customer fully indemnifies NXP Semiconductors for any

liability, damages or failed product claims resulting from customer design and use of the product for automotive applications beyond NXP Semiconductors' standard warranty and NXP Semiconductors' product specifications.

**Quick reference data** — The Quick reference data is an extract of the product data given in the Limiting values and Characteristics sections of this document, and as such is not complete, exhaustive or legally binding.

## 11.4 Trademarks

Notice: All referenced brands, product names, service names and trademarks are the property of their respective owners.

## 12. Contact information

For more information, please visit: <http://www.nxp.com>

For sales office addresses, please send an email to: [salesaddresses@nxp.com](mailto:salesaddresses@nxp.com)

## 13. Contents

<b>1</b>	<b>Product profile</b> . . . . .	<b>1</b>
1.1	General description . . . . .	1
1.2	Features and benefits . . . . .	1
1.3	Applications . . . . .	1
1.4	Quick reference data . . . . .	1
<b>2</b>	<b>Pinning information</b> . . . . .	<b>2</b>
2.1	Pinning . . . . .	2
2.2	Pin description . . . . .	2
<b>3</b>	<b>Ordering information</b> . . . . .	<b>2</b>
<b>4</b>	<b>Limiting values</b> . . . . .	<b>3</b>
<b>5</b>	<b>Thermal characteristics</b> . . . . .	<b>3</b>
<b>6</b>	<b>Characteristics</b> . . . . .	<b>3</b>
6.1	Performance curves . . . . .	4
<b>7</b>	<b>Application information</b> . . . . .	<b>7</b>
<b>8</b>	<b>Package outline</b> . . . . .	<b>9</b>
<b>9</b>	<b>Abbreviations</b> . . . . .	<b>10</b>
<b>10</b>	<b>Revision history</b> . . . . .	<b>10</b>
<b>11</b>	<b>Legal information</b> . . . . .	<b>11</b>
11.1	Data sheet status . . . . .	11
11.2	Definitions . . . . .	11
11.3	Disclaimers . . . . .	11
11.4	Trademarks . . . . .	12
<b>12</b>	<b>Contact information</b> . . . . .	<b>12</b>
<b>13</b>	<b>Contents</b> . . . . .	<b>13</b>

Please be aware that important notices concerning this document and the product(s) described herein, have been included in section 'Legal information'.

© NXP B.V. 2011.

All rights reserved.

For more information, please visit: <http://www.nxp.com>

For sales office addresses, please send an email to: [salesaddresses@nxp.com](mailto:salesaddresses@nxp.com)

Date of release: 11 November 2011

Document identifier: BGU7051

## Looking for pricing, stock, or lifecycle information?

Click below to explore more details on WIN SOURCE:

- [View BGU7051,118 on WIN SOURCE](#)
- [NXP / Nexperia Information](#)

## Optimize Your Supply Chain with WIN SOURCE Solutions

- ✓ Global Sourcing Solution
- ✓ Obsolete Management
- ✓ Cost Control Management
- ✓ Shortage Management
- ✓ Alternative Solution
- ✓ Excess Inventory Management