



**THE DATASHEET OF
BGS18GA14E6327XTSA1**



BGS18GA14

SP8T Diversity Antenna Switch with GPIO Interface

Data Sheet

Revision 3.0 - 2016-02-29

Edition 2016-02-29

**Published by Infineon Technologies AG
81726 Munich, Germany**

**©2016 Infineon Technologies AG
All Rights Reserved.**

LEGAL DISCLAIMER

The information given in this document shall in no event be regarded as a guarantee of conditions or characteristics. With respect to any examples or hints given herein, any typical values stated herein and/or any information regarding the application of the device, Infineon Technologies hereby disclaims any and all warranties and liabilities of any kind, including without limitation, warranties of non-infringement of intellectual property rights of any third party.

Information

For further information on technology, delivery terms and conditions and prices, please contact the nearest Infineon Technologies Office (www.infineon.com).

Warnings

Due to technical requirements, components may contain dangerous substances. For information on the types in question, please contact the nearest Infineon Technologies Office. Infineon Technologies components may be used in life-support devices or systems only with the express written approval of Infineon Technologies, if a failure of such components can reasonably be expected to cause the failure of that life-support device or system or to affect the safety or effectiveness of that device or system. Life support devices or systems are intended to be implanted in the human body or to support and/or maintain and sustain and/or protect human life. If they fail, it is reasonable to assume that the health of the user or other persons may be endangered.

Revision History

Document No.: BGS18GA14__v3.0.pdf

Revision History: Rev. v3.0

Previous Version: 2.0

Page	Subjects (major changes since last revision)
12	Carrier tape drawing updated

Trademarks of Infineon Technologies AG

μ HVICTM, μ IPMTM, μ PFCTM, AU-ConvertIRTM, AURIXTM, C166TM, CanPAKTM, CIPOSTM, CIPURSETM, CoolDPTM, CoolGaNTM, COOLiRTM, CoolMOSTM, CoolSETTM, CoolSiCTM, DAVETM, DI-POLTM, DirectFETTM, DrBladeTM, EasyPIMTM, EconoBRIDGETM, EconoDUALTM, EconoPACKTM, EconoPIMTM, EiceDRIVERTM, eupecTM, FCOSTM, GaNpowIRTM, HEXFETTM, HITFETTM, HybridPACKTM, iMOTIONTM, IRAMTM, ISOFACETM, IsoPACKTM, LEDrivIRTM, LITIXTM, MIPAQTM, ModSTACKTM, my-dTM, NovalithICTM, OPTIGATM, OptiMOSTM, ORIGATM, PowIRaudioTM, PowIRStageTM, PrimePACKTM, PrimeSTACKTM, PROFETTM, PRO-SILTM, RASICTM, REAL3TM, SmartLEWISTM, SOLID FLASHTM, SPOCTM, StrongIRFETTM, SupIRBuckTM, TEMPFETTM, TRENCHSTOPTM, TriCoreTM, UHVICTM, XHPTM, XMCTM.

Other Trademarks

All referenced product or service names and trademarks are the property of their respective owners.

Trademarks updated November 2015

Contents

1	Features	5
2	Product Description	5
3	Maximum Ratings	6
4	Operation Ranges	7
5	RF Characteristics	8
6	GPIO Specification	9
7	Package related information	9

List of Figures

1	BGS18GA14 block diagram	6
2	Footprint, top view	10
3	Package Outline Drawing	11
4	Land Pattern Drawing	11
5	Laser marking	12
6	Carrier Tape	12

List of Tables

1	Ordering Information	5
2	Maximum Ratings, Table I	6
3	Maximum Ratings, Table II	7
4	Operation Ranges	7
5	RF Input Power	7
6	RF Characteristics	8
7	IMD2 Testcases	9
8	IMD3 Testcases	9
9	GPIO Truth Table	9
10	Mechanical Data	9
11	Pin definition	10

BGS18GA14

1 Features

- 8 high-linearity, interchangeable RX ports
- Low insertion loss
- Low harmonic generation
- High port-to-port-isolation
- Suitable for Edge / C2K / LTE / WCDMA Applications
- 0.1 to 3.8 GHz coverage
- No decoupling capacitors required if no DC applied on RF lines
- On chip control logic including ESD protection
- General Purpose Input-Output (GPIO) Interface
- Small form factor 2.0 mm x 2.0 mm
- No power supply blocking required
- High EMI robustness
- RoHS and WEEE compliant package

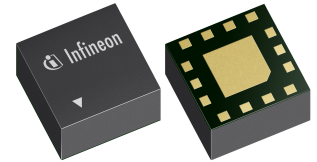

2 Product Description

The BGS18GA14 is a Single Pole Eight Throw (SP8T) Diversity Switch Module optimized for wireless applications up to 3.8 GHz. As part of a pin- and functional-compatible SP3T-SP8T product family it has been designed to meet the requirements of chipset reference designs. The module comes in a miniature ATSLP package and comprises of a high power CMOS SP8T switch with integrated GPIO interface. This RF switch is a perfect solution for multimode handsets based on LTE and WCDMA. The switch device configuration is shown in Fig. 1.

The switch is controlled via a GPIO interface. It features DC-free RF ports and unlike GaAs technology, external DC blocking capacitors at the RF ports are only required if DC voltage is applied externally.

Table 1: Ordering Information

Type	Package	Marking
BGS18GA14	ATSLP-14	G8

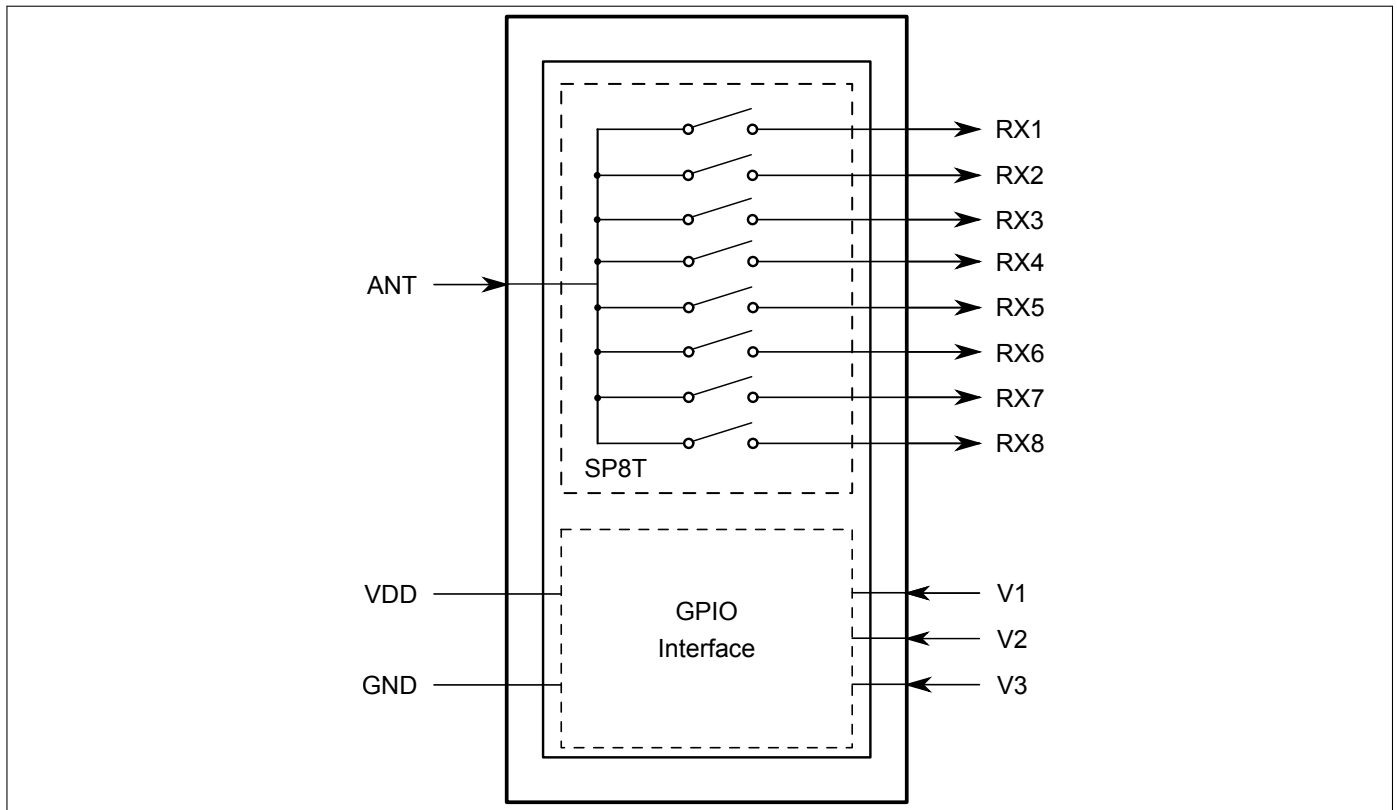
Figure 1: BGS18GA14 block diagram

3 Maximum Ratings

Table 2: Maximum Ratings, Table I at $T_A = 25\text{ }^\circ\text{C}$, unless otherwise specified

Parameter	Symbol	Values			Unit	Note / Test Condition
		Min.	Typ.	Max.		
Frequency Range	f	0.1	–	–	GHz	¹⁾
Supply voltage	V_{dd}	-0.5	–	3.6	V	–
Storage temperature range	T_{STG}	-55	–	150	$^\circ\text{C}$	–
Junction temperature	T_j	–	–	125	$^\circ\text{C}$	–
RF input power at all Rx ports	P_{RF_Rx}	–	–	32	dBm	CW
ESD capability, CDM ²⁾	V_{ESDCDM}	-500	–	+500	V	All pins
ESD capability, HBM ³⁾	V_{ESDHBM}	-1	–	+1	kV	Digital, digital versus RF
		-1	–	+1	V	RF
ESD capability, system level ⁴⁾	V_{ESDANT}	-8	–	+8	kV	ANT versus system GND, with 27 nH shunt inductor

¹⁾ There is also a DC connection between switched paths. The DC voltage at RF ports V_{RFDC} has to be 0V.

²⁾ Field-Induced Charged-Device Model JESD22-C101. Simulates charging/discharging events that occur in production equipment and processes. Potential for CDM ESD events occurs whenever there is metal-to-metal contact in manufacturing.

³⁾ Human Body Model ANSI/ESDA/JEDEC JS-001-2012 ($R = 1.5\text{ k}\Omega$, $C = 100\text{ pF}$).

⁴⁾ IEC 61000-4-2 ($R = 330\text{ }\Omega$, $C = 150\text{ pF}$), contact discharge.

Table 3: Maximum Ratings, Table II at $T_A = 25\text{ }^\circ\text{C}$, unless otherwise specified

Parameter	Symbol	Values			Unit	Note / Test Condition
		Min.	Typ.	Max.		
Thermal resistance junction - soldering point	R_{thJS}	–	60	–	K/W	–
Maximum DC-voltage on RF-Ports and RF-Ground	V_{RFDC}	0	–	0	V	No DC voltages allowed on RF-Ports
GPIO control voltage levels	V_{Ctrlx}	-0.7	–	$V_{dd}+0.7$	V	–

4 Operation Ranges

Table 4: Operation Ranges

Parameter	Symbol	Values			Unit	Note / Test Condition
		Min.	Typ.	Max.		
Supply voltage	V_{dd}	2.4	3.0	3.4	V	–
Supply current	I_{dd}	–	75	175	μA	–
GPIO control voltage high	V_{Ctrl_H}	1.35	–	V_{dd}	V	–
GPIO control voltage low	V_{Ctrl_L}	0	–	0.45	V	–
GPIO control input capacitance	C_{Ctrl}	–	–	2	pF	–
Ambient temperature	T_A	-30	25	85	$^\circ\text{C}$	–

Table 5: RF Input Power

Parameter	Symbol	Values			Unit	Note / Test Condition
		Min.	Typ.	Max.		
Rx ports (50 Ω)	P_{RF_Rx}	–	–	28	dBm	–

5 RF Characteristics

Table 6: RF Characteristics at $T_A = -30\text{ }^{\circ}\text{C} \dots 85\text{ }^{\circ}\text{C}$, $P_{IN} = 0\text{ dBm}$, Supply Voltage $V_{dd} = 2.4\text{ V} \dots 3.4\text{ V}$, unless otherwise specified

Parameter	Symbol	Values			Unit	Note / Test Condition
		Min.	Typ.	Max.		
Insertion Loss¹⁾						
All Rx Ports	IL	–	0.27	0.35	dB	698–960 MHz
		–	0.42	0.56	dB	1428–1990 MHz
		–	0.48	0.58	dB	1920–2170 MHz
		–	0.56	0.62	dB	2170–2690 MHz
		–	0.69	0.75	dB	3400–3600 MHz
		–	0.74	0.80	dB	3600–3800 MHz
Return Loss¹⁾						
All Rx Ports	RL	20	24	–	dB	698–960 MHz
		14	19	–	dB	1428–1990 MHz
		13	17	–	dB	1920–2170 MHz
		12	15	–	dB	2170–2690 MHz
		11	12	–	dB	3400–3600 MHz
		10	11	–	dB	3600–3800 MHz
Isolation¹⁾						
All Rx Ports	ISO	32	50	–	dB	698–960 MHz
		26	41	–	dB	1428–1990 MHz
		24	39	–	dB	1920–2170 MHz
		22	37	–	dB	2170–2690 MHz
		19	33	–	dB	3400–3600 MHz
		19	32	–	dB	3600–3800 MHz
Harmonic Generation (UMTS Band 1, Band 5)¹⁾						
2 nd harmonic generation	P_{H2}	92	105	–	dBc	25 dBm, 50 Ω , CW mode
3 rd harmonic generation	P_{H3}	88	96	–	dBc	25 dBm, 50 Ω , CW mode
Intermodulation Distortion (UMTS Band 1, Band 5)¹⁾						
2 nd order intermodulation	IMD2 low	–	-105	-100	dBm	IMT, US Cell (see Tab. 7)
3 rd order intermodulation	IMD3	–	-110	-105	dBm	IMT, US Cell (see Tab. 8)
2 nd order intermodulation	IMD2 high	–	-115	-110	dBm	IMT, US Cell (see Tab. 7)
Switching Time						
RF Rise Time	t_{RT}	–	–	2	μs	10 % to 90 % RF signal
Switching Time	t_{ST}	–	2	4	μs	50 % Ctrl signal to 90 % RF signal
Power Up Settling Time	t_{PUp}	–	10	25	μs	After power down mode

¹⁾On application board without any matching components.

Table 7: IMD2 Testcases

Band	CW tone 1 (MHz)	CW tone 1 (dBm)	CW tone 2 (MHz)	CW tone 2 (dBm)
IMT	1950	20	190 (IMD2 low)	-15
			4090 (IMD2 high)	
US Cell	835	20	45 (IMD2 low)	-15
			1715 (IMD2 high)	

Table 8: IMD3 Testcases

Band	CW tone 1 (MHz)	CW tone 1 (dBm)	CW tone 2 (MHz)	CW tone 2 (dBm)
IMT	1950	20	1760	-15
US Cell	835	20	790	-15

6 GPIO Specification

Table 9: Modes of Operation (Truth Table)

State	Mode	Control Inputs		
		V1	V2	V3
1	RX1-ANT	0	0	0
2	RX2-ANT	0	0	1
3	RX3-ANT	0	1	0
4	RX4-ANT	0	1	1
5	RX5-ANT	1	0	0
6	RX6-ANT	1	0	1
7	RX7-ANT	1	1	0
8	RX8-ANT	1	1	1

7 Package related information

The switch has a package size of 2000 μm in x-dimension and 2000 μm in y-dimension with a maximum deviation of $\pm 50 \mu\text{m}$ in each dimension. Fig. 2 shows the footprint from top view. The definition of each pin can be found in Tab. 11. In addition a recommendation for the land pattern is displayed in Fig. 4 followed by information regarding laser marking (see Fig. 5).

Table 10: Mechanical Data

Parameter	Symbol	Value	Unit
Package X-Dimension	X	2000 \pm 50	μm
Package Y-Dimension	Y	2000 \pm 50	μm
Package Height	H	0.65 max	μm

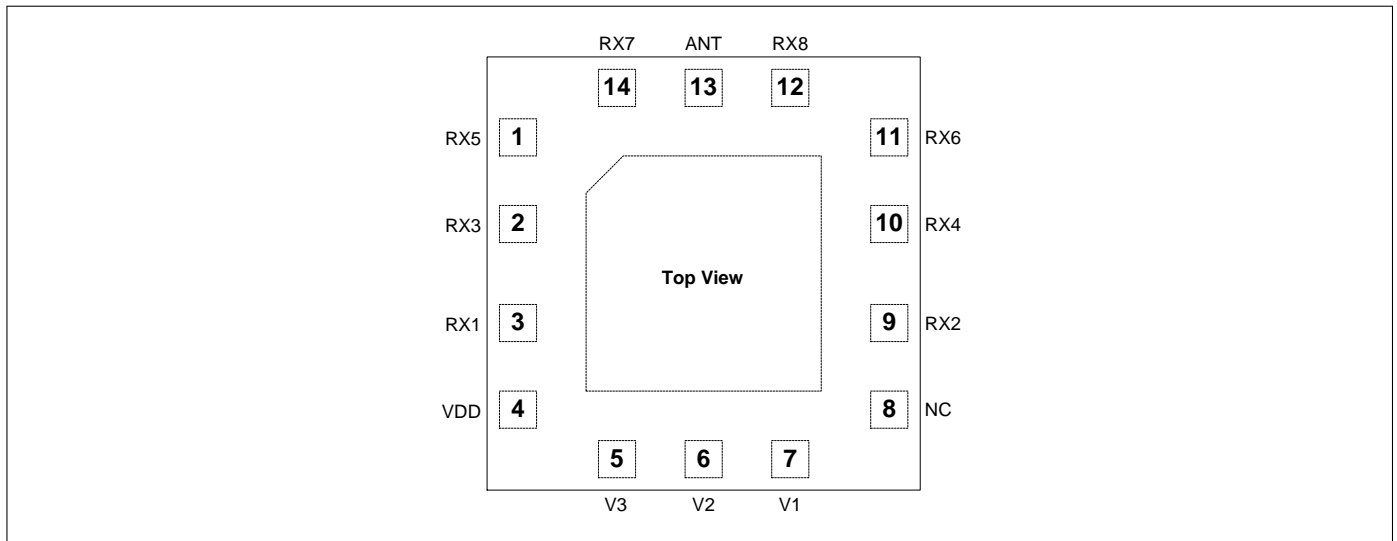

Figure 2: Footprint, top view

Table 11: Pin Definition

No.	Name	Pin Type	Function
0	GND	GND	RF ground; die pad
1	RX5	I/O	RX port 5
2	RX3	I/O	RX port 3
3	RX1	I/O	RX port 1
4	VDD	PWR	V_{DD} supply
5	V3	I	GPIO control pin
6	V2	I	GPIO control pin
7	V1	I	GPIO control pin
8	NC		Not connected
9	RX2	I/O	RX port 2
10	RX4	I/O	RX port 4
11	RX6	I/O	RX port 6
12	RX8	I/O	RX port 8
13	ANT	I/O	Antenna port
14	RX7	I/O	RX port 7

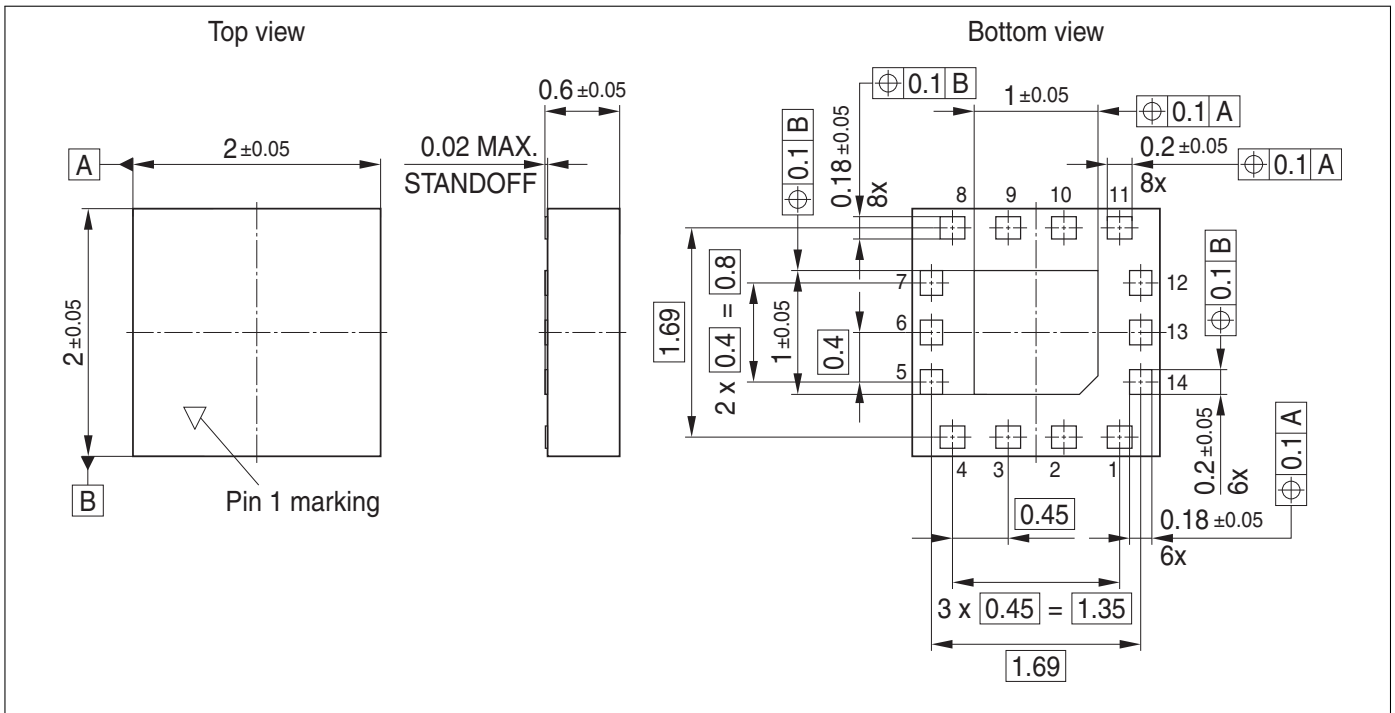

Figure 3: Package Outline Drawing

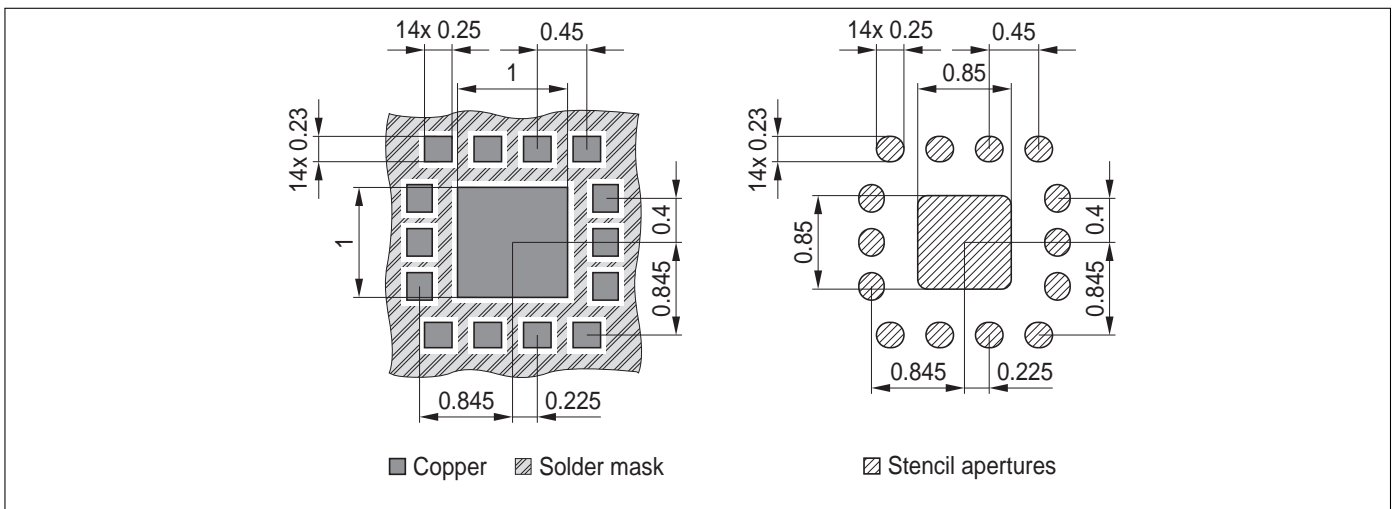

Figure 4: Land Pattern Drawing

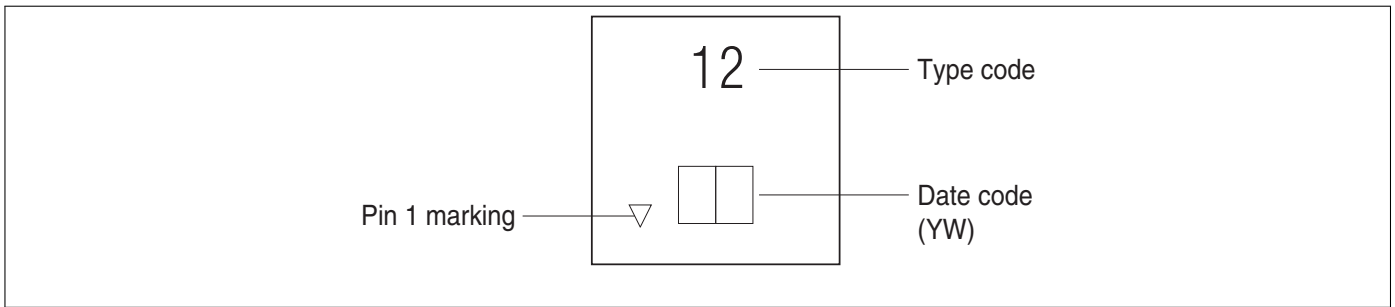

Figure 5: Laser marking

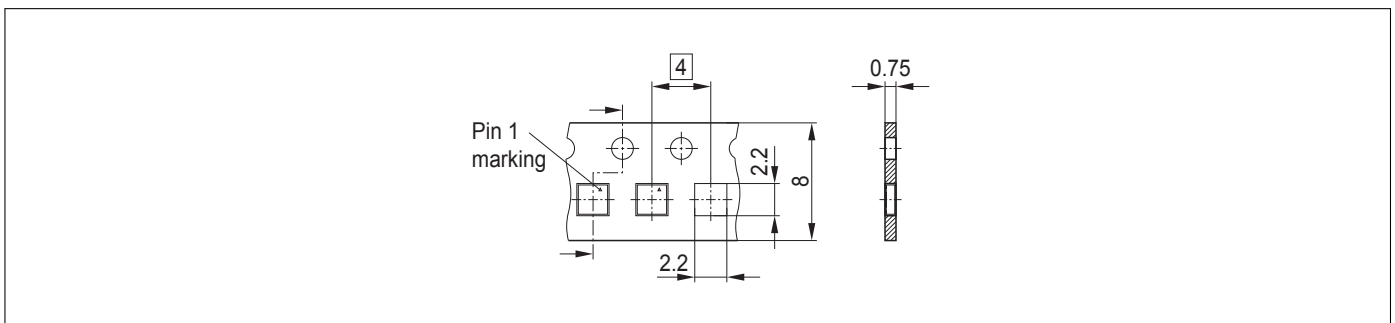



Figure 6: Carrier Tape

www.infineon.com

Published by Infineon Technologies AG

Looking for pricing, stock, or lifecycle information?

Click below to explore more details on WIN SOURCE:

-  [View BGS18GA14E6327XTSA1 on WIN SOURCE](#)
-  [Infineon Technologies Information](#)

Optimize Your Supply Chain with WIN SOURCE Solutions

-  Global Sourcing Solution
-  Obsolete Management
-  Cost Control Management
-  Shortage Management
-  Alternative Solution
-  Excess Inventory Management