



**THE DATASHEET OF
BGF106CE6328XTSA1**



Hipac

High performance passive and actives on chip

BGF106C

SIM Card Interface Filter and ESD Protection

BGF106C

Datasheet

Rev. 3.1, 2013-01-16
Final

Revision History Rev. 3.0, 2011-05-13

Page or Item	Subjects (major changes since previous revision)
Rev. 3.1, 2013-01-16	
4	Features updated

Trademarks of Infineon Technologies AG

AURIX™, C166™, CanPAK™, CIPOS™, CIPURSE™, EconoPACK™, CoolMOS™, CoolSET™, CORECONTROL™, CROSSAVE™, DAVE™, DI-POL™, EasyPIM™, EconoBRIDGE™, EconoDUAL™, EconoPIM™, EconoPACK™, EiceDRIVER™, eupec™, FCOS™, HITFET™, HybridPACK™, I²RF™, ISOFACE™, IsoPACK™, MIPAQ™, ModSTACK™, my-d™, NovalithIC™, OptiMOS™, ORIGA™, POWERCODE™; PRIMARION™, PrimePACK™, PrimeSTACK™, PRO-SIL™, PROFET™, RASIC™, ReverSave™, SatRIC™, SIEGET™, SINDRION™, SIPMOS™, SmartLEWIS™, SOLID FLASH™, TEMPFET™, thinQ!™, TRENCHSTOP™, TriCore™.

Other Trademarks

Advance Design System™ (ADS) of Agilent Technologies, AMBA™, ARM™, MULTI-ICE™, KEIL™, PRIMECELL™, REALVIEW™, THUMB™, μVision™ of ARM Limited, UK. AUTOSAR™ is licensed by AUTOSAR development partnership. Bluetooth™ of Bluetooth SIG Inc. CAT-iq™ of DECT Forum. COLOSSUS™, FirstGPS™ of Trimble Navigation Ltd. EMV™ of EMVCo, LLC (Visa Holdings Inc.). EPCOS™ of Epcos AG. FLEXGO™ of Microsoft Corporation. FlexRay™ is licensed by FlexRay Consortium. HYPERTERMINAL™ of Hilgraeve Incorporated. IEC™ of Commission Electrotechnique Internationale. IrDA™ of Infrared Data Association Corporation. ISO™ of INTERNATIONAL ORGANIZATION FOR STANDARDIZATION. MATLAB™ of MathWorks, Inc. MAXIM™ of Maxim Integrated Products, Inc. MICROTEC™, NUCLEUS™ of Mentor Graphics Corporation. MIPI™ of MIPI Alliance, Inc. MIPS™ of MIPS Technologies, Inc., USA. muRata™ of MURATA MANUFACTURING CO., MICROWAVE OFFICE™ (MWO) of Applied Wave Research Inc., OmniVision™ of OmniVision Technologies, Inc. Openwave™ Openwave Systems Inc. RED HAT™ Red Hat, Inc. RFMD™ RF Micro Devices, Inc. SIRIUS™ of Sirius Satellite Radio Inc. SOLARIS™ of Sun Microsystems, Inc. SPANSION™ of Spansion LLC Ltd. Symbian™ of Symbian Software Limited. TAIYO YUDEN™ of Taiyo Yuden Co. TEAKLITE™ of CEVA, Inc. TEKTRONIX™ of Tektronix Inc. TOKO™ of TOKO KABUSHIKI KAISHA TA. UNIX™ of X/Open Company Limited. VERILOG™, PALLADIUM™ of Cadence Design Systems, Inc. VLYNQ™ of Texas Instruments Incorporated. VXWORKS™, WIND RIVER™ of WIND RIVER SYSTEMS, INC. ZETEX™ of Diodes Zetex Limited.

Last Trademarks Update 2011-11-11

1 SIM Card Interface Filter and ESD Protection

1.1 Features

- ESD protection circuit and interface filter for SIM cards
- ESD protection according to IEC61000-4-2 for ± 15 kV contact discharge on external IOs
- Wafer level package with SnAgCu solder balls
- 400 μm solder ball pitch
- Pb-free (RoHS compliant) and halogen free package

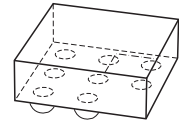

WLP-8-11-N-3D



1.2 Description

BGF106C is an ESD protection circuit and filtering interface for SIM cards. All external IOs are protected against ESD pulses of ± 15 kV contact discharge according to IEC61000-4-2. The wafer level package is a green lead-free and halogen-free package with a size of only 1.2 mm x 1.2 mm and a total height of 0.6 mm

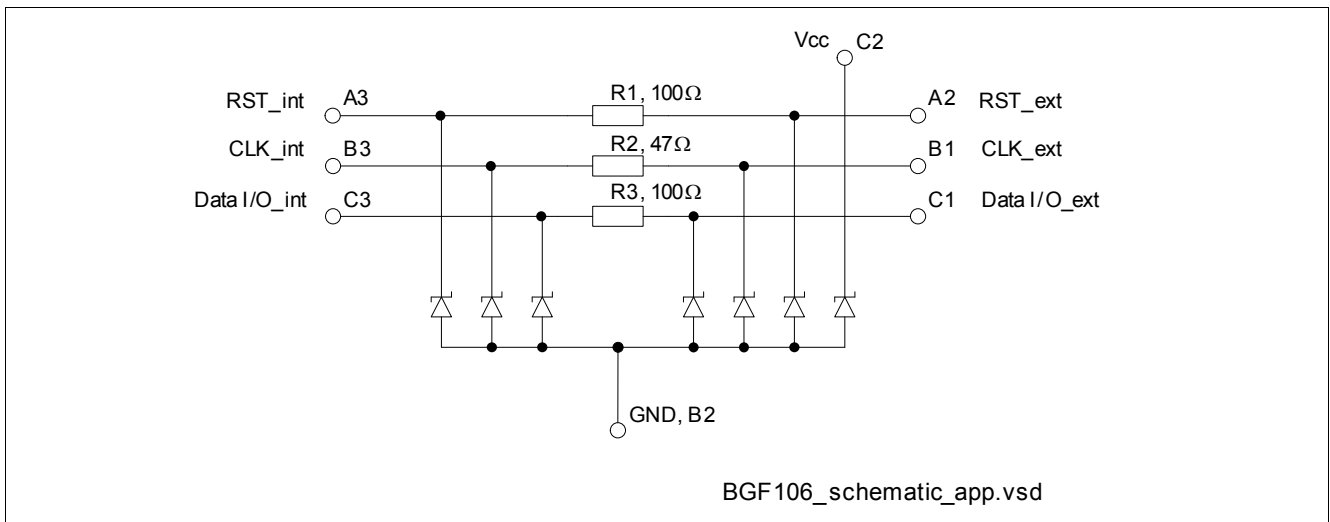

Figure 1-1 Schematic Diagram and Package Configuration

Type	Package	Marking	Chip
BGF106C	WLP-8-11	6C	N0727

2 Characteristics

Table 2-1 Maximum Ratings

Parameter	Symbol	Values			Unit	Note / Test Condition
		Min.	Typ.	Max.		
Voltage at all pins to GND	V_P	0	–	5.5	V	–
Operating temperature range	T_{OP}	-40	–	+85	°	–
Storage temperature range	T_{STG}	-65	–	+150	°C	–
Summed up input power for all pins	P_{in}	–	–	60	mW	$T_S < 70\text{ °C}$
Electrostatic discharge according to IEC61000-4-2						
Contact discharge at internal pins A3, B3, C3 to any other pin	V_{ESD}	-2	–	2	kV	–
Contact discharge at external pins A2, B1, C1, C2 to GND	V_{ESD}	-15	–	15	kV	–

Attention: Stresses above the max. values listed here may cause permanent damage to the device. Exposure to absolute maximum rating conditions for extended periods may affect device reliability. Maximum ratings are absolute ratings; exceeding only one of these values may cause irreversible damage to the integrated circuit.

2.1 Electrical Characteristics

Table 2-2 Electrical Characteristics¹⁾

Parameter	Symbol	Values			Unit	Note / Test Condition
		Min.	Typ.	Max.		
Resistors R_1, R_3	$R_{1,3}$	80	100	120	Ω	–
Resistor R_2	R_2	37.6	47	56.4	Ω	–
Reverse current of ESD protection diodes	I_R	–	1	100	nA	$V = 3\text{ V}$
		–	2	1000	nA	$V = 5\text{ V}$
Breakdown voltage of ESD diodes	$V_{(BR)}$	6.5	7.8	–	V	$I_{(BR)} = 1\text{ mA}$
Line capacitance Capacitance of all lines to GND	C_T	–	16.5	20	pF	$V = 0\text{ V}$

1) at $T_A = 25\text{ °C}$

3 Typical Characteristics

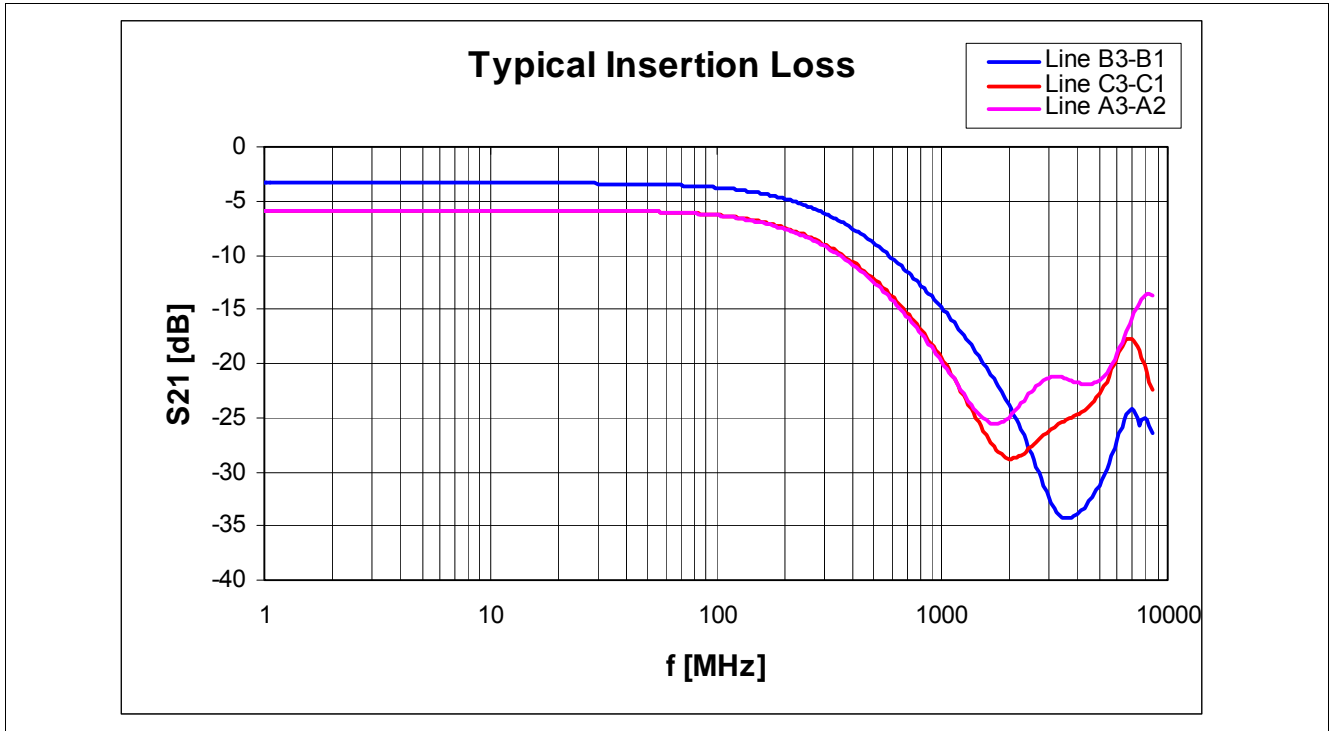

Figure 3-1 Insertion loss, $Z_S=Z_L=50 \Omega$

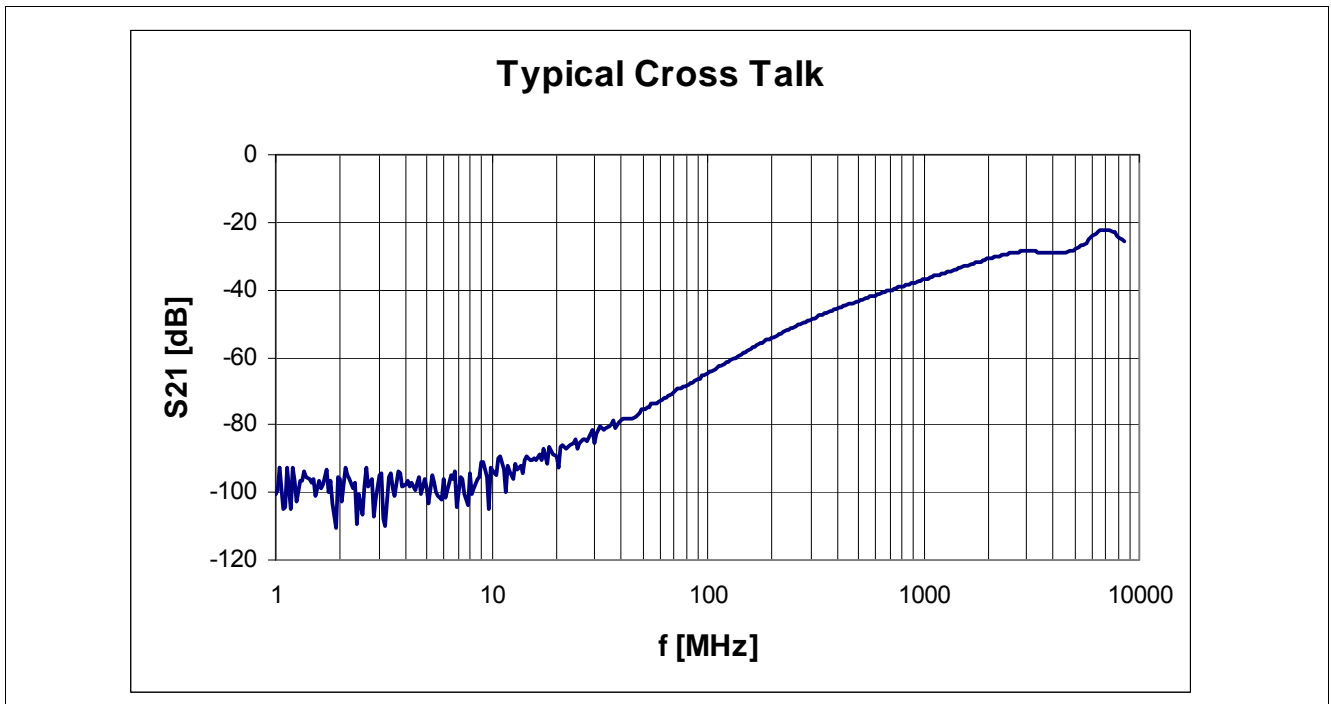

Figure 3-2 Cross talk, $Z_S=Z_L=50 \Omega$ (all unused input and output pins are terminated with 50Ω)

4 Package

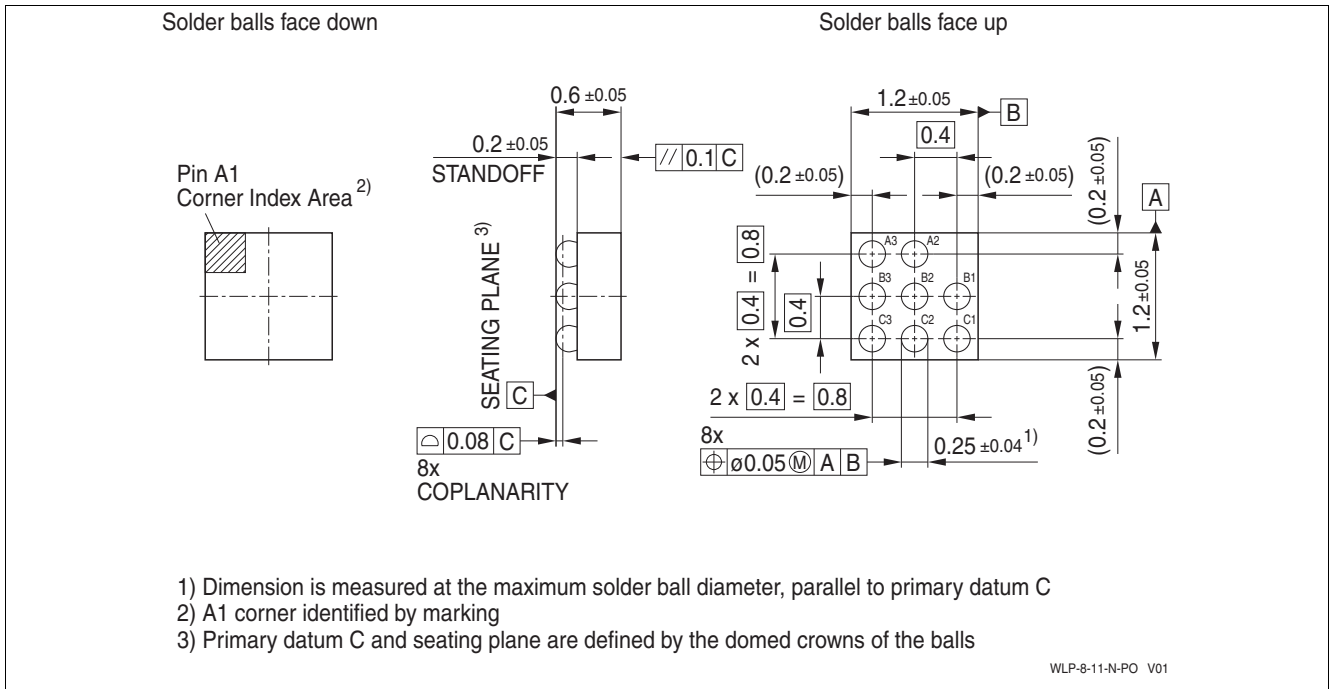

Figure 4-1 WLP-8-11 Package outline (dimension in mm)

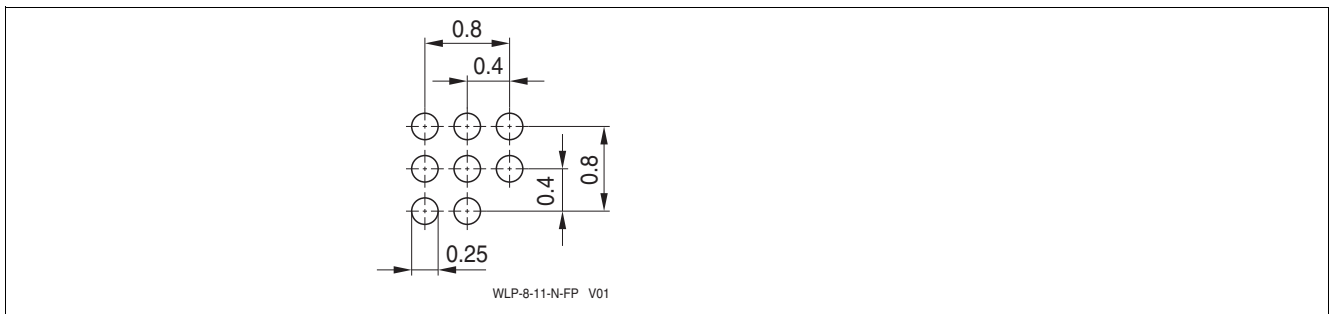

Figure 4-2 WLP-8-11 Footprint (dimension in mm)

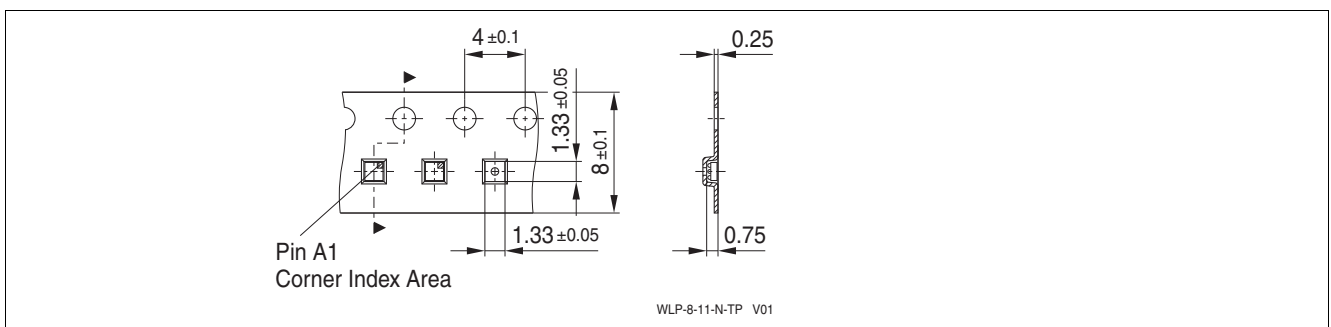



Figure 4-3 WLP-8-11 Packing (dimension in mm)

www.infineon.com

Published by Infineon Technologies AG

Looking for pricing, stock, or lifecycle information?

Click below to explore more details on WIN SOURCE:

-  [View BGF106CE6328XTSA1 on WIN SOURCE](#)
-  [Infineon Technologies Information](#)

Optimize Your Supply Chain with WIN SOURCE Solutions

-  Global Sourcing Solution
-  Obsolete Management
-  Cost Control Management
-  Shortage Management
-  Alternative Solution
-  Excess Inventory Management