



**THE DATASHEET OF
BGC100GN6E6327XTSA1**



BGC100GN6

Switchable Wideband Directional Coupler IC

Data Sheet

Revision 2.3 - 2019-08-07

Edition 2019-08-07

**Published by Infineon Technologies AG
81726 Munich, Germany**

**©2019 Infineon Technologies AG
All Rights Reserved.**

LEGAL DISCLAIMER

The information given in this document shall in no event be regarded as a guarantee of conditions or characteristics. With respect to any examples or hints given herein, any typical values stated herein and/or any information regarding the application of the device, Infineon Technologies hereby disclaims any and all warranties and liabilities of any kind, including without limitation, warranties of non-infringement of intellectual property rights of any third party.

Information

For further information on technology, delivery terms and conditions and prices, please contact the nearest Infineon Technologies Office (www.infineon.com).

Warnings

Due to technical requirements, components may contain dangerous substances. For information on the types in question, please contact the nearest Infineon Technologies Office. Infineon Technologies components may be used in life-support devices or systems only with the express written approval of Infineon Technologies, if a failure of such components can reasonably be expected to cause the failure of that life-support device or system or to affect the safety or effectiveness of that device or system. Life support devices or systems are intended to be implanted in the human body or to support and/or maintain and sustain and/or protect human life. If they fail, it is reasonable to assume that the health of the user or other persons may be endangered.

Revision History

Document No.: BGC100GN6__v2.3.pdf

Revision History: Rev. v2.3

Previous Version: -

Page	Subjects (major changes since last revision)
All	Removed Confidential, NDA required
8	Min. supply voltage

Trademarks of Infineon Technologies AG

μ HVICTM, μ IPMTM, μ PFCTM, AU-ConvertIRTM, AURIXTM, C166TM, CanPAKTM, CIPOSTM, CIPURSETM, CoolDPTM, CoolGaNTM, COOLiRTM, CoolMOSTM, CoolSETTM, CoolSiCTM, DAVETM, DI-POLTM, DirectFETTM, DrBladeTM, EasyPIMTM, EconoBRIDGETM, EconoDUALTM, EconoPACKTM, EconoPIMTM, EiceDRIVERTM, eupecTM, FCOSTM, GaNpowIRTM, HEXFETTM, HITFETTM, HybridPACKTM, iMOTIONTM, IRAMTM, ISOFACETM, IsoPACKTM, LEDrivIRTM, LITIXTM, MIPAQTM, ModSTACKTM, my-dTM, NovalithICTM, OPTIGATM, OptiMOSTM, ORIGATM, PowIRaudioTM, PowIRstageTM, PrimePACKTM, PrimeSTACKTM, PROFETTM, PRO-SiLTM, RASiCTM, REAL3TM, SmartLEWISTM, SOLID FLASHTM, SPOCTM, StrongIRFETTM, SupIRBuckTM, TEMPFETTM, TRENCHSTOPTM, TriCoreTM, UHVICTM, XHPTM, XMCTM.

Other Trademarks

All referenced product or service names and trademarks are the property of their respective owners.

Trademarks updated November 2015

Contents

1	Features	5
2	Product Description	5
3	Maximum Ratings	6
4	Operation Ranges	8
5	RF Characteristics	9
6	RF Large Signal Parameter	10
7	Truth Table	10
8	Application Information	11
9	Package Information	13

List of Figures

1	BGC100GN6 Block diagram	6
2	BGC100GN6 Pin Configuration (top view)	11
3	RF front-end block diagram with BGC100GN6 switchable coupler IC	12
4	TSNP-6-2 Package Outline (top, side and bottom views)	13
5	Marking Specification (top view)	13
6	Footprint Recommendation	14
7	TSNP-6-2 Carrier Tape	14

List of Tables

1	Ordering Information	5
2	Maximum Ratings, Table I	6
3	Maximum Ratings, Table II	7
4	Operation Ranges	8
5	RF Input Power	8
6	RF Characteristics	9
7	Switching Time	9
8	RF Large Signal Specifications	10
9	Truth Table	10
10	Pin Definition and Function	11

BGC100GN6 Switchable Wideband Directional Coupler IC

1 Features

- Fully integrated coupler in RF CMOS
- Bi-directional coupler
- Fitted for feedback receivers to accomplish closed loop power control and antenna tuning
- Wide frequency range: 0.6 to 2.7 GHz
- Designed for low insertion loss and high directivity
- Supports all cellular standards: GSM / WCDMA / HSPA+ / FDD-LTE / TD-LTE / TD-SCDMA / CDMA
- Integrated low-pass filter for 5GHz WiFi jammers suppression
- GPIO controlled
- Small form factor 1.1 mm x 0.7 mm
- RoHS and WEEE compliant package
- Product Validation: Qualified for industrial applications according to the relevant tests of JEDEC47/20/22

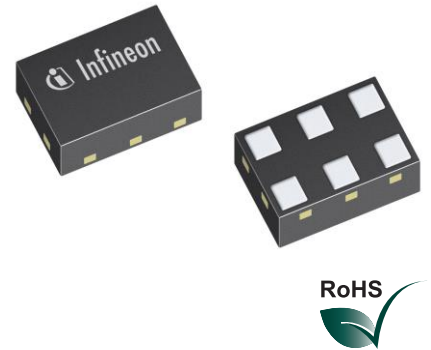

2 Product Description

The BGC100GN6 bi-directional coupler IC is designed for 2G/3G/4G RF front end applications. The device contains a bi-directional coupler operating in one or multiple bands within 0.6 GHz to 2.7 GHz frequency range. The coupled output contains a low-pass filter for 5 GHz ISM blockers suppression. The coupler offers low insertion loss and high directivity.

The coupler is controlled via a GPIO pin. No external power supply blocking or RF decoupling capacitors are required.

The BGC100GN6 is a fully integrated device deploying Infineon high volume RF-CMOS technology. The device has a very small size of only 1.1 x 0.7 mm² and a maximum height of 0.4 mm.

Table 1: Ordering Information

Type	Package	Marking
BGC100GN6	TSNP-6-2	2

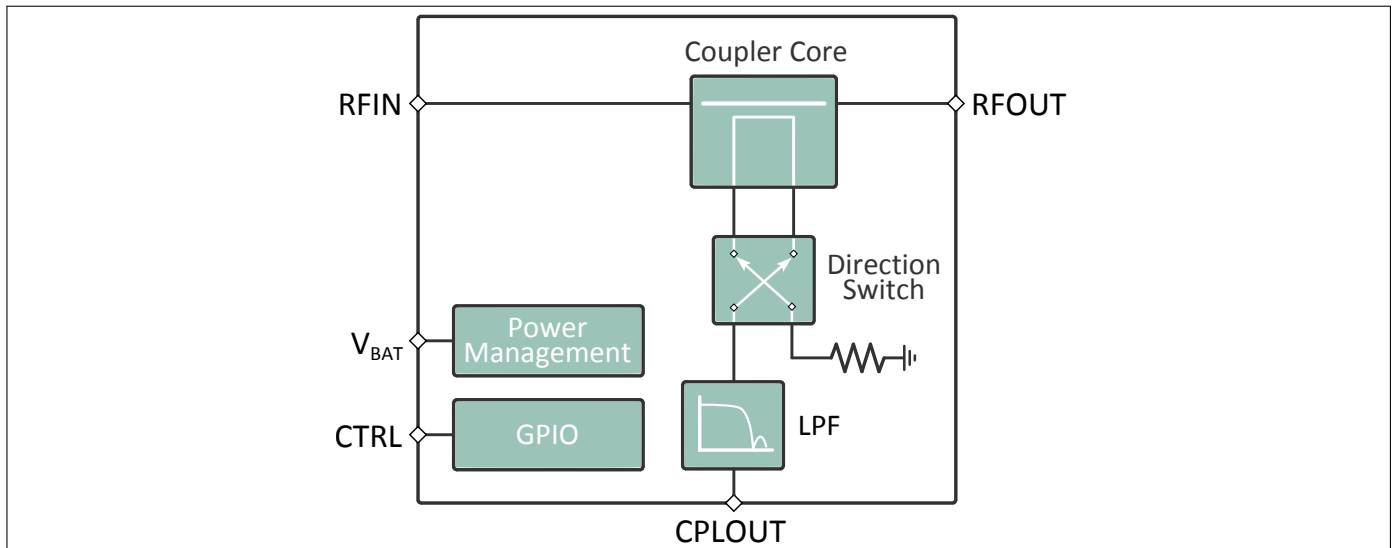
Figure 1: BGC100GN6 Block diagram

3 Maximum Ratings

Table 2: Maximum Ratings, Table I at $T_A = 25\text{ }^\circ\text{C}$, unless otherwise specified

Parameter	Symbol	Values			Unit	Note / Test Condition
		Min.	Typ.	Max.		
Frequency range	f	0.6	–	2.7	GHz	1)
Supply voltage	V_{DD}	-0.5	–	3.6	V	–
Storage temperature range	T_{STG}	-55	–	150	$^\circ\text{C}$	–
Junction temperature	T_j	–	–	125	$^\circ\text{C}$	–
RF input power at RFIN, RFOUT ports	$P_{RF_RFIN, RFOUT}$	–	–	36	dBm	698–960 MHz
		–	–	33	dBm	1400–2200 MHz
		–	–	30	dBm	2300–2700 MHz
ESD capability, CDM ²⁾	V_{ESD_CDM}	-1	–	+1	kV	
ESD capability, HBM ³⁾	V_{ESD_HBM}	-1	–	+1	kV	

¹⁾ There is a DC connection between RFIN and RFOUT. The DC voltage at RF ports V_{RFDC} has to be 0V.

²⁾ Field-Induced Charged-Device Model ANSI/ESDA/JEDEC JS-002. Simulates charging/discharging events that occur in production equipment and processes. Potential for CDM ESD events occurs whenever there is metal-to-metal contact in manufacturing.

³⁾ Human Body Model ANSI/ESDA/JEDEC JS-001 (R=1.5 k Ω , C=100 pF).

Warning: Stresses above the max. values listed here may cause permanent damage to the device. Maximum ratings are absolute ratings; exceeding only one of these values may cause irreversible damage to the integrated circuit. Exposure to conditions at or below absolute maximum rating but above the specified maximum operation conditions may affect device reliability and life time. Functionality of the device might not be given under these conditions.

Table 3: Maximum Ratings, Table II at $T_A = 25\text{ }^\circ\text{C}$, unless otherwise specified

Parameter	Symbol	Values			Unit	Note / Test Condition
		Min.	Typ.	Max.		
Thermal resistance junction - soldering point	R_{thJS}	–	58	–	K/W	–
Maximum DC-voltage on RF-Ports and RF-Ground	V_{RFDC}	0	–	0	V	No DC voltages allowed on RF-Ports

4 Operation Ranges

Table 4: Operation Ranges

Parameter	Symbol	Values			Unit	Note / Test Condition
		Min.	Typ.	Max.		
Supply voltage	V_{DD}	1.6	–	3.4	V	–
Supply current ¹⁾	I_{DD}	–	60	200	μ A	–
GPIO control voltage high	V_{Ctrl_H}	1.35	–	V_{DD} + 0.3	V	Maximum 3.4V
GPIO control voltage low	V_{Ctrl_L}	-0.3	–	0.43	V	–
GPIO control input capacitance	C_{Ctrl}	–	–	2	pF	–
Ambient temperature	T_A	-40	25	85	$^{\circ}$ C	–

¹⁾ $T_A = -40\text{ }^{\circ}\text{C} - 85\text{ }^{\circ}\text{C}$, $V_{DD} = 1.6 - 3.4\text{ V}$
Table 5: RF Input Power

Parameter	Symbol	Values			Unit	Note / Test Condition
		Min.	Typ.	Max.		
RFIN, RFOUT ports (50 Ω)	$P_{RF_RFIN, RFOUT}$	–	–	35	dBm	698–960 MHz
		–	–	32	dBm	1400–2200 MHz
		–	–	29	dBm	2300–2700 MHz, ¹⁾

¹⁾Average LTE power

5 RF Characteristics

Table 6: RF Characteristics at $T_A = -40\text{ }^{\circ}\text{C}-85\text{ }^{\circ}\text{C}$, $P_{IN} = 0\text{ dBm}$, Supply Voltage $V_{DD} = 1.6\text{ V}-3.4\text{ V}$, unless otherwise specified

Parameter	Symbol	Values			Unit	Note / Test Condition
		Min.	Typ.	Max.		
Insertion Loss						
RFIN to RFOUT Ports	IL	-	0.07	0.1	dB	698–960 MHz
		-	0.14	0.2	dB	1400–2200 MHz
		-	0.2	0.3	dB	2300–2700 MHz
Return Loss						
RFIN and RFOUT Ports	RL _{TX}	22	25	-	dB	698–960 MHz
		21	24	-	dB	1400–2200 MHz
		20	21	-	dB	2300–2700 MHz
CPLOUT Port	RL _{CPL}	15	25	-	dB	698–960 MHz
		14	23	-	dB	1400–2200 MHz
		13	20	-	dB	2300–2700 MHz
Coupling Factor						
RFIN and RFOUT to CPLOUT Port	CPL _{LTE}	26	28	30	dB	698–960 MHz
		21	24	25	dB	1400–2200 MHz
		21	23	24	dB	2300–2700 MHz
WiFi Coupling	CPL _{WiFi}	27	33	-	dB	4900–5900 MHz, CTRL=0
		26	29	-	dB	4900–5900 MHz, CTRL=1
Directivity						
CPLOUT to RFOUT vs RFIN, CTRL=0	DIR _{REV}	22	28	-	dB	698–960 MHz
		22	30	-	dB	1400–2200 MHz
		22	25	-	dB	2300–2700 MHz
CPLOUT to RFIN vs RFOUT, CTRL=1	DIR _{FWD}	19	23	-	dB	698–960 MHz
		20	23	-	dB	1400–2200 MHz
		20	22	-	dB	2300–2700 MHz

Table 7: Switching Time at $T_A = -40\text{ }^{\circ}\text{C}-85\text{ }^{\circ}\text{C}$, $P_{IN} = 0\text{ dBm}$, Supply Voltage $V_{DD} = 1.6\text{ V}-3.4\text{ V}$, unless otherwise specified

Parameter	Symbol	Values			Unit	Note / Test Condition
		Min.	Typ.	Max.		
Switching Time						
GPIO to RF switching time	$t_{on/off}$	-	2	5	μs	50 % of GPIO voltage flank to 90 % of target RF amplitude
Power up settling time	t_{PUP}	-	10	25	μs	After power down mode

6 RF Large Signal Parameter

Table 8: RF Large Signal Specifications at $T_A = -40\text{ }^{\circ}\text{C} - 85\text{ }^{\circ}\text{C}$, Supply Voltage $V_{DD} = 1.6\text{ V} - 3.4\text{ V}$, unless otherwise specified

Parameter	Symbol	Values			Unit	Note / Test Condition
		Min.	Typ.	Max.		
Nonlinearity						
Second Harmonic, RFIN, RFOUT Ports	$P_{H2.824.24}$	-	-87	-	dBm	$P_{in}=24\text{ dBm}$, $50\ \Omega$, 824 MHz
Third Harmonic, RFIN, RFOUT Ports	$P_{H3.824.24}$	-	-92	-	dBm	$P_{in}=24\text{ dBm}$, $50\ \Omega$, 824 MHz
Second Harmonic, RFIN, RFOUT Ports	$P_{H2.824.33}$	-	-72	-	dBm	$P_{in}=33\text{ dBm}$, $50\ \Omega$, 824 MHz
Third Harmonic, RFIN, RFOUT Ports	$P_{H3.824.33}$	-	-62	-	dBm	$P_{in}=33\text{ dBm}$, $50\ \Omega$, 824 MHz
Second Harmonic, RFIN, RFOUT Ports	$P_{H2.1800.30}$	-	-78	-	dBm	$P_{in}=30\text{ dBm}$, $50\ \Omega$, 1800 MHz
Third Harmonic, RFIN, RFOUT Ports	$P_{H3.1800.30}$	-	-73	-	dBm	$P_{in}=30\text{ dBm}$, $50\ \Omega$, 1800 MHz
IMD2, B39+B41, F_2-F_1 , RFIN, RFOUT Ports	IMD_2	-	-77	-	dBm	$P_1=P_2=24\text{ dBm}$, $F_1=1.9\text{ GHz}$, $F_2=2.6\text{ GHz}$, $F_{IMD2}=700\text{ MHz}$
IMD3, B39+B41, $2F_2-F_1$, RFIN, RFOUT Ports	IMD_3	-	-75	-	dBm	$P_1=P_2=24\text{ dBm}$, $F_1=1.9\text{ GHz}$, $F_2=2.6\text{ GHz}$, $F_{IMD3}=3.3\text{ GHz}$
IMD4, B39+B41, $2F_2-2F_1$, RFIN, RFOUT Ports	$IMD_{4.1}$	-	-100	-	dBm	$P_1=P_2=24\text{ dBm}$, $F_1=1.9\text{ GHz}$, $F_2=2.6\text{ GHz}$, $F_{IMD4.1}=1.4\text{ GHz}$
IMD4, B39+B41, $3F_2-F_1$, RFIN, RFOUT Ports	$IMD_{4.2}$	-	-98	-	dBm	$P_1=P_2=24\text{ dBm}$, $F_1=1.9\text{ GHz}$, $F_2=2.6\text{ GHz}$, $F_{IMD4.2}=5.9\text{ GHz}$

7 Truth Table

Table 9: Modes of Operation (Truth Table)

State	Mode	CTRL
1	RF signal propagating from RFOUT to RFIN is coupled into CPLOUT	0
2	RF signal propagating from RFIN to RFOUT is coupled into CPLOUT	1

8 Application Information

Pin Configuration and Function

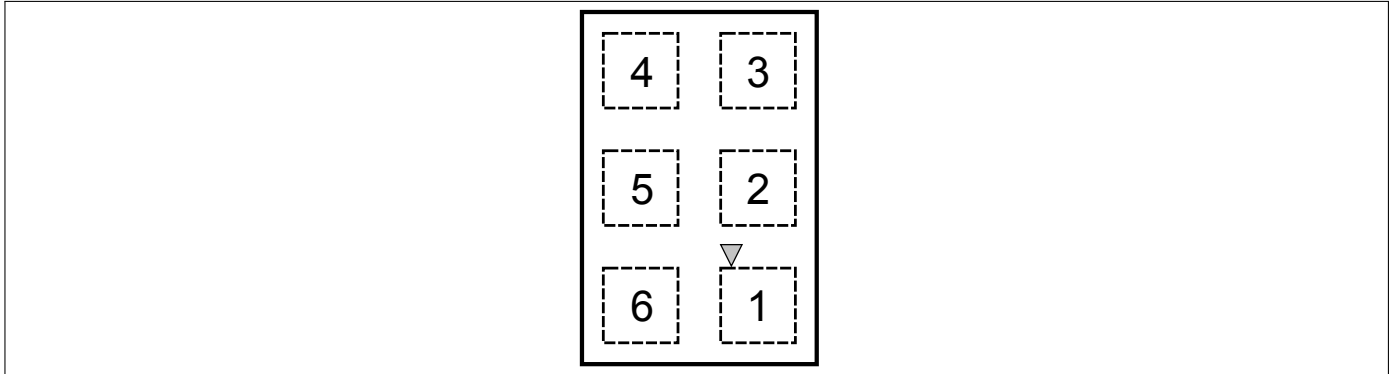

Figure 2: BGC100GN6 Pin Configuration (top view)

Table 10: Pin Definition and Function

Pin No.	Name	Function
1	RFOUT	Main Path Output Port
2	V _{DD}	Supply Voltage
3	CTRL	Control Pin
4	CPLOUT	Coupled Output
5	GND	Ground
6	RFIN	Main Path Input Port

RF Front-End Example

Figure 3: RF front-end block diagram with BGC100GN6 switchable coupler IC

BGC100GN6 switchable coupler IC is optimized for RF front-end applications, where it is a part of power control and antenna tuning loops. The BGC100GN6 IC exhibits 3 to 6 dB higher directivity and 3 to 5 dB higher WiFi jammer suppression when it is configured to operate in reverse mode, i.e. when incident RF signal is propagating from RFOUT towards RFIN pins of the IC and reflected signal is propagating from RFIN towards RFOUT pins of the IC. Figure 3 demonstrates an example of BGC100GN6 IC connected in reverse mode in a generic RF front-end of cellular handheld device. The RFOUT pin is coupled to the PA/antenna switch module, while RFIN pin is coupled to antenna side. The benefits of such configuration (as opposed to configuration where RFOUT and RFIN pins are swept in the main RF path) for the application are:

- higher accuracy of power control loop due to lower peak-to-peak forward coupled power variation over the angle for a given antenna VSWR;
- 30...35 dB WiFi signal suppression parasitically coupled into LTE antenna. Such suppression prevents feedback receiver from downconverting the WiFi blockers at frequencies which are the integer multiples of target LTE signal.

Please check the truth table for GPIO control pin to ensure that forward and reverse directions are correctly configured.

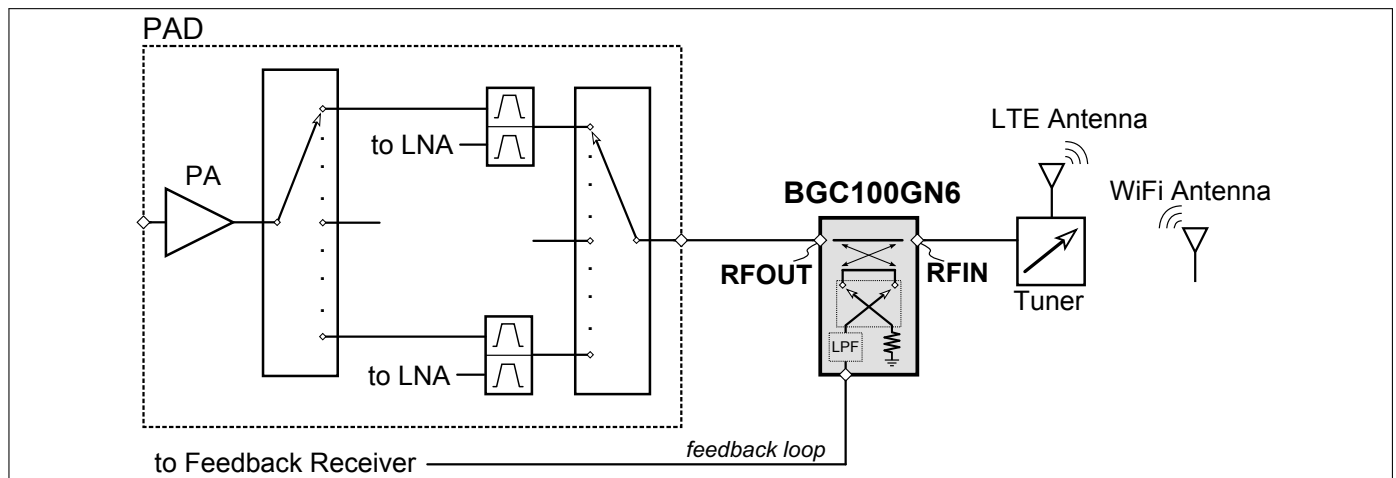
9 Package Information

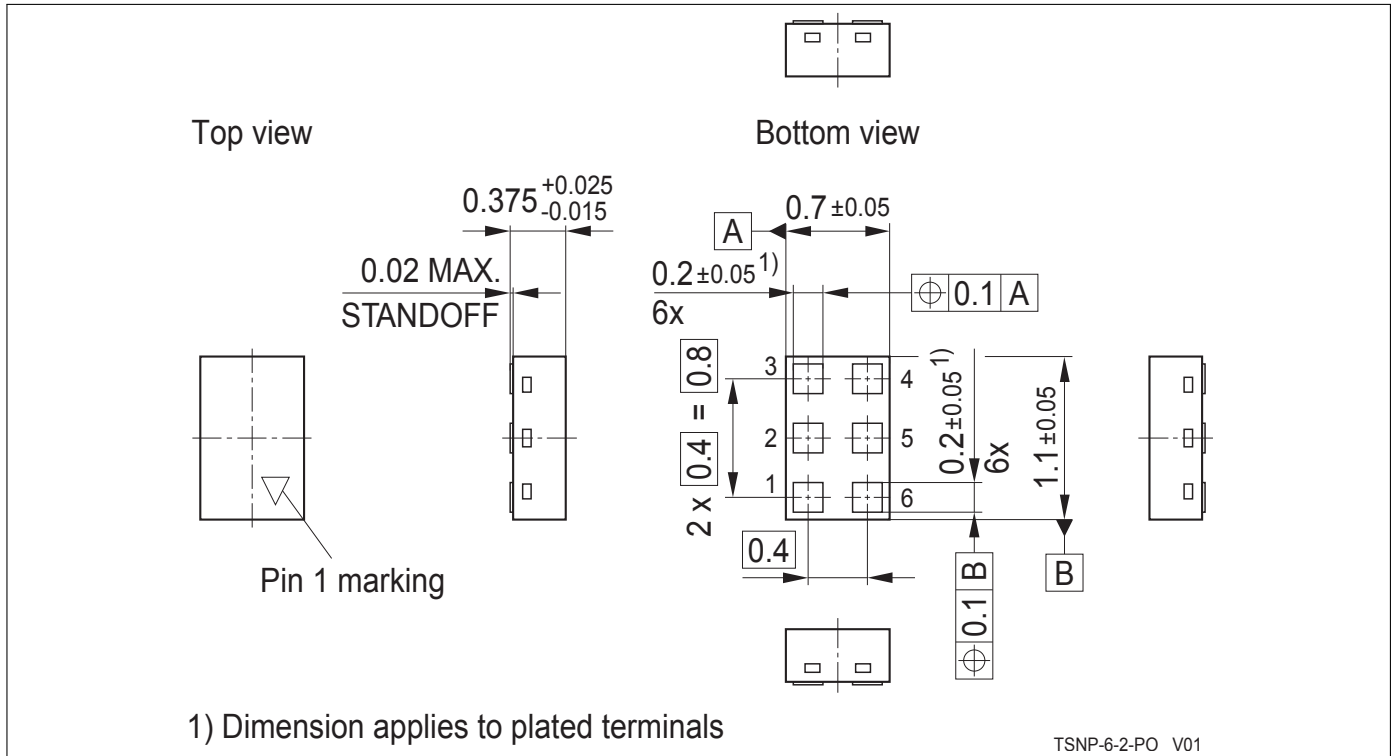

Figure 4: TSNP-6-2 Package Outline (top, side and bottom views)

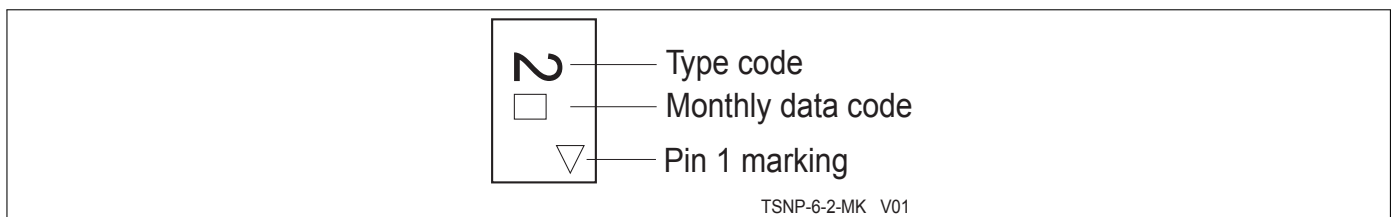

Figure 5: Marking Specification (top view)

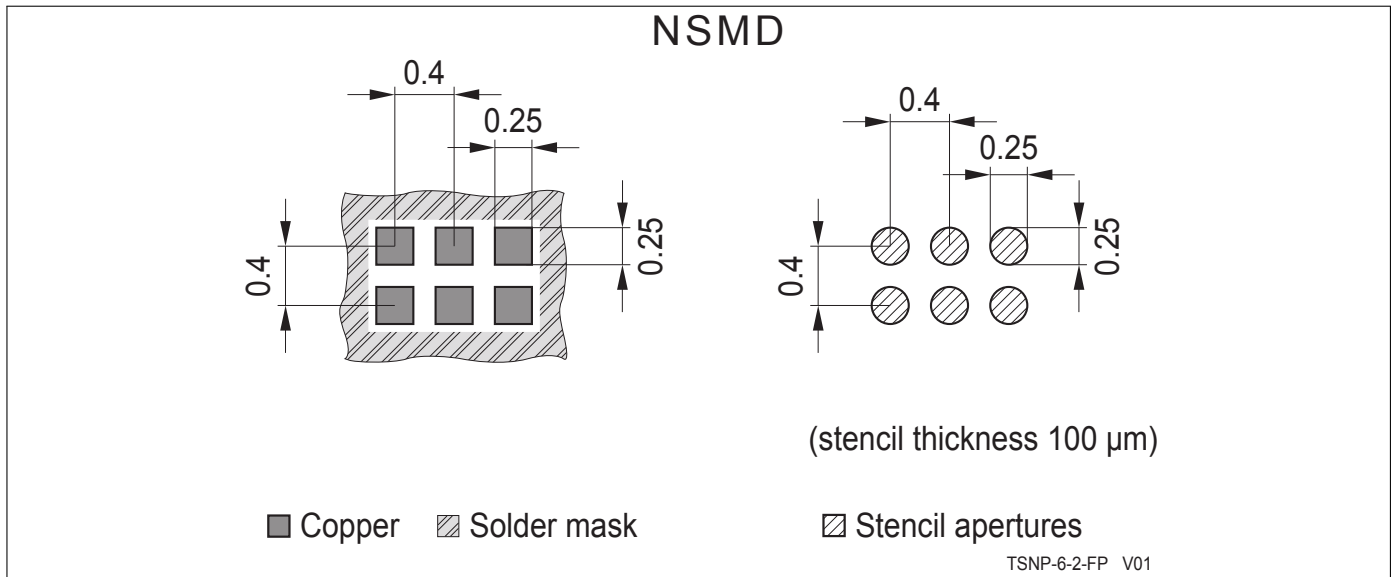

Figure 6: Footprint Recommendation

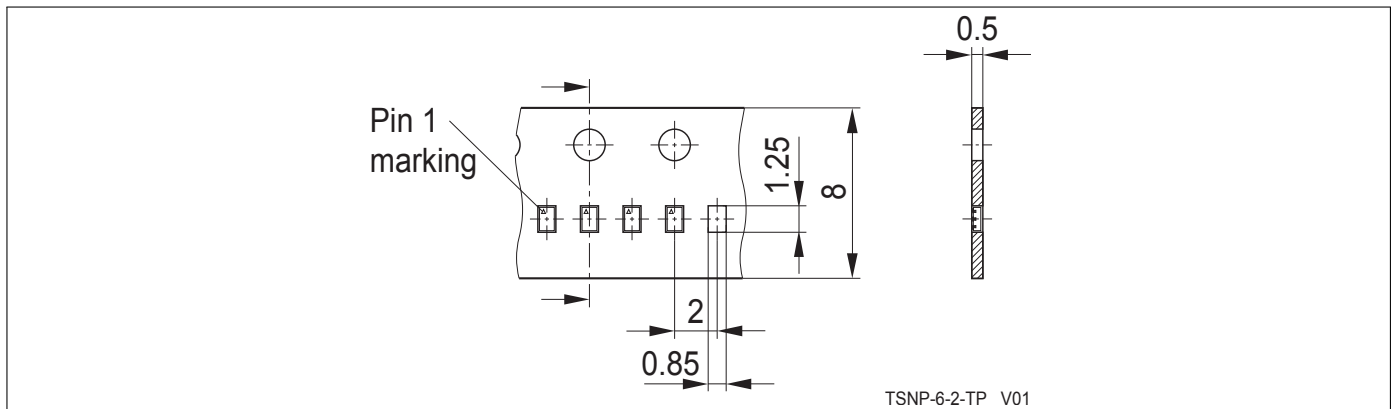

Figure 7: TSNP-6-2 Carrier Tape

www.infineon.com

Published by Infineon Technologies AG

Looking for pricing, stock, or lifecycle information?

Click below to explore more details on WIN SOURCE:

- ⊖ [View BGC100GN6E6327XTSA1 on WIN SOURCE](#)
- ⊖ [Infineon Technologies Information](#)

Optimize Your Supply Chain with WIN SOURCE Solutions

- ✓ Global Sourcing Solution
- ✓ Obsolete Management
- ✓ Cost Control Management
- ✓ Shortage Management
- ✓ Alternative Solution
- ✓ Excess Inventory Management