



**THE DATASHEET OF
BGA736L16E6327XTSA1**



BGA736L16

Tri-Band HSDPA LNA

(2100, 1900/2100, 800/900 MHz)

RF & Protection Devices



Never stop thinking

Edition 2008-07-03

**Published by
Infineon Technologies AG
81726 München, Germany**

**© Infineon Technologies AG 2009.
All Rights Reserved.**

Legal Disclaimer

The information given in this document shall in no event be regarded as a guarantee of conditions or characteristics ("Beschaffenhheitsgarantie"). With respect to any examples or hints given herein, any typical values stated herein and/or any information regarding the application of the device, Infineon Technologies hereby disclaims any and all warranties and liabilities of any kind, including without limitation warranties of non-infringement of intellectual property rights of any third party.

Information

For further information on technology, delivery terms and conditions and prices please contact your nearest Infineon Technologies Office (www.infineon.com).

Warnings

Due to technical requirements components may contain dangerous substances. For information on the types in question please contact your nearest Infineon Technologies Office.

Infineon Technologies Components may only be used in life-support devices or systems with the express written approval of Infineon Technologies, if a failure of such components can reasonably be expected to cause the failure of that life-support device or system, or to affect the safety or effectiveness of that device or system. Life support devices or systems are intended to be implanted in the human body, or to support and/or maintain and sustain and/or protect human life. If they fail, it is reasonable to assume that the health of the user or other persons may be endangered.

BGA736L16**Revision History: 2008-07-03, V2.1****Previous Version: 2008-02-27, V2.0**

Page	Subjects (major changes since last revision)
5, 6	Updated HBM ESD protection
11	Added RF characteristics for UMTS band VIII
13	Added RF characteristics for UMTS band IV
39	Added application circuit schematic for UMTS bands I, IV and VIII
all	Updated values for high and mid gain currents

Table of Contents

	Table of Contents	4
1	Description	5
2	Electrical Characteristics	6
2.1	Absolute Maximum Ratings	6
2.2	Thermal Resistance	6
2.3	ESD Integrity	6
2.4	DC Characteristics	7
2.5	Band Select / Gain Control Truth Table	7
2.6	Supply current characteristics; $T_A = 25\text{ }^\circ\text{C}$	8
2.7	Logic Signal Characteristics; $T_A = 25\text{ }^\circ\text{C}$	9
2.8	Switching Times	9
2.9	Measured RF Characteristics Low Band	10
2.9.1	Measured RF Characteristics UMTS Band V	10
2.9.2	Measured RF Characteristics UMTS Band VIII	11
2.10	Measured RF Characteristics Mid Band	12
2.10.1	Measured RF Characteristics UMTS Band II	12
2.10.2	Measured RF Characteristics UMTS Band IV	13
2.11	Measured RF Characteristics High Band	14
2.11.1	Measured RF Characteristics UMTS Band I	14
2.12	Measured Performance Low Band High Gain Mode vs. Frequency	15
2.13	Measured Performance Low Band High Gain Mode vs. Temperature	16
2.14	Measured Performance Low Band Mid Gain Mode vs. Frequency	17
2.15	Measured Performance Low Band Mid Gain Mode vs. Temperature	19
2.16	Measured Performance Low Band Low Gain Mode vs. Frequency	20
2.17	Measured Performance Low Band Low Gain Mode vs. Temperature	21
2.18	Measured Performance Mid Band High Gain Mode vs. Frequency	22
2.19	Measured Performance Mid Band High Gain Mode vs. Temperature	24
2.20	Measured Performance Mid Band Mid Gain Mode vs. Frequency	25
2.21	Measured Performance Mid Band Mid Gain Mode vs. Temperature	26
2.22	Measured Performance Mid Band Low Gain Mode vs. Frequency	27
2.23	Measured Performance Mid Band Low Gain Mode vs. Temperature	29
2.24	Measured Performance High Band High Gain Mode vs. Frequency	30
2.25	Measured Performance High Band High Gain Mode vs. Temperature	31
2.26	Measured Performance High Band Mid Gain Mode vs. Frequency	32
2.27	Measured Performance High Band Mid Gain Mode vs. Temperature	34
2.28	Measured Performance High Band Low Gain Mode vs. Frequency	35
2.29	Measured Performance High Band Low Gain Mode vs. Temperature	36
3	Application Circuit and Block Diagram	38
3.1	UMTS bands I, II and V Application Circuit Schematic	38
3.2	UMTS bands I, IV and VIII Application Circuit Schematic	39
3.3	Pin Definition	40
3.4	Application Board	41
4	Physical Characteristics	43
4.1	Package Footprint	43
4.2	Package Dimensions	44

1 Description

The BGA736L16 is a highly flexible, tri-gain mode, and tri-band (2100, 1900/2100, 800/900 MHz) MMIC low noise amplifier for worldwide use. Based on Infineon's proprietary and cost-effective SiGe:C technology, the BGA736L16 features dynamic gain control, temperature stabilization, standby mode, and 2 kV ESD protection on-chip and matching off chip.

While two gain modes are common in W-CDMA systems, a third gain mode has been introduced to reduce the LNA gain just enough to pass adjacent channel tests without compromising on HSDPA performance. The 1900 MHz path can be converted into a 2100 MHz path and vice versa by optimizing the input matching and using an additional external output matching network. This document specifies device performance for the band combinations - UMTS bands I / II / V and UMTS bands I / IV / VIII.

Features

- Gain: 16 / 3 / -8 dB in high / mid / low gain mode
- Noise figure: 1.1 dB in high gain mode
- Supply current: 5.3 / 5.3 / 0.85 mA in high / mid / low gain modes
- Standby mode current consumption < 2 μ A
- Outputs internally matched to 50 Ω
- 2 kV HBM ESD protection
- Low external component count
- Small leadless TSLP-16-1 package (2.3 x 2.3 x 0.39 mm)
- Pb-free (RoHS compliant) package

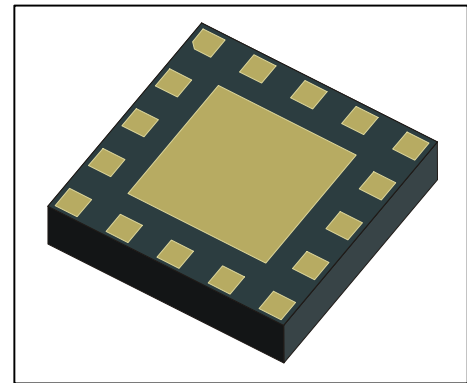

TSLP-16-1 package

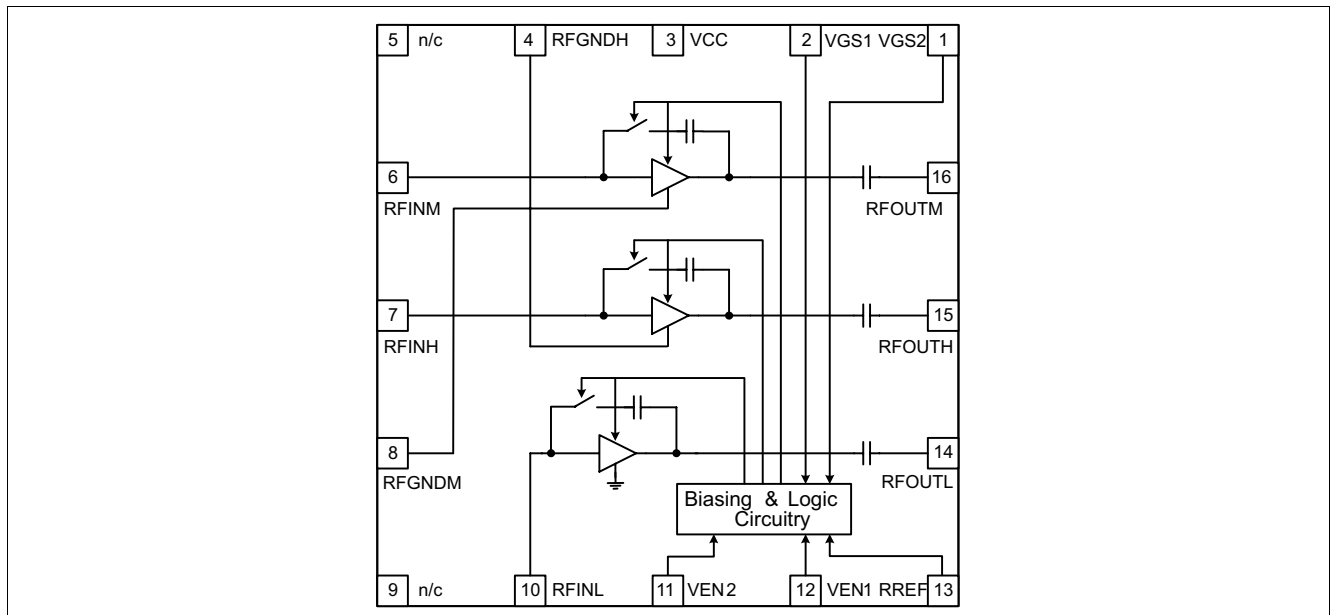

Figure 1 Block diagram of triple-band LNA

Type	Package	Marking	Chip
BGA736L16	PG-TSLP-16-1	BGA736	T1540

2 Electrical Characteristics

2.1 Absolute Maximum Ratings

Table 1 Absolute Maximum Ratings

Parameter	Symbol	Values		Unit	Note / Test Condition
		Min.	Max.		
Supply voltage	V_{CC}	-0.3	3.6	V	
Supply current	I_{CC}		10	mA	
Pin voltage	V_{PIN}	-0.3	$V_{CC} + 0.3$	V	All pins except RF input pins
Pin voltage RF input pins	V_{RFIN}	-0.3	0.9	V	
RF input power	P_{RFIN}		4	dBm	
Junction temperature	T_j		150	°C	
Ambient temperature range	T_A	-30	85	°C	
Storage temperature range	T_{STG}	-65	150	°C	

2.2 Thermal Resistance

Table 2 Thermal Resistance

Parameter	Symbol	Value	Unit	Note / Test Conditions
Thermal resistance junction to soldering point	R_{thJS}	≤ 110	K/W	

2.3 ESD Integrity

Table 3 ESD Integrity

Parameter	Symbol	Value	Unit	Note / Test Conditions
		Typ.		
ESD hardness HBM ¹⁾	$V_{ESD-HBM}$	2000	V	All pins

1) According to JESD22-A114

2.4 DC Characteristics

Table 4 DC Characteristics, $T_A = 25\text{ °C}$

Parameter	Symbol	Values			Unit	Note / Test Condition
		Min.	Typ.	Max.		
Supply voltage	V_{CC}	2.7	2.8	3.0	V	
Supply current high and mid gain mode	I_{CCHG} I_{CCMG}		4.3 5.3 6.4		mA mA mA	All bands Supply current is proportional to absolute temperature
Supply current low gain mode	I_{CCLG}		850		μA	All bands
Supply current standby mode	I_{CCOFF}		0.1	2	μA	
Logic level high	V_{HI}	1.5	2.8		V	VEN1 and VEN2
Logic level low	V_{LOW}		0.0	0.5	V	
Logic currents VEN	I_{ENL}		0.2		μA	VEN1 and VEN2
	I_{ENH}		10.0		μA	
Logic currents VGS	I_{GSL}		0.1		μA	VGS
	I_{GSH}		5.0		μA	

2.5 Band Select / Gain Control Truth Table

Table 5 Band Select Truth Table, $V_{CC} = 2.8\text{ V}$

	High band	Mid band	Low band	Standby mode
VEN1	H	H	L	L
VEN2	H	L	H	L

Table 6 Gain Control Truth Table, $V_{CC} = 2.8\text{ V}$

	High Gain	Mid Gain	Low Gain
VGS1	H	H	L
VGS2	L	H	L

2.6 Supply current characteristics; $T_A = 25\text{ }^\circ\text{C}$

Supply current high / mid gain mode versus reference resistor R_{REF} (see [Figure 2 on page 38](#) for reference resistor; low gain mode supply current is independent of reference resistor).

Supply Current Highband $I_{CC} = f(R_{REF})$
 $V_{CC} = 2.8\text{ V}$

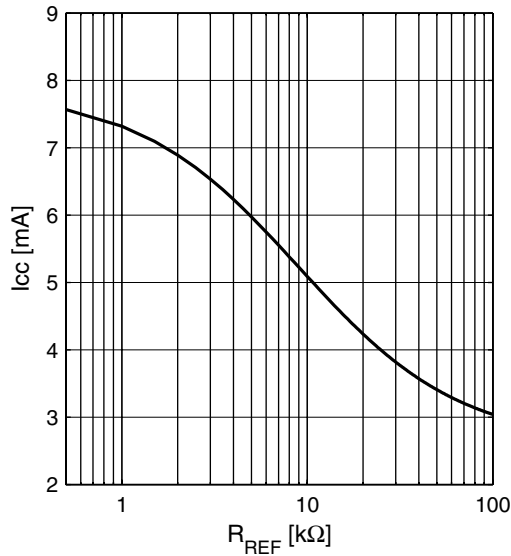

Supply Current Midband $I_{CC} = f(R_{REF})$
 $V_{CC} = 2.8\text{ V}$

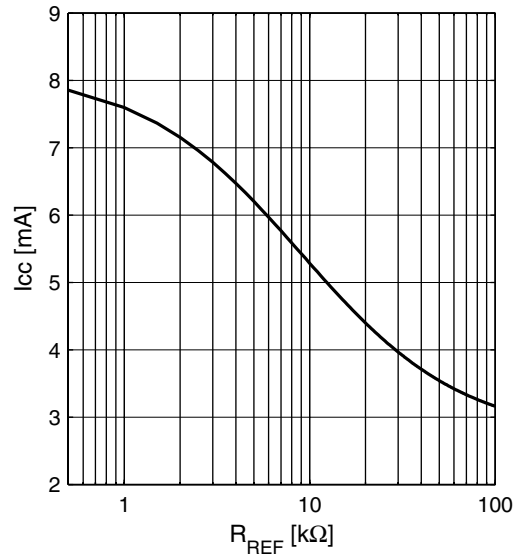

Supply Current Lowband $I_{CC} = f(R_{REF})$
 $V_{CC} = 2.8\text{ V}$

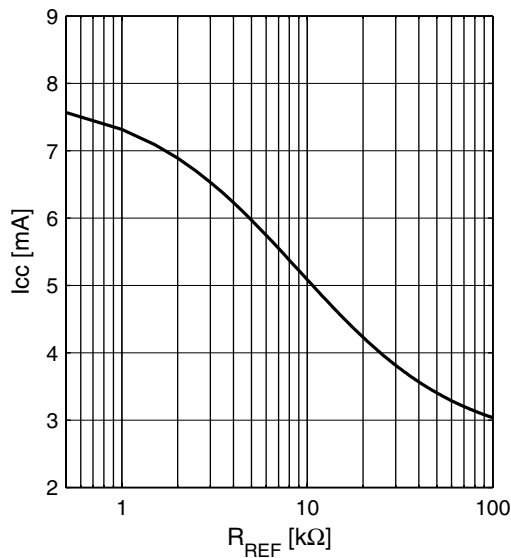

2.7 Logic Signal Characteristics; $T_A = 25\text{ °C}$

Current consumption of logic inputs VEN1, VEN2, VGS1, VGS2

Logic Currents $I_{EN1,2} = f(V_{EN1,2})$
 $V_{CC} = 2.8\text{ V}$

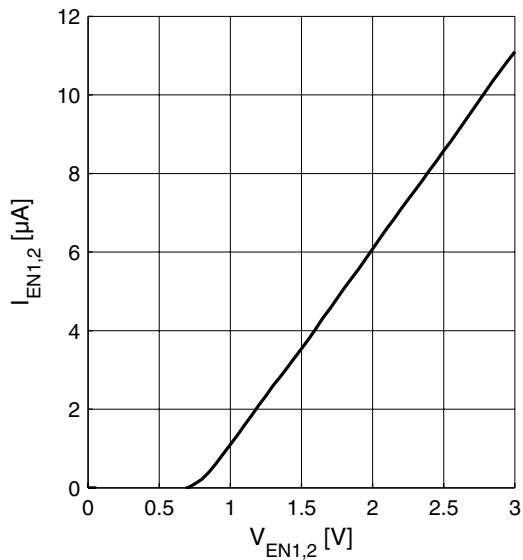

Logic Currents $I_{GS1,2} = f(V_{GS1,2})$
 $V_{CC} = 2.8\text{ V}$

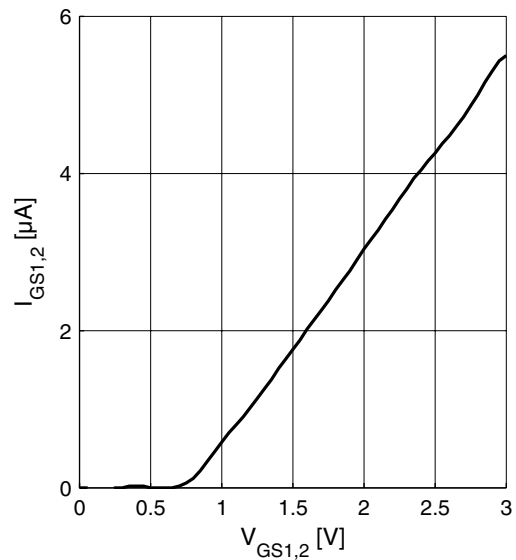

2.8 Switching Times

Table 7 Typical switching times; $T_A = -30 \dots 85\text{ °C}$

Parameter	Symbol	Values			Unit	Note / Test Condition
		Min.	Typ.	Max.		
Settling time gainstep	t_{GS}		1		μs	Switching from any gain mode to a different gain mode; all bands
Settling time bandselect	t_{BS}		1.6		μs	Switching from any band to a different band; all gain modes

2.9 Measured RF Characteristics Low Band

2.9.1 Measured RF Characteristics UMTS Band V

Table 8 Typical Characteristics 800 MHz Band, $T_A = 25\text{ °C}$, $V_{CC} = 2.8\text{ V}$, $R_{REF} = 8.2\text{ k}\Omega$

Parameter	Symbol	Values			Unit	Note / Test Condition
		Min.	Typ.	Max.		
Pass band range		869		894	MHz	
Current consumption	I_{CCHG}		5.20		mA	High gain mode
	I_{CCMG}		5.20		mA	Mid gain mode
	I_{CCLG}		0.85		mA	Low gain mode
Gain	S_{21HG}		15.5		dB	High gain mode
	S_{21MG}		3.0		dB	Mid gain mode
	S_{21LG}		-8.9		dB	Low gain mode
Reverse Isolation ¹⁾	S_{12HG}		-38		dB	High gain mode
	S_{12MG}		-40		dB	Mid gain mode
	S_{12LG}		-9		dB	Low gain mode
Noise figure	NF_{HG}		1.1		dB	High gain mode
	NF_{MG}		2.4		dB	Mid gain mode
	NF_{LG}		9.0		dB	Low gain mode
Input return loss ¹⁾	S_{11HG}		-14		dB	50 Ω , high gain mode
	S_{11MG}		-12		dB	50 Ω , mid gain mode
	S_{11LG}		-10		dB	50 Ω , low gain mode
Output return loss ¹⁾	S_{22HG}		-20		dB	50 Ω , high gain mode
	S_{22MG}		-22		dB	50 Ω , mid gain mode
	S_{22LG}		-18		dB	50 Ω , low gain mode
Stability factor ²⁾	k		>3.1			DC to 10 GHz; all gain modes
Input compression point ¹⁾	IP_{1dBHG}		-11		dBm	High gain mode
	IP_{1dBMG}		-10		dBm	Mid gain mode
	$IP_{1dB LG}$		-12		dBm	Low gain mode
Inband IIP3 ¹⁾ $f_1 - f_2 = 1\text{ MHz}$ $P_{f1} = P_{f2} = -25\text{ dBm}$	$IIP3_{HG}$		-5		dBm	High gain mode
	$IIP3_{MG}$		-5			Mid gain mode
	$IIP3_{LG}$		-3			Low gain mode

1) Verified by random sampling; not 100% RF tested

2) Not tested in production; guaranteed by device design

2.9.2 Measured RF Characteristics UMTS Band VIII
Table 9 Typical Characteristics 900 MHz Band, $T_A = 25\text{ °C}$, $V_{CC} = 2.8\text{ V}$, $R_{REF} = 8.2\text{ k}\Omega$

Parameter	Symbol	Values			Unit	Note / Test Condition
		Min.	Typ.	Max.		
Pass band range		925		960	MHz	
Current consumption	I_{CCHG}		5.20		mA	High gain mode
	I_{CCMG}		5.20		mA	Mid gain mode
	I_{CCLG}		0.85		mA	Low gain mode
Gain	S_{21HG}		15.2		dB	High gain mode
	S_{21MG}		2.8		dB	Mid gain mode
	S_{21LG}		-8.8		dB	Low gain mode
Reverse Isolation ¹⁾	S_{12HG}		-37		dB	High gain mode
	S_{12MG}		-39		dB	Mid gain mode
	S_{12LG}		-9		dB	Low gain mode
Noise figure	NF_{HG}		1.2		dB	High gain mode
	NF_{MG}		2.6		dB	Mid gain mode
	NF_{LG}		9.0		dB	Low gain mode
Input return loss ¹⁾	S_{11HG}		-14		dB	50 Ω , high gain mode
	S_{11MG}		-12		dB	50 Ω , mid gain mode
	S_{11LG}		-11		dB	50 Ω , low gain mode
Output return loss ¹⁾	S_{22HG}		-20		dB	50 Ω , high gain mode
	S_{22MG}		-19		dB	50 Ω , mid gain mode
	S_{22LG}		-19		dB	50 Ω , low gain mode
Stability factor ²⁾	k		>3.4			DC to 10 GHz; all gain modes
Input compression point ¹⁾	IP_{1dBHG}		-9		dBm	High gain mode
	IP_{1dBMG}		-5		dBm	Mid gain mode
	$IP_{1dB LG}$		-11		dBm	Low gain mode
Inband IIP3 ¹⁾ $f_1 - f_2 = 1\text{ MHz}$ $P_{f1} = P_{f2} = -25\text{ dBm}$	$IIP3_{HG}$		-5		dBm	High gain mode
	$IIP3_{MG}$		-5			Mid gain mode
	$IIP3_{LG}$		-3			Low gain mode

1) Verified by random sampling; not 100% RF tested

2) Not tested in production; guaranteed by device design

2.10 Measured RF Characteristics Mid Band

2.10.1 Measured RF Characteristics UMTS Band II

Table 10 Typical Characteristics 1900 MHz Band, $T_A = 25\text{ °C}$, $V_{CC} = 2.8\text{ V}$, $R_{REF} = 8.2\text{ k}\Omega$

Parameter	Symbol	Values			Unit	Note / Test Condition
		Min.	Typ.	Max.		
Pass band range		1930		1990	MHz	
Current consumption	I_{CCHG}		5.30		mA	High gain mode
	I_{CCMG}		5.30		mA	Mid gain mode
	I_{CCLG}		0.85		mA	Low gain mode
Gain	S_{21HG}		16.1		dB	High gain mode
	S_{21MG}		2.7		dB	Mid gain mode
	S_{21LG}		-8.1		dB	Low gain mode
Reverse Isolation ¹⁾	S_{12HG}		-35		dB	High gain mode
	S_{12MG}		-36		dB	Mid gain mode
	S_{12LG}		-8		dB	Low gain mode
Noise figure	NF_{HG}		1.0		dB	High gain mode
	NF_{MG}		2.3		dB	Mid gain mode
	NF_{LG}		7.8		dB	Low gain mode
Input return loss ¹⁾	S_{11HG}		-15		dB	50 Ω , high gain mode
	S_{11MG}		-12		dB	50 Ω , mid gain mode
	S_{11LG}		-11		dB	50 Ω , low gain mode
Output return loss ¹⁾	S_{22HG}		-19		dB	50 Ω , high gain mode
	S_{22MG}		-18		dB	50 Ω , mid gain mode
	S_{22LG}		-18		dB	50 Ω , low gain mode
Stability factor ²⁾	k		>2.6			DC to 10 GHz; all gain modes
Input compression point ¹⁾	IP_{1dBHG}		-13		dBm	High gain mode
	IP_{1dBMG}		-13		dBm	Mid gain mode
	$IP_{1dB LG}$		-7		dBm	Low gain mode
Inband IIP3 ¹⁾ $f_1 - f_2 = 1\text{ MHz}$ $P_{f1} = P_{f2} = -26\text{ dBm}$	$IIP3_{HG}$		-5		dBm	High gain mode
	$IIP3_{MG}$		-6			Mid gain mode
	$IIP3_{LG}$		2			Low gain mode

1) Verified by random sampling; not 100% RF tested

2) Not tested in production; guaranteed by device design

Measured RF Characteristics Mid Band
2.10.2 Measured RF Characteristics UMTS Band IV
Table 11 Typical Characteristics 2100 MHz Band, $T_A = 25\text{ °C}$, $V_{CC} = 2.8\text{ V}$, $R_{REF} = 8.2\text{ k}\Omega$

Parameter	Symbol	Values			Unit	Note / Test Condition
		Min.	Typ.	Max.		
Pass band range		2110		2155	MHz	
Current consumption	I_{CCHG}		5.30		mA	High gain mode
	I_{CCMG}		5.30		mA	Mid gain mode
	I_{CCLG}		0.85		mA	Low gain mode
Gain	S_{21HG}		15.3		dB	High gain mode
	S_{21MG}		2.3		dB	Mid gain mode
	S_{21LG}		-7.5		dB	Low gain mode
Reverse Isolation ¹⁾	S_{12HG}		-34		dB	High gain mode
	S_{12MG}		-35		dB	Mid gain mode
	S_{12LG}		-8		dB	Low gain mode
Noise figure	NF_{HG}		1.1		dB	High gain mode
	NF_{MG}		2.7		dB	Mid gain mode
	NF_{LG}		7.5		dB	Low gain mode
Input return loss ¹⁾	S_{11HG}		-19		dB	50 Ω , high gain mode
	S_{11MG}		-14		dB	50 Ω , mid gain mode
	S_{11LG}		-12		dB	50 Ω , low gain mode
Output return loss ¹⁾	S_{22HG}		-18		dB	50 Ω , high gain mode
	S_{22MG}		-17		dB	50 Ω , mid gain mode
	S_{22LG}		-15		dB	50 Ω , low gain mode
Stability factor ²⁾	k		>2.6			DC to 10 GHz; all gain modes
Input compression point ¹⁾	IP_{1dBHG}		-12		dBm	High gain mode
	IP_{1dBMG}		-12		dBm	Mid gain mode
	$IP_{1dB LG}$		-6		dBm	Low gain mode
Inband IIP3 ¹⁾ $f_1 - f_2 = 1\text{ MHz}$ $P_{f1} = P_{f2} = -26\text{ dBm}$	$IIP3_{HG}$		-5		dBm	High gain mode
	$IIP3_{MG}$		-6			Mid gain mode
	$IIP3_{LG}$		2			Low gain mode

1) Verified by random sampling; not 100% RF tested

2) Not tested in production; guaranteed by device design

2.11 Measured RF Characteristics High Band

2.11.1 Measured RF Characteristics UMTS Band I

Table 12 Typical Characteristics 2100 MHz Band, $T_A = 25\text{ }^\circ\text{C}$, $V_{CC} = 2.8\text{ V}$, $R_{REF} = 8.2\text{ k}\Omega$

Parameter	Symbol	Values			Unit	Note / Test Condition
		Min.	Typ.	Max.		
Pass band range		2110		2170	MHz	
Current consumption	I_{CCHG}		5.30		mA	High gain mode
	I_{CCMG}		5.30		mA	Mid gain mode
	I_{CCLG}		0.85		mA	Low gain mode
Gain	S_{21HG}		16.2		dB	High gain mode
	S_{21MG}		2.3		dB	Mid gain mode
	S_{21LG}		-8.0		dB	Low gain mode
Reverse Isolation ¹⁾	S_{12HG}		-35		dB	High gain mode
	S_{12MG}		-36		dB	Mid gain mode
	S_{12LG}		-8		dB	Low gain mode
Noise figure	NF_{HG}		1.0		dB	High gain mode
	NF_{MG}		2.6		dB	Mid gain mode
	NF_{LG}		7.9		dB	Low gain mode
Input return loss ¹⁾	S_{11HG}		-13		dB	50 Ω , high gain mode
	S_{11MG}		-12		dB	50 Ω , mid gain mode
	S_{11LG}		-10		dB	50 Ω , low gain mode
Output return loss ¹⁾	S_{22HG}		-19		dB	50 Ω , high gain mode
	S_{22MG}		-24		dB	50 Ω , mid gain mode
	S_{22LG}		-14		dB	50 Ω , low gain mode
Stability factor ²⁾	k		>2.2			DC to 10 GHz; all gain modes
Input compression point ¹⁾	IP_{1dBHG}		-13		dBm	High gain mode
	IP_{1dBMG}		-13		dBm	Mid gain mode
	IP_{1dBLG}		-7		dBm	Low gain mode
Inband IIP3 ¹⁾ $f_1 - f_2 = 1\text{ MHz}$ $P_{f1} = P_{f2} = -27\text{ dBm}$	$IIP3_{HG}$		-5		dBm	High gain mode
	$IIP3_{MG}$		-5			Mid gain mode
	$IIP3_{LG}$		2			Low gain mode

1) Verified by random sampling; not 100% RF tested

2) Not tested in production; guaranteed by device design

Measured Performance Low Band High Gain Mode vs. Frequency

2.12 Measured Performance Low Band High Gain Mode vs. Frequency

$T_A = 25\text{ }^\circ\text{C}$, $V_{CC} = 2.8\text{ V}$, $V_{GS1} = 2.8\text{ V}$, $V_{GS2} = 0\text{ V}$, $V_{EN1} = 0\text{ V}$, $V_{EN2} = 2.8\text{ V}$, $R_{REF} = 8.2\text{ k}\Omega$

Power Gain $|S_{21}| = f(f)$

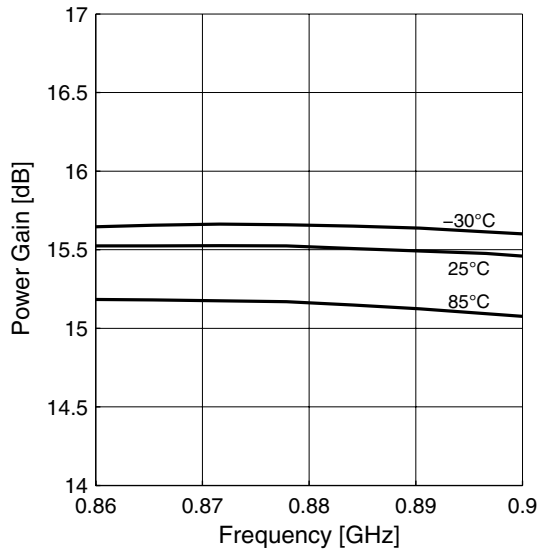

Power Gain Wideband $|S_{21}| = f(f)$

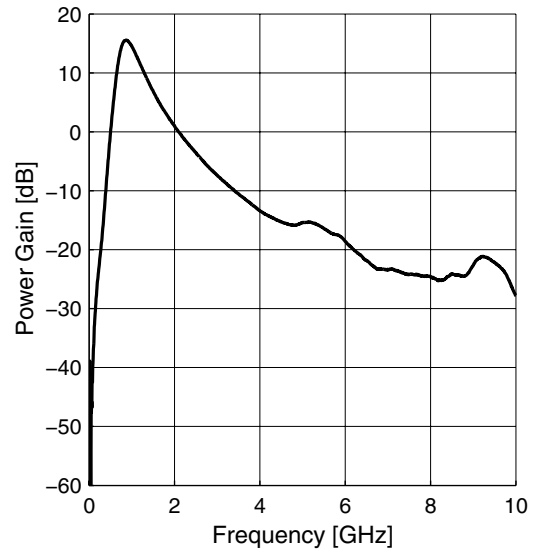

Matching $|S_{11}| = f(f)$, $|S_{22}| = f(f)$

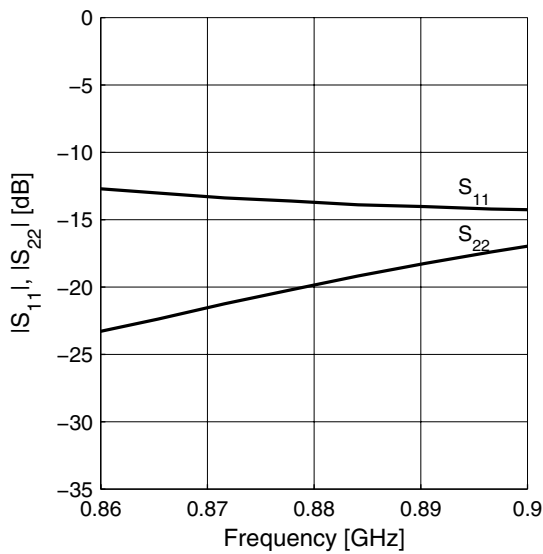

Reverse Isolation $|S_{12}| = f(f)$

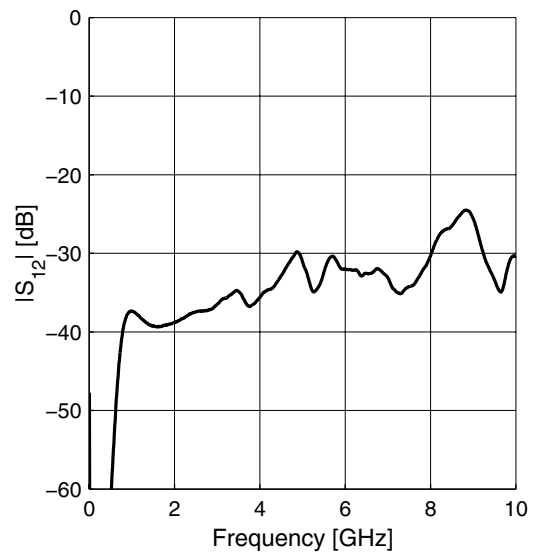

Measured Performance Low Band High Gain Mode vs. Temperature

Noise Figure $NF = f(f)$

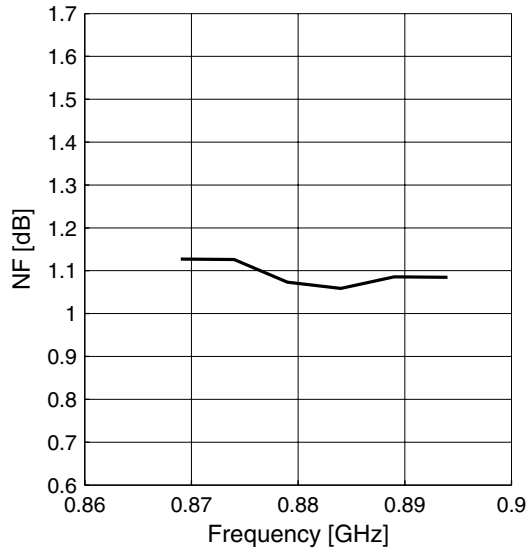

Input Compression $P_{1dB} = f(f)$

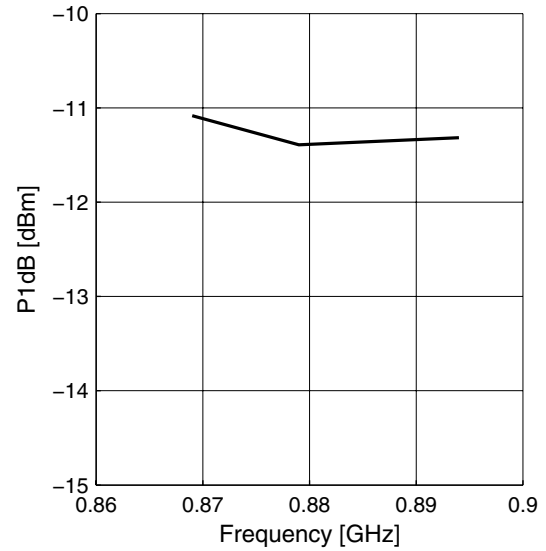

2.13 Measured Performance Low Band High Gain Mode vs. Temperature

$V_{CC} = 2.8 \text{ V}$, $V_{GS1} = 2.8 \text{ V}$, $V_{GS2} = 0 \text{ V}$, $V_{EN1} = 0 \text{ V}$, $V_{EN2} = 2.8 \text{ V}$, $R_{REF} = 8.2 \text{ k}\Omega$

Power Gain $|S_{21}| = f(T_A)$

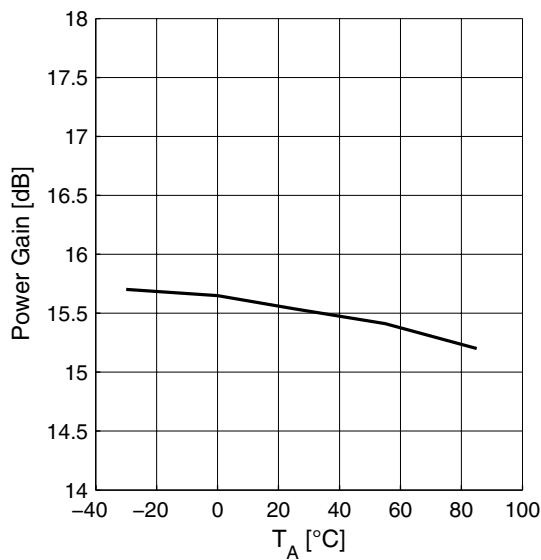

Supply Current $I_{CC} = f(T_A)$

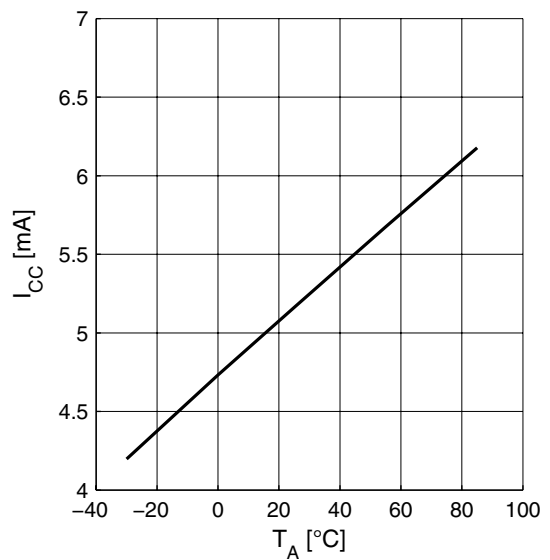

Measured Performance Low Band Mid Gain Mode vs. Frequency

Noise Figure $NF = f(T_A)$

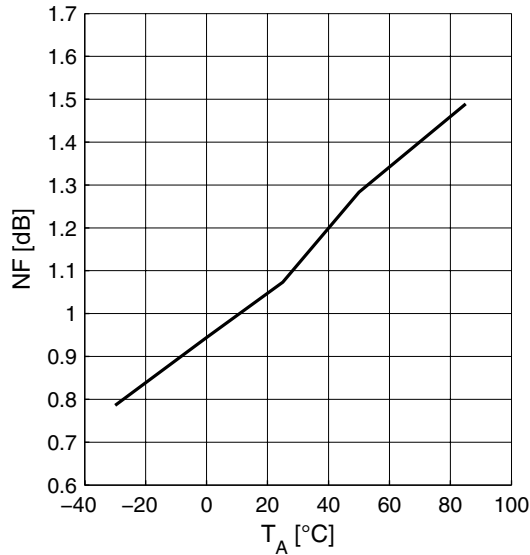

Input Compression $P_{1dB} = f(T_A)$

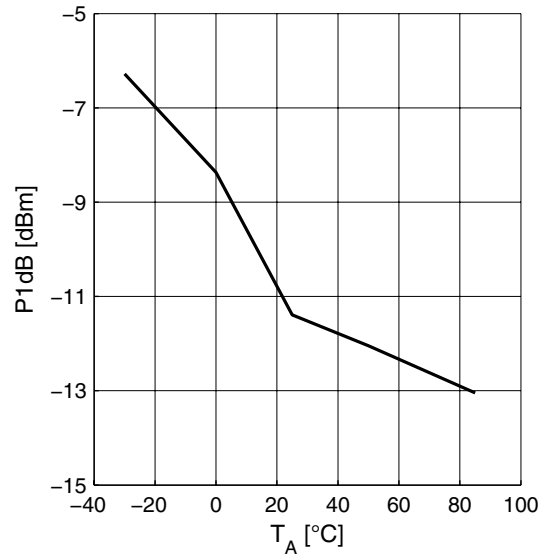

2.14 Measured Performance Low Band Mid Gain Mode vs. Frequency

$T_A = 25^\circ\text{C}$, $V_{CC} = 2.8\text{ V}$, $V_{GS1} = 2.8\text{ V}$, $V_{GS2} = 2.8\text{ V}$, $V_{EN1} = 0\text{ V}$, $V_{EN2} = 2.8\text{ V}$, $R_{REF} = 8.2\text{ k}\Omega$

Power Gain $|S_{21}| = f(f)$

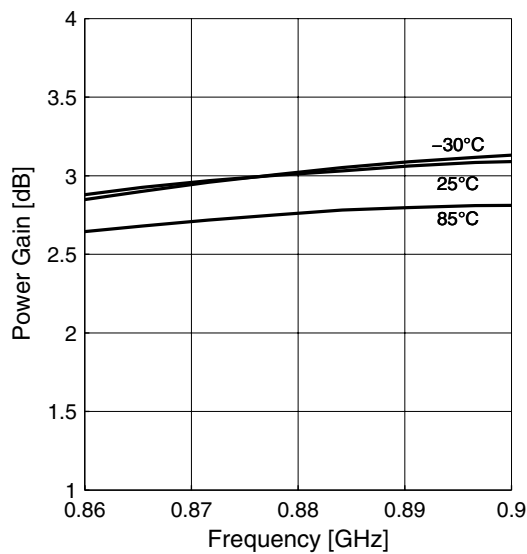

Power Gain Wideband $|S_{21}| = f(f)$

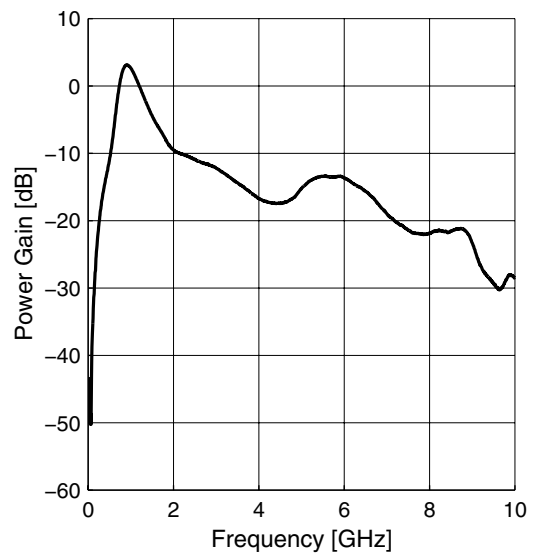

Measured Performance Low Band Mid Gain Mode vs. Frequency

Matching $|S_{11}| = f(f)$, $|S_{22}| = f(f)$

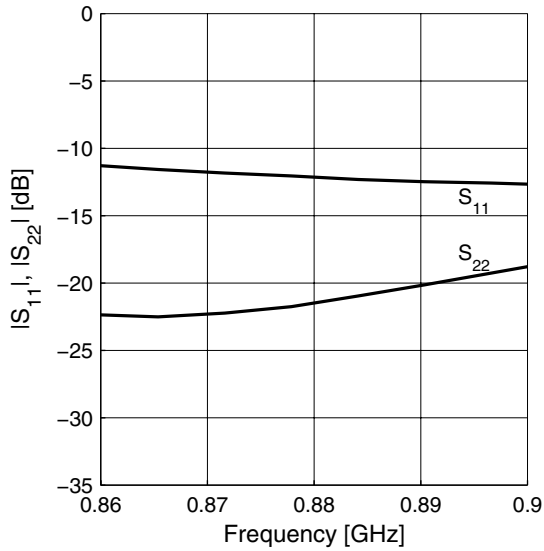

Reverse Isolation $|S_{12}| = f(f)$

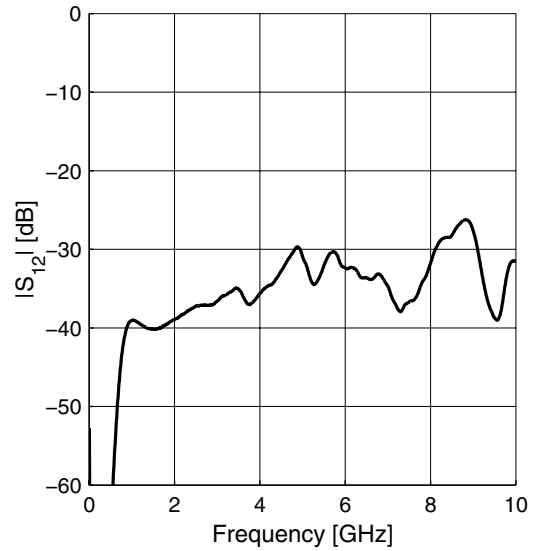

Noise Figure $NF = f(f)$

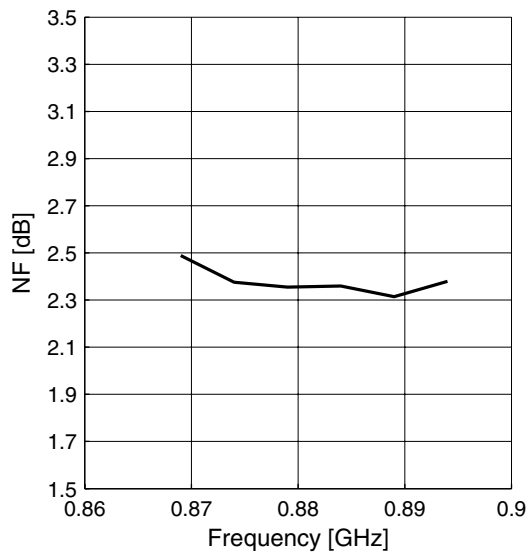

Input Compression $P_{1dB} = f(f)$

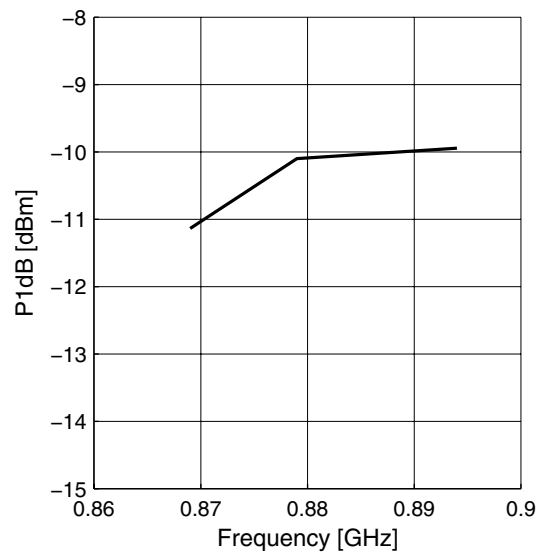

Measured Performance Low Band Mid Gain Mode vs. Temperature

2.15 Measured Performance Low Band Mid Gain Mode vs. Temperature

$V_{CC} = 2.8 \text{ V}$, $V_{GS1} = 2.8 \text{ V}$, $V_{GS2} = 2.8 \text{ V}$, $V_{EN1} = 0 \text{ V}$, $V_{EN2} = 2.8 \text{ V}$, $R_{REF} = 8.2 \text{ k}\Omega$

Power Gain $|S_{21}| = f(T_A)$

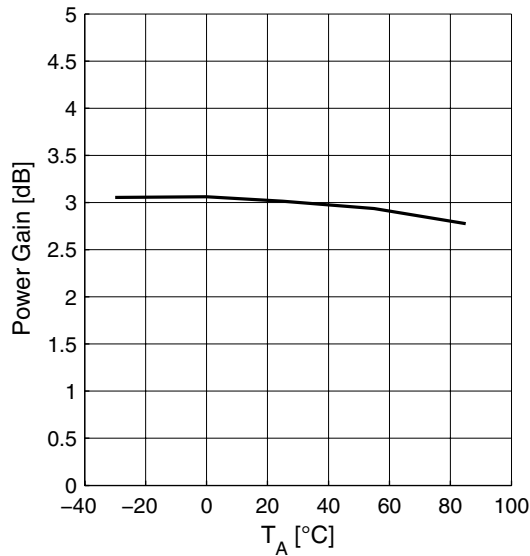

Supply Current $I_{CC} = f(T_A)$

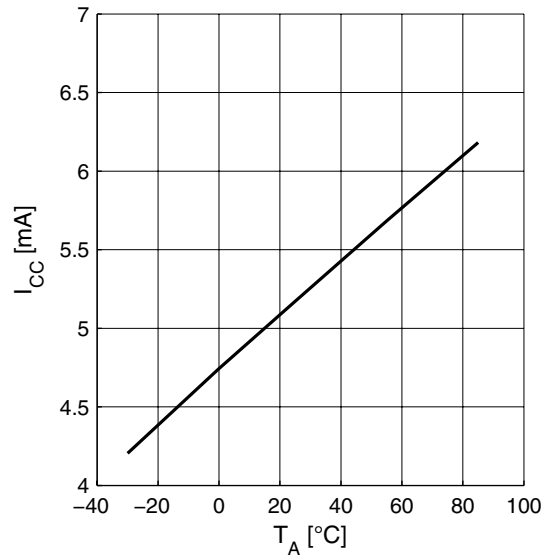

Noise Figure $NF = f(T_A)$

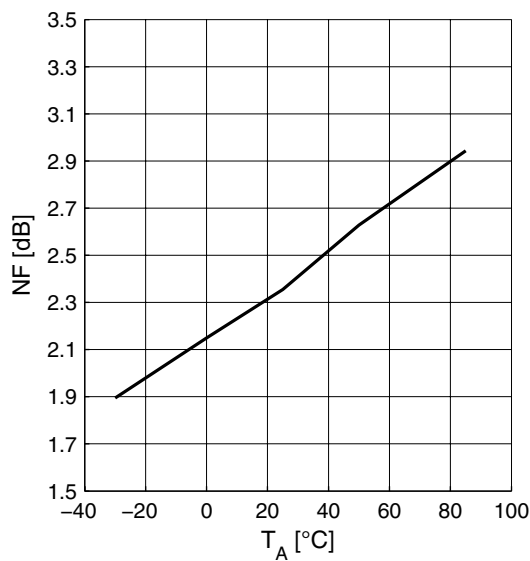

Input Compression $P_{1dB} = f(T_A)$

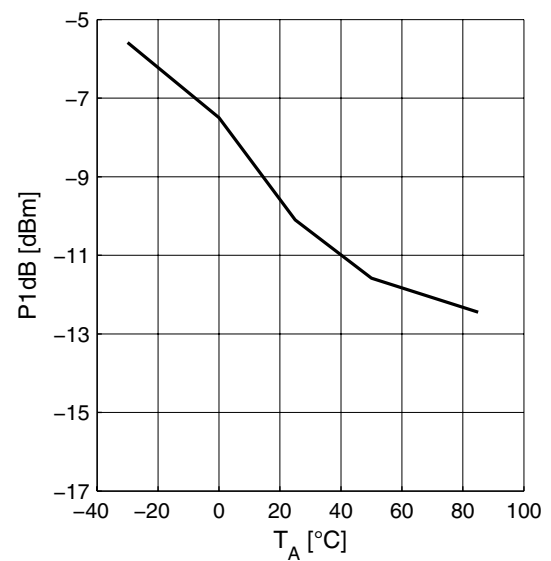

Measured Performance Low Band Low Gain Mode vs. Frequency

2.16 Measured Performance Low Band Low Gain Mode vs. Frequency

$T_A = 25\text{ }^\circ\text{C}$, $V_{CC} = 2.8\text{ V}$, $V_{GS1} = 0\text{ V}$, $V_{GS2} = 0\text{ V}$, $V_{EN1} = 0\text{ V}$, $V_{EN2} = 2.8\text{ V}$, $R_{REF} = 8.2\text{ k}\Omega$

Power Gain $|S_{21}| = f(f)$

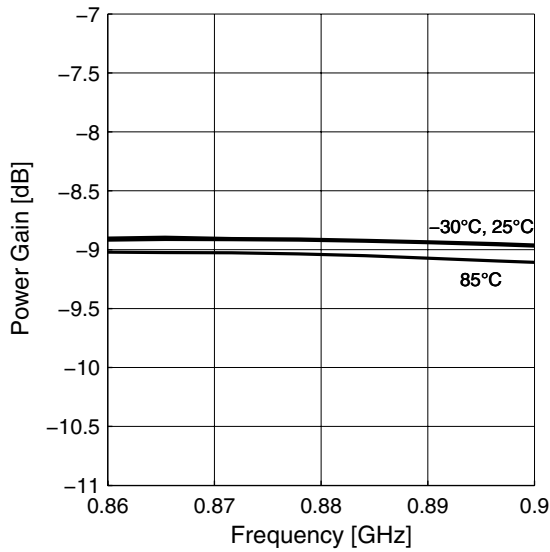

Power Gain Wideband $|S_{21}| = f(f)$

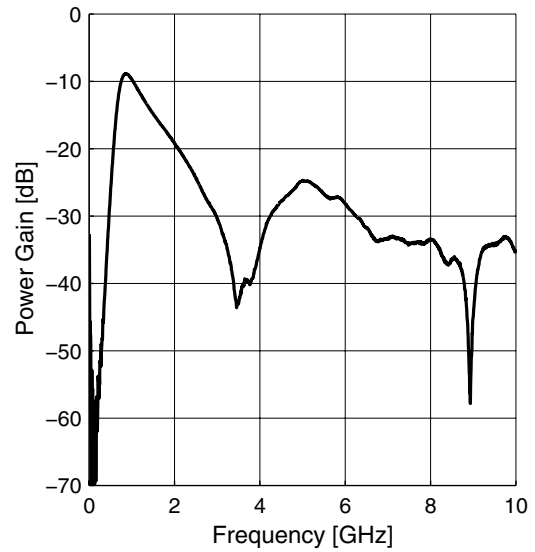

Matching $|S_{11}| = f(f)$, $|S_{22}| = f(f)$

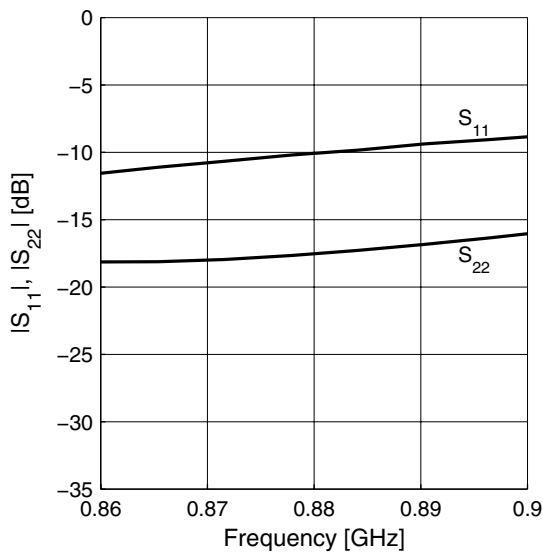

Reverse Isolation $|S_{12}| = f(f)$

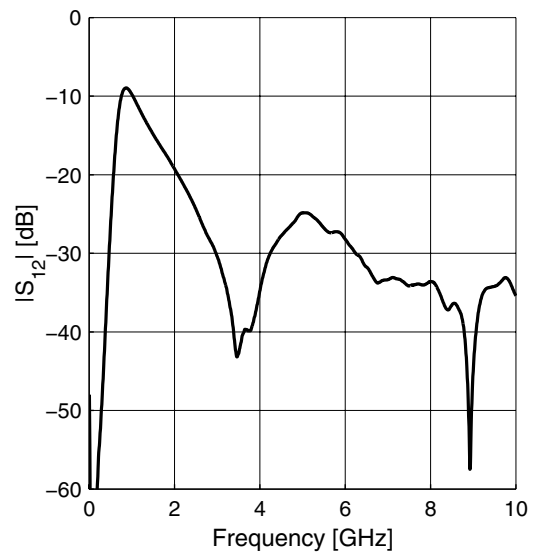

Measured Performance Low Band Low Gain Mode vs. Temperature

Noise Figure $NF = f(f)$

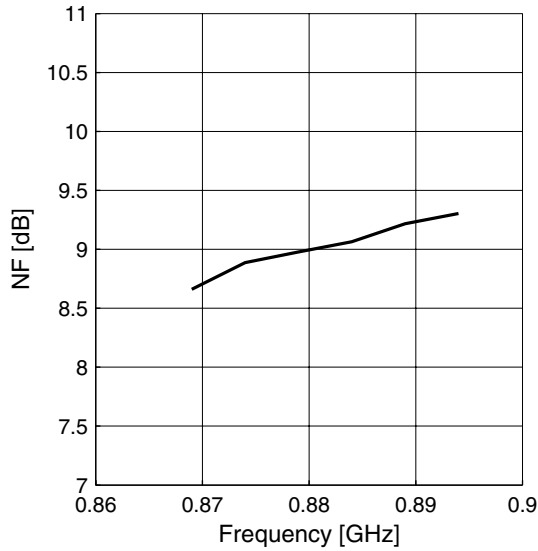

Input Compression $P_{1dB} = f(f)$

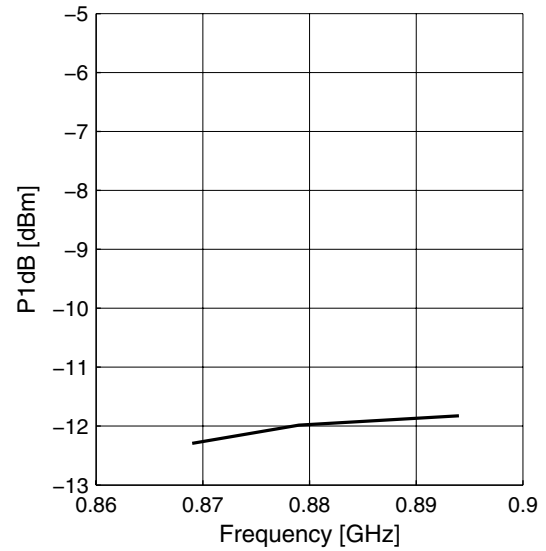

2.17 Measured Performance Low Band Low Gain Mode vs. Temperature

$V_{CC} = 2.8 \text{ V}$, $V_{GS1} = 0 \text{ V}$, $V_{GS2} = 0 \text{ V}$, $V_{EN1} = 0 \text{ V}$, $V_{EN2} = 2.8 \text{ V}$, $R_{REF} = 8.2 \text{ k}\Omega$

Power Gain $|S_{21}| = f(T_A)$

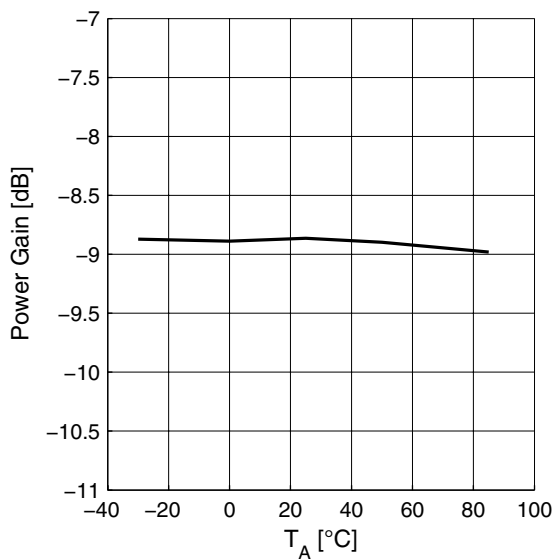

Supply Current $I_{CC} = f(T_A)$

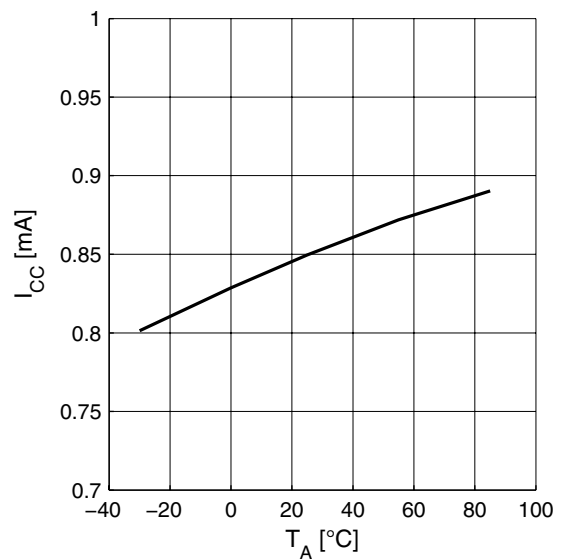

Measured Performance Mid Band High Gain Mode vs. Frequency

Noise Figure $NF = f(T_A)$

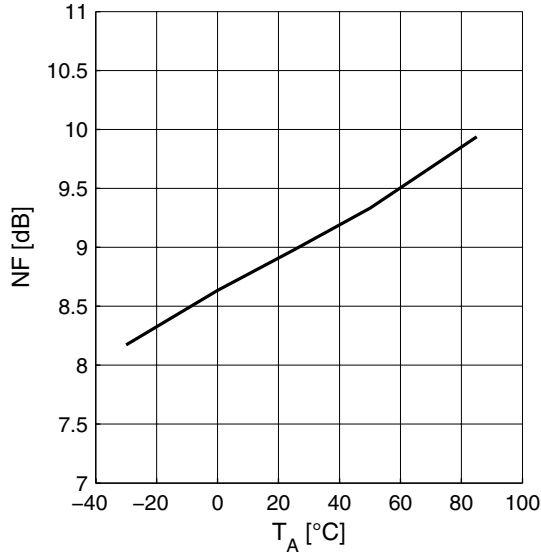

Input Compression $P_{1dB} = f(T_A)$

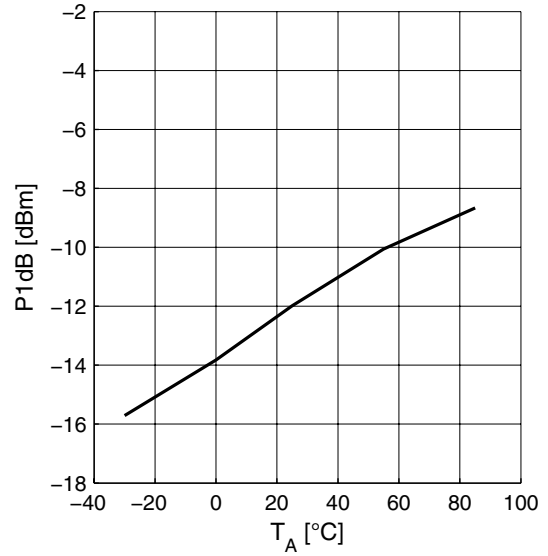

2.18 Measured Performance Mid Band High Gain Mode vs. Frequency

$T_A = 25\text{ °C}$, $V_{CC} = 2.8\text{ V}$, $V_{GS1} = 2.8\text{ V}$, $V_{GS2} = 0\text{ V}$, $V_{EN1} = 2.8\text{ V}$, $V_{EN2} = 0\text{ V}$, $R_{REF} = 8.2\text{ k}\Omega$

Power Gain $|S_{21}| = f(f)$

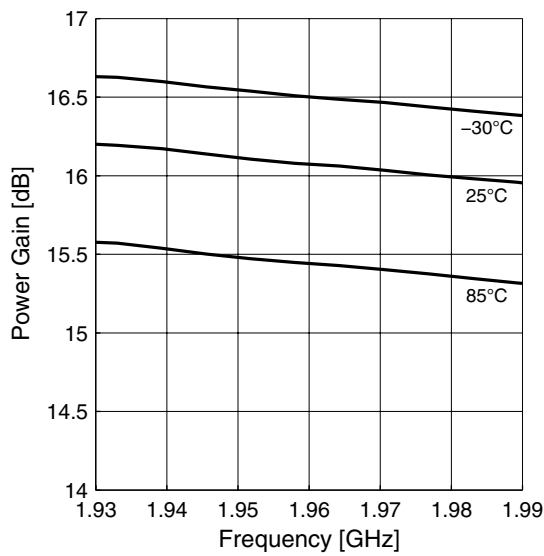

Power Gain Wideband $|S_{21}| = f(f)$

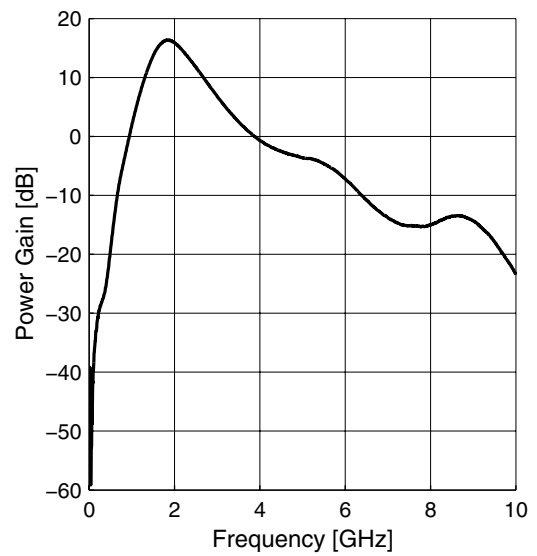

Measured Performance Mid Band High Gain Mode vs. Frequency

Matching $|S_{11}| = f(f)$, $|S_{22}| = f(f)$

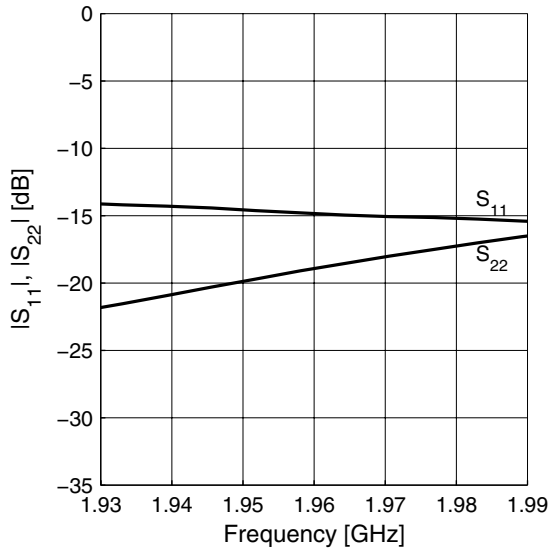

Reverse Isolation $|S_{12}| = f(f)$

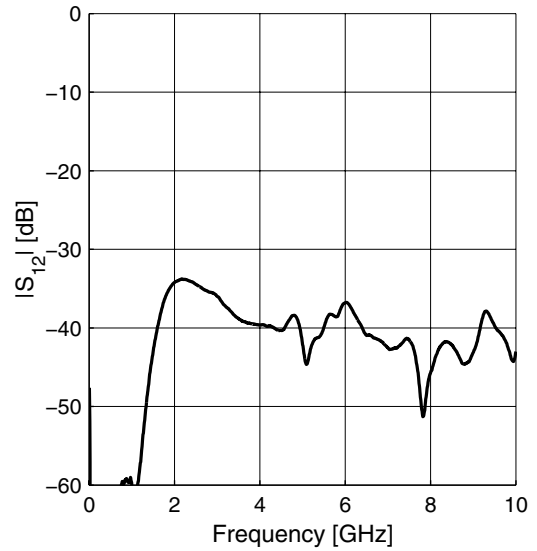

Noise Figure $NF = f(f)$

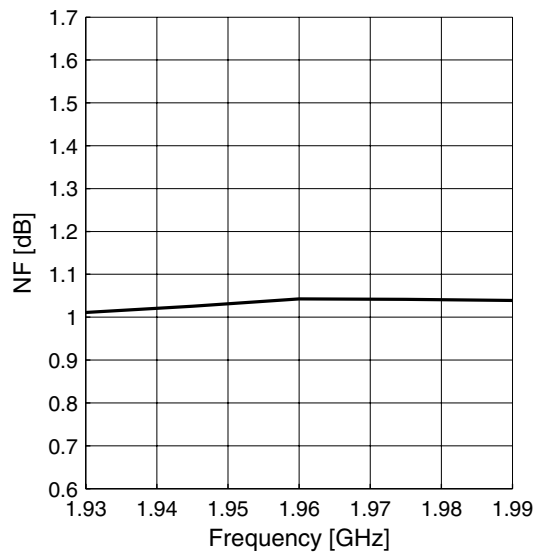

Input Compression $P_{1dB} = f(f)$

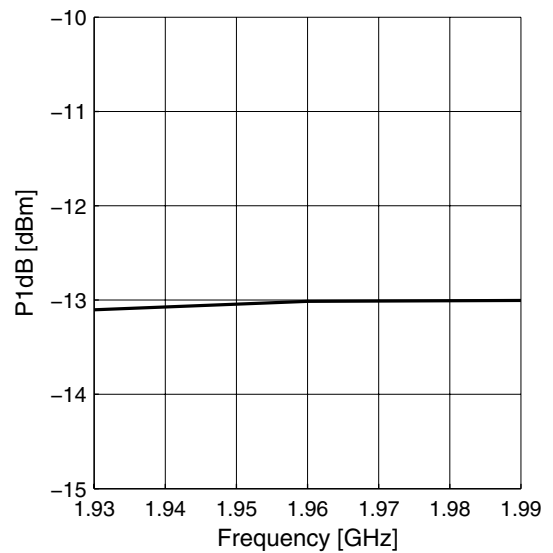

Measured Performance Mid Band High Gain Mode vs. Temperature

2.19 Measured Performance Mid Band High Gain Mode vs. Temperature

$V_{CC} = 2.8\text{ V}$, $V_{GS1} = 2.8\text{ V}$, $V_{GS2} = 0\text{ V}$, $V_{EN1} = 2.8\text{ V}$, $V_{EN2} = 0\text{ V}$, $R_{REF} = 8.2\text{ k}\Omega$

Power Gain $|S_{21}| = f(T_A)$

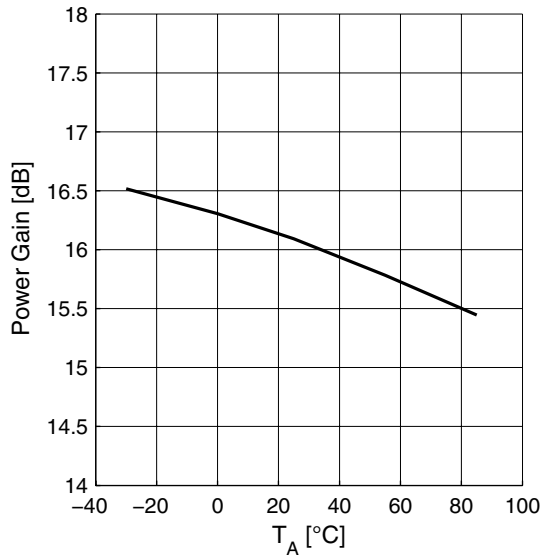

Supply Current $I_{CC} = f(T_A)$

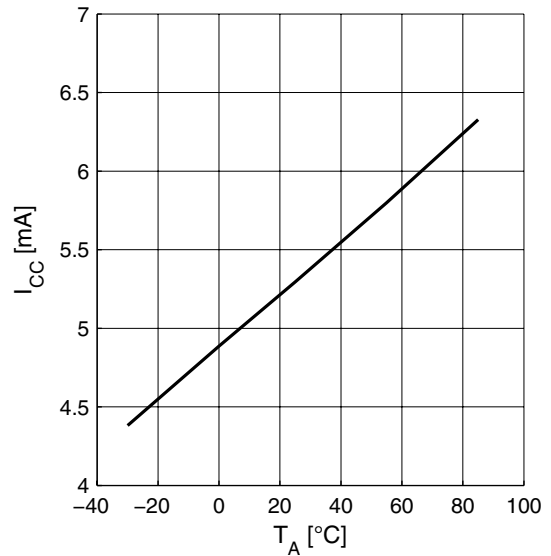

Noise Figure $NF = f(T_A)$

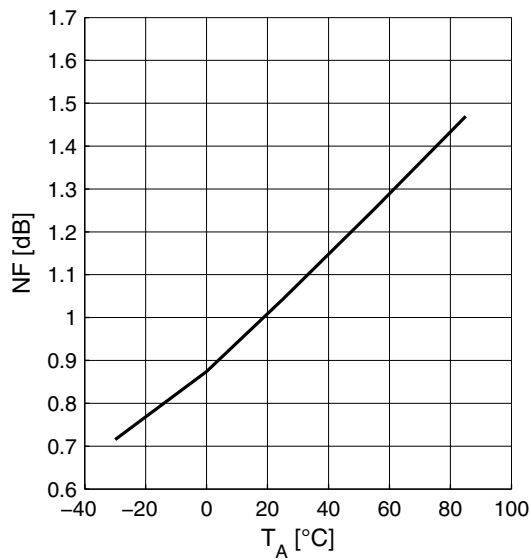

Input Compression $P_{1dB} = f(T_A)$

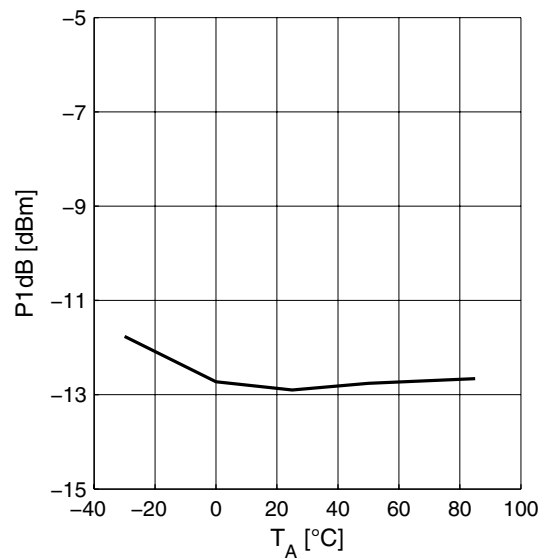

Measured Performance Mid Band Mid Gain Mode vs. Frequency

2.20 Measured Performance Mid Band Mid Gain Mode vs. Frequency

$T_A = 25\text{ }^\circ\text{C}$, $V_{CC} = 2.8\text{ V}$, $V_{GS1} = 2.8\text{ V}$, $V_{GS2} = 2.8\text{ V}$, $V_{EN1} = 2.8\text{ V}$, $V_{EN2} = 0\text{ V}$, $R_{REF} = 8.2\text{ k}\Omega$

Power Gain $|S_{21}| = f(f)$

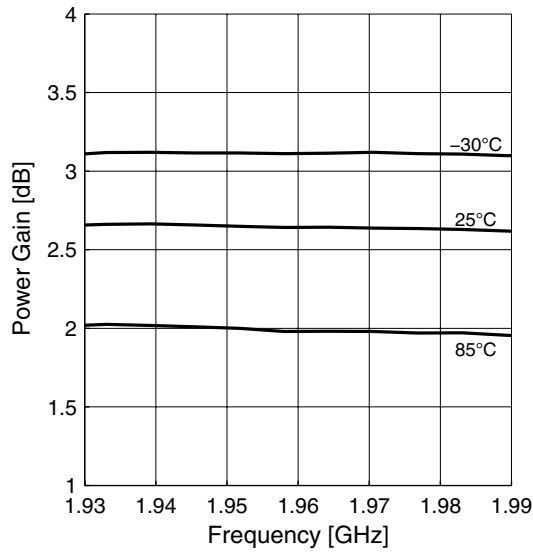

Power Gain Wideband $|S_{21}| = f(f)$

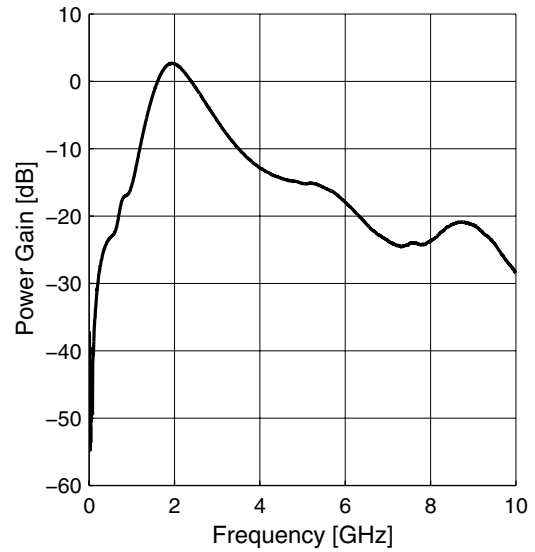

Matching $|S_{11}| = f(f)$, $|S_{22}| = f(f)$

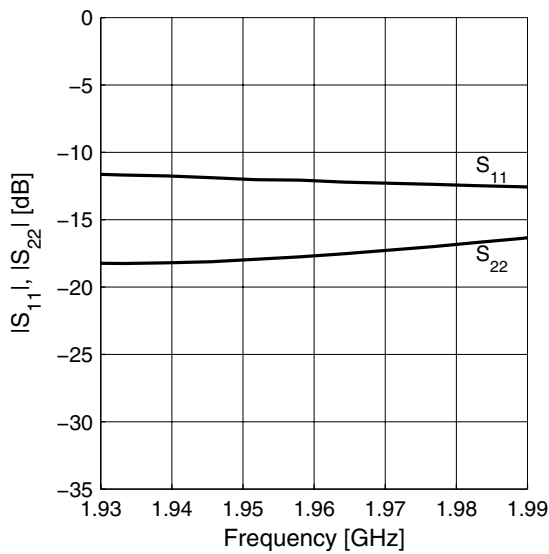

Reverse Isolation $|S_{12}| = f(f)$

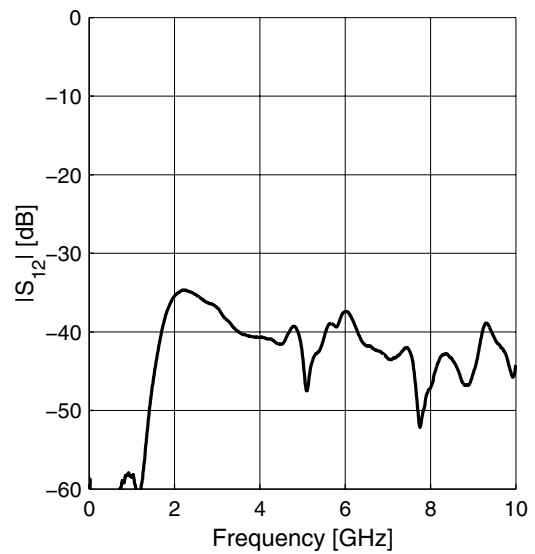

Measured Performance Mid Band Mid Gain Mode vs. Temperature

Noise Figure $NF = f(f)$

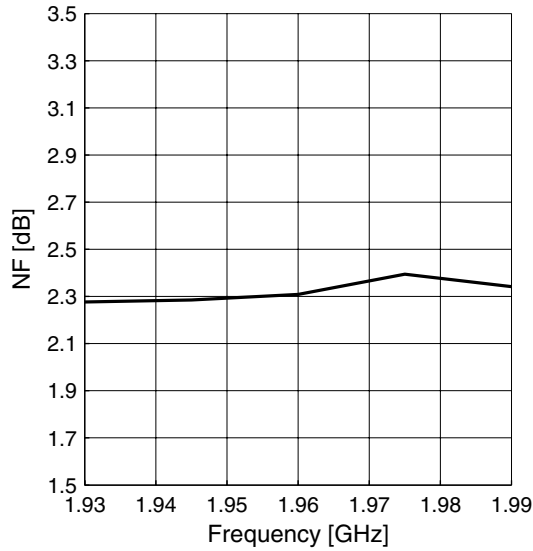

Input Compression $P_{1dB} = f(f)$

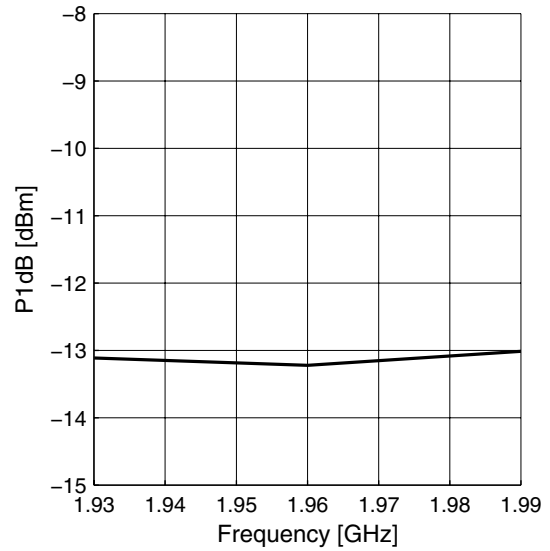

2.21 Measured Performance Mid Band Mid Gain Mode vs. Temperature

$V_{CC} = 2.8 \text{ V}$, $V_{GS1} = 2.8 \text{ V}$, $V_{GS2} = 2.8 \text{ V}$, $V_{EN1} = 2.8 \text{ V}$, $V_{EN2} = 0 \text{ V}$, $R_{REF} = 8.2 \text{ k}\Omega$

Power Gain $|S_{21}| = f(T_A)$

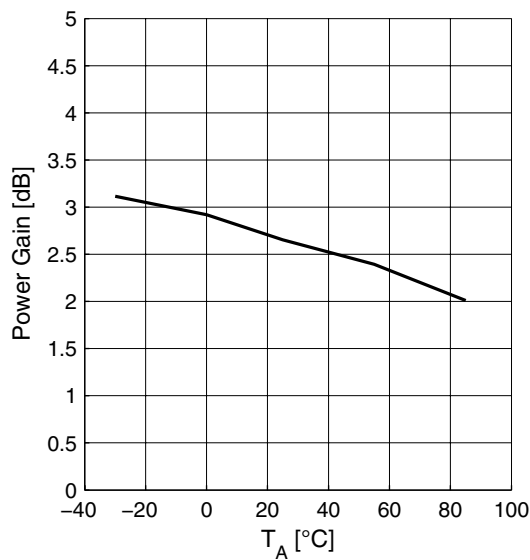

Supply Current $I_{CC} = f(T_A)$

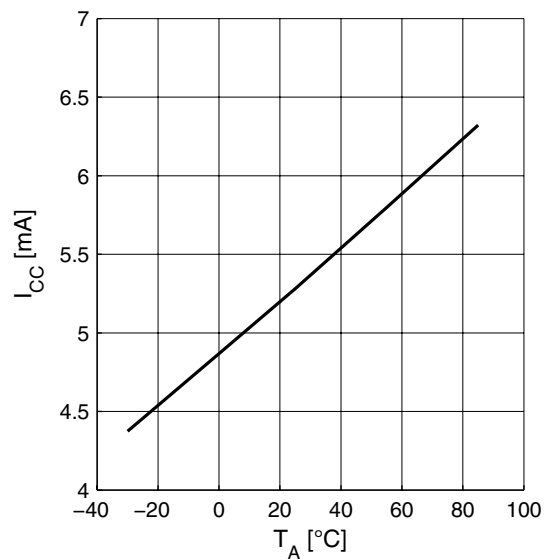

Measured Performance Mid Band Low Gain Mode vs. Frequency

Noise Figure $NF = f(T_A)$

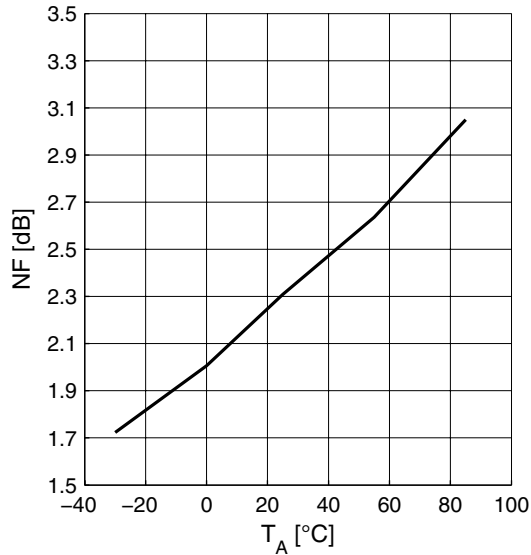

Input Compression $P_{1dB} = f(T_A)$

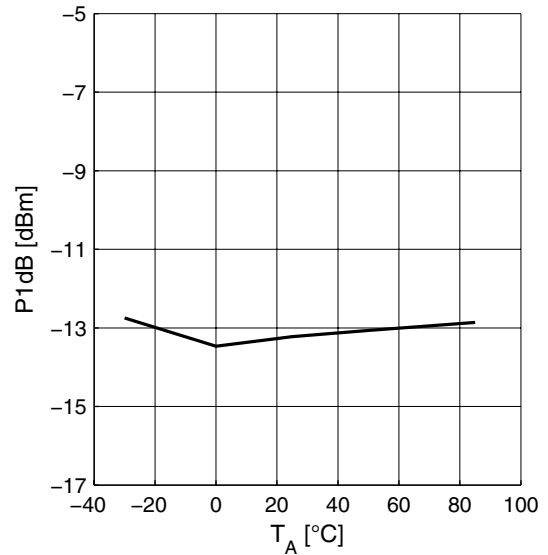

2.22 Measured Performance Mid Band Low Gain Mode vs. Frequency

$T_A = 25^\circ\text{C}$, $V_{CC} = 2.8\text{ V}$, $V_{GS1} = 0\text{ V}$, $V_{GS2} = 0\text{ V}$, $V_{EN1} = 2.8\text{ V}$, $V_{EN2} = 0\text{ V}$, $R_{REF} = 8.2\text{ k}\Omega$

Power Gain $|S_{21}| = f(f)$

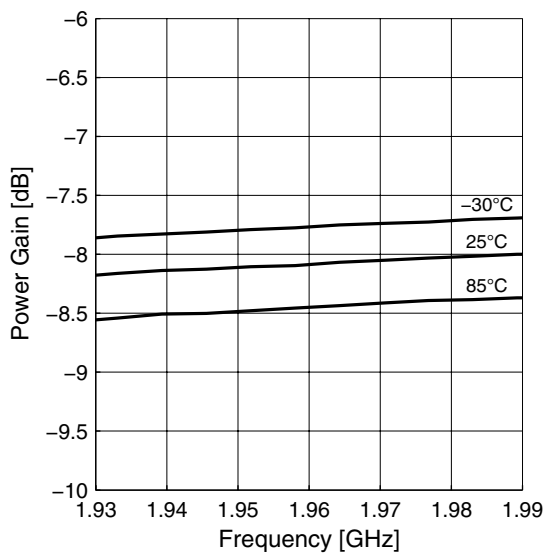

Power Gain Wideband $|S_{21}| = f(f)$

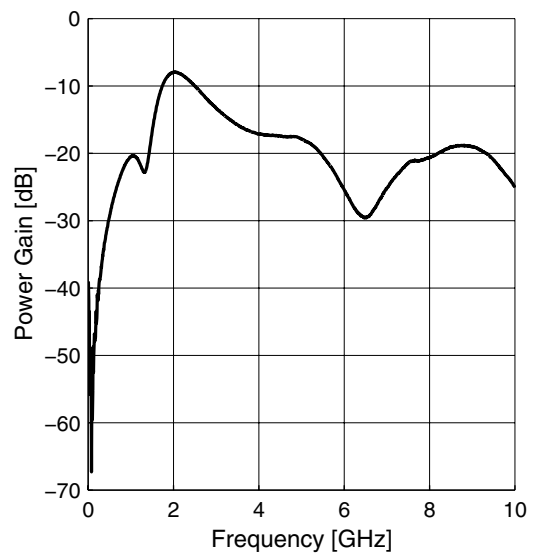

Measured Performance Mid Band Low Gain Mode vs. Frequency

Matching $|S_{11}| = f(f)$, $|S_{22}| = f(f)$

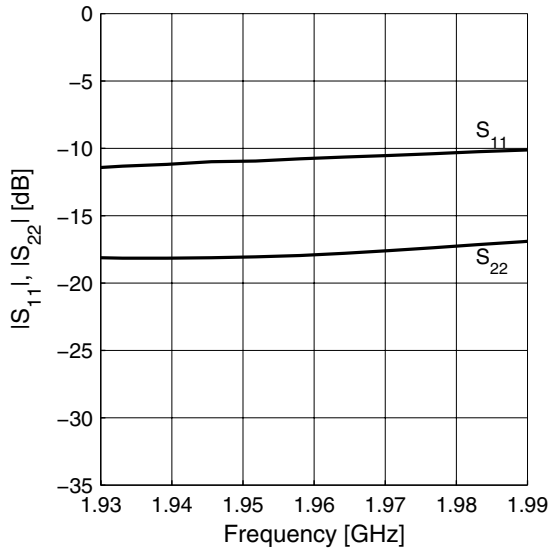

Reverse Isolation $|S_{12}| = f(f)$

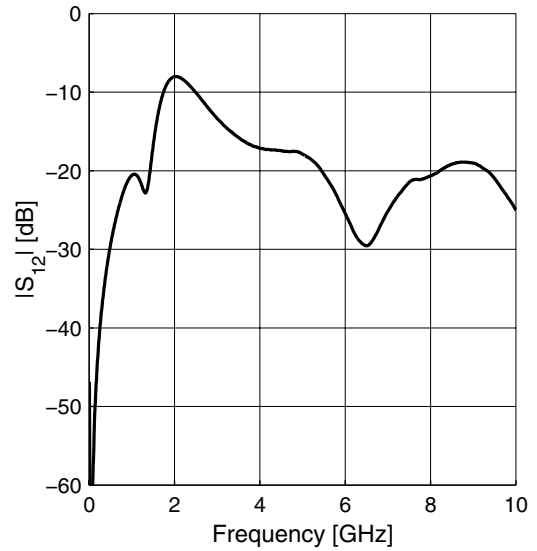

Noise Figure $NF = f(f)$

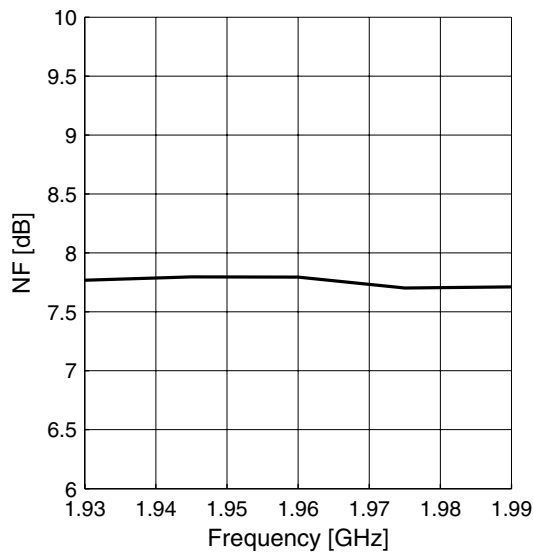

Input Compression $P_{1dB} = f(f)$

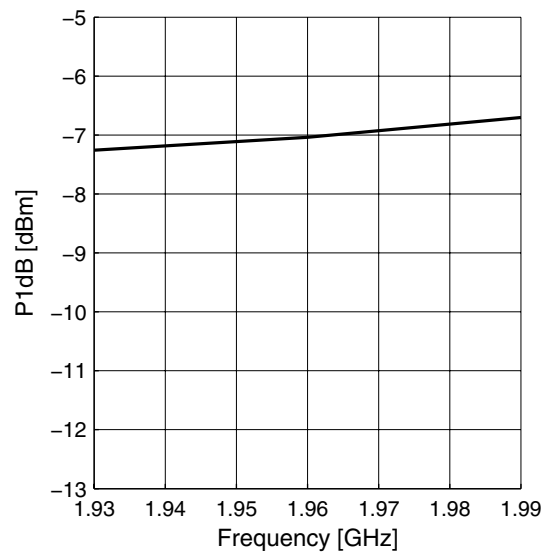

Measured Performance Mid Band Low Gain Mode vs. Temperature

2.23 Measured Performance Mid Band Low Gain Mode vs. Temperature

$V_{CC} = 2.8\text{ V}$, $V_{GS1} = 0\text{ V}$, $V_{GS2} = 0\text{ V}$, $V_{EN1} = 2.8\text{ V}$, $V_{EN2} = 0\text{ V}$, $R_{REF} = 8.2\text{ k}\Omega$

Power Gain $|S_{21}| = f(T_A)$

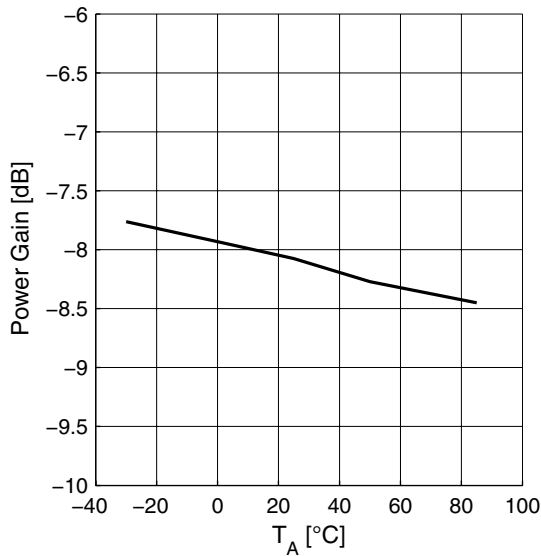

Supply Current $I_{CC} = f(T_A)$

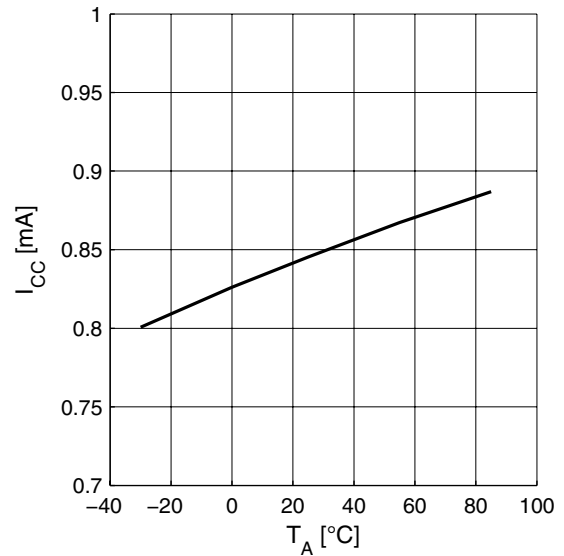

Noise Figure $NF = f(T_A)$

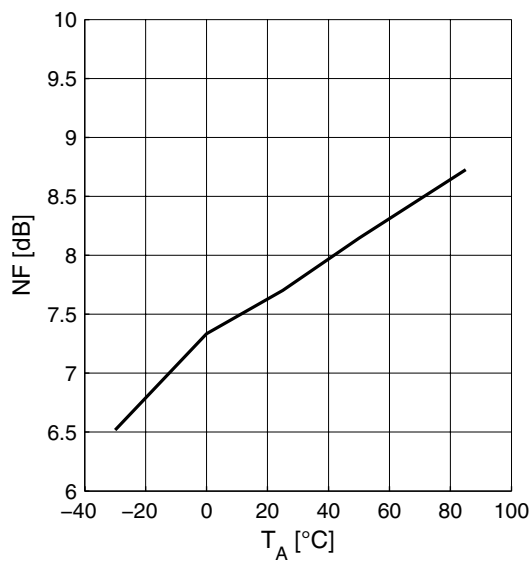

Input Compression $P_{1dB} = f(T_A)$

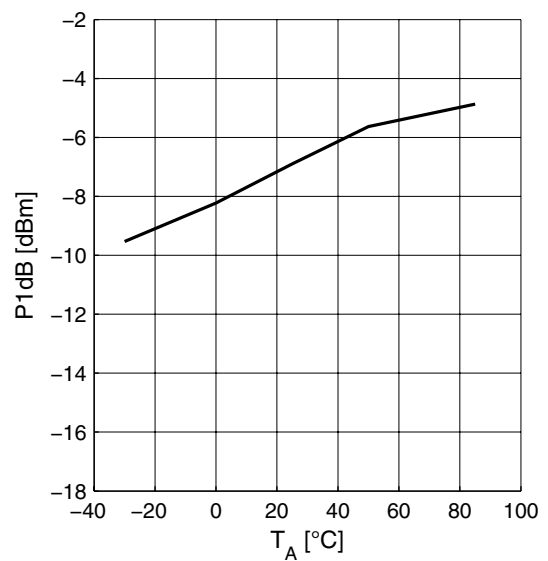

Measured Performance High Band High Gain Mode vs. Frequency

2.24 Measured Performance High Band High Gain Mode vs. Frequency

$T_A = 25\text{ }^\circ\text{C}$, $V_{CC} = 2.8\text{ V}$, $V_{GS1} = 2.8\text{ V}$, $V_{GS2} = 0\text{ V}$, $V_{EN1} = 2.8\text{ V}$, $V_{EN2} = 2.8\text{ V}$, $R_{REF} = 8.2\text{ k}\Omega$

Power Gain $|S_{21}| = f(f)$

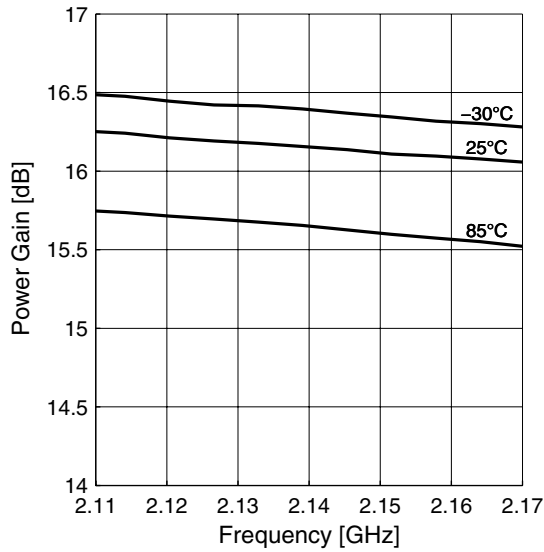

Power Gain Wideband $|S_{21}| = f(f)$

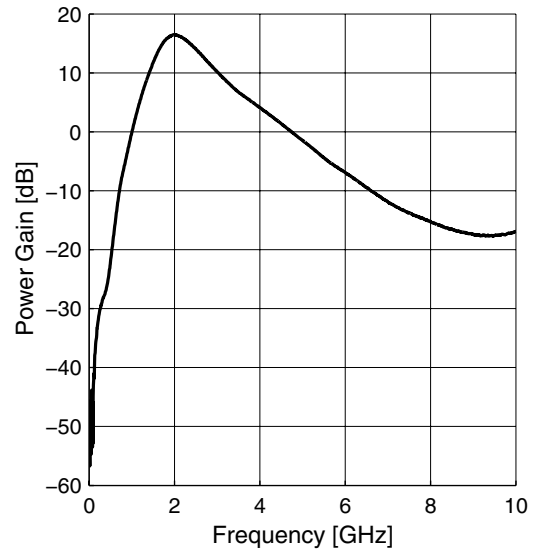

Matching $|S_{11}| = f(f)$, $|S_{22}| = f(f)$

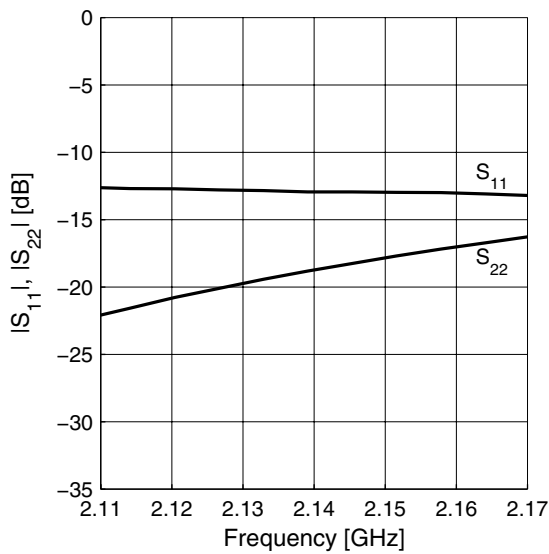

Reverse Isolation $|S_{12}| = f(f)$

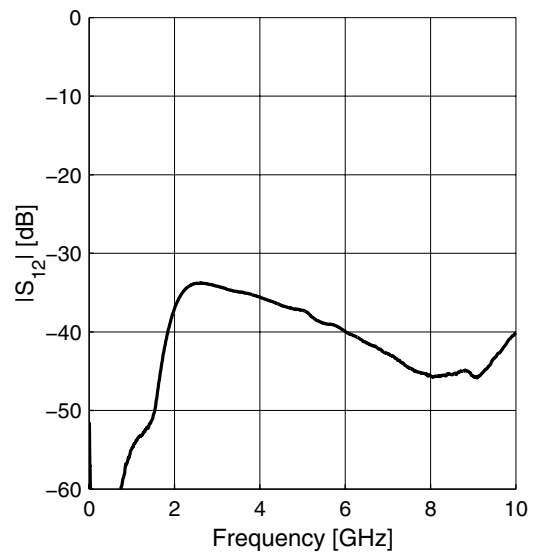

Measured Performance High Band High Gain Mode vs. Temperature

Noise Figure $NF = f(f)$

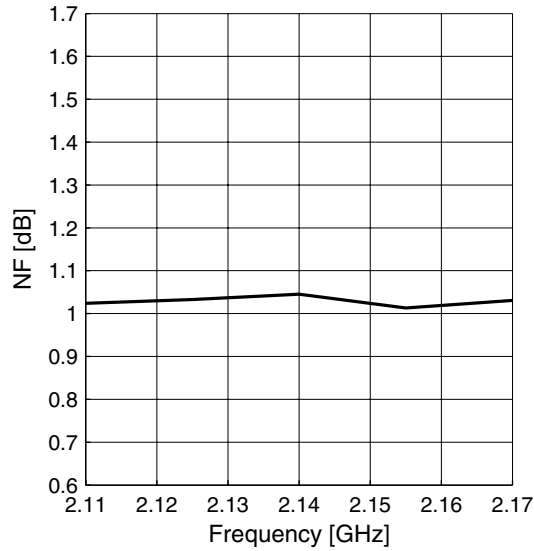

Input Compression $P_{1dB} = f(f)$

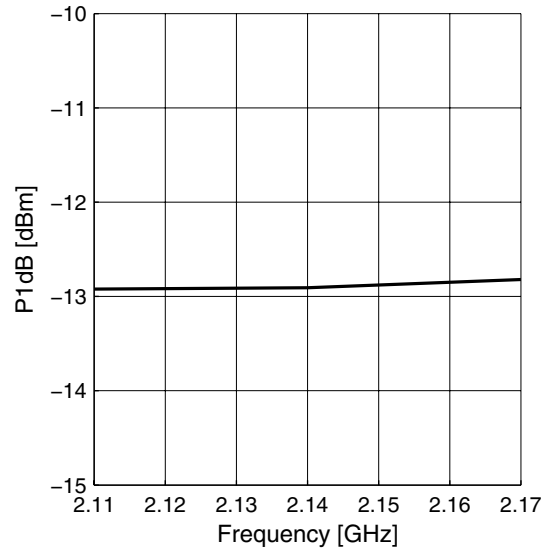

2.25 Measured Performance High Band High Gain Mode vs. Temperature

$V_{CC} = 2.8 \text{ V}$, $V_{GS1} = 2.8 \text{ V}$, $V_{GS2} = 0 \text{ V}$, $V_{EN1} = 2.8 \text{ V}$, $V_{EN2} = 2.8 \text{ V}$, $R_{REF} = 8.2 \text{ k}\Omega$

Power Gain $|S_{21}| = f(T_A)$

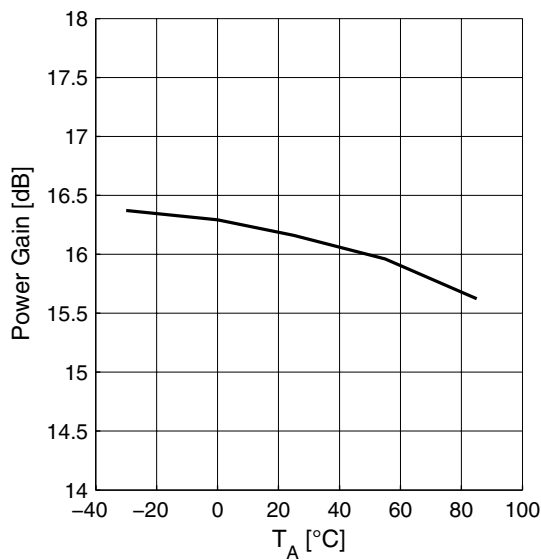

Supply Current $I_{CC} = f(T_A)$

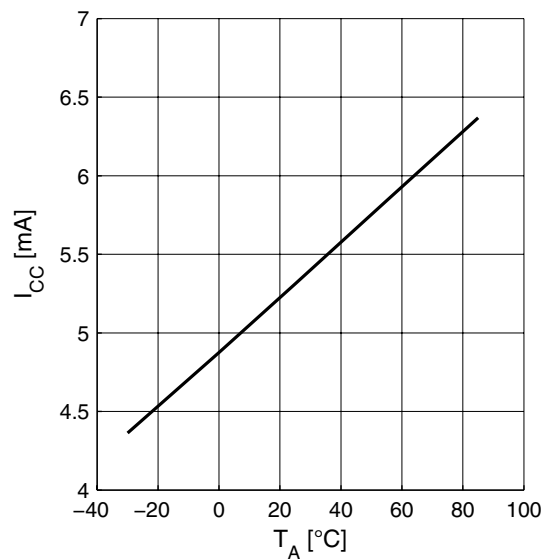

Measured Performance High Band Mid Gain Mode vs. Frequency

Noise Figure $NF = f(T_A)$

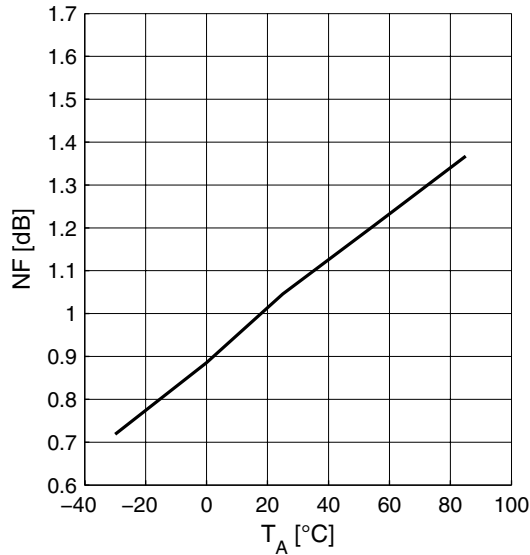

Input Compression $P_{1dB} = f(T_A)$

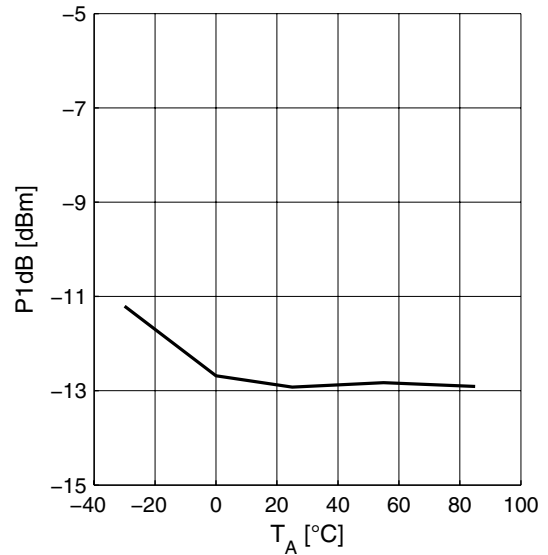

2.26 Measured Performance High Band Mid Gain Mode vs. Frequency

$T_A = 25^\circ\text{C}$, $V_{CC} = 2.8\text{ V}$, $V_{GS1} = 2.8\text{ V}$, $V_{GS2} = 2.8\text{ V}$, $V_{EN1} = 2.8\text{ V}$, $V_{EN2} = 2.8\text{ V}$, $R_{REF} = 8.2\text{ k}\Omega$

Power Gain $|S_{21}| = f(f)$

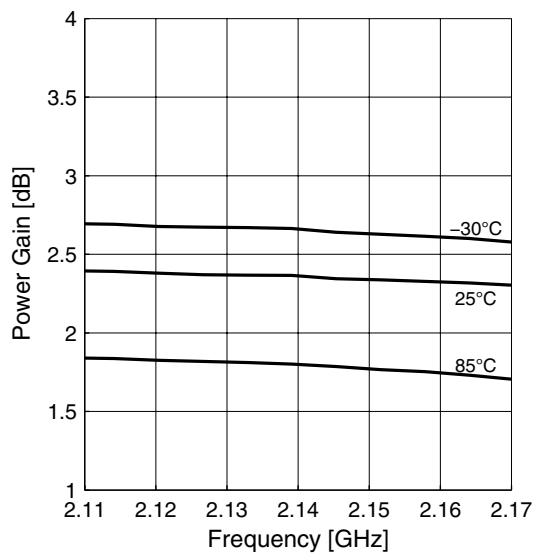

Power Gain Wideband $|S_{21}| = f(f)$

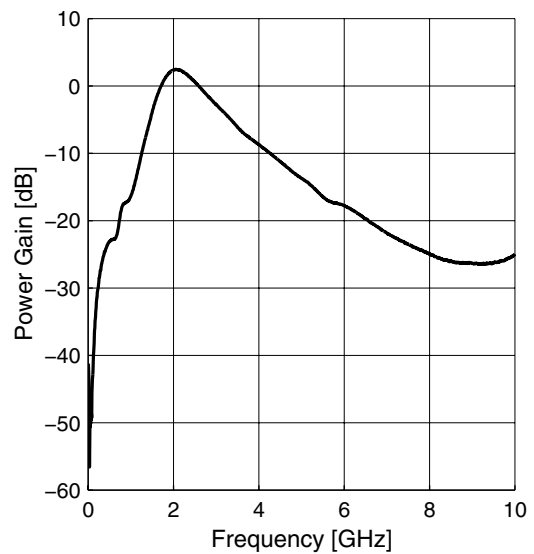

Measured Performance High Band Mid Gain Mode vs. Frequency

Matching $|S_{11}| = f(f)$, $|S_{22}| = f(f)$

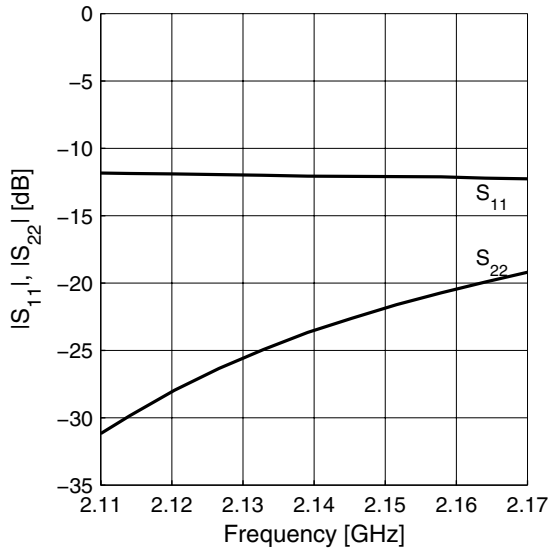

Reverse Isolation $|S_{12}| = f(f)$

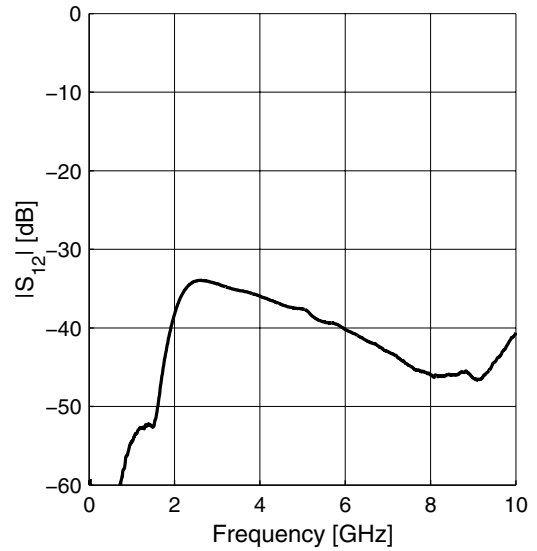

Noise Figure $NF = f(f)$

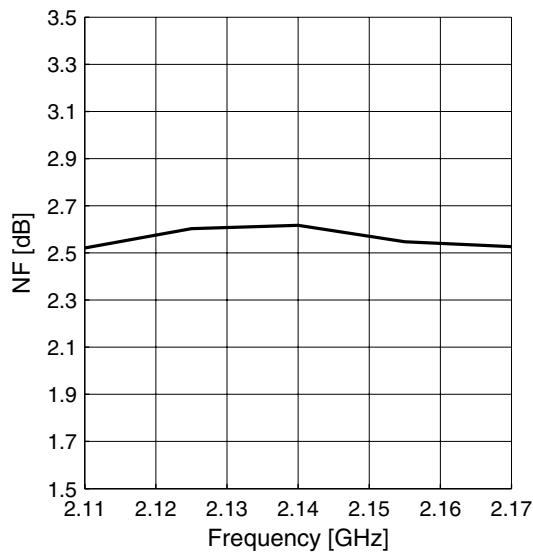

Input Compression $P_{1dB} = f(f)$

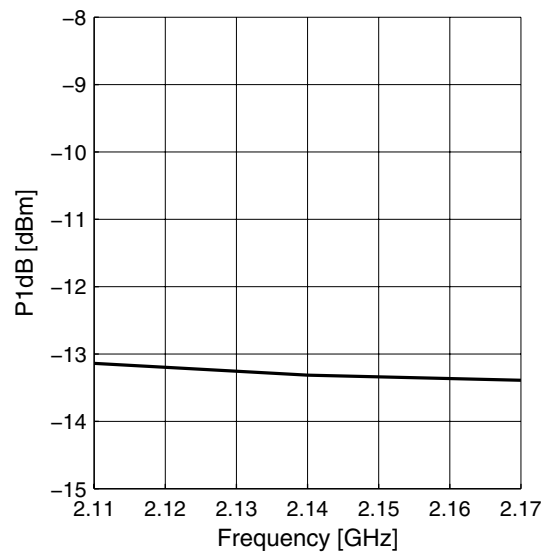

Measured Performance High Band Mid Gain Mode vs. Temperature

2.27 Measured Performance High Band Mid Gain Mode vs. Temperature

$V_{CC} = 2.8\text{ V}$, $V_{GS1} = 2.8\text{ V}$, $V_{GS2} = 2.8\text{ V}$, $V_{EN1} = 2.8\text{ V}$, $V_{EN2} = 2.8\text{ V}$, $R_{REF} = 8.2\text{ k}\Omega$

Power Gain $|S_{21}| = f(T_A)$

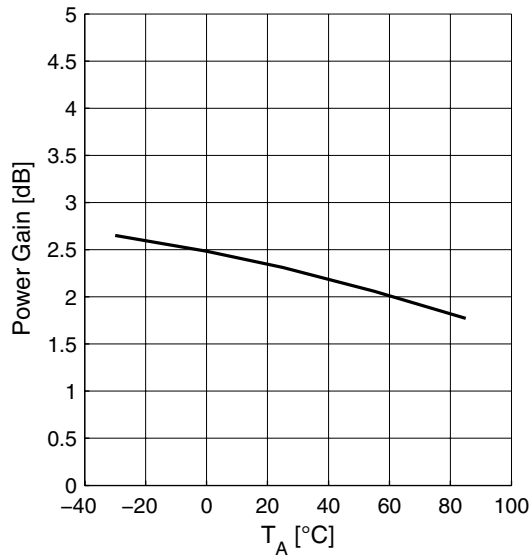

Supply Current $I_{CC} = f(T_A)$

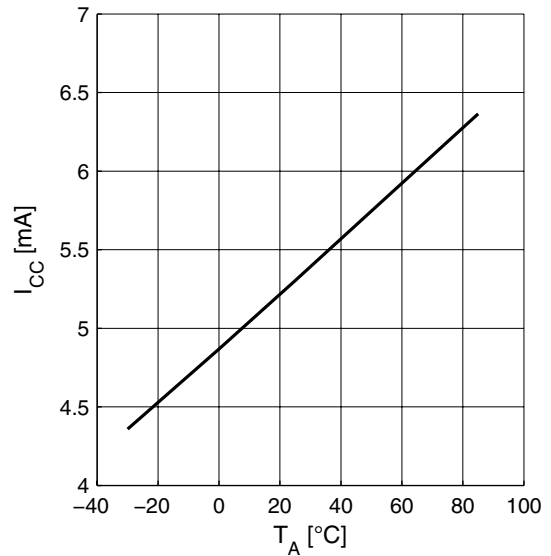

Noise Figure $NF = f(T_A)$

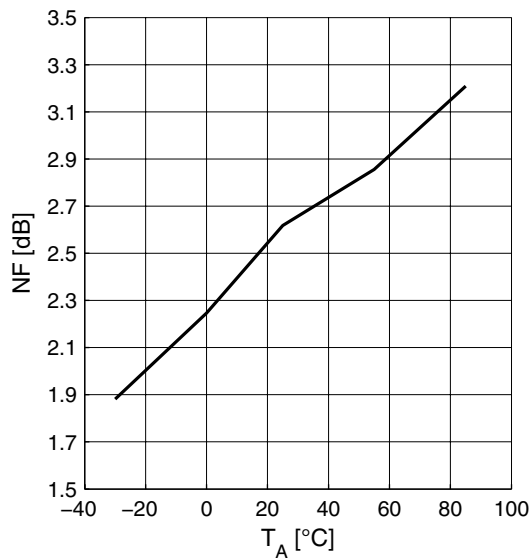

Input Compression $P_{1dB} = f(T_A)$

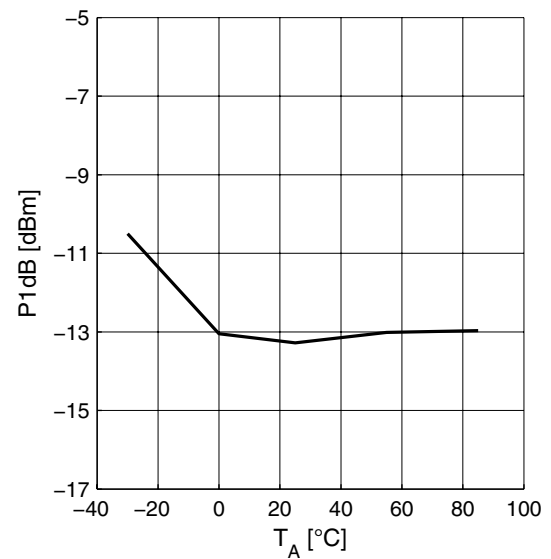

Measured Performance High Band Low Gain Mode vs. Frequency

2.28 Measured Performance High Band Low Gain Mode vs. Frequency

$T_A = 25\text{ }^\circ\text{C}$, $V_{CC} = 2.8\text{ V}$, $V_{GS1} = 0\text{ V}$, $V_{GS2} = 0\text{ V}$, $V_{EN1} = 2.8\text{ V}$, $V_{EN2} = 2.8\text{ V}$, $R_{REF} = 8.2\text{ k}\Omega$

Power Gain $|S_{21}| = f(f)$

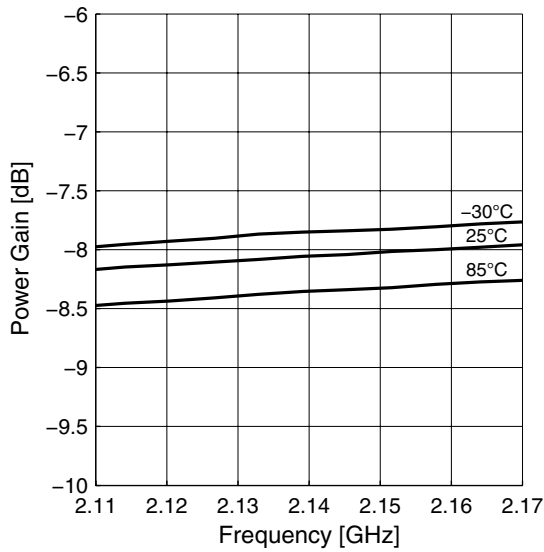

Power Gain Wideband $|S_{21}| = f(f)$

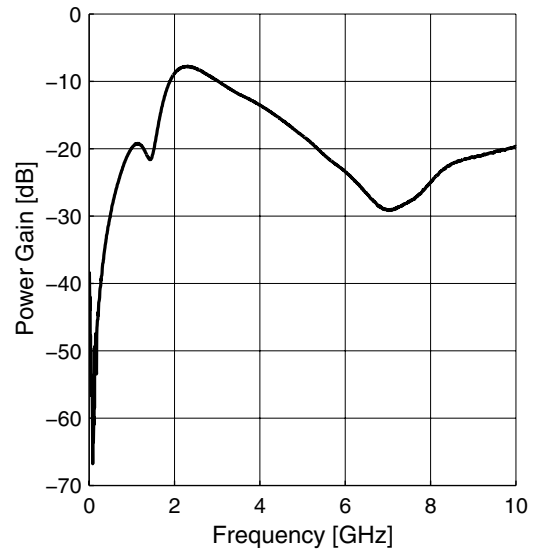

Matching $|S_{11}| = f(f)$, $|S_{22}| = f(f)$

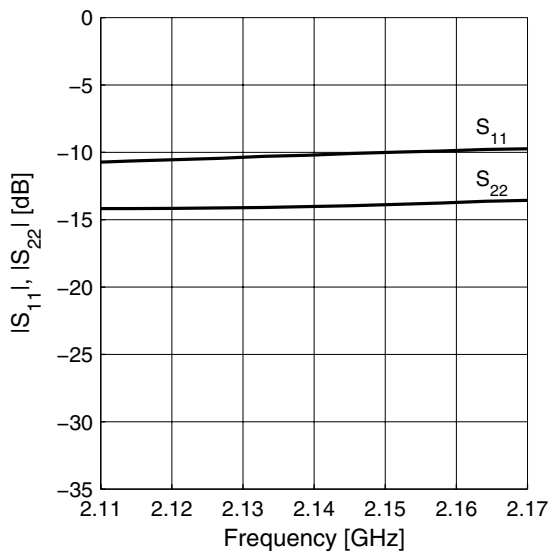

Reverse Isolation $|S_{12}| = f(f)$

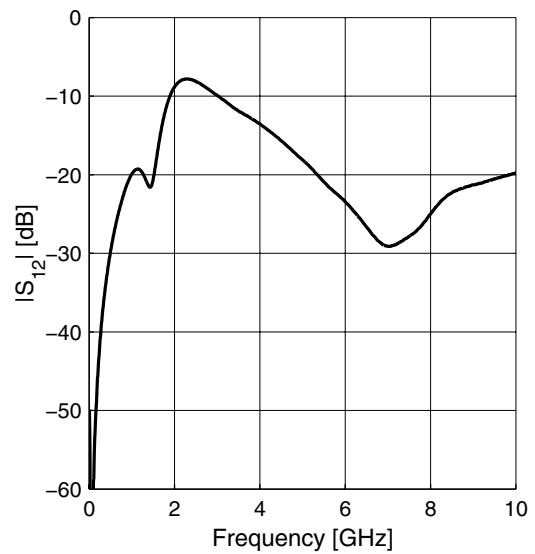

Measured Performance High Band Low Gain Mode vs. Temperature

Noise Figure $NF = f(f)$

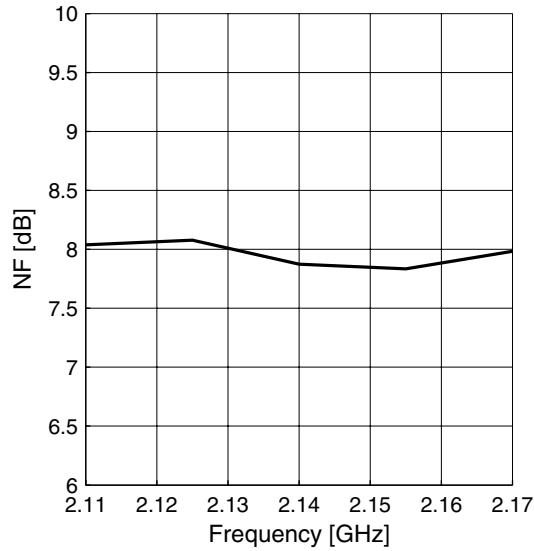

Input Compression $P_{1dB} = f(f)$

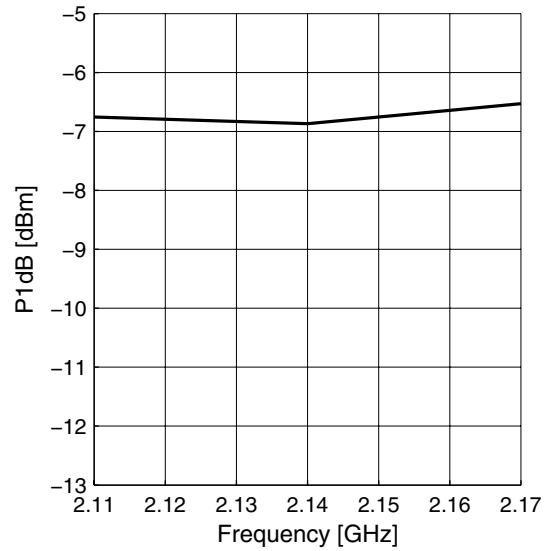

2.29 Measured Performance High Band Low Gain Mode vs. Temperature

$V_{CC} = 2.8 \text{ V}$, $V_{GS1} = 0 \text{ V}$, $V_{GS2} = 0 \text{ V}$, $V_{EN1} = 2.8 \text{ V}$, $V_{EN2} = 2.8 \text{ V}$, $R_{REF} = 8.2 \text{ k}\Omega$

Power Gain $|S_{21}| = f(T_A)$

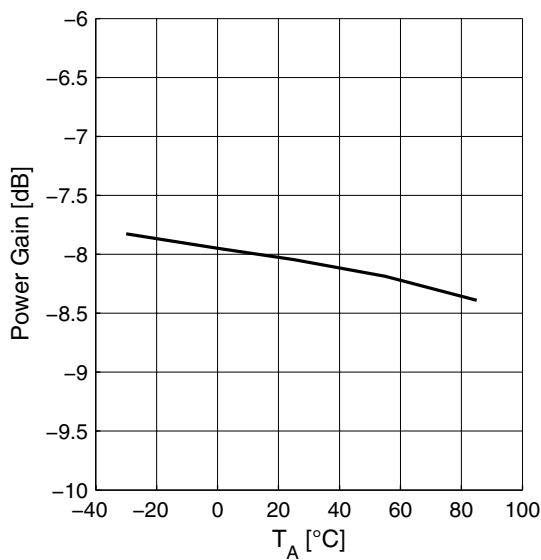

Supply Current $I_{CC} = f(T_A)$

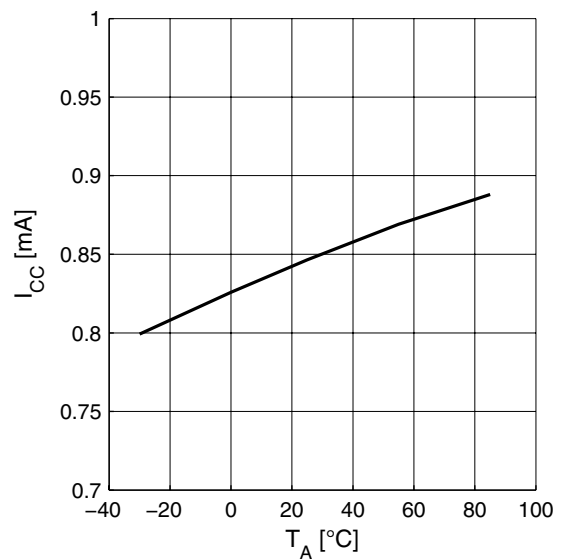

Measured Performance High Band Low Gain Mode vs. Temperature

Noise Figure $NF = f(T_A)$

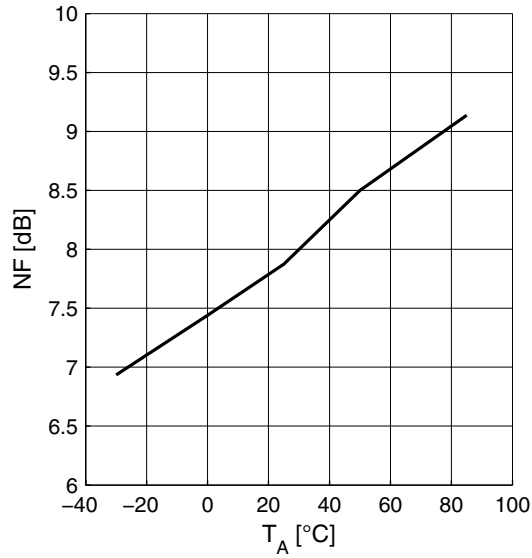

Input Compression $P_{1dB} = f(T_A)$

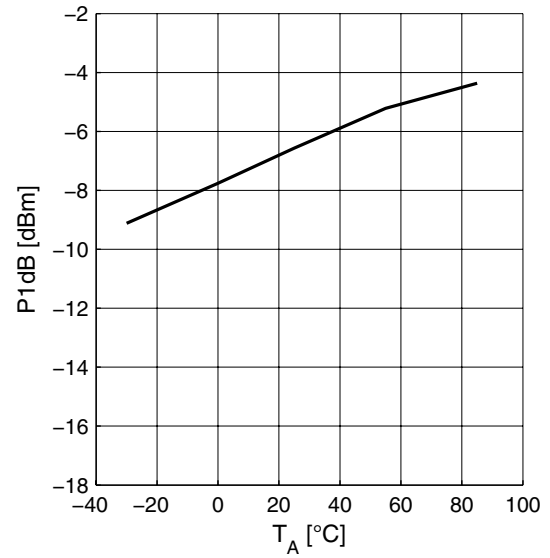

3 Application Circuit and Block Diagram

3.1 UMTS bands I, II and V Application Circuit Schematic

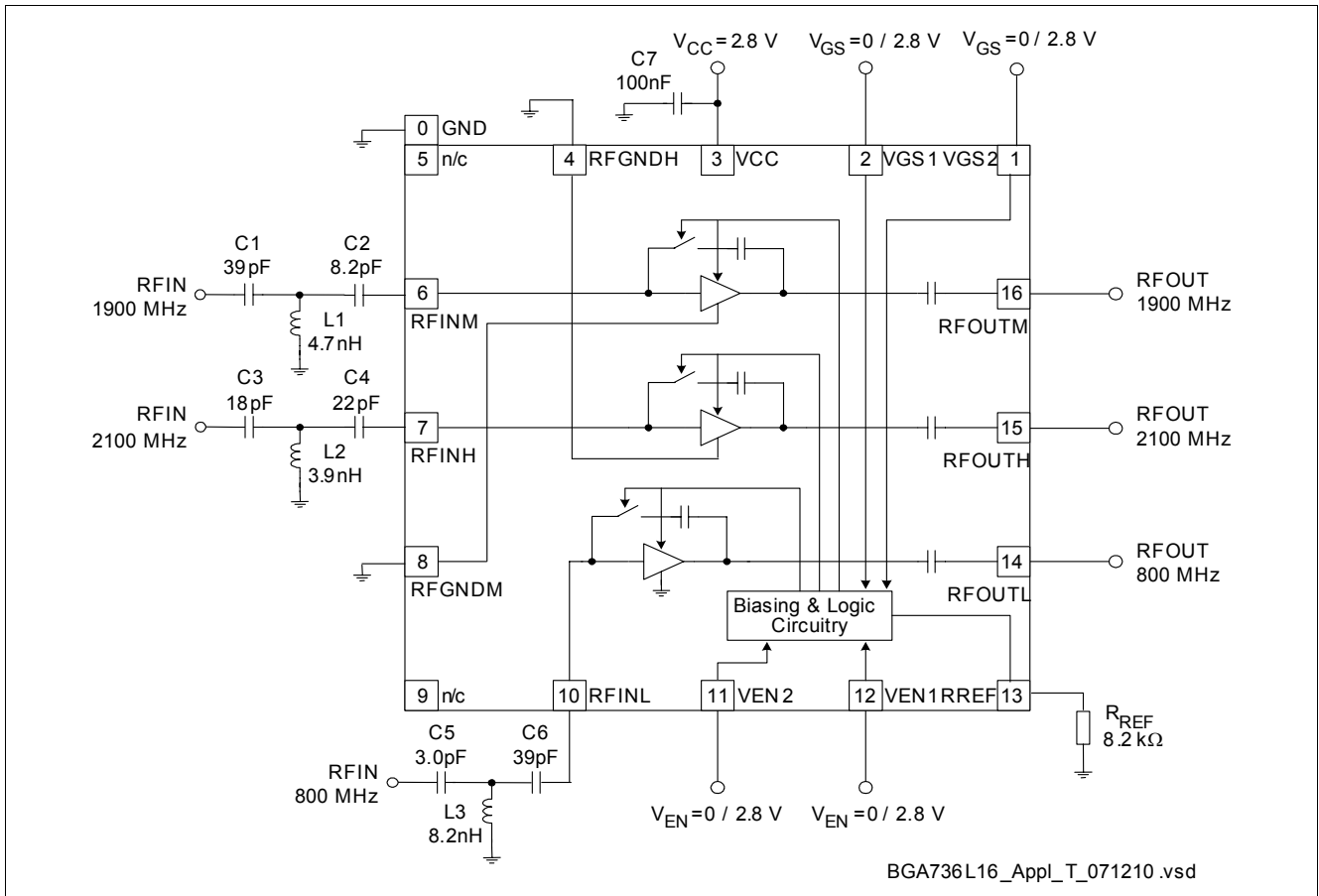

Figure 2 Application circuit with chip outline (top view)

Note: Package paddle (Pin 0) has to be RF grounded.

Table 13 Parts List

Part Number	Part Type	Manufacturer	Size	Comment
L1...L3	Chip inductor	Various	0402	Wirewound, Q ≈ 50
C1...C7	Chip capacitor	Various	0402	
R _{REF}	Chip resistor	Various	0402	

3.2 UMTS bands I, IV and VIII Application Circuit Schematic

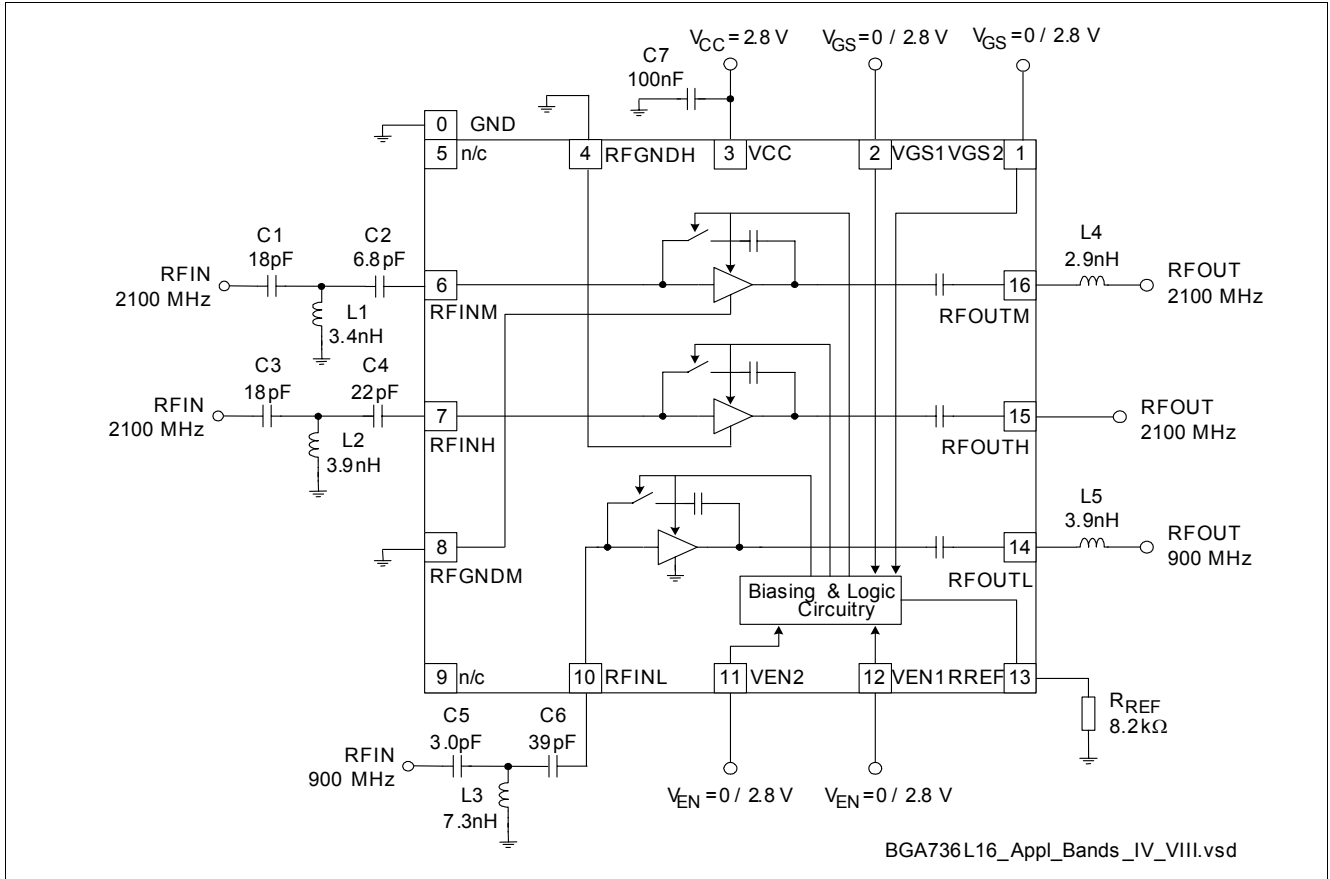

Figure 3 Application circuit with chip outline (top view)

Note: Package paddle (Pin 0) has to be RF grounded.

Table 14 Parts List

Part Number	Part Type	Manufacturer	Size	Comment
L1...L5	Chip inductor	Various	0402	Wirewound, Q ≈ 50
C1...C7	Chip capacitor	Various	0402	
R _{REF}	Chip resistor	Various	0402	

3.3 Pin Definition

Table 15 Pin Definition and Function

Pin Number	Symbol	Function
0	GND	Ground connection for low band (800/900 MHz) LNA and control circuitry (package paddle)
1	VGS2	Gain step control
2	VGS1	Gain step control
3	VCC	Supply voltage
4	RFGNDH	High band (2100 MHz) LNA RF ground
5	n/c	Not connected
6	RFINM	Mid band (1900/2100 MHz) LNA input
7	RFINH	High band (2100 MHz) LNA input
8	RFGNDM	Mid band (1900/2100 MHz) LNA RF ground
9	n/c	Not connected
10	RFINL	Low band (800/900 MHz) LNA input
11	VEN2	Band select control
12	VEN1	Band select control
13	RREF	Bias current reference resistor (high / mid gain mode)
14	RFOUTL	Low band (800/900 MHz) LNA output
15	RFOUTH	High band (2100 MHz) LNA output
16	RFOUTM	Mid band (1900/2100 MHz) LNA output

3.4 Application Board

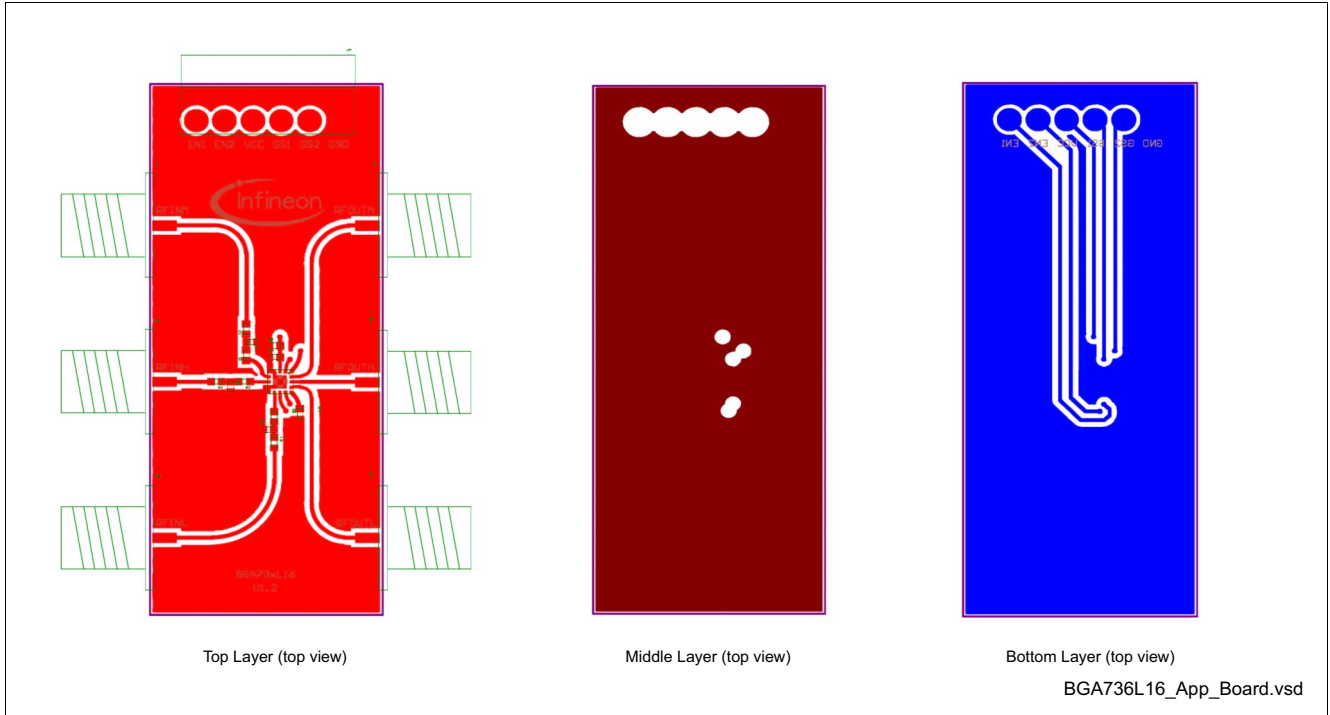

Figure 4 Application board layout on 3-layer FR4. Top layer thickness: 0.2 mm, bottom layer thickness: 0.8 mm, 35 μm Cu metallization, gold plated. Board size: 20 x 50 mm

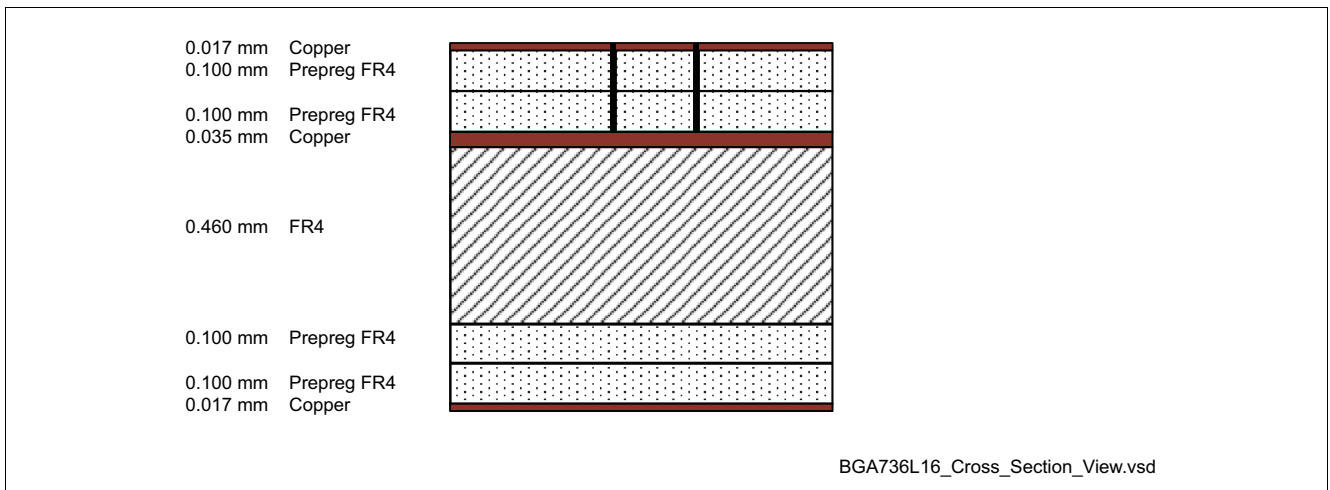

Figure 5 Cross-section view of application board

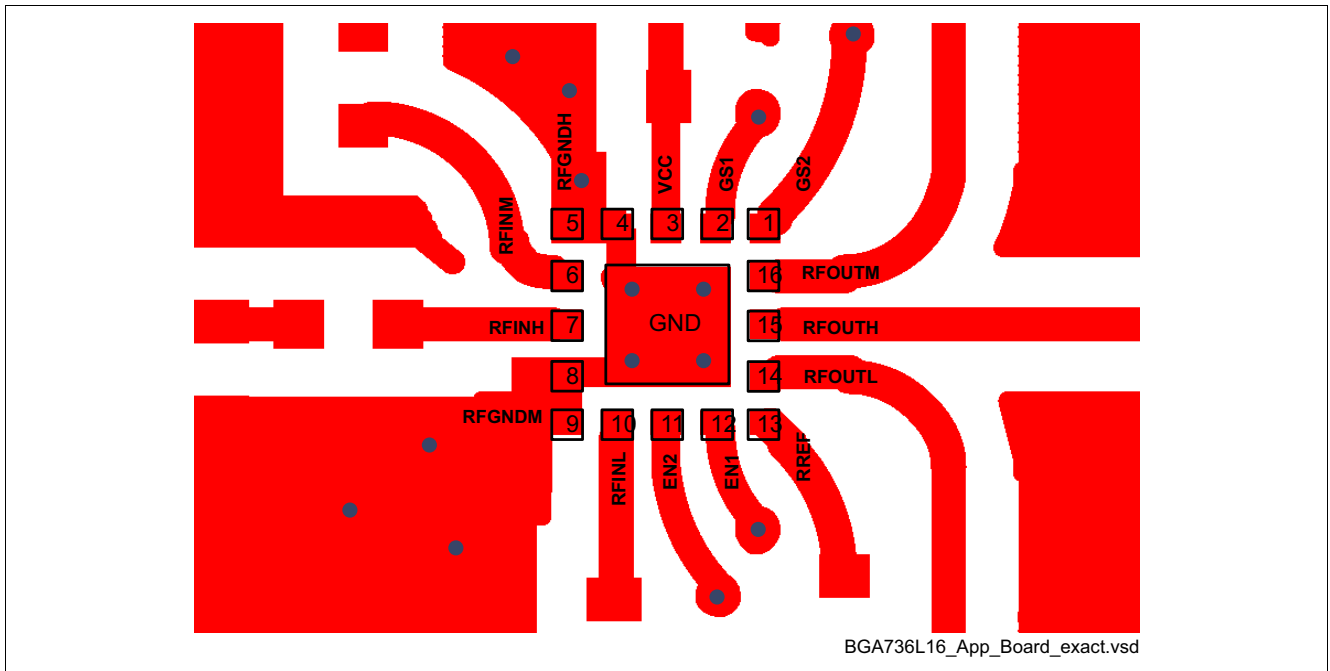

Figure 6 Detail of application board layout

Note: In order to achieve the same performance as given in this datasheet please follow the suggested PCB-layout as closely as possible. The position of the GND vias is critical for RF performance.

4 Physical Characteristics

4.1 Package Footprint

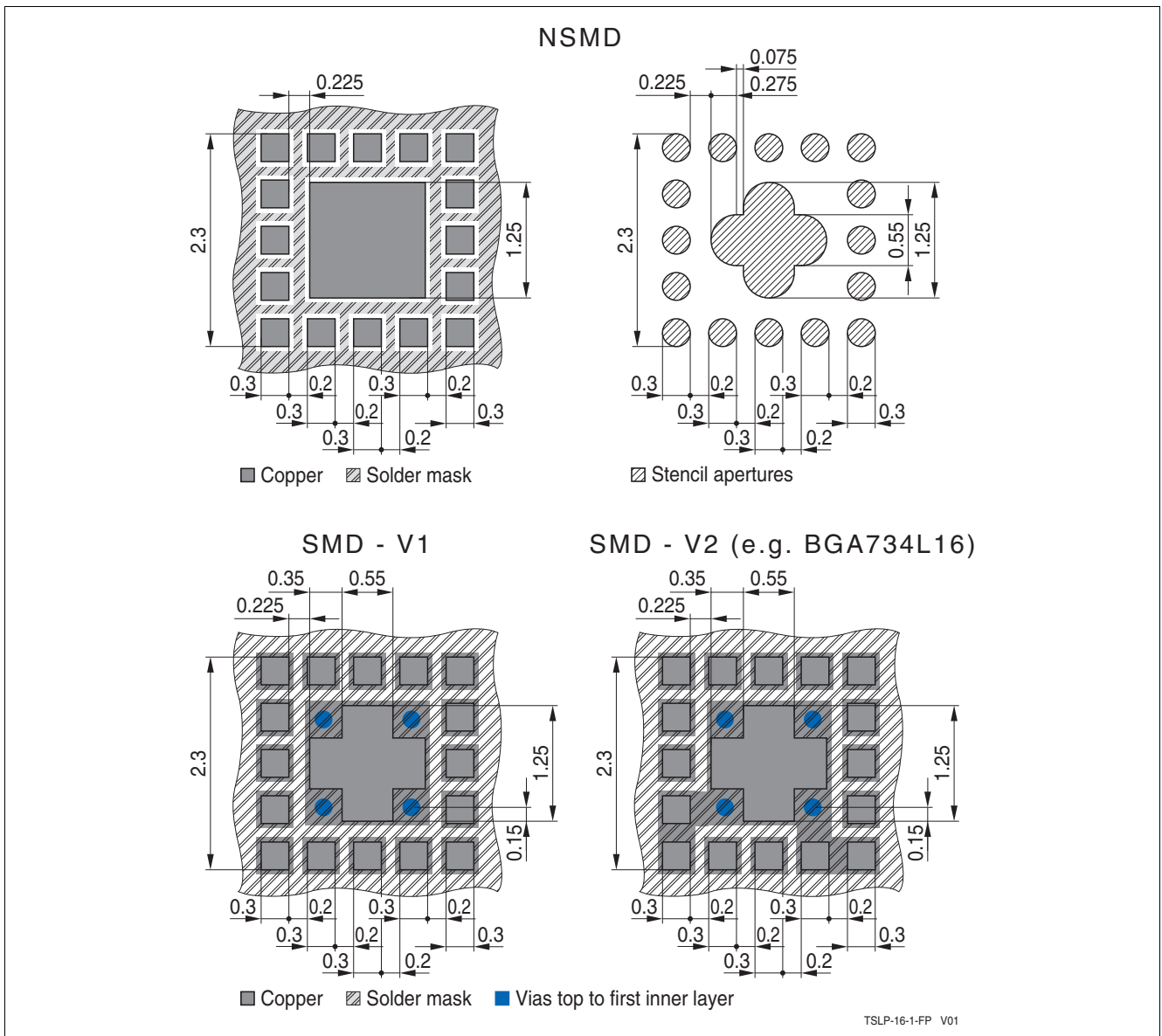

Figure 7 Recommended footprint and stencil layout for the TSLP-16-1 package. SMD - V2 footprint is used on IFX application board

4.2 Package Dimensions

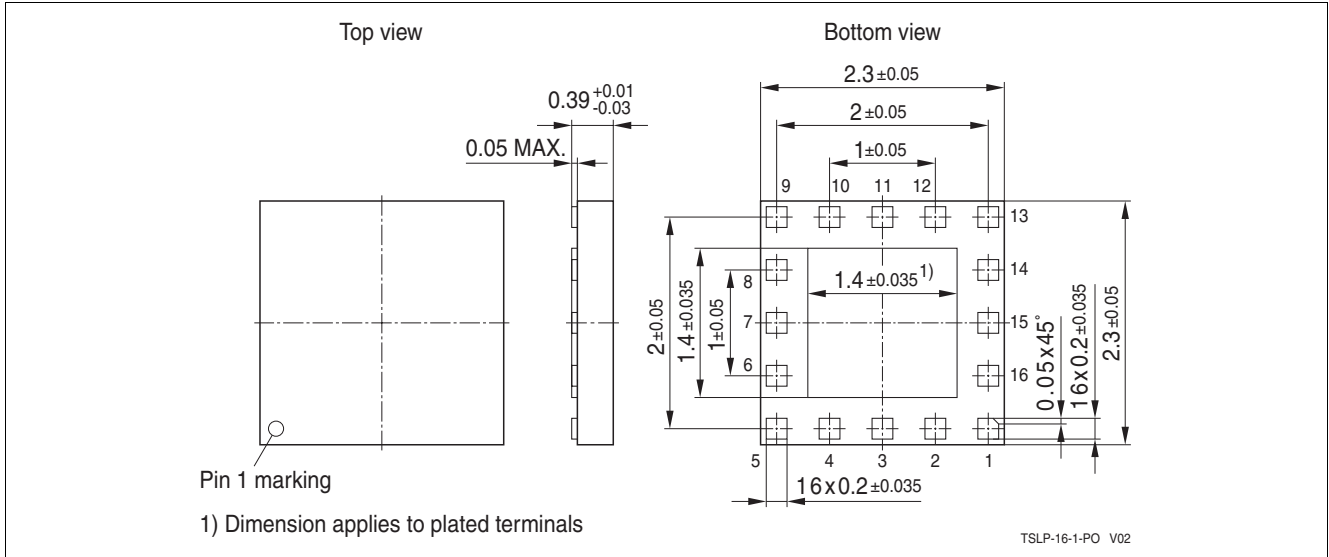



Figure 8 Package outline (top, side and bottom view)

www.infineon.com

Published by Infineon Technologies AG

Looking for pricing, stock, or lifecycle information?

Click below to explore more details on WIN SOURCE:

-  [View BGA736L16E6327XTSA1 on WIN SOURCE](#)
-  [Infineon Technologies Information](#)

Optimize Your Supply Chain with WIN SOURCE Solutions

-  Global Sourcing Solution
-  Obsolete Management
-  Cost Control Management
-  Shortage Management
-  Alternative Solution
-  Excess Inventory Management