



THE DATASHEET OF BD8205EFV-ME2



System motor driver for CD/DVD Player

5ch System Motor Driver for Car AV

BD8205EFV-M

General Description

BD8205EFV-M is a 5-Channel system motor driver developed for DC motors (Spindle motor, Sled motor, Loading motor) and coils (Tracking, Focus) drive for actuator. This IC can drive the motor and the coil of a CD/DVD drive.

Features

- 5CH BTL Driver
- POWVCC1 for CHs 1, 2, and 3 (DC motors) and POWVCC2 for CHs 4 and 5 (actuator) are independent for efficient drive configuration.
- Built-in protection functions (TSD, UVLO, BIAS Drop Mute)
- AEC-Q100 Qualified

Application

Car Audio

Key Specifications

- Driver Power Supply Voltage Range
POWVCC1 6V to 10V
POWVCC2 4.3V to $V_{POWVCC1}$
- Operating Temperature Range -40°C to +85°C
- Output Offset (CHs 1,2,3) ±100mV (Max)
- Output Offset (CHs 4,5) ±50mV (Max)
- Maximum Output Range (All CHs) 6V (Typ)

Package

HTSSOP-B24

W(Typ) D(Typ) H(Max)
7.80mm × 7.60mm × 1.00mm

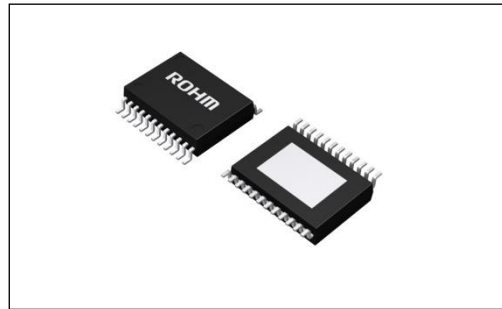

HTSSOP-B24

Typical Application Circuit

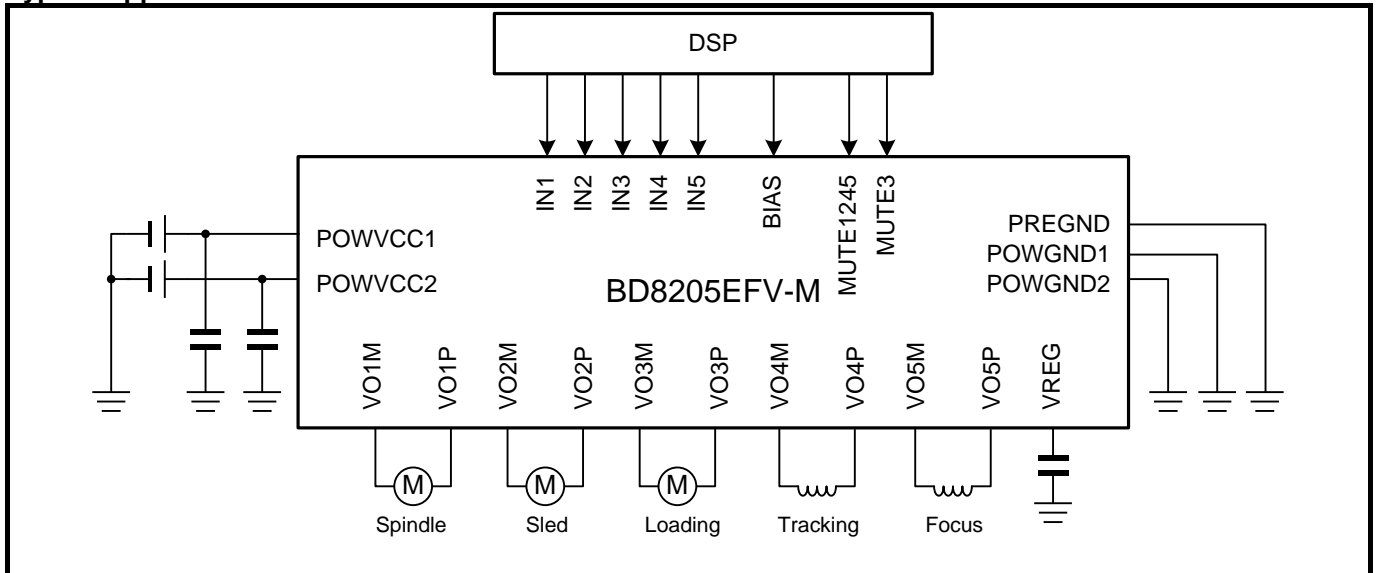

Figure 1. Typical Application Circuit

Pin Configuration

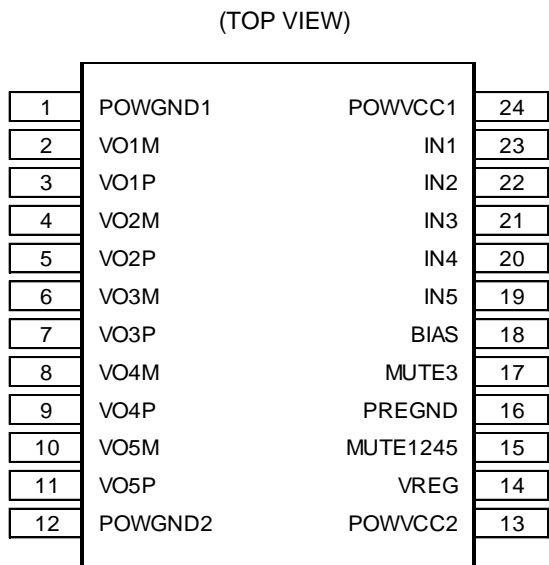

Figure 2. Pin Configuration

Pin Descriptions

No.	Pin Name	Function
1	POWVCC1	Power GND1
2	VO1M	CH1 driver negative output
3	VO1P	CH1 driver positive output
4	VO2M	CH2 driver negative output
5	VO2P	CH2 driver positive output
6	VO3M	CH3 driver negative output
7	VO3P	CH3 driver positive output
8	VO4M	CH4 driver negative output
9	VO4P	CH4 driver positive output
10	VO5M	CH5 driver negative output
11	VO5P	CH5 driver positive output
12	POWVCC2	Power GND2
13	POWVCC2	Power supply voltage 2
14	VREG	Power supply for internal logic
15	MUTE1245	Mute control input for CHs 1, 2, 4, 5
16	PREGND	Pre GND
17	MUTE3	Mute control input for CH 3
18	BIAS	Standard voltage input
19	IN5	CH5 input
20	IN4	CH4 input
21	IN3	CH3 input
22	IN2	CH2 input
23	IN1	CH1 input
24	POWVCC1	Power supply voltage 1

Block Diagram

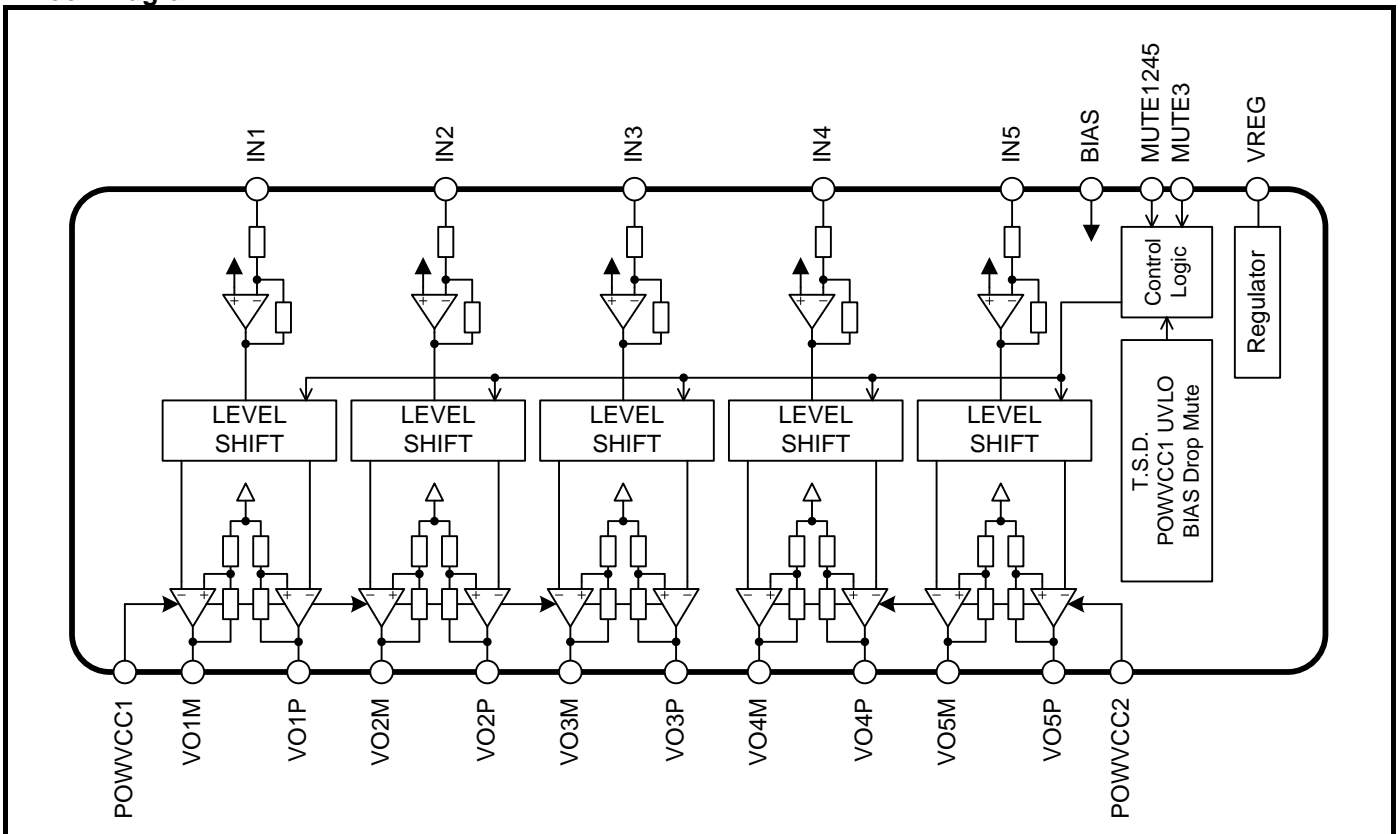

Figure 3. Block Diagram

Absolute Maximum Ratings (Ta=25°C)

Parameter	Symbol	Rating	Unit
Power Supply Voltage 1	V _{POWVCC1}	12	V
Power Supply Voltage 2	V _{POWVCC2}	V _{POWVCC1}	V
Input Pin Voltage 1	V _{IN1} (Note 1)	12	V
Input Pin Voltage 2	V _{IN2} (Note 2)	7	V
Package Dissipation	Pd	1.10 (Note 3)	W
		3.99 (Note 4)	
Operating Temperature Range	T _{opr}	-40 to +85	°C
Storage Temperature Range	T _{stg}	-55 to +150	°C
Maximum Junction Temperature	T _{jmax}	+150	°C

(Note 1) This is applicable to pins MUTE1245 and MUTE3.

(Note 2) This is applicable to pins IN1, IN2, IN3, IN4, IN5, and BIAS.

(Note 3) Glass epoxy substrate dimensions are 70mmx70mmx1.6mm, 1 layer substrate, (Copper foil 0mmx0mm)

Reduce power dissipation capability by 8.8mW for each degree above 25°C.

(Note 4) Glass epoxy substrate dimensions are 70mmx70mmx1.6mm, 4 layer substrate, (Copper foil 70mmx70mm)

Reduce power dissipation capability by 32.0mW for each degree above 25°C.

Caution: Operating the IC over the absolute maximum ratings may damage the IC. The damage can either be a short circuit between pins or an open circuit between pins and the internal circuitry. Therefore, it is important to consider circuit protection measures, such as adding a fuse, in case the IC is operated over the absolute maximum ratings.

Recommended Operating Conditions (Ta = -40°C to +85°C)

Parameter	Symbol	Min	Typ	Max	Unit
Pre Block Power Supply, DC Motor System Power Supply (Note 1)	V _{POWVCC1}	6	8	10	V
Actuator System Power Supply (Note 1)	V _{POWVCC2}	4.3	8	V _{POWVCC1}	V

(Note 1) Please decide the power supply voltage after considering power dissipation.

Electrical Characteristics (Unless otherwise noted $T_a=25^{\circ}\text{C}$, $V_{\text{POWVCC1}}=V_{\text{POWVCC2}}=8\text{V}$, $V_{\text{BIAS}}=1.65\text{V}$, $R_L=8\Omega$)

Parameter	Symbol	Limit			Unit	Condition
		Min	Typ	Max		
Quiescent Current	I_Q	—	13	30	mA	At no-load, $V_{\text{MUTE1245,3}}=H$
< Driver >						
Output Offset (CHs 1, 2, 3)	V_{OOF123}	-100	0	100	mV	
Output Offset (CHs 4, 5)	V_{OOF45}	-50	0	50	mV	
Maximum Output Range (CHs 1, 2, 3, 4, 5)	V_{OM}	5.3	6.0	—	V	Total $R_{\text{ON}}=2.5\Omega$ (Typ) Equivalent
Closed Circuit Loop Gain (CHs 1, 2, 3)	G_{V123}	24.0	25.7	27.4	dB	
Closed Circuit Loop Gain (CHs 4, 5)	G_{V45}	15.5	17.5	19.5	dB	
Input Impedance (CHs 1, 2, 3)	R_{IN123}	13	20	27	k Ω	
Input Impedance (CHs 4, 5)	R_{IN45}	30	47	64	k Ω	
< Others >						
MUTE1245,3 Low Level Voltage	V_{ML}	—	—	0.5	V	
MUTE1245,3 High Level Voltage	V_{MH}	2.0	—	—	V	
MUTE1245,3 Input Current	I_{MUTE}	32	52	74	μA	$V_{\text{MUTE1245,3}}=3.3\text{V}$
BIAS Drop Mute	V_{BIAS}	0.5	0.7	0.9	V	
BIAS Input Current	I_{BIAS}	32	52	74	μA	$V_{\text{BIAS}}=1.65\text{V}$
UVLO Detection Voltage	V_{UVLOD}	3.4	3.8	4.2	V	
UVLO Release Voltage	V_{UVLOR}	3.6	4.0	4.4	V	
VREG Voltage	V_{VREG}	—	5.0	—	V	$C_{\text{VREG}}=0.1\mu\text{F}$

Electrical Characteristics(Unless otherwise noted Ta=-40°C to 85°C, V_{POWVCC1}=V_{POWVCC2}=8V, V_{BIAS}=1.65V, R_L=8Ω)

Parameter	Symbol	Limit			Unit	Condition
		Min	Typ	Max		
Quiescent Current	I _Q	—	13	33	mA	At no-load, V _{MUTE1245,3} =H
< Driver >						
Output Offset (CHs 1, 2, 3)	V _{OOFF123}	-100	0	100	mV	
Output Offset (CHs 4, 5)	V _{OOFF45}	-50	0	50	mV	
Maximum Output Range (CHs 1, 2, 3, 4, 5)	V _{OM}	4.8	6.0	—	V	Total RON=2.5Ω(Typ) Equivalent
Closed Circuit Loop Gain (CHs 1, 2, 3)	G _{V123}	24.0	25.7	27.4	dB	
Closed Circuit Loop Gain (CHs 4, 5)	G _{V45}	15.5	17.5	19.5	dB	
Input Impedance (CHs 1, 2, 3)	R _{IN123}	10	20	28	kΩ	
Input Impedance (CHs 4, 5)	R _{IN45}	28	47	66	kΩ	
< Others >						
MUTE1245,3 Low Level Voltage	V _{ML}	—	—	0.4	V	
MUTE1245,3 High Level Voltage	V _{MH}	2.0	—	—	V	
MUTE1245,3 Input Current	I _{MUTE}	22	52	108	μA	V _{MUTE1245,3} =3.3V
BIAS Drop Mute	V _{BIAS}	0.3	0.7	1.1	V	
BIAS Input Current	I _{BIAS}	22	52	108	μA	V _{BIAS} =1.65V
UVLO Detection Voltage	V _{UVLO}	3.4	3.8	4.2	V	
UVLO Release Voltage	V _{UVLOR}	3.6	4.0	4.4	V	
VREG Voltage	V _{VREG}	—	5.0	—	V	C _{VREG} =0.1μF

Typical Performance Curves

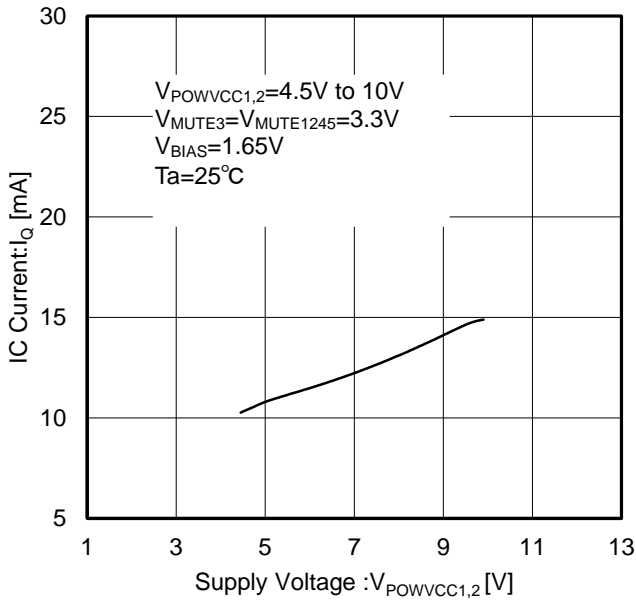

Figure 4. Quiescent Current: I_q

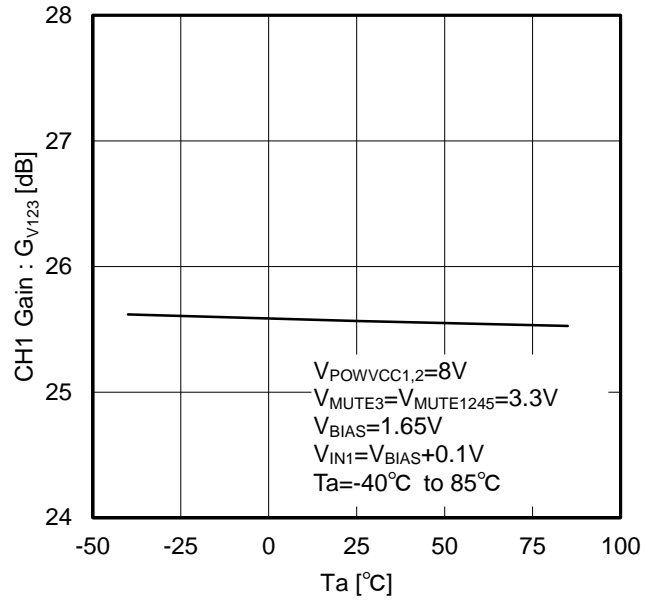

Figure 5. CH1 Closed Circuit Loop Gain: G_{V123}

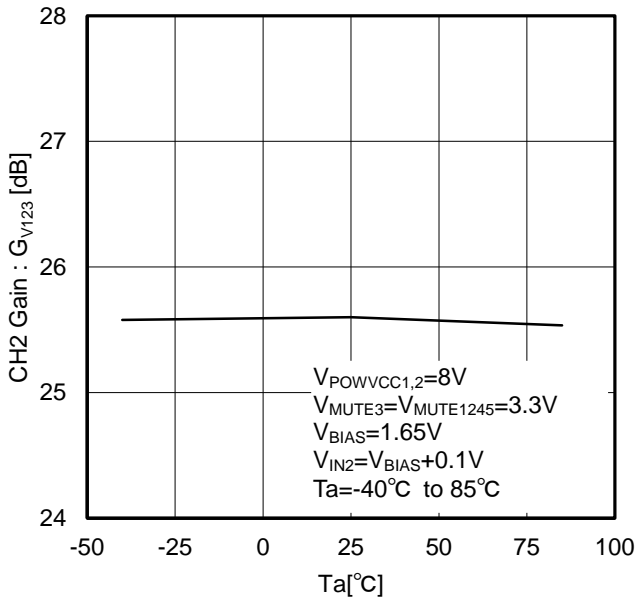

Figure 6. CH2 Closed Circuit Loop Gain: G_{V123}

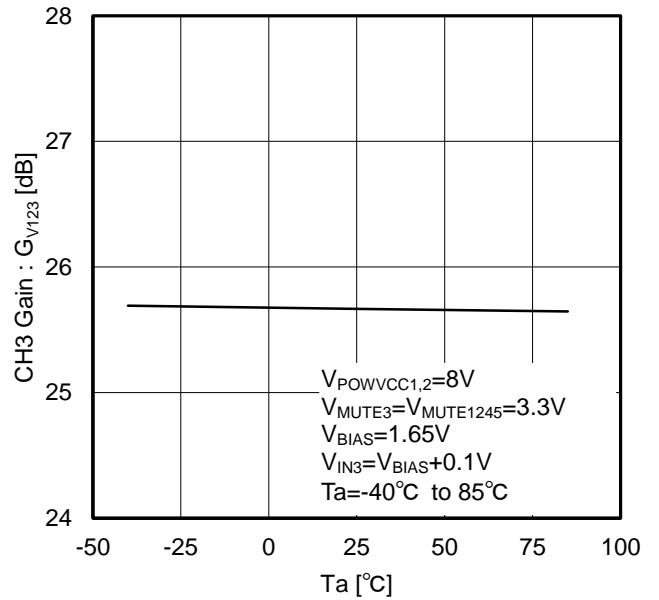

Figure 7. CH3 Closed Circuit Loop Gain: G_{V123}

Typical Performance Curves

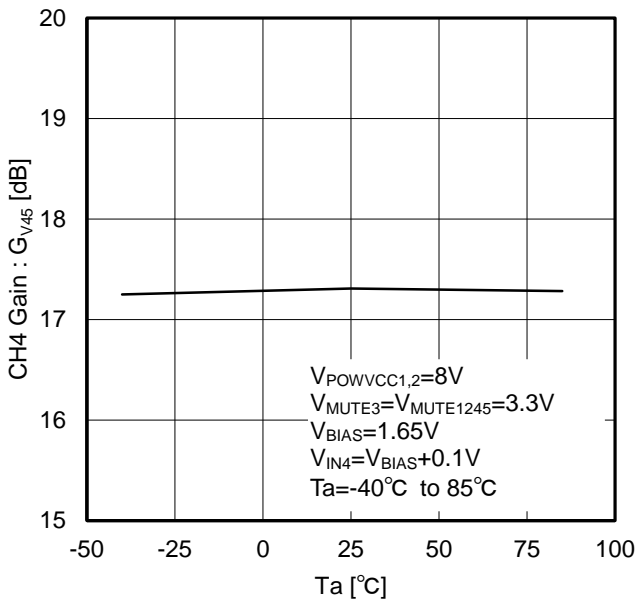

Figure 8. CH4 Closed Circuit Loop Gain: G_{V45}

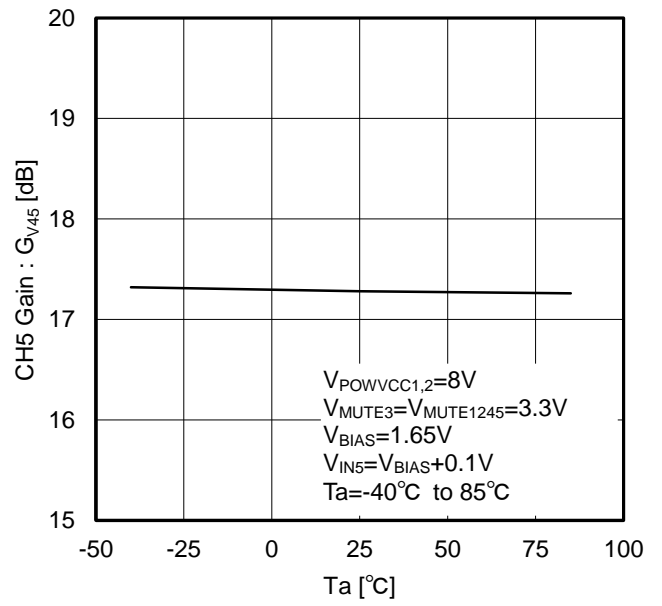

Figure 9. CH5 Closed Circuit Loop Gain: G_{V45}

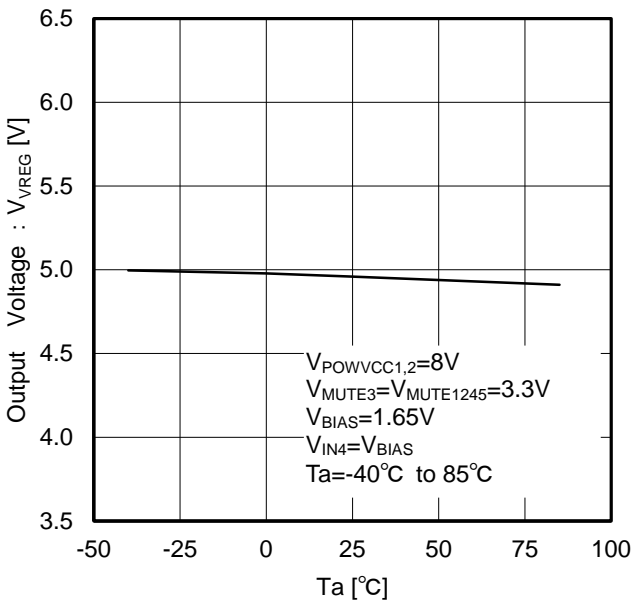

Figure 10. VREG Voltage: V_{VREG}

Description of Block

1. Driver Control Pins MUTE1245 (Pin15), MUTE3 (Pin17), BIAS (Pin18)

All driver output conditions are controlled by switching the MUTE1245 and MUTE3 pins to High and Low levels. Shown below is the input-output logic table including BIAS drop mute.

▼Driver Logic (Normal Operation)

State No.	Input			Output ^{(Note 1) (Note 2)}				
	MUTE1245	MUTE3	BIAS	CH1 (SP)	CH2 (SL)	CH3 (LD)	CH4 (FC)	CH5 (TK)
1	H	H	H	Active	Active	Active	Active	Active
2	H	L	H	Active	Active	MUTE	Active	Active
3	L	H	H	MUTE	MUTE	Active	MUTE	MUTE
4	L	L	H	MUTE	MUTE	MUTE	MUTE	MUTE
5	H	H	L	MUTE	MUTE	MUTE	MUTE	MUTE
6	H	L	L	MUTE	MUTE	MUTE	MUTE	MUTE
7	L	H	L	MUTE	MUTE	MUTE	MUTE	MUTE
8	L	L	L	Hi-Z	Hi-Z	Hi-Z	Hi-Z	Hi-Z

▼Driver Logic (UVLO, TSD Protected Operation)

State No.	Input			Output ^{(Note 1) (Note 2)}				
	MUTE1245	MUTE3	BIAS	CH1 (SP)	CH2 (SL)	CH3 (LD)	CH4 (FC)	CH5 (TK)
9	L	L	L	Hi-Z	Hi-Z	Hi-Z	Hi-Z	Hi-Z
10	Others			MUTE	MUTE	MUTE	MUTE	MUTE

(Note 1) MUTE : Both positive and negative output voltages pull-up to POWVCC/2(=V_{REF}).

(Note 2) Hi-Z : Both positive and negative outputs become Hi-Z.

2. BIAS Drop Mute

If BIAS pin voltage becomes 0.7V (Typ) or less, output of all channels turns OFF. Please set it to a minimum of 1.2V for typical use.

3. POWVCC1 Drop Mute (UVLO)

If POWVCC1 pin voltage becomes 3.8V (Typ) or less, output of all channels turns OFF. If POWVCC1 pin voltage becomes 4.0V (Typ) or more, output of all channels turns ON.

4. Thermal Shutdown Circuit (TSD)

Thermal shutdown circuit is designed to turn off all output channels when the junction temperature (T_j) reaches 175°C (Typ). IC operation begins again when the junction temperature decreases to 150°C (Typ) or less.

5. VREG Voltage (Pin14)

VREG pin is the regulator output for internal blocks. 5V (Typ) is generated on this pin using POWVCC1 power supply. Connect a capacitor C_{VREG} = 0.1μF (Typ) to the VREG pin for phase compensation. Operation may become unstable if C_{VREG} is not connected. VREG is not designed as the power supply for other parts. Therefore connect only a capacitor to VREG pin.

6. Output Amplitude calculation

i) SPINDLE,SLED,LOADING

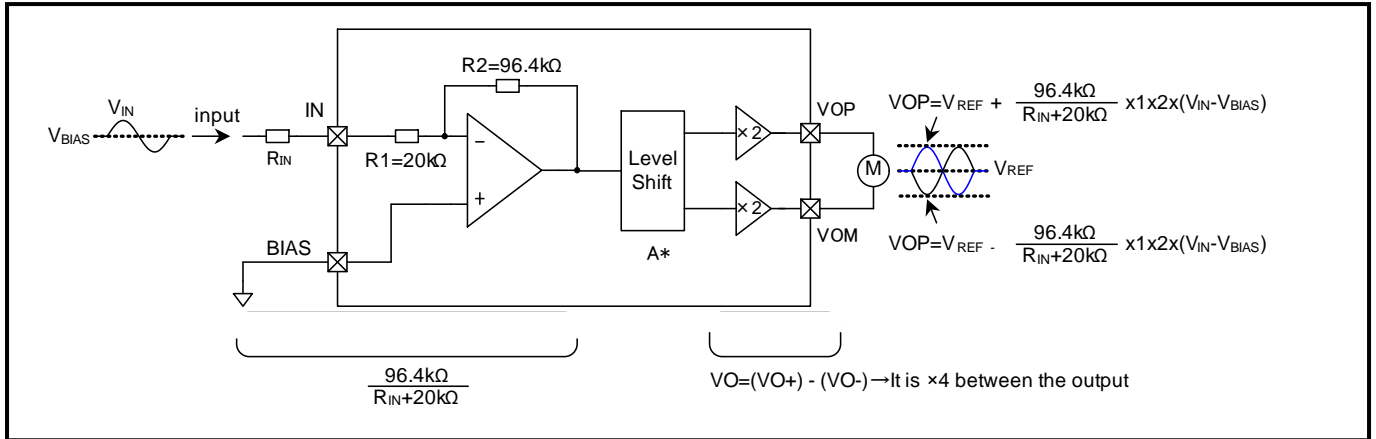

Figure 11. SPINDLE, SLED, LOADING Closed Loop Gain calculation

$$Gain = \frac{96.4k\Omega}{R_{IN} + 20k\Omega} \times 1 \times 2 \times 2 \text{ [dB]}$$

Example: $R_{IN}=0$.

$$Gain = \frac{96.4k\Omega}{20k\Omega} \times 1 \times 2 \times 2 = 25.7 \text{ [dB]}$$

※Please consider component dispersion

$R1 = 20k\Omega \pm 18\%$

$R2 = 96.4k\Omega \pm 18\%$

$R2/R1 = 4.82 \pm 2.5\%$

* $A = 1 \pm 18\%$

ii) FOCUS, TRACKING

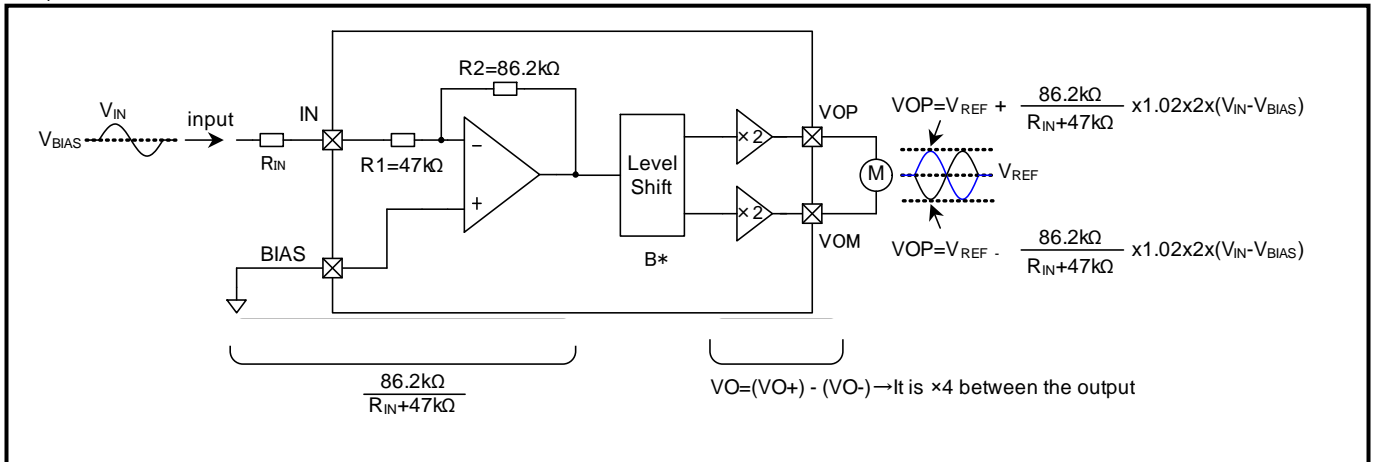

Figure 12. FOCUS, TRACKING Closed Loop Gain calculation

$$Gain = \frac{86.2k\Omega}{R_{IN} + 47k\Omega} \times 1.02 \times 2 \times 2 \text{ [dB]}$$

Example: $R_{IN}=0$.

$$Gain = \frac{86.2k\Omega}{47k\Omega} \times 1.02 \times 2 \times 2 = 17.5 \text{ [dB]}$$

※Please consider component dispersion

$R1 = 47k\Omega \pm 18\%$

$R2 = 86.2k\Omega \pm 18\%$

$R2/R1 = 4.82 \pm 2.5\%$

* $B = 1.02 \pm 26\%$

Timing Chart

1. Kind of the signals

- External power supply : POWVCC1, POWVCC2
- Internal power supply : VREG
- Reference voltage input : BIAS
- Driver input : IN1, IN2, IN3, IN4, IN5
- Mute control input : MUTE1245, MUTE3
- Driver output : VO1P, VO1M, VO2P, VO2M, VO3P, VO3M, VO4P, VO4M, VO5P, VO5M,

2. Start-up Sequence

- (1) Input external power supply. The slew rate recommends less than $0.045\text{V}/\mu\text{s}$ in the start-up before the power supply voltage arrive at 5V. When the power supply voltage quickly start-up, an overshoot of the VREG voltage occurs and may lead to internal element destruction. Keep relations of $\text{POWVCC1} \geq \text{POWVCC2}$ at the start-up.
- (2) Input reference voltage (BIAS). Because BIAS is sequence-free, BIAS input before the external power supply at start-up is possible.
- (3) After the POWVCC1 power supply voltage arrived at 4.0V (UVLO release voltage), input the mute control.
- (4) After input the mute control, input any voltage into each driver input.

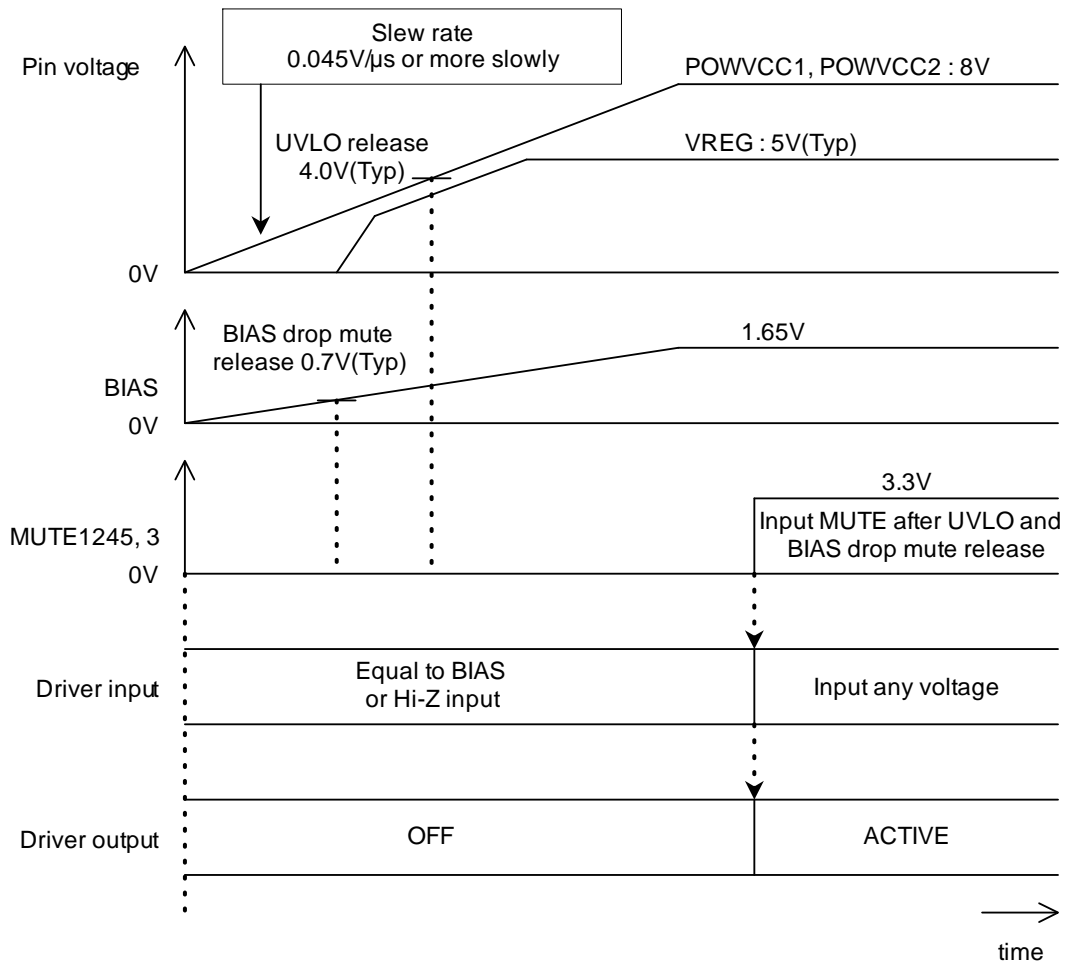

Figure 13. Example of start-up sequence

3. Shut-down Sequence

- (1) Turn off the driver input and the mute control input.
- (2) Turn off the reference voltage input (BIAS). Because BIAS is sequence-free, turn off after the power supply turn off is possible.
- (3) The slew rate recommends more than $-0.045\text{V}/\mu\text{s}$ in the shut-down after the power supply voltage lower than 5V. When the power supply voltage quickly shut-down, the discharge current from C_{VREG} becomes the overcurrent and may lead to internal element destruction. Keep relations of $\text{POWVCC1} \geq \text{POWVCC2}$ at the shut-down also.

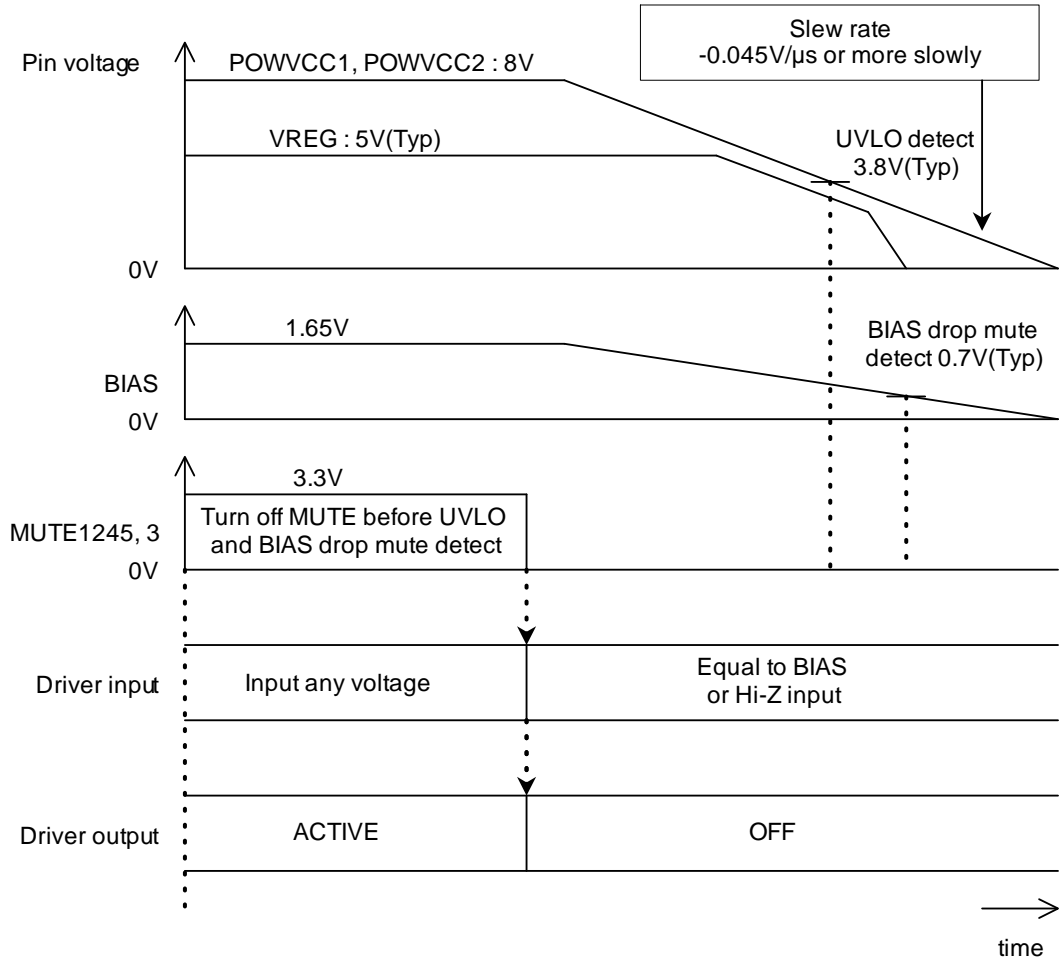

Figure 14. Example of shut-down sequence

Application Example

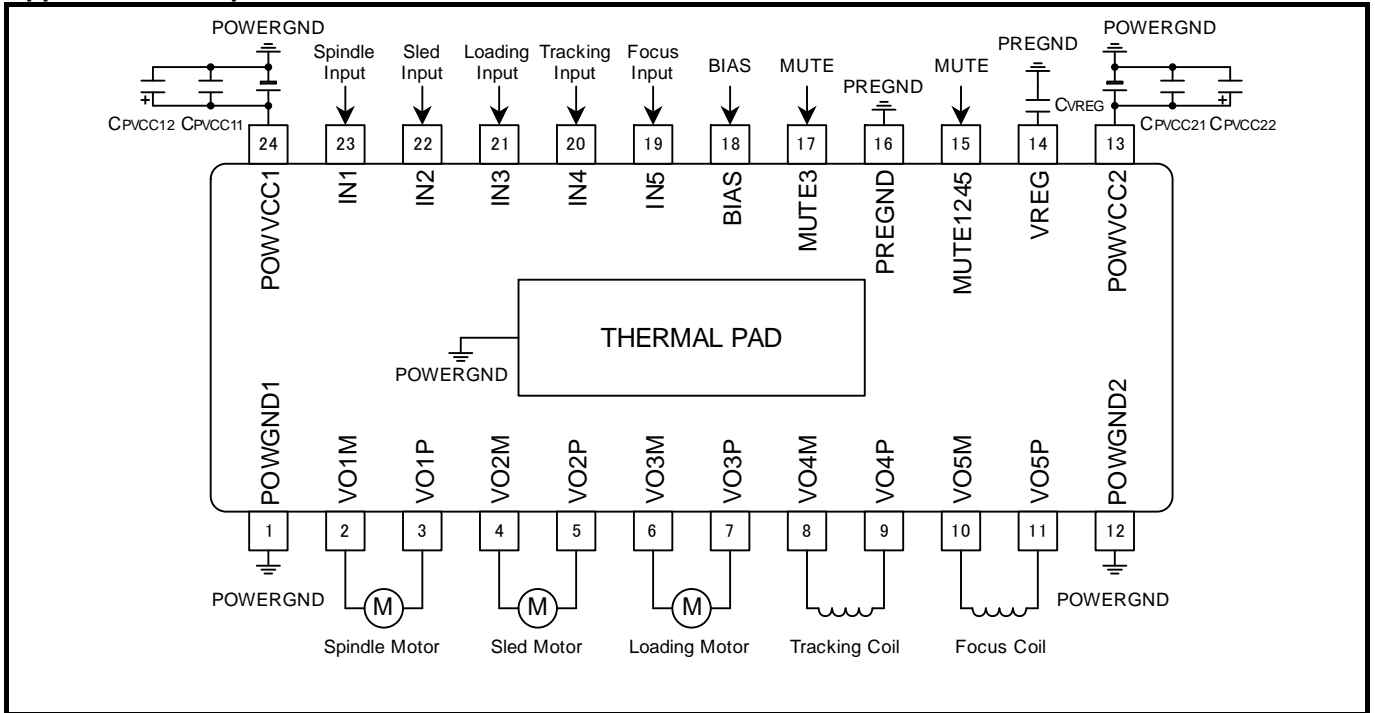

Figure 15. Application Example

▼Channel setting example

CH1	Spindle
CH2	Sled
CH3	Loading
CH4	Tracking
CH5	Focus

▼External parts list

Component name	Component value	Product name	Manufacturer
CPVCC11	0.1μF	GCM188R11H104KA42	murata
CPVCC12	47μF	UCD1E470MCL	Nichicon
CPVCC21	0.1μF	GCM188R11H104KA42	murata
CPVCC22	47μF	UCD1E470MCL	Nichicon
CVREG	0.1μF	GCM188R11H104KA42	murata

Power Dissipation

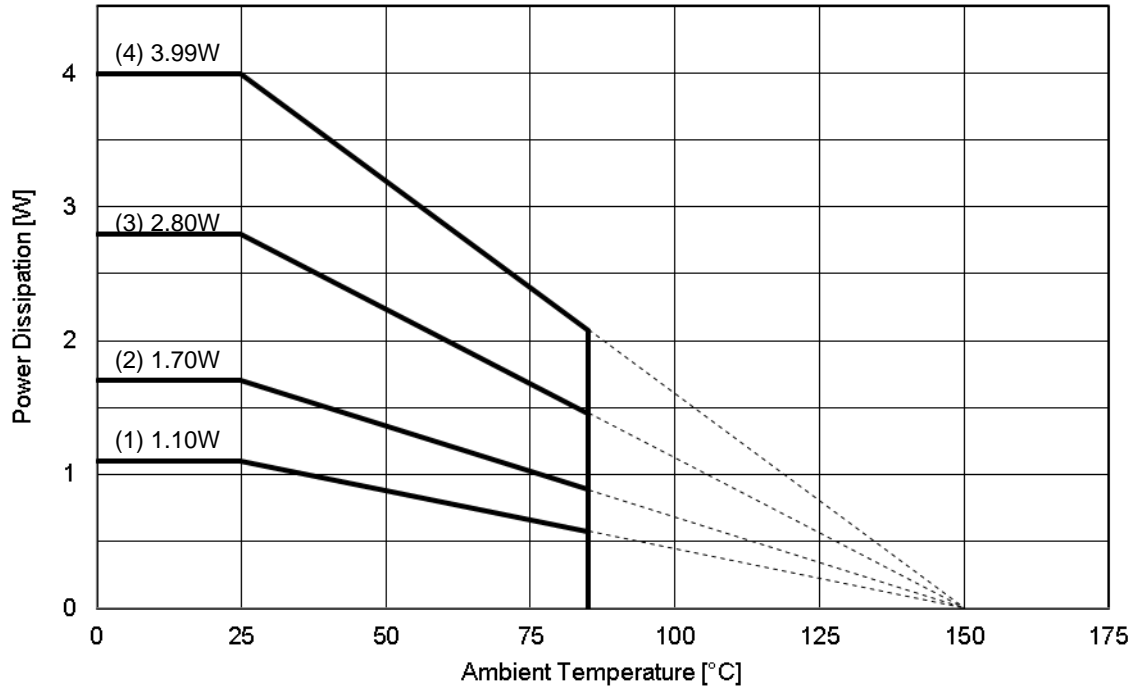

Figure 16. Power Dissipation

<Conditions>

- Power dissipation calculated when IC is mounted on a 70mm × 70mm × 1.6mm glass epoxy substrate. (Power dissipation changes with the copper foil density of the board.)
- The board and the IC's bottom thermal plate are solder-connected.

Board (1): 1-layer board (copper foil 0mm × 0mm)
 Board (2): 2-layer board (copper foil 15mm × 15mm)
 Board (3): 2-layer board (copper foil 70mm × 70mm)
 Board (4): 4-layer board (copper foil 70mm × 70mm)

Board (1): $\theta_{ja} = 113.6 \text{ }^\circ\text{C/W}$
 Board (2): $\theta_{ja} = 73.5 \text{ }^\circ\text{C/W}$
 Board (3): $\theta_{ja} = 44.6 \text{ }^\circ\text{C/W}$
 Board (4): $\theta_{ja} = 31.3 \text{ }^\circ\text{C/W}$

At $T_a=85^\circ\text{C}$:

Board (1): $P_d = 0.57\text{W}$
 Board (2): $P_d = 0.88\text{W}$
 Board (3): $P_d = 1.45\text{W}$
 Board (4): $P_d = 2.07\text{W}$

I/O Equivalence Circuits

<p>2.VO1M, 3.VO1P, 4.VO2M, 5.VO2P, 6.VO3M, 7.VO3P</p>	<p>8.VO4M, 9.VO4P, 10.VO5M, 11.VO5P</p>
<p>14.VREG</p>	<p>15.MUTE1245, 17.MUTE3</p>
<p>18.BIAS</p>	<p>19.IN5, 20.IN4</p>
<p>21.IN3, 22.IN2, 23.IN1</p>	

※Values is typical.

Operational Notes

1. Reverse Connection of Power Supply

Connecting the power supply in reverse polarity can damage the IC. Take precautions against reverse polarity when connecting the power supply, such as mounting an external diode between the power supply and the IC's power supply pins.

2. Power Supply Lines

Design the PCB layout pattern to provide low impedance supply lines. Separate the ground and supply lines of the digital and analog blocks to prevent noise in the ground and supply lines of the digital block from affecting the analog block. Furthermore, connect a capacitor to ground at all power supply pins. Consider the effect of temperature and aging on the capacitance value when using electrolytic capacitors.

3. Ground Voltage

Ensure that no pins are at a voltage below that of the ground pin at any time, even during transient condition. However, pins that drive inductive loads (e.g. motor driver outputs, DC-DC converter outputs) may inevitably go below ground due to back EMF or electromotive force. In such cases, the user should make sure that such voltages going below ground will not cause the IC and the system to malfunction by examining carefully all relevant factors and conditions such as motor characteristics, supply voltage, operating frequency and PCB wiring to name a few.

4. Ground Wiring Pattern

When using both small-signal and large-current ground traces, the two ground traces should be routed separately but connected to a single ground at the reference point of the application board to avoid fluctuations in the small-signal ground caused by large currents. Also ensure that the ground traces of external components do not cause variations on the ground voltage. The ground lines must be as short and thick as possible to reduce line impedance.

5. Thermal Consideration

Should by any chance the power dissipation rating (Pd) be exceeded, the rise in temperature of the chip may result in deterioration of the properties of the chip. The absolute maximum rating of Pd stated in this specification is when the IC is mounted on a 70mm x 70mm x 1.6mm glass epoxy board. To prevent exceeding the power dissipation rating, increase the board size and copper area.

6. Recommended Operating Conditions

These conditions represent a range within which the expected characteristics of the IC can be approximately obtained. The electrical characteristics are guaranteed under the conditions of each parameter.

7. Inrush Current

When power is first supplied to the IC, it is possible that the internal logic may be unstable and inrush current may flow instantaneously due to the internal powering sequence and delays, especially if the IC has more than one power supply. Therefore, give special consideration to power coupling capacitance, power wiring, width of ground wiring, and routing of connections.

8. Operation Under Strong Electromagnetic Field

Operating the IC in the presence of a strong electromagnetic field may cause the IC to malfunction.

9. Testing on Application Boards

When testing the IC on an application board, connecting a capacitor directly to a low-impedance output pin may subject the IC to stress. Always discharge capacitors completely after each process or step. The IC's power supply should always be turned off completely before connecting or removing it from the test setup during the inspection process. To prevent damage from static discharge, ground the IC during assembly and use similar precautions during transport and storage.

10. Inter-pin Short and Mounting Errors

Ensure that the direction and position are correct when mounting the IC on the PCB. Incorrect mounting may result in damaging the IC. Avoid nearby pins being shorted to each other especially to ground, power supply and output pin. Inter-pin shorts could be due to many reasons such as metal particles, water droplets (in very humid environment) and unintentional solder bridge deposited in between pins during assembly to name a few.

Operational Notes – continued

11. Unused Input Pins

Input pins of an IC are often connected to the gate of a MOS transistor. The gate has extremely high impedance and extremely low capacitance. If left unconnected, the electric field from the outside can easily charge it. The small charge acquired in this way is enough to produce a significant effect on the conduction through the transistor and cause unexpected operation of the IC. Unless otherwise specified, unused input pins should be connected to the power supply or ground line.

12. Regarding the Input Pin of the IC

This monolithic IC contains P+ isolation and P substrate layers between adjacent elements in order to keep them isolated. P-N junctions are formed at the intersection of the P layers with the N layers of other elements, creating a parasitic diode or transistor. For example (refer to figure below):

When $GND > Pin A$ and $GND > Pin B$, the P-N junction operates as a parasitic diode.
When $GND > Pin B$, the P-N junction operates as a parasitic transistor.

Parasitic diodes inevitably occur in the structure of the IC. The operation of parasitic diodes can result in mutual interference among circuits, operational faults, or physical damage. Therefore, conditions that cause these diodes to operate, such as applying a voltage lower than the GND voltage to an input pin (and thus to the P substrate) should be avoided.

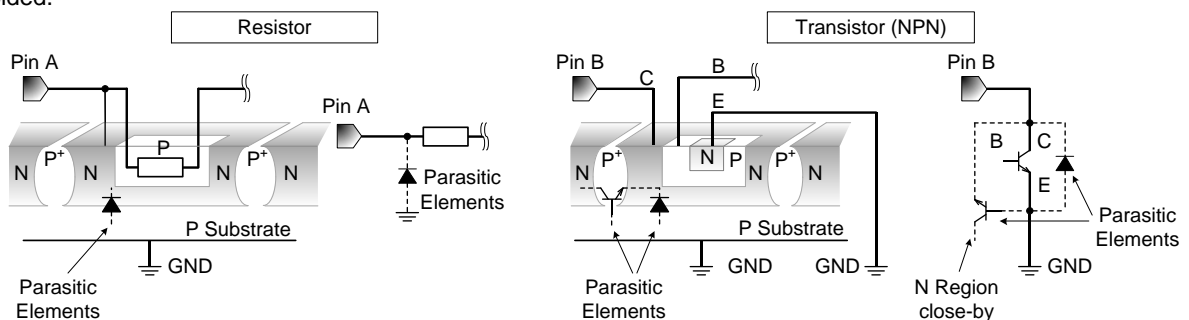

Figure 17. Example of monolithic IC structure

13. Ceramic Capacitor

When using a ceramic capacitor, determine the dielectric constant considering the change of capacitance with temperature and the decrease in nominal capacitance due to DC bias and others.

14. Area of Safe Operation (ASO)

Operate the IC such that the output voltage, output current, and power dissipation are all within the Area of Safe Operation (ASO).

15. Thermal Shutdown Circuit(TSD)

This IC has a built-in thermal shutdown circuit that prevents heat damage to the IC. Normal operation should always be within the IC's power dissipation rating. If however the rating is exceeded for a continued period, the junction temperature (T_j) will rise which will activate the TSD circuit that will turn OFF all output pins. When the T_j falls below the TSD threshold, the circuits are automatically restored to normal operation.

Note that the TSD circuit operates in a situation that exceeds the absolute maximum ratings and therefore, under no circumstances, should the TSD circuit be used in a set design or for any purpose other than protecting the IC from heat damage.

Ordering Information

B D 8 2 0 5 E F V	-	M E 2
Part Number	Package EFV : HTSSOP-B24	Packaging and forming specification M : High reliability E2 : Embossed tape and reel (HTSSOP-B24)

Marking Diagram

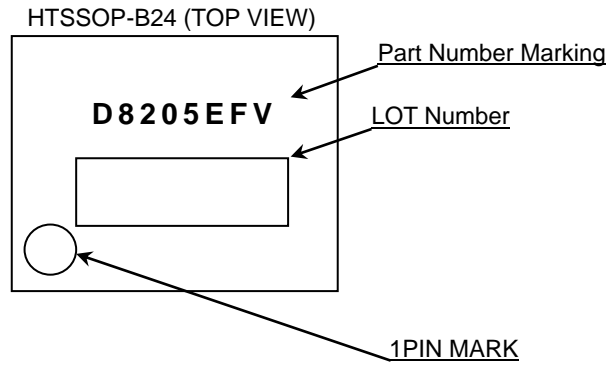

Physical Dimension, Tape and Reel Information

Package Name	HTSSOP-B24
--------------	------------

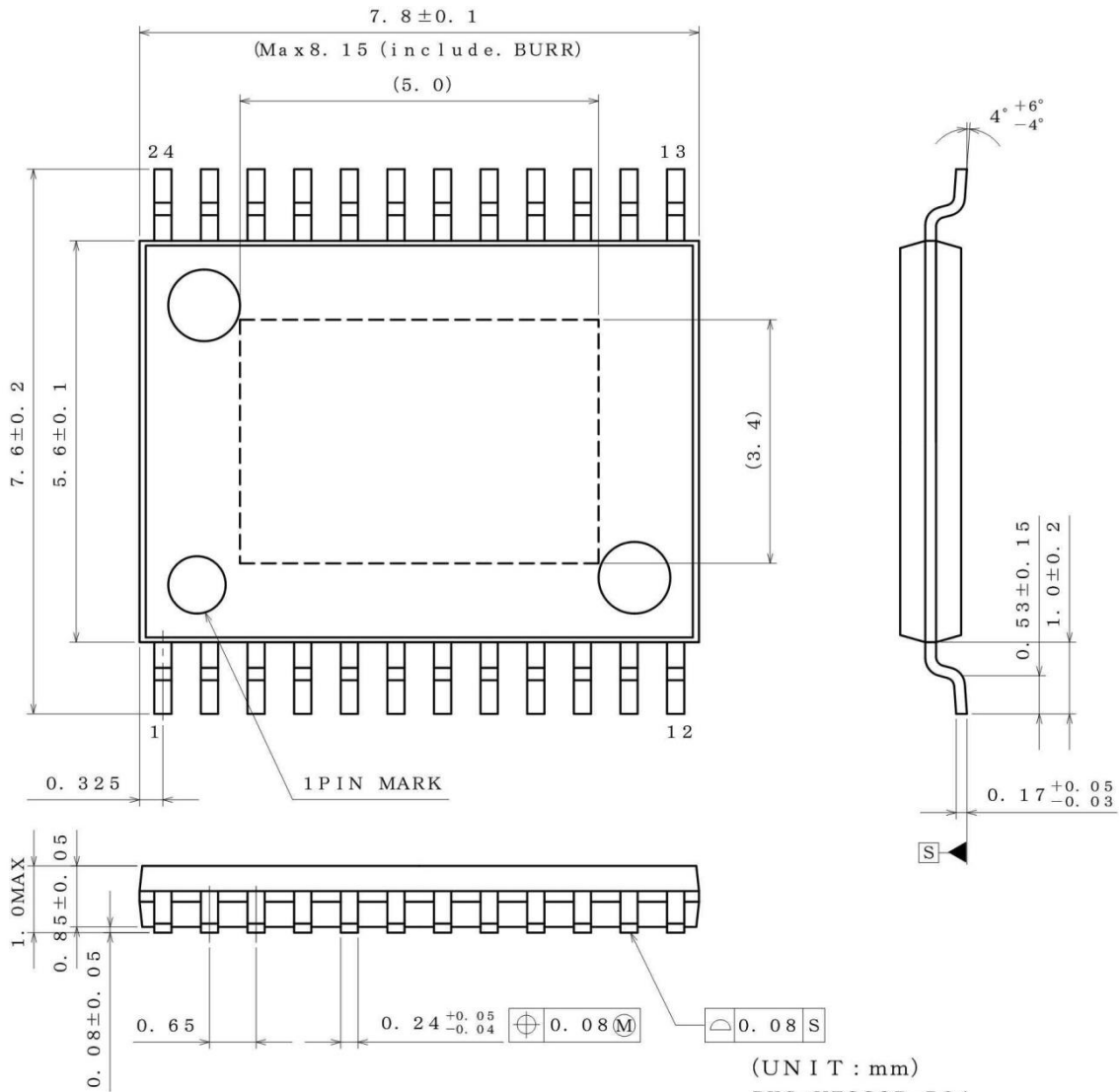

(UNIT : mm)
 PKG : HTSSOP-B24
 Drawing No. EX191-5002-1

<Tape and Reel information>

Tape	Embossed carrier tape (with dry pack)
Quantity	2000pcs
Direction of feed	E2 (The direction is the 1pin of product is at the upper left when you hold reel on the left hand and you pull out the tape on the right hand)

1pin
 *Order quantity needs to be multiple of the minimum quantity.

Revision History

Date	Revision	Changes
04.Dec.2014	001	New Release

Notice

Precaution on using ROHM Products

1. If you intend to use our Products in devices requiring extremely high reliability (such as medical equipment ^(Note 1), aircraft/spacecraft, nuclear power controllers, etc.) and whose malfunction or failure may cause loss of human life, bodily injury or serious damage to property ("Specific Applications"), please consult with the ROHM sales representative in advance. Unless otherwise agreed in writing by ROHM in advance, ROHM shall not be in any way responsible or liable for any damages, expenses or losses incurred by you or third parties arising from the use of any ROHM's Products for Specific Applications.

(Note1) Medical Equipment Classification of the Specific Applications

JAPAN	USA	EU	CHINA
CLASS III	CLASS III	CLASS II b	CLASS III
CLASS IV		CLASS III	

2. ROHM designs and manufactures its Products subject to strict quality control system. However, semiconductor products can fail or malfunction at a certain rate. Please be sure to implement, at your own responsibilities, adequate safety measures including but not limited to fail-safe design against the physical injury, damage to any property, which a failure or malfunction of our Products may cause. The following are examples of safety measures:
 - [a] Installation of protection circuits or other protective devices to improve system safety
 - [b] Installation of redundant circuits to reduce the impact of single or multiple circuit failure
3. Our Products are not designed under any special or extraordinary environments or conditions, as exemplified below. Accordingly, ROHM shall not be in any way responsible or liable for any damages, expenses or losses arising from the use of any ROHM's Products under any special or extraordinary environments or conditions. If you intend to use our Products under any special or extraordinary environments or conditions (as exemplified below), your independent verification and confirmation of product performance, reliability, etc. prior to use, must be necessary:
 - [a] Use of our Products in any types of liquid, including water, oils, chemicals, and organic solvents
 - [b] Use of our Products outdoors or in places where the Products are exposed to direct sunlight or dust
 - [c] Use of our Products in places where the Products are exposed to sea wind or corrosive gases, including Cl₂, H₂S, NH₃, SO₂, and NO₂
 - [d] Use of our Products in places where the Products are exposed to static electricity or electromagnetic waves
 - [e] Use of our Products in proximity to heat-producing components, plastic cords, or other flammable items
 - [f] Sealing or coating our Products with resin or other coating materials
 - [g] Use of our Products without cleaning residue of flux (even if you use no-clean type fluxes, cleaning residue of flux is recommended); or Washing our Products by using water or water-soluble cleaning agents for cleaning residue after soldering
 - [h] Use of the Products in places subject to dew condensation
4. The Products are not subject to radiation-proof design.
5. Please verify and confirm characteristics of the final or mounted products in using the Products.
6. In particular, if a transient load (a large amount of load applied in a short period of time, such as pulse. is applied, confirmation of performance characteristics after on-board mounting is strongly recommended. Avoid applying power exceeding normal rated power; exceeding the power rating under steady-state loading condition may negatively affect product performance and reliability.
7. De-rate Power Dissipation depending on ambient temperature. When used in sealed area, confirm that it is the use in the range that does not exceed the maximum junction temperature.
8. Confirm that operation temperature is within the specified range described in the product specification.
9. ROHM shall not be in any way responsible or liable for failure induced under deviant condition from what is defined in this document.

Precaution for Mounting / Circuit board design

1. When a highly active halogenous (chlorine, bromine, etc.) flux is used, the residue of flux may negatively affect product performance and reliability.
2. In principle, the reflow soldering method must be used on a surface-mount products, the flow soldering method must be used on a through hole mount products. If the flow soldering method is preferred on a surface-mount products, please consult with the ROHM representative in advance.

For details, please refer to ROHM Mounting specification

Precautions Regarding Application Examples and External Circuits

1. If change is made to the constant of an external circuit, please allow a sufficient margin considering variations of the characteristics of the Products and external components, including transient characteristics, as well as static characteristics.
2. You agree that application notes, reference designs, and associated data and information contained in this document are presented only as guidance for Products use. Therefore, in case you use such information, you are solely responsible for it and you must exercise your own independent verification and judgment in the use of such information contained in this document. ROHM shall not be in any way responsible or liable for any damages, expenses or losses incurred by you or third parties arising from the use of such information.

Precaution for Electrostatic

This Product is electrostatic sensitive product, which may be damaged due to electrostatic discharge. Please take proper caution in your manufacturing process and storage so that voltage exceeding the Products maximum rating will not be applied to Products. Please take special care under dry condition (e.g. Grounding of human body / equipment / solder iron, isolation from charged objects, setting of Ionizer, friction prevention and temperature / humidity control).

Precaution for Storage / Transportation

1. Product performance and soldered connections may deteriorate if the Products are stored in the places where:
 - [a] the Products are exposed to sea winds or corrosive gases, including Cl₂, H₂S, NH₃, SO₂, and NO₂
 - [b] the temperature or humidity exceeds those recommended by ROHM
 - [c] the Products are exposed to direct sunshine or condensation
 - [d] the Products are exposed to high Electrostatic
2. Even under ROHM recommended storage condition, solderability of products out of recommended storage time period may be degraded. It is strongly recommended to confirm solderability before using Products of which storage time is exceeding the recommended storage time period.
3. Store / transport cartons in the correct direction, which is indicated on a carton with a symbol. Otherwise bent leads may occur due to excessive stress applied when dropping of a carton.
4. Use Products within the specified time after opening a humidity barrier bag. Baking is required before using Products of which storage time is exceeding the recommended storage time period.

Precaution for Product Label

A two-dimensional barcode printed on ROHM Products label is for ROHM's internal use only.

Precaution for Disposition

When disposing Products please dispose them properly using an authorized industry waste company.

Precaution for Foreign Exchange and Foreign Trade act

Since concerned goods might be fallen under listed items of export control prescribed by Foreign exchange and Foreign trade act, please consult with ROHM in case of export.

Precaution Regarding Intellectual Property Rights

1. All information and data including but not limited to application example contained in this document is for reference only. ROHM does not warrant that foregoing information or data will not infringe any intellectual property rights or any other rights of any third party regarding such information or data.
2. ROHM shall not have any obligations where the claims, actions or demands arising from the combination of the Products with other articles such as components, circuits, systems or external equipment (including software).
3. No license, expressly or implied, is granted hereby under any intellectual property rights or other rights of ROHM or any third parties with respect to the Products or the information contained in this document. Provided, however, that ROHM will not assert its intellectual property rights or other rights against you or your customers to the extent necessary to manufacture or sell products containing the Products, subject to the terms and conditions herein.

Other Precaution

1. This document may not be reprinted or reproduced, in whole or in part, without prior written consent of ROHM.
2. The Products may not be disassembled, converted, modified, reproduced or otherwise changed without prior written consent of ROHM.
3. In no event shall you use in any way whatsoever the Products and the related technical information contained in the Products or this document for any military purposes, including but not limited to, the development of mass-destruction weapons.
4. The proper names of companies or products described in this document are trademarks or registered trademarks of ROHM, its affiliated companies or third parties.

General Precaution

1. Before you use our Products, you are requested to carefully read this document and fully understand its contents. ROHM shall not be in any way responsible or liable for failure, malfunction or accident arising from the use of any ROHM's Products against warning, caution or note contained in this document.
2. All information contained in this document is current as of the issuing date and subject to change without any prior notice. Before purchasing or using ROHM's Products, please confirm the latest information with a ROHM sales representative.
3. The information contained in this document is provided on an "as is" basis and ROHM does not warrant that all information contained in this document is accurate and/or error-free. ROHM shall not be in any way responsible or liable for any damages, expenses or losses incurred by you or third parties resulting from inaccuracy or errors of or concerning such information.

Looking for pricing, stock, or lifecycle information?

Click below to explore more details on WIN SOURCE:

- ⊖ [View BD8205EFV-ME2 on WIN SOURCE](#)
- ⊖ [Rohm Semiconductor](#) Information

Optimize Your Supply Chain with WIN SOURCE Solutions

- ✓ Global Sourcing Solution
- ✓ Obsolete Management
- ✓ Cost Control Management
- ✓ Shortage Management
- ✓ Alternative Solution
- ✓ Excess Inventory Management