



**THE DATASHEET OF
BD63920MUV-E2**



36V High-performance, High-reliability Withstand Voltage Stepping Motor Driver

BD63920MUV

General Description

BD63920MUV is a bipolar low-consumption driver that driven by PWM current. Rated power supply voltage of the device is 36 V, and rated output current is 2.0 A. CLK-IN and PARA-IN driving mode is adopted for input interface, and excitation mode is corresponding to FULL STEP mode (2 kinds), HALF STEP mode (3 kinds), QUARTER STEP mode (2 kinds), 1/8 step mode and 1/16 step mode via a built-in DAC. In terms of current decay, the FAST DECAY/SLOW DECAY ratio may be set without any limitation, and all available modes may be controlled in the most appropriate way. In addition, the power supply may be driven by one single system, which simplifies the design.

Features

- Rated output current (DC) 2.0A
- Low ON resistance DMOS output
- CLK-IN and PARA-IN drive mode
- PWM constant current (other oscillation)
- Built-in spike noise cancel function (external noise filter is unnecessary)
- Full (two kinds)-, half (three kinds)-, quarter (two kinds)-, 1/8-, 1/16-step functionality
- Freely timing excitation mode switch
- Current decay mode switch (linearly variable FAST/SLOW DECAY ratio)
- Normal rotation & reverse rotation switching function
- Power save function
- Built-in logic input pull-down resistor
- Power-on reset function
- Thermal shutdown circuit (TSD)
- Over-current protection circuit (OCP)
- Under voltage lock out circuit (UVLO)
- Over voltage lock out circuit (OVLO)
- Ghost Supply Prevention (protects against malfunction when power supply is disconnected)
- Adjacent pins short protection
- Microminiature, ultra-thin and high heat-radiation (exposed metal type) package

Application

- PPC, multi-function printer, laser beam printer, and ink-jet printer
- Monitoring camera and WEB camera
- Sewing machine
- Photo printer, FAX, scanner and mini printer
- Toy and robot

Key Specifications

- Range of power supply voltage 8~28 [V]
- Rated output current (continuous) 2.0 [A]
- Rated output current (peak value) 2.5 [A]
- Range of operating temperature -25~+85 [°C]
- Output ON resistance (total of upper and lower resistors) 0.49 [Ω] (Typ)

Package

VQFN028V5050

W(Typ) x D(Typ) x H(Max)

5.00mm x 5.00mm x 1.00mm

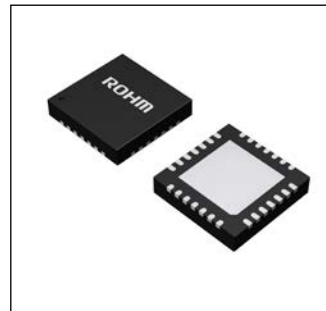

VQFN028V5050

Typical Application Circuit

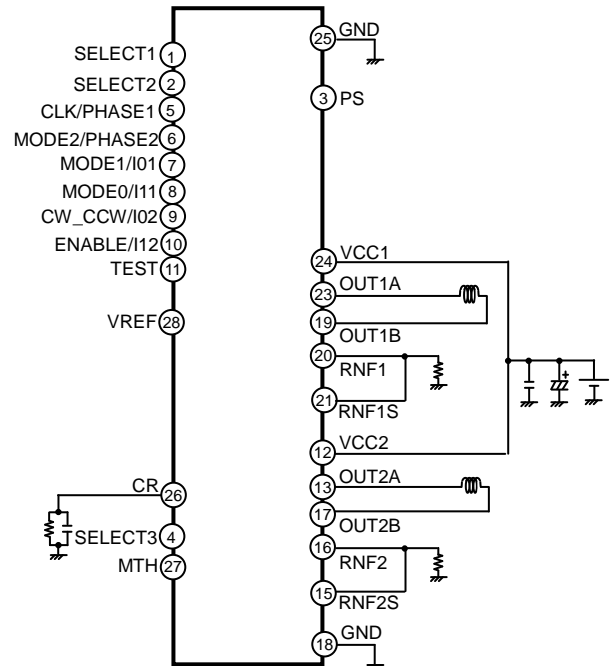

Figure 1. Application circuit diagram

Pin Configuration

[TOP VIEW]

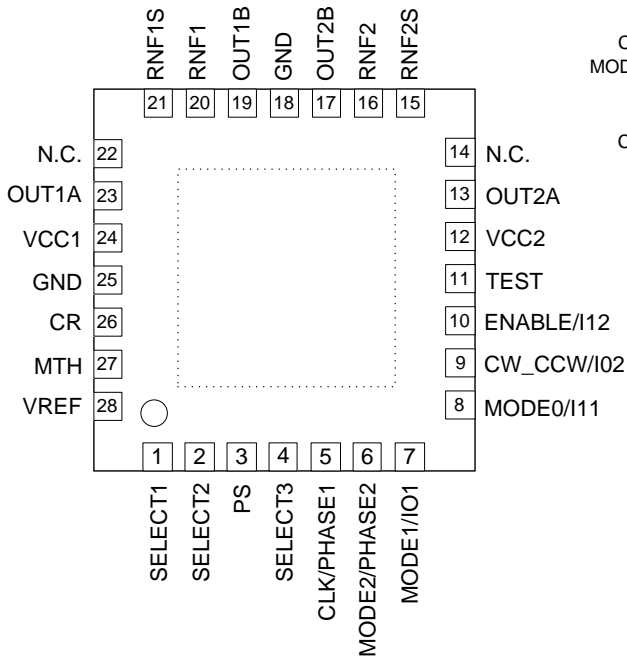

Figure 2. Pin Configuration Diagram

Block Diagram

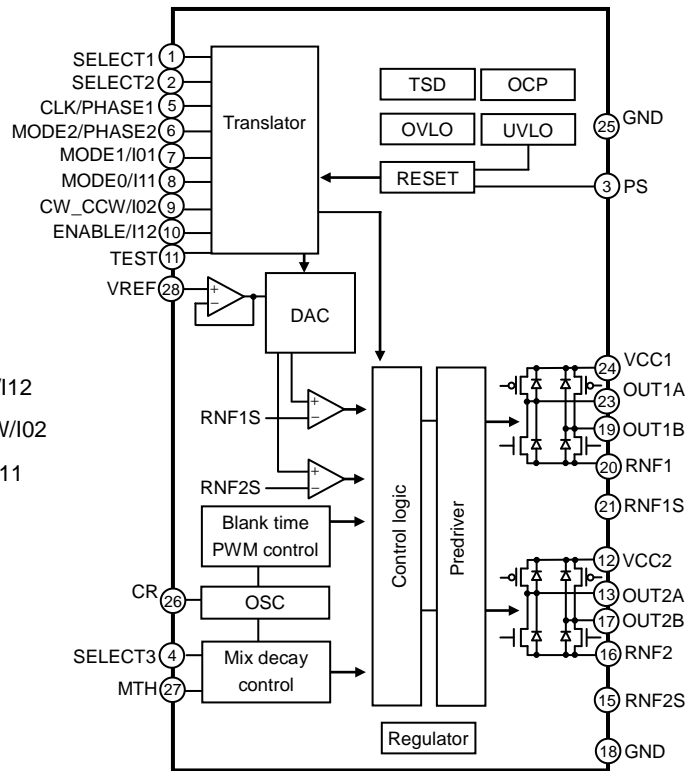

Figure 3. Block Diagram

Pin Description

Pin No.	Pin name (CLK/PARA)	Function (CLK / PARA IN)	Pin No.	Pin name (CLK/PARA)	Function (CLK / PARA IN)
1	SELECT1	Drive mode setting terminal	15	RNF2S	Input terminal of current limit comparator
2	SELECT2	Motor excitation mode setting terminal	16	RNF2	Connection terminal of resistor for output current detection
3	PS	Power save terminal	17	OUT2B	H bridge output terminal
4	SELECT3	Decay mode setting terminal	18	GND	Ground terminal
5	CLK /PHASE1	Clock input terminal for advancing the electrical angle. /Phase selection terminal	19	OUT1B	H bridge output terminal
6	MODE2 /PHASE2	Motor excitation mode setting terminal /Phase selection terminal	20	RNF1	Connection terminal of resistor for output current detection
7	MODE1 /IO1	Motor excitation mode setting terminal /VREF division ratio setting terminal	21	RNF1S	Input terminal of current limit comparator
8	MODE0 /I11	Motor excitation mode setting terminal /VREF division ratio setting terminal	22	N.C.	No Connection
9	CW_CCW /IO2	Motor rotating direction setting terminal /VREF division ratio setting terminal	23	OUT1A	H bridge output terminal
10	ENABLE /I12	Output enable terminal /VREF division ratio setting terminal	24	VCC1	Power supply terminal
11	TEST	Terminal for testing (Used by connecting with GND)	25	GND	Ground terminal
12	VCC2	Power supply terminal	26	CR	Connection terminal of CR for setting chopping frequency
13	OUT2A	H bridge output terminal	27	MTH	Current decay mode setting terminal
14	N.C.	No Connection	28	VREF	Output current value setting terminal

Description of operation

○ SELECT1 / Input Mode Switching Terminal

This is the terminal to set the input mode.

SELECT1	Drive Mode
L	CLK-IN
H	Parallel-IN

○ SELECT3 / Input Mode Switching Terminal

This is the terminal to set the input mode.

SELECT3	DECAY Mode
L	DECAY Mode 1
H	DECAY Mode 2

● **Input mode in the case of CLK-IN drive (SELECT1=L)**

○ CLK / Clock input terminal for advancing the electrical angle

CLK is reflected at rising edge. The Electrical angle advances by one for each CLK input.

Motor's misstep will occur if noise is picked up at the CLK terminal, so please design the pattern in such a way that there is no noise plunging

○ MODE0,MODE1,MODE2,SELECT2 / Motor Excitation Mode Setting Terminal (SELECT1=L)

Set the motor excitation mode

MODE0	MODE1	MODE2	SELECT2	Excitation Mode
L	L	L	X	FULL STEP A
H	L	L	X	HALF STEP A
L	H	L	X	HALF STEP B
H	H	L	X	QUARTER STEP A
L	L	H	X	FULL STEP B
H	L	H	X	HALF STEP C
L	H	H	X	QUARTER STEP B
H	H	H	L	1/8 STEP
H	H	H	H	1/16 STEP

※X : L or H

Please refer to the P.14-18 for the timing chart & motor torque vector of various excitation modes. Unrelated to CLK, change in setting is forcibly reflected (refer to P.20).

○ CW_CCW / Motor rotating direction setting

Set the motor's rotating direction. Change in setting is reflected at the CLK rising edge immediately after the change in setting (refer to P.19)

CW_CCW	Rotating direction
L	Clockwise (CH2's current is outputted with a phase lag of 90° in regard to CH1's current)
H	Counter Clockwise (CH2's current is outputted with a phase lead of 90° in regard to CH1's current)

○ ENABLE / Output enable terminal

Turn off forcibly all the output transistors (motor output is open).

When ENABLE=L, input to CLK is blocked, and phase advance operation of internal translator circuit is stopped.

However, during excitation modes (MODE0,MODE1,MODE2,SELECT2) switch within the interval of ENABLE=L, as ENABLE=L→H is reset, the new mode upon switch will be applied for excitation (refer to P.20).

ENABLE	Motor Output
L	OPEN (electrical angle maintained)
H	ACTIVE

○PS/Power save terminal

PS can make circuit standby state and make motor output OPEN. In standby state, translator circuit is reset (initialized) and electrical angle is initialized.

Please be careful because there is a delay of 40μs(max.) before it is returned from standby state to normal state and the motor output becomes ACTIVE (refer to P.13).

PS	Status
L	Standby state(RESET)
H	ACTIVE

The electrical angle (initial electrical angle) of each excitation mode immediately after RESET is as follows (refer to P.14-16).

Excitation Mode	Initial Electrical Angle
FULL STEP A	45°
HALF STEP A	45°
HALF STEP B	45°
QUARTER STEP A	45°
FULL STEP B	45°
HALF STEP C	45°
QUARTER STEP B	45°
1/8 STEP	45°
1/16 STEP	45°

● Input mode in the case of Parallel-IN drive (SELECT1=H)

○PS/Power Save Terminal

Setting PS=L will cause the circuit to enter standby state and make motor output OPEN. In standby state, translator circuit, and electrical angle are initialized. Please take note that there is a delay of 40μs (max) before returning from standby state to normal state then the motor output becomes ACTIVE.

PS	Status
L	Standby state(RESET)
H	ACTIVE

○PHASE1,PHASE2/Phase selection terminal

PHASE1	PHASE2	OUT1A	OUT1B	OUT2A	OUT2B
L	L	L	H	L	H
H	L	H	L	L	H
L	H	L	H	H	L
H	H	H	L	H	L

○I01,I02,I11,I12/VREF division ratio setting terminal

I0x	I1x	Output current level(%)
L	L	100
H	L	67
L	H	33
H	H	0

(I0X, I1X)=(H, H): motor outputs are open.

○VCC1,VCC2 / Power supply terminal

Motor's drive current is flowing in it, so please wire in such a way that the wire is thick & short and has low impedance. Voltage VCC may have great fluctuation, so please arrange the bypass capacitor of about $100\mu\sim 470\mu\text{F}$ as close to the terminal as possible and adjust in such a way that the voltage VCC is stable. Please increase the capacity if needed especially when a large current is used or those motors that have great back electromotive force are used. In addition, for the purpose of reducing of power supply's impedance in wide frequency bandwidth, parallel connection of multi-layered ceramic capacitor of $0.01\mu\sim 0.1\mu\text{F}$ etc is recommended. Extreme care must be used to make sure that the voltage VCC does not exceed the rating even for a moment. VCC1 & VCC2 are shorted inside IC, so please be sure to short externally VCC1 & VCC2 when using. If used without shorting, malfunction or destruction may occur because of concentration of current routes etc., so please make sure that they are shorted when in use. Still more, in the power supply terminal, there is built-in clamp component for preventing of electrostatic destruction. If steep pulse or voltage of surge more than maximum absolute rating is applied, this clamp component operates, as a result there is the danger of destruction, so please be sure that the maximum absolute rating must not be exceeded. It is effective to mount a Zener diode of about the maximum absolute rating. Moreover, the diode for preventing of electrostatic destruction is inserted between VCC terminal and GND terminal, as a result there is the danger of IC destruction if reverse voltage is applied between VCC terminal and GND terminal, so please be careful.

○GND / Ground terminal

In order to reduce the noise caused by switching current and to stabilize the internal reference voltage of IC, please wire in such a way that the wiring impedance from this terminal is made as low as possible to achieve the lowest electrical potential no matter what operating state it may be.

○OUT1A,OUT1B,OUT2A,OUT2B / H Bridge output terminal

Motor's drive current is flowing in it, so please wire in such a way that the wire is thick & short and has low impedance. It is also effective to add a Schottky diode if output has positive or negative great fluctuation when large current is used etc, for example, if counter electromotive voltage etc. is great. Moreover, in the output terminal, there is built-in clamp component for preventing of electrostatic destruction. If steep pulse or voltage of surge more than maximum absolute rating is applied, this clamp component operates, as a result there is the danger of even destruction, so please be sure that the maximum absolute rating must not be exceeded.

○RNF1,RNF2 / Connection terminal of resistor for detecting of output current

Please connect the resistor of $0.1\Omega\sim 0.3\Omega$ for current detection between this terminal and GND. In view of the power consumption of the current-detecting resistor, please determine the resistor in such a way that $W=I_{\text{OUT}2}\cdot R[W]$ does not exceed the power dissipation of the resistor. In addition, please wire in such a way that it has a low impedance and does not have a impedance in common with other GND patterns because motor's drive current flows in the pattern through RNF terminal~current-detecting resistor~GND. Please do not exceed the rating because there is the possibility of circuits' malfunction etc. if RNF voltage has exceeded the maximum rating (0.7V). Moreover, please be careful because if RNF terminal is shorted to GND, large current flows without normal PWM constant current control, then there is the danger that OCP or TSD will operate. If RNF terminal is open, then there is the possibility of such malfunction as output current does not flow either, so please do not let it open.

○RNF1S,RNF2S / Input terminal of current limit comparator

In this series, RNFS terminal, which is the input terminal of current limit comparator, is independently arranged in order to decrease the lowering of current-detecting accuracy caused by the wire impedance inside the IC of RNF terminal. Therefore, please be sure to connect RNF terminal and RNFS terminal together when using in the case of PWM constant current control. In addition, because the wires from RNFS terminal is connected near the current-detecting resistor in the case of interconnection, the lowering of current-detecting accuracy, which is caused by the impedance of board pattern between RNF terminal and the current-detecting resistor, can be decreased. Moreover, please design the pattern in such a way that there is no noise plunging. In addition, please be careful because if terminals of RNF1S & RNF2S are shorted to GND, large current flows without normal PWM constant current control and, then there is the danger that OCP or TSD will operate.

○VREF / Output current value setting terminal

This is the terminal to set the output current value. The output current value can be set by VREF voltage and current-detecting resistor (RNF resistor).

Output current $I_{\text{OUT}}[A] = \{V_{\text{REF}}[V] / 5(\text{division ratio inside IC})\} / R_{\text{NF}}[\Omega] \dots$ (ALL step modes except Full Step B)

Output current $I_{\text{OUT}}[A] = \{V_{\text{REF}}[V] / 5(\text{division ratio inside IC})\} * 0.7071 / R_{\text{NF}}[\Omega] \dots$ (Full Step B)

Please avoid using it with VREF terminal open because if VREF terminal is open, the input is unsettled, and the VREF voltage increases, and then there is the possibility of such malfunctions as the setting current increases and a large current flows etc. Please keep to the input voltage range because if the voltage of over 3V is applied on VREF terminal, then there is also the danger that a large current flows in the output and so OCP or TSD will operate. Besides, please take into consideration the outflow current (max.2μA) if inputted by resistance division when selecting the resistance value. The minimum current, which can be controlled by VREF voltage, is determined by motor coil's L & R values and minimum ON time because there is a minimum ON time in PWM drive.

○CR/Connection terminal of CR for setting chopping frequency

This is the terminal to set the chopping frequency of output. Please connect the external C(470p~3300pF) and R(10k~200kΩ) between this terminal and GND. Please refer to P10.

Please interconnect from external components to GND in such a way that the interconnection does not have impedance in common with other GND patterns. In addition, please carry out the pattern design in such ways as keeps such steep pulses as square wave etc. away and that there is no noise plunging. Please mount the two components of C and R if being used by PWM constant current control because normal PWM constant current control becomes impossible if CR terminal is open or it is biased externally.

○MTH/Current decay mode-setting terminal

This is the terminal to set the current decay mode. Current decay mode can be optionally set according to input voltage.

MTH terminal input voltage[V]	Current decay mode
0~0.3	SLOW DECAY
0.4~1.0	MIX DECAY
1.5~3.5	FAST DECAY

Please connect to GND if using at SLOW DECAY mode.

Please avoid using with MTH terminal open because if MTH terminal is open, the input is unsettled, and then there is the danger that PWM operation becomes unstable. Besides, please take into consideration the outflow current (max.2μA) if inputted by resistance division when selecting the resistance value.

○TEST/Terminal for inspection

This terminal is used for delivery inspection on IC, and shall be grounded before use. In addition, malfunctions may be caused by application without grounding.

○NC terminal

This terminal is unconnected electrically with IC internal circuit.

○Thermal Shutdown (TSD)

This IC has a built-in thermal shutdown circuit for thermal protection.

When the IC's chip temperature rises above 175°C(Typ) the motor output becomes OPEN. Also, when the temperature returns to under 150°C(Typ), it automatically returns to normal operation. However, even when TSD is in operation, if heat is continued to be added externally, heat overdrive can lead to destruction.

○Over Current Protection (OCP)

This IC has a built in over current protection circuit as a provision against destruction when the motor outputs are shorted each other or VCC-motor output or motor output-GND is shorted. This circuit latches the motor output to OPEN condition when the regulated threshold current flows for 4μs (Typ). It returns with power reactivation or a reset of the PS terminal.

The over current protection circuit's only aim is to prevent the destruction of the IC from irregular situations such as motor output shorts, and is not meant to be used as protection or security for the set. Therefore, sets should not be designed to take into account this circuit's functions. After OCP operating, if irregular situations continues and the return by power reactivation or a reset of the PS terminal is carried out repeatedly, then OCP operates repeatedly and the IC may generate heat or otherwise deteriorate. When the L value of the wiring is great due to the wiring being long, after the over current has flowed and the output terminal voltage jumps up and the absolute maximum values may be exceeded and as a result, there is a possibility of destruction. Also, when current which is over the output current rating and under the OCP detection current flows, the IC can heat up to over $T_{jmax}=150^{\circ}\text{C}$ and can deteriorate, so current which exceeds the output rating should not be applied.

○Under Voltage Lock Out (UVLO)

This IC has a built-in under voltage lock out function to prevent false operation such as IC output during power supply under voltage. When the applied voltage to the VCC terminal goes under 5V (Typ), the motor output is set to OPEN.

This switching voltage has a 1V (Typ) hysteresis to prevent false operation by noise etc. Please be aware that this circuit does not operate during power save mode. Also, the electrical angle is reset when the UVLO circuit operates during CLK-IN drive mode.

○Over Voltage Lock Out (OVLO)

This IC has a built-in over voltage lock out function to protect the IC output and the motor during power supply over voltage. When the applied voltage to the VCC terminal goes over 32V (Typ), the motor output is set to OPEN.

This switching voltage has a 1V (Typ) hysteresis and a 4μs (Typ) mask time to prevent false operation by noise etc.

Although this over voltage locked out circuit is built-in, there is a possibility of destruction if the absolute maximum value for power supply voltage is exceeded, therefore the absolute maximum value should not be exceeded. Please be aware that this circuit does not operate during power save mode.

○Ghost Supply Prevention (protects against malfunction when power supply is disconnected)

If a signal (logic input, MTH, VREF) is input when there is no power supplied to this IC, there is a function which prevents the false operation by voltage supplied via the electrostatic destruction prevention diode from these input terminals to the VCC to this IC or to another IC's power supply. Therefore, there is no malfunction of the circuit even when voltage is supplied to these input terminals while there is no power supply.

oPWM Constant current control

1) Current control operation

When the output transistor is turned on, the output current increases, raising the voltage over the current sense resistor. When the voltage on the RNF pin reaches the voltage value set by the internal 2-bit/4-bit DAC and the VREF input voltage, the current limit comparator engages and enters current decay mode. The output is then held off for a period of time determined by the RC time constant connected to the CR pin. The process repeats itself constantly for PWM operation.

2) Noise-masking function

In order to avoid misdetection of output current due to RNF spikes that may occur when the output turns ON, the IC employs an automatic current detection-masking period during charging of CR (t_{ONMIN} 0.7 μ s Typ) and during change in internal PHASE (t_{ONMIN2} 1.5 μ s Typ: fixed in internal circuit), during which current detection is disabled immediately after the output transistor is turned on. This allows for constant-current drive without the need for an external filter. This noise-masking period defines the minimum ON-time for the motor output transistor.

3) CR Timer

The CR filter connected to the CR pin is repeatedly charged and discharged between the VCRH and VCRL levels. The output of the internal comparator is masked while charging from VCRL to VCRH in order to cancel noise. (As mentioned above, this period defines the minimum ON-time of the motor output transistor.) The CR terminal begins discharging once the voltage reaches VCRH. When the output current reaches the current limit during this period (i.e. RNF voltage reaches the decay trigger voltage), then the IC enters decay mode. The CR continues to discharge during this period until it reaches VCRL, at which point the IC output is switched back ON. The current output and CR pin begin charging simultaneously. The CR charge time (t_{ONMIN}) and discharge time ($t_{discharge}$) are set by external components, according to the following formulas. The total of t_{ONMIN} and $t_{discharge}$ yield the chopping period, t_{chop} .

$$t_{ONMIN}[s] \doteq C \cdot R' \cdot R / (R' + R) \cdot \ln[(VCR - 0.4)/(VCR - 1.0)]$$

$$VCR = V \cdot R / (R' + R)$$

V: internal regulator voltage 5V(Typ)

R': CR terminal internal impedance 5k Ω (Typ)

$$t_{discharge}[s] \doteq C \cdot R \cdot \ln[(1 + \alpha) / 0.4]$$

α : See the right graph.

$$t_{CHOP}[s] \doteq t_{ONMIN} + t_{discharge}$$

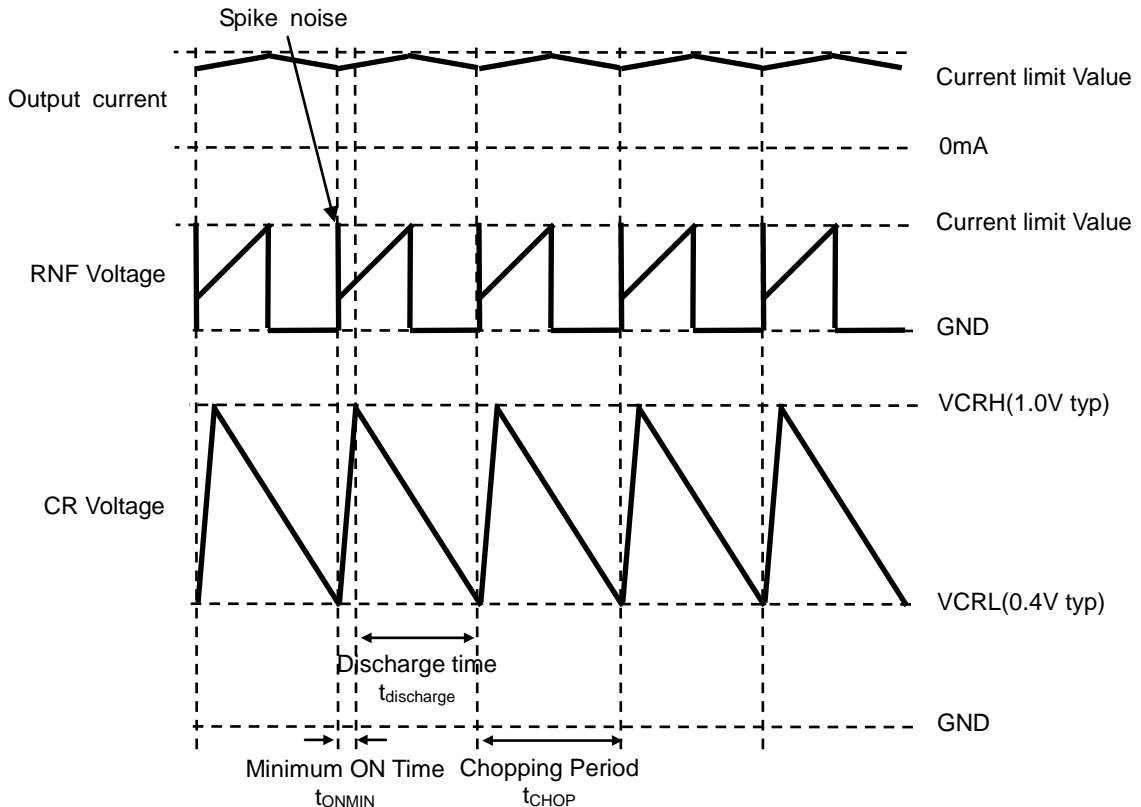
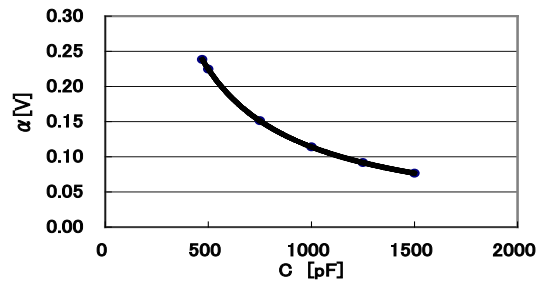

Figure 4 Timing chart of CR voltage, RNF voltage and output current

Attach a resistor of at least 10 k Ω to the CR terminal (10 k Ω ~200 k Ω recommended) as lower values may keep the RC from reaching the VCRH voltage level. A capacitor in the range of 470 pF – 3300 pF is also recommended. As the capacitance value is increased, however, the noise-masking period (t_{onmin}) also increases, and there is a risk that the output current may exceed the current limit threshold due to the internal L and R components of the output motor coil. Also, ensure that the chopping period (t_{chop}) is not set longer than necessary, as doing so will increase the output ripple, thereby decreasing the average output current and yielding lower output rotation efficiency. The optimal value should reduce the motor drive noise while keeping distortion of the output current waveform to a minimum.

○Current decay mode

The IC allows for a mixed decay mode in which the ratio of fast and slow decay can be optionally set.

The following diagrams show the operating state of each transistor and the regenerative current path during attenuation for each decay mode:

Input DECAY Mode 1 (SELECT3=L)

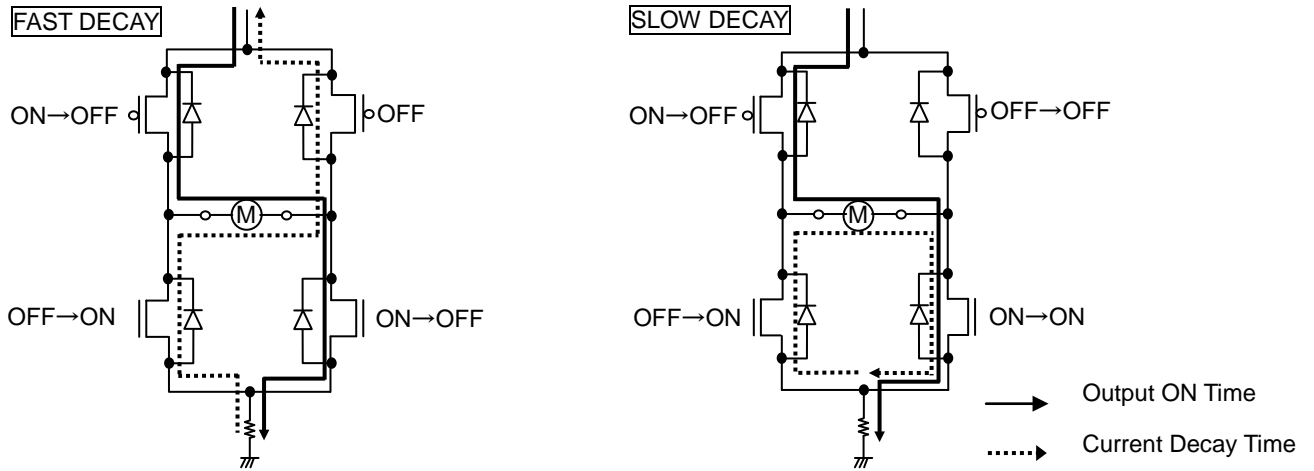

Figure 5. Route of Regenerated Current during Current Decay(DECAY Mode 1)

Input DECAY Mode 2 (SELECT3=H)

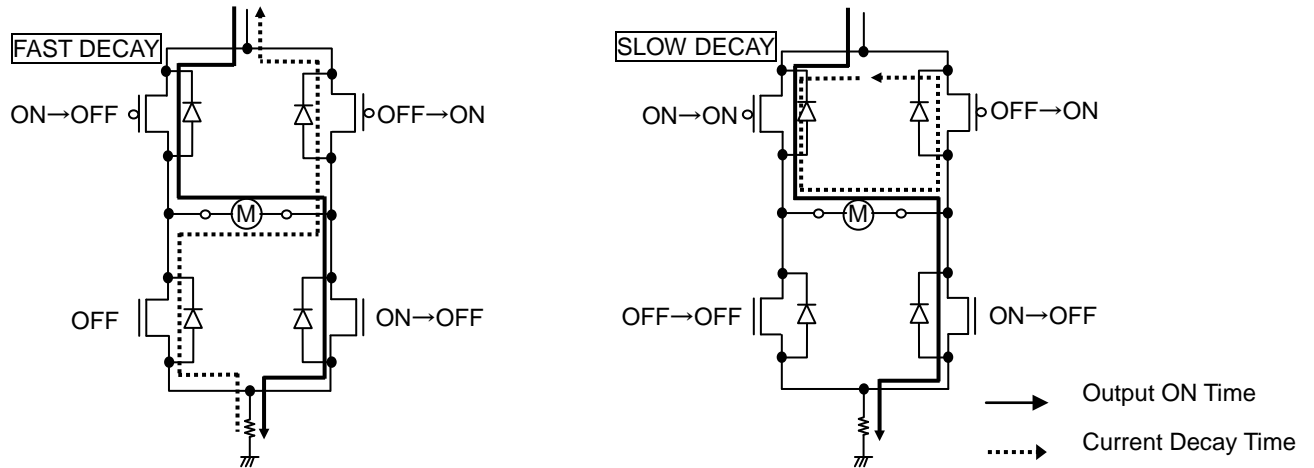

Figure 6. Route of Regenerated Current during Current Decay(DECAY Mode 2)

The merits of each decay mode are as follows:

○SLOW DECAY

During current attenuation, the voltage between motor coils is small and the regeneration current decreases slowly, decreasing the output current ripple. This is favorable for keeping motor torque high. However, due to fall-off of current control characteristics in the low-current region, or due to reverse EMF of the output motors exhibited when using high-pulse-rate half-step or quarter-step modes, the output current increases, distorting the output current waveform and increasing motor vibration. Thus, this decay mode is most suited to full-step modes, or low-pulse-rate half-step or quarter-step modes.

○FAST DECAY

Fast decay decreases the regeneration current much more quickly than slow decay, greatly reducing distortion of the output current waveform. However, fast decay yields a much larger output current ripple, which decreases the overall average current running through the motor. This causes two problems: first, the motor torque decreases (increasing the current limit value can help eliminate this problem, but the rated output current must be taken into consideration); and second, the power loss within the motor increases and thereby radiates more heat. If neither of these problems is of concern, then fast decay can be used for high-pulse rate half- or quarter-step drive.

Additionally, this IC allows for a mixed decay mode that can help improve upon problems that arise from using fast or slow decay alone. In this mode, the IC switches automatically between slow and fast decay, improving the current control characteristics without increasing the output current ripple. The ratio of fast to slow decay is set externally via the voltage input to the MTH pin; therefore, the optimal mix of slow and fast decay can be achieved for each application. Mixed decay mode operates by splitting the decay period into two sections, the first X%(t1-t2) of which operates the IC in slow decay mode, and the remainder(t2-t3) of which operates in fast decay mode. However, if the output current (i.e., the voltage on the RNF pin) does not reach the set current limit during the first X% (t1-t2) decay period, the IC operates in fast decay mode only.

MTH voltage [V]	Current decay mode
0~0.3	SLOW DECAY
0.4~1.0	MIX DECAY
1.5~3.5	FAST DECAY

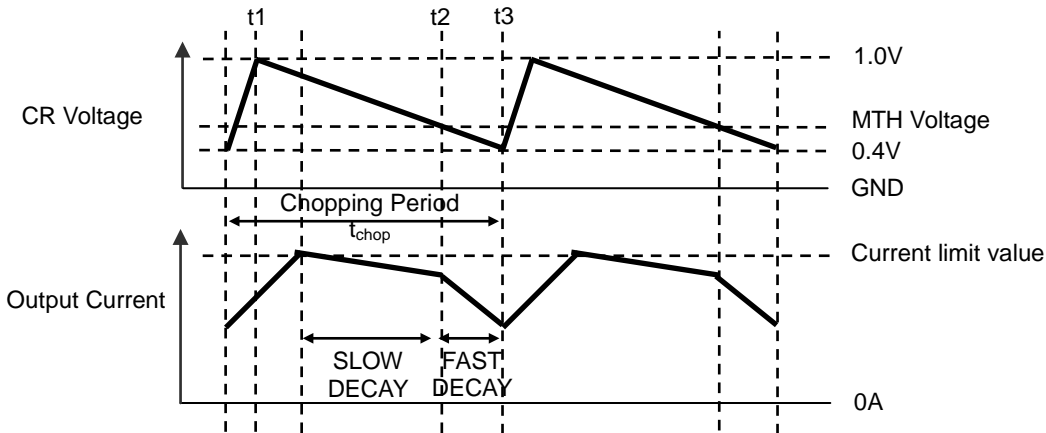

Figure 7. Relation between CR terminal voltage, MTH voltage, and output current during mixed decay

Absolute Maximum Ratings (Ta=25°C)

Item	Symbol	Rated Value	Unit
Supply voltage	V _{CC1,2}	-0.2~+36.0	V
Input voltage for control pin	V _{IN}	-0.2~+5.5	V
RNF maximum voltage	V _{RNF}	0.7	V
Maximum output current (DC)	I _{OUT}	2.0 ^{※3}	A/Phase
Maximum output current (Peak) ^{※4}	I _{OUTPEAK}	2.5 ^{※3}	A/Phase
Operating temperature range	T _{opr}	-25~+85	°C
Storage temperature range	T _{stg}	-55~+150	°C

※1 Derate by 3.04mW/°C when operating above Ta=25°C (IC only).

※2 4-layer recommended board. Derating is done at 36.5mW/°C for operating above Ta=25°C.

※3 Do not, however exceed Tjmax=150°C.

※4 Pulse width tw ≤ 1ms, duty 20%.

Caution: Operating the IC over the absolute maximum ratings may damage the IC. The damage can either be a short circuit between pins or an open circuit between pins and the internal circuitry. Therefore, it is important to consider circuit protection measures, such as adding a fuse, in case the IC is operated over the absolute maximum ratings.

Recommended Operating Conditions (Ta= -25~+85°C)

Item	Symbol	Rated Value	Unit
Supply voltage	V _{CC1,2}	8~28	V
Maximum Output current (DC)	I _{OUT}	1.7 ^{※5}	A/ Phase

※5 Not exceeding Tj=150°C.

Thermal Resistance^{※6}

Parameter	Symbol	Thermal Resistance (Typ)		Unit
		1s ^{※8}	2s2p ^{※9}	
VQFN028V5050				
Junction to Ambient	θ _{JA}	128.5	31.5	°C/W
Junction to Top Characterization Parameter ^{※7}	Ψ _{JT}	12	9	°C/W

※6 Based on JESD51-2A(Still-Air)

※7 The thermal characterization parameter to report the difference between junction temperature and the temperature at the top center of the outside surface of the component package.

※8 Using a PCB board based on JESD51-3

Layer Number of Measurement Board	Material	Board Size
Single	FR-4	114.3mm x 76.2mm x 1.57mmt
Top		
Copper Pattern	Thickness	
Footprints and Traces	70μm	

※9 Using a PCB board based on JESD51-7.

Layer Number of Measurement Board	Material	Board Size			
4 Layers	FR-4	114.3mm x 76.2mm x 1.6mmt			
Top		2 Internal Layers		Bottom	
Copper Pattern	Thickness	Copper Pattern	Thickness	Copper Pattern	Thickness
Footprints and Traces	70μm	74.2mm x 74.2mm	35μm	74.2mm x 74.2mm	70μm

Electrical Characteristics (Unless otherwise specified Ta=25°C, VCC1,2=24V)

Item	Symbol	Limit			Unit	Condition
		Min	Typ	Max		
[Whole]						
Circuit current at standby	I _{CCST}	-	-	10	μA	PS=L
Circuit current	I _{CC}	-	2.5	5.0	mA	PS=H, VREF=3V
[Control input]						
H-level input voltage	V _{INH}	2.0	-	-	V	
L-level input voltage	V _{INL}	-	-	0.8	V	
H-level input current	I _{INH}	35	50	100	μA	V _{IN} =5V
L-level input current	I _{INL}	-10	0	-	μA	V _{IN} =0V
[Output (OUT1A, OUT1B, OUT2A, OUT2B)]						
Output ON resistance	R _{ON}	-	0.49	0.75	Ω	I _{OUT} = ±1.5A (total of upper and lower resistors)
Output leak current	I _{LEAK}	-	-	10	μA	
[Current control]						
RNFxS input current	I _{RNFS}	-2.0	-0.1	-	μA	RNFxS=0V
RNFx input current	I _{RNF}	-80	-40	-	μA	RNFx=0V
VREF input current	I _{VREF}	-2.0	-0.1	-	μA	VREF=0V
VREF input voltage range	V _{VREF}	0	-	3.0	V	
MTH input current	I _{MTH}	-2.0	-0.1	-	μA	MTH=0V
MTH input voltage range	V _{MTH}	0	-	3.5	V	
Minimum ON time (Blank time)	t _{ONMIN}	0.3	0.7	1.5	μs	C=1000pF, R=39kΩ
Comparator threshold	V _{CTH}	0.57	0.60	0.63	V	VREF=3V

Timing Chart

Translator circuit

This series builds in translator circuit and can drive stepping motor in CLK-IN mode.

The operation of the translator circuit in CLK-IN drive mode is described as below.

○Reset operation

The translator circuit is initialized by power ON Reset function and PS terminal.

• Initializing operation when power supply is turned on

① If power supply is turned on at PS=L (Please use this sequence as a general rule)

When power supply is turned on, the power ON reset function operates in IC and initialized, but as long as it is PS=L, the motor output is the OPEN state. After power supply is turned on, because of the changing of PS=L⇒H, the motor output becomes the ACTIVE state, and the excitation is started at the initial electrical angle.

But at the time of PS=L⇒H, it returns from the standby state to the normal state and there is a delay of 40μs(max.) until the motor output has become the ACTIVE state.

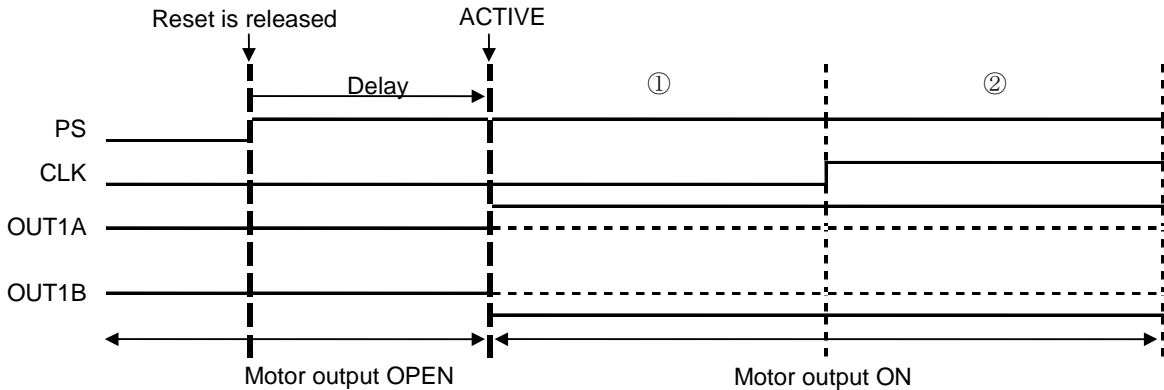

② If power supply is turned on at PS=H

When power supply is turned on, the power ON function in IC operates, and initialized before the motor output becomes the ACTIVE state, and the excitation is started at the initial electrical angle.

• Initializing operation during motor operating

Please input the reset signal to PS terminal when the translator circuit is initialized during motor operating. (Refer to P.19)

But at the time of PS=L⇒H, it returns from the standby state to the normal state and there is a delay of 40μs (max.) until the motor output has become the ACTIVE state, so please be careful.

○Control input timing

Please input as shown below because the translator circuit operates at the rising edge of CLK signal. If you disobey this timing and input, then there is the possibility that the translator circuit does not operate as expected. In addition, at the time of PS=L⇒H, it returns from the standby state to the normal state and there is a delay of 40μs (max.) until the motor output has become the ACTIVE state, so within this delay interval there is no phase advance operation even if CLK is inputted.

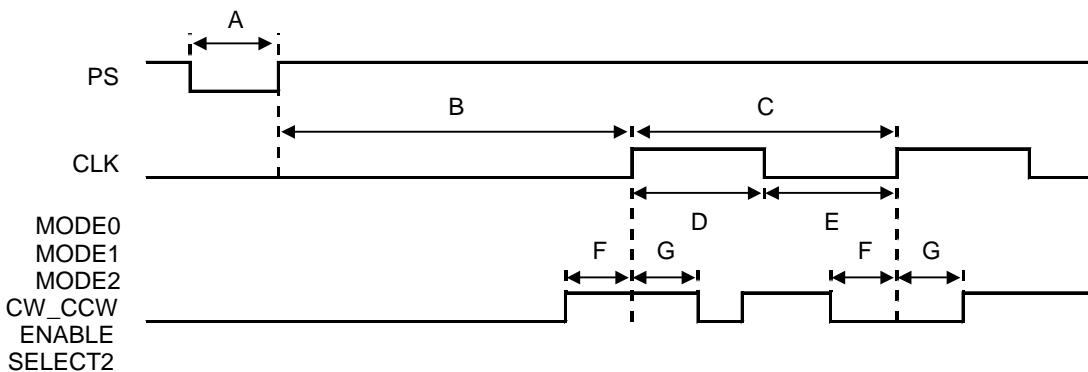

- A: PS minimum input pulse width.....20μs
- B: PS rising edge~CLK rising edge input possible maximum delay time.....40μs
- C: CLK minimum period.....4μs
- D: CLK minimum input H pulse width.....2μs
- E: CLK minimum input L pulse width.....2μs
- F: MODE0,MODE1,MODE2,CW_CCW,ENABLE,SELECT2 set-up time.....1μs
- G: MODE0,MODE1,MODE2,CW_CCW,ENABLE,SELECT2 hold time.....1μs

●CLK-IN drive mode (SELECT1=L)

• FULL STEP A (MODE0=L, MODE1=L, MODE2=L, SELECT2=L, CW_CCW=L, ENABLE=H)

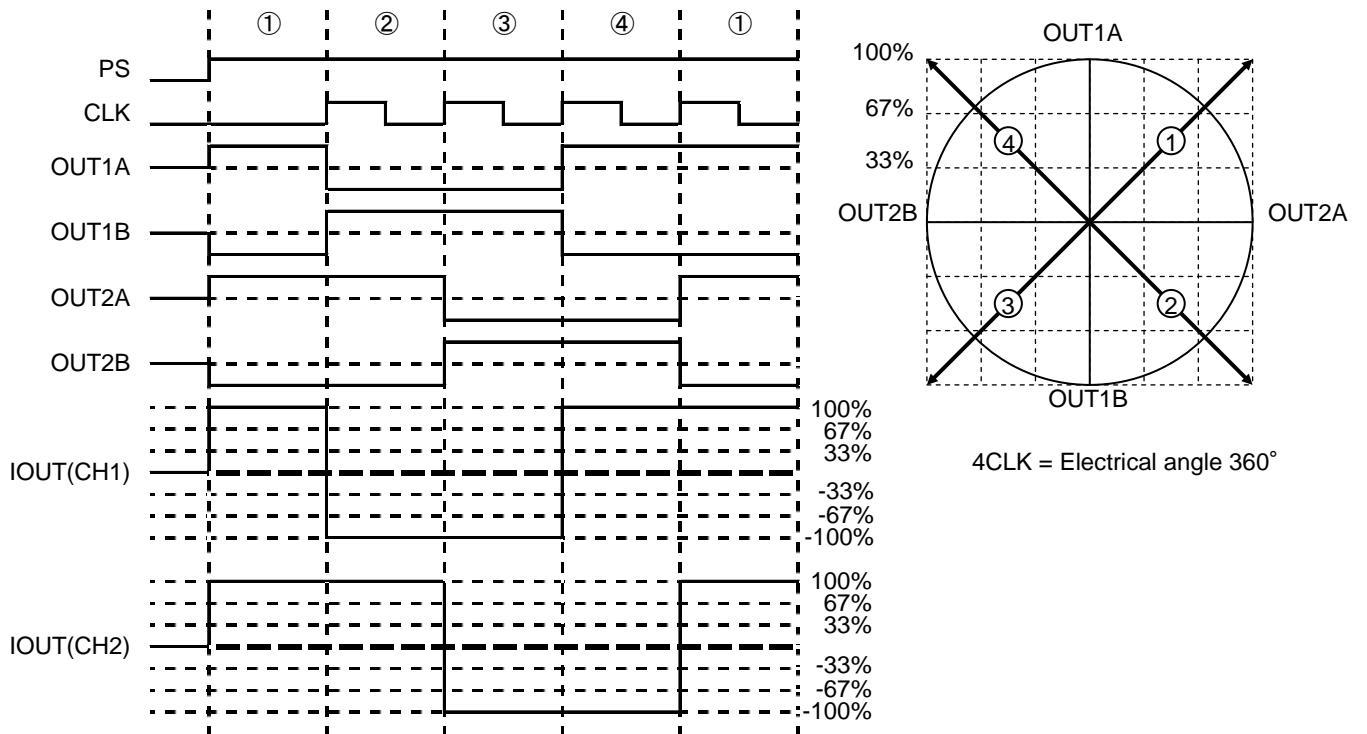

• HALF STEP A (MODE0=H, MODE1=L, MODE2=L, SELECT2=L, CW_CCW=L, ENABLE=H)

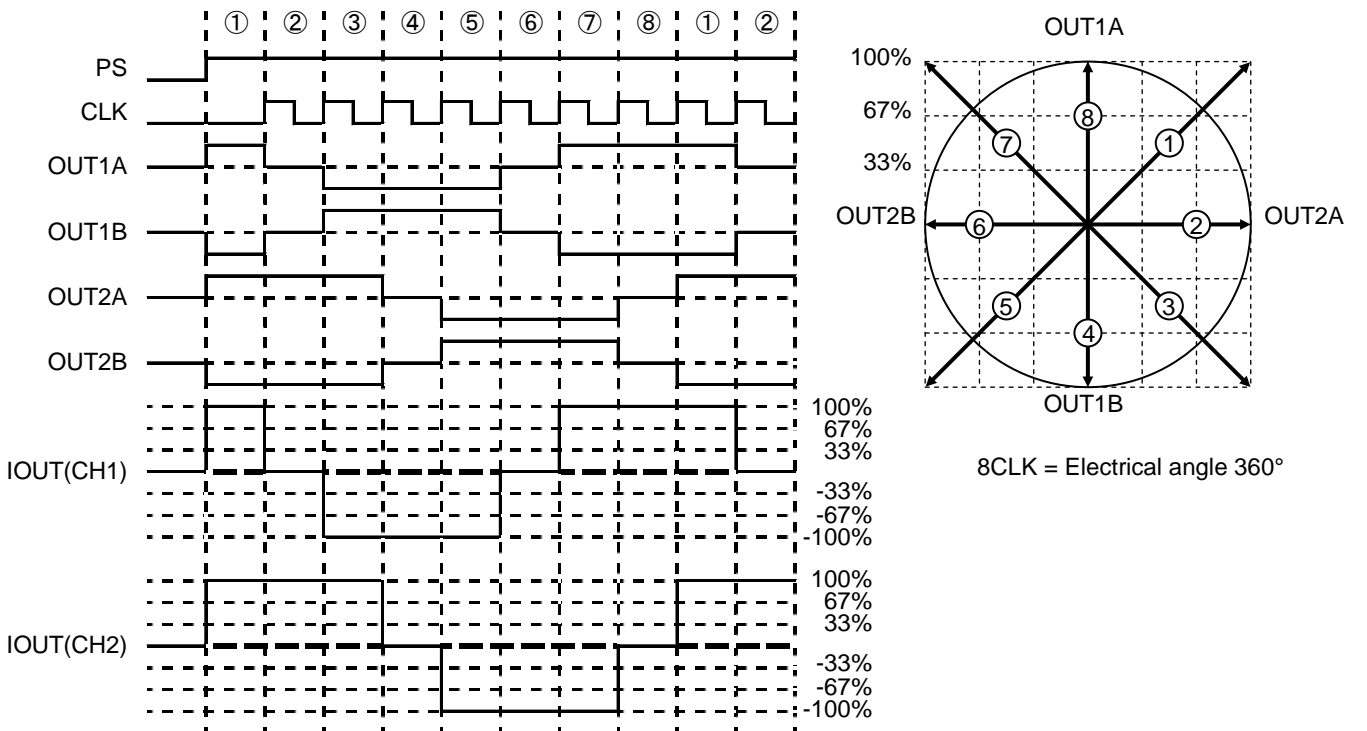

• HALF STEP B(MODE0=L, MODE1=H, MODE2=L, SELECT2=L, CW_CCW=L, ENABLE=H)

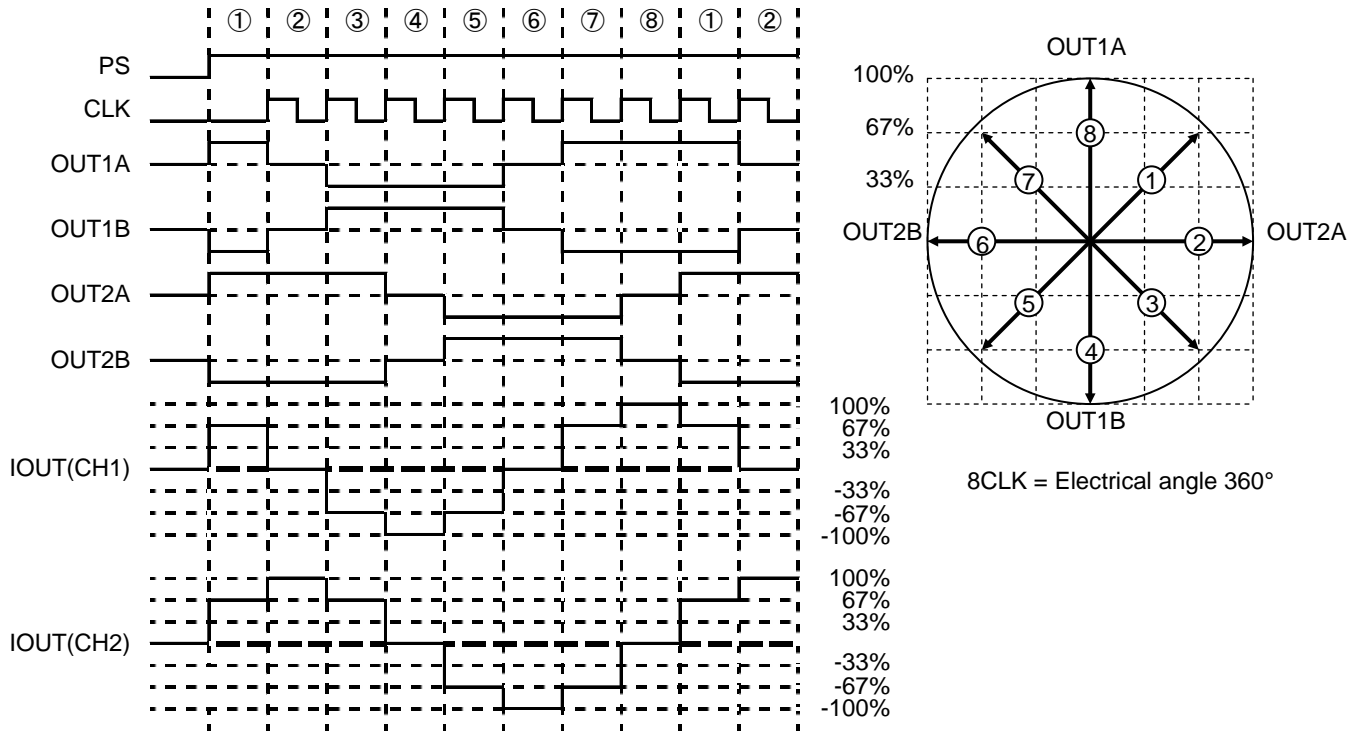

• QUARTER STEP A (MODE0=H, MODE1=H, MODE2=L, SELECT2=L CW_CCW=L, ENABLE=H)

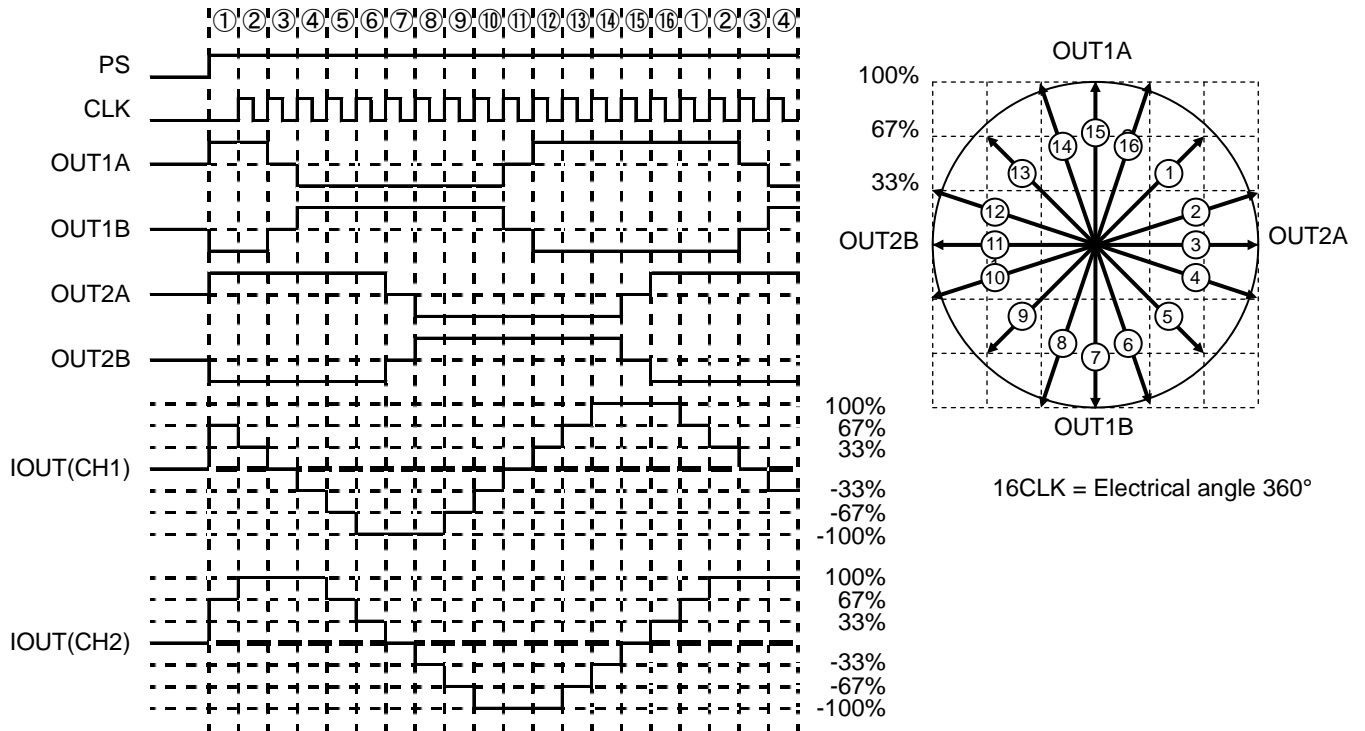

• Step sequence table(MODE2=H, CW_CCW=L、 initial electrical angle =step angle45°)

	Full step B	Half step C	Quarter step B	1/8 step	1/16 step	ch1 current[%]	ch2 current[%]	step angle[°]
		1	1	1	1	100.00	0.00	0.0
					2	99.52	9.80	5.6
				2	3	98.08	19.51	11.3
					4	95.69	29.03	16.9
			2	3	5	92.39	38.27	22.5
					6	88.19	47.14	28.1
				4	7	83.15	55.56	33.8
					8	77.30	63.44	39.4
Initial position→	1	2	3	5	9	70.71	70.71	45.0
					10	63.44	77.30	50.6
				6	11	55.56	83.15	56.3
					12	47.14	88.19	61.9
			4	7	13	38.27	92.39	67.5
					14	29.03	95.69	73.1
				8	15	19.51	98.08	78.8
					16	9.80	99.52	84.4
		3	5	9	17	0.00	100.00	90.0
					18	-9.80	99.52	95.6
				10	19	-19.51	98.08	101.3
					20	-29.03	95.69	106.9
			6	11	21	-38.27	92.39	112.5
					22	-47.14	88.19	118.1
				12	23	-55.56	83.15	123.8
					24	-63.44	77.30	129.4
	2	4	7	13	25	-70.71	70.71	135.0
					26	-77.30	63.44	140.6
				14	27	-83.15	55.56	146.3
					28	-88.19	47.14	151.9
			8	15	29	-92.39	38.27	157.5
					30	-95.69	29.03	163.1
				16	31	-98.08	19.51	168.8
					32	-99.52	9.80	174.4
		5	9	17	33	-100.00	0.00	180.0
					34	-99.52	-9.80	185.6
				18	35	-98.08	-19.51	191.3
					36	-95.69	-29.03	196.9
			10	19	37	-92.39	-38.27	202.5
					38	-88.19	-47.14	208.1
				20	39	-83.15	-55.56	213.8
					40	-77.30	-63.44	219.4
	3	6	11	21	41	-70.71	-70.71	225.0
					42	-63.44	-77.30	230.6
				22	43	-55.56	-83.15	236.3
					44	-47.14	-88.19	241.9
			12	23	45	-38.27	-92.39	247.5
					46	-29.03	-95.69	253.1
				24	47	-19.51	-98.08	258.8
					48	-9.80	-99.52	264.4
		7	13	25	49	0.00	-100.00	270.0
					50	9.80	-99.52	275.6
				26	51	19.51	-98.08	281.3
					52	29.03	-95.69	286.9
			14	27	53	38.27	-92.39	292.5
					54	47.14	-88.19	298.1
				28	55	55.56	-83.15	303.8
					56	63.44	-77.30	309.4
	4	8	15	29	57	70.71	-70.71	315.0
					58	77.30	-63.44	320.6
				30	59	83.15	-55.56	326.3
					60	88.19	-47.14	331.9
			16	31	61	92.39	-38.27	337.5
					62	95.69	-29.03	343.1
				32	63	98.08	-19.51	348.8
					64	99.52	-9.80	354.4

●PARALLEL-IN drive mode (SELECT1=H)

It is possible to drive stepping motor with FULL STEP, HALF STEP, and QUARTER STEP by inputting the following motor control signals using PARALLEL-IN drive mode.

Examples of control sequence and torque vector

FULL STEP A

Controlled by 2 logic signals of PHASE1 & PHASE2

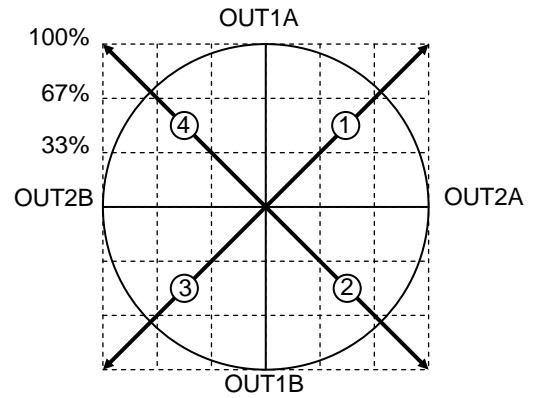
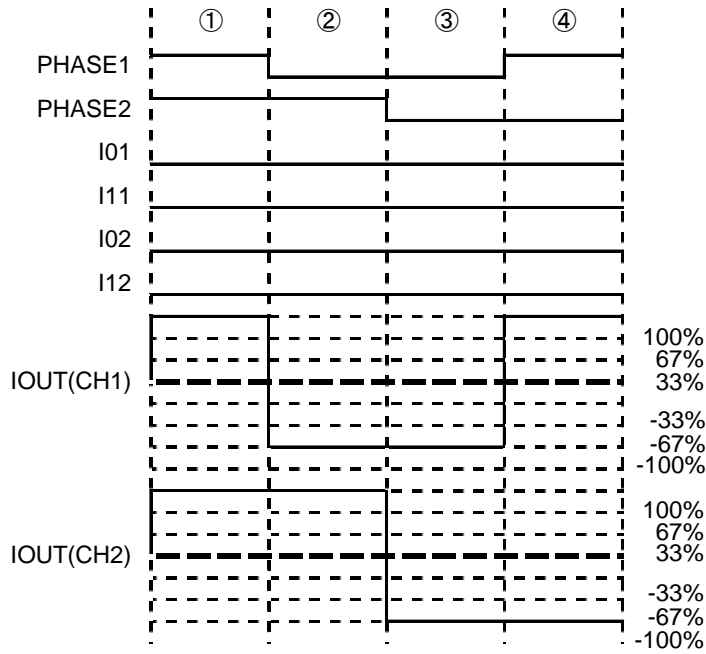

HALF STEP A

Controlled by 4 logic signals of PHASE1, PHASE2, I01(I11), and I02(I12)

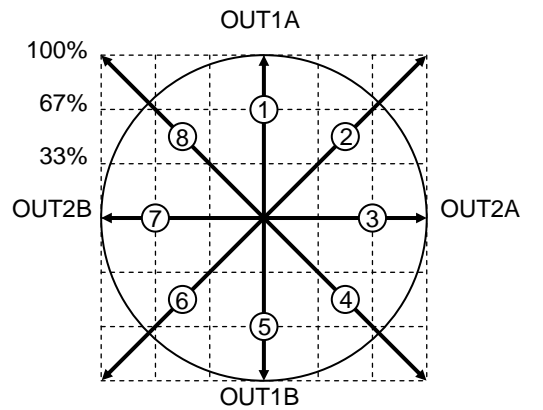
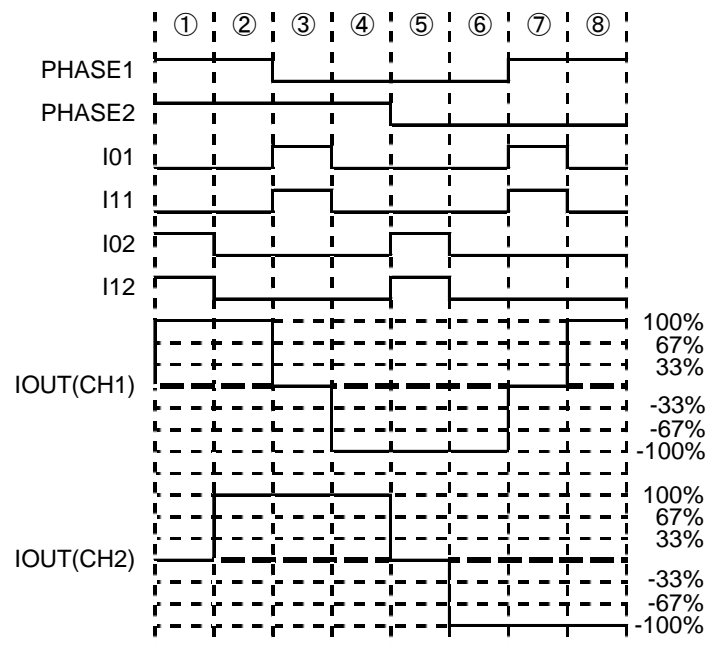

HALF STEP B

Controlled by 6 logic signals of PHASE1, PHASE2, I01, I11, I02, and I12

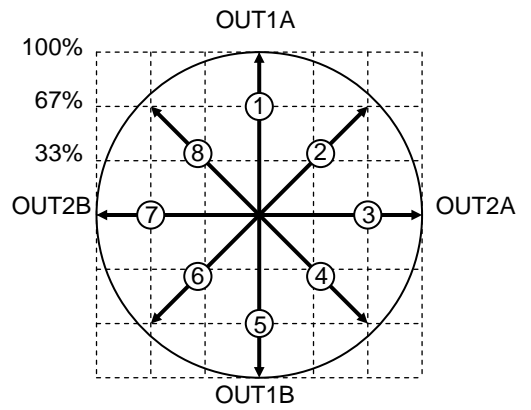
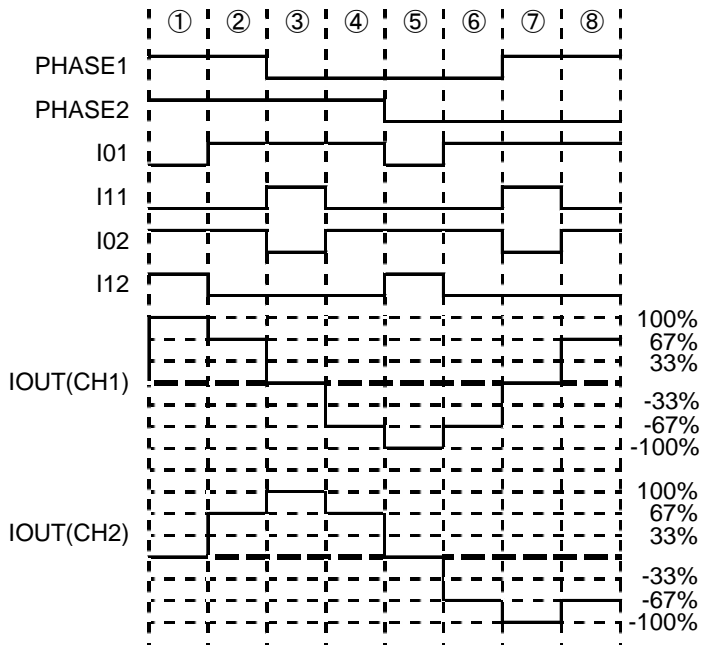

QUARTER STEP A

Controlled by 6 logic signals of PHASE1, PHASE2, I01, I11, I02, and I12

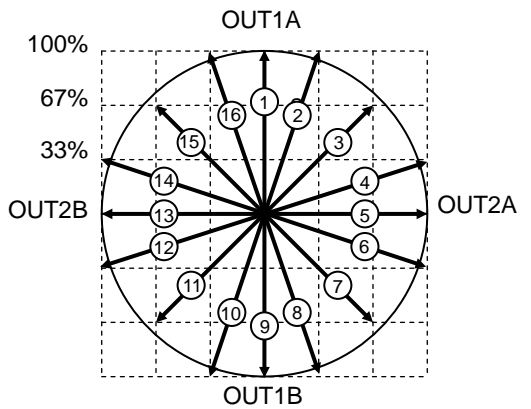
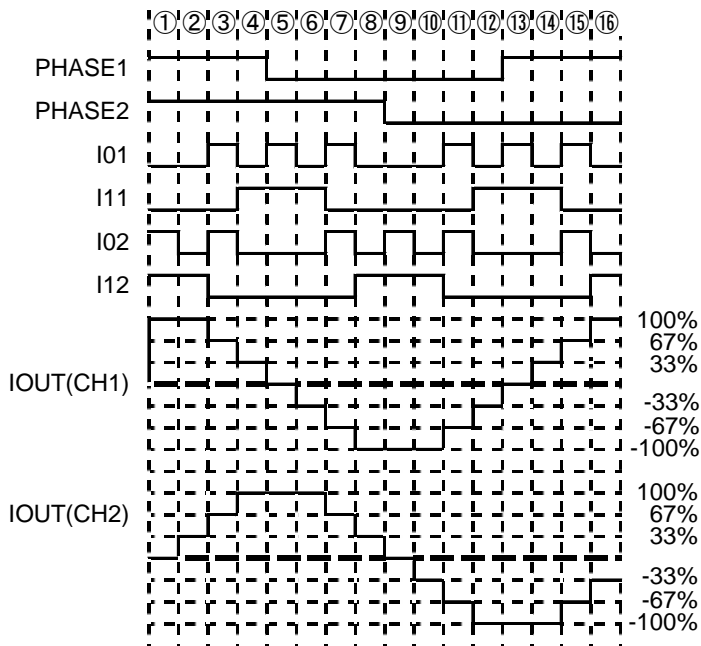

- Reset timing chart (QUARTER STEP A, MODE0=H, MODE1=H, MODE2=L, CW_CCW=L, ENABLE=H, SELECT1=L)
 If the terminal PS is input to L, the reset operation is done with regardless of other input signals when reset the translator circuit while motor is working. At this time, IC internal circuit enters the standby mode, and makes the motor output OPEN.

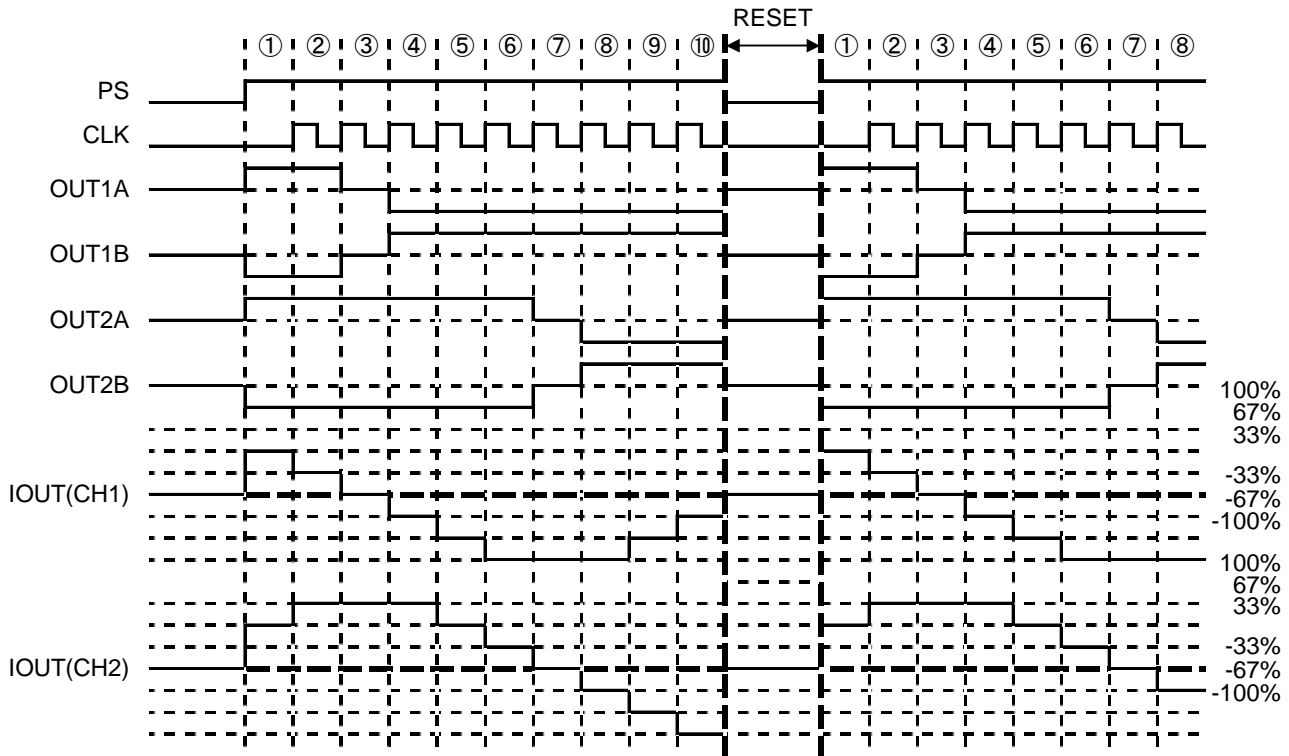

- CW_CCW Switch timing chart (FULL STEP A, MODE0=L, MODE1=L, MODE2=L, ENABLE=H, SELECT1=L)
 The switch of CW_CCW is reflected by the rising edge of CLK that comes immediately after the changes of the CW_CCW signal. However, depending on the state of operation of the motor at the switch the motor cannot follow even if the control on driver IC side is correspondent and there are possibilities of step-out and mistake step in motor, so please evaluate the sequence of the switch enough.

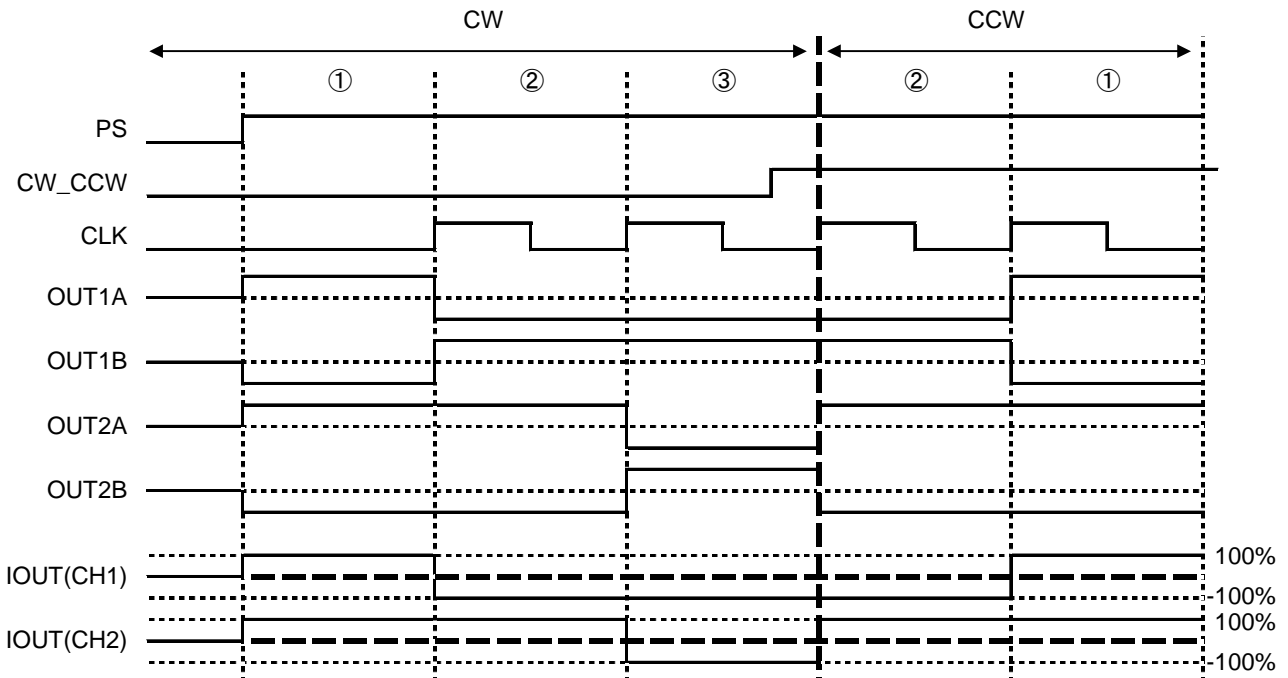

- ENABLE Switch timing chart (FULL STEP A, MODE0=L, MODE1=L, MODE2=L, ENABLE=H, SELECT1=L)
 The switch of the ENABLE signal is reflected by the change in the ENABLE signal with regardless of other input signals. In the section of ENABLE=L, the motor output becomes OPEN and the electrical angle doesn't advance. Because the translator circuit stop and CLK input is canceled. Therefore, the progress of ENABLE=L→H is completed before the input of ENABLE=L. Excitation mode (MODE0, MODE1, MODE2) also switches within ENABLE=L interval. Where excitation mode switched within ENABLE=L interval, restoring of ENABLE=L→H was done in the excitation mode after switch.

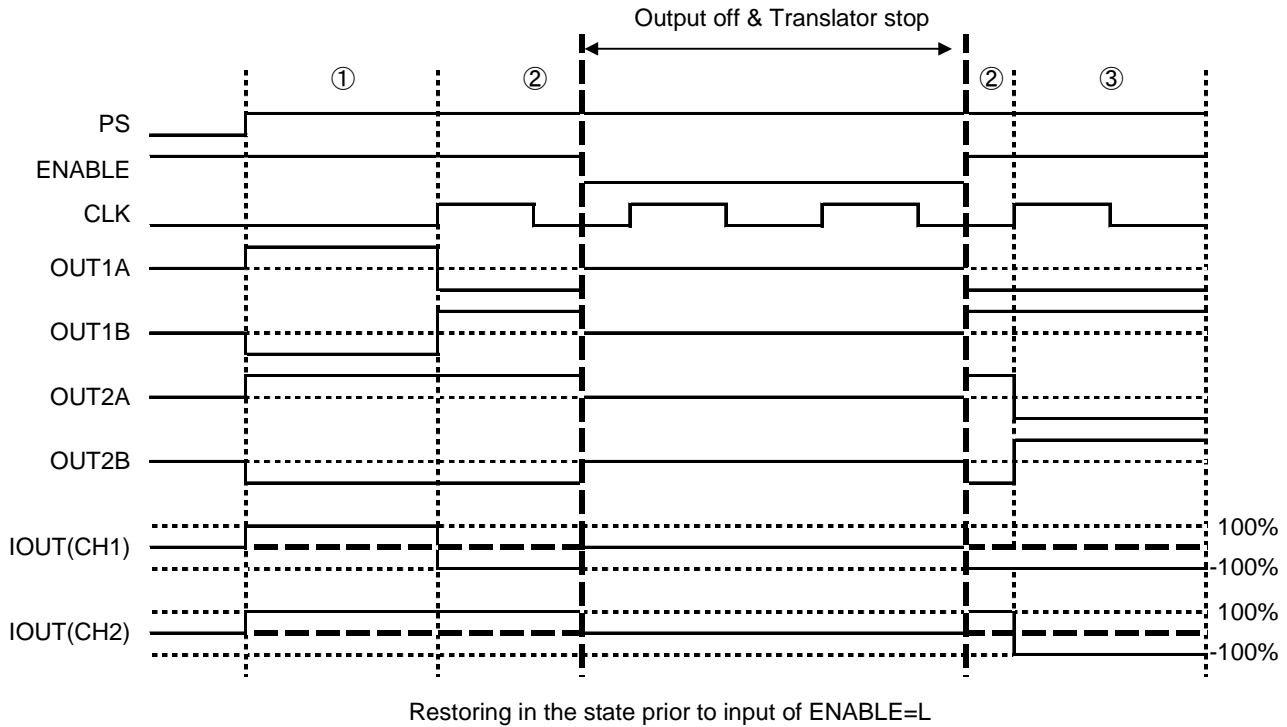

- About the switch of the motor excitation mode
 The switch of the excitation mode can be done with regardless of the CLK signal at the same time as changing of the signal MODE0, MODE1, MODE2 and SELECT2. The following built-in function can prevent motor out-of-step caused by discrepancies of torque vector of transitional excitations during switch between excitation modes. However, due to operation state of motor during switch, motor may not act following control on IC side of controller, and thereby lead to out-of-step or miss step. Therefore, switch sequence shall be evaluated sufficiently before any decision.

- Cautions of bidirectional switch of CW_CCW and excitation modes (MODE0, MODE1, MODE2, SELECT2)
 As shown in the figure below, the area between the end of reset discharge (PS=L→H) and beginning of the first CLK signal input is defined as interval A, while the area post the end of the first CLK signal input is defined as interval B.

Interval A

=> For CW_CCW, no limitation is applied on switch of excitation mode.

Interval B

=> In CLK1 period, or within ENABLE=L interval, CW_CCW and excitation mode can't be switched together.

Violation of this restriction may lead to false step (with one extra leading phase) or out-of-step.

Therefore, in case that CW_CCW and excitation modes are switched simultaneously, PS terminal must be input with reset signal. Then start to operate in interval A before carrying out such bidirectional switch.

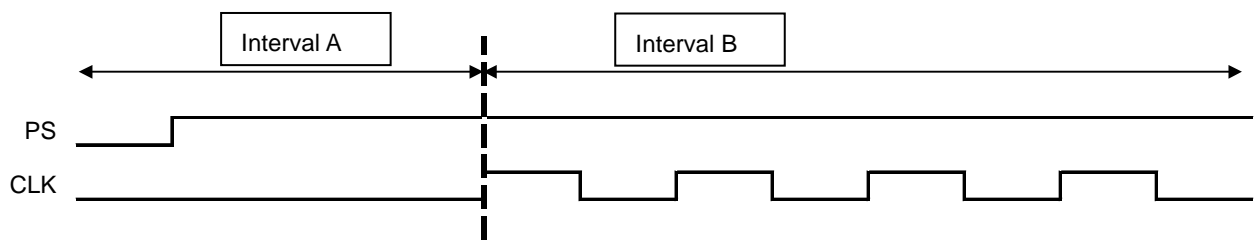

Application Example

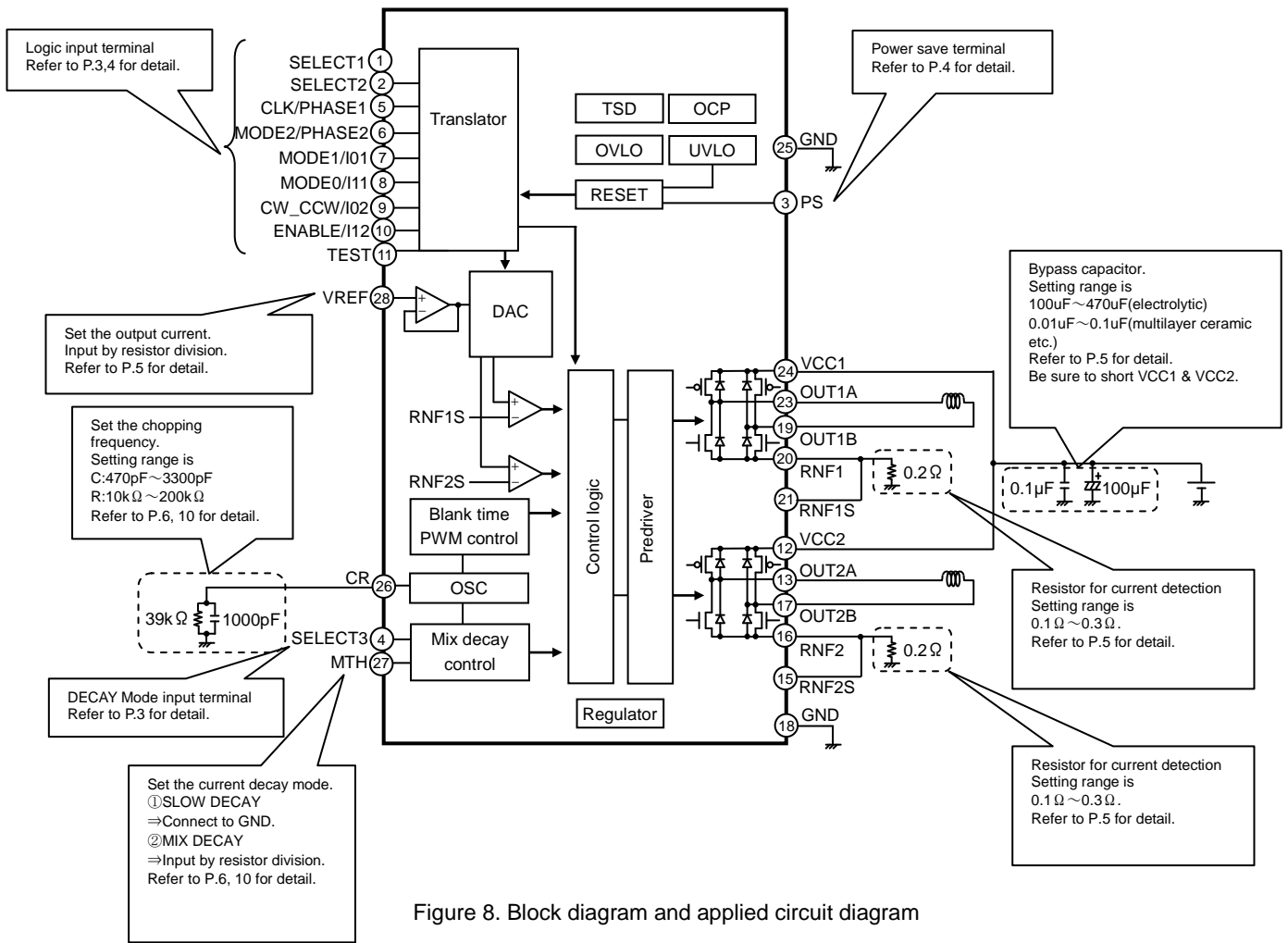

Power dissipation

Please confirm that the IC's chip temperature T_j is not over 150°C , while considering the IC's power consumption (W), Thermal Resistance($^{\circ}\text{C}/\text{W}$) and ambient temperature (T_a). When $T_j=150^{\circ}\text{C}$ is exceeded the functions as a semiconductor do not operate and problems such as parasitism and leaks occur. Constant use under these circumstances leads to deterioration and eventually destruction of the IC. $T_{j\text{max}}=150^{\circ}\text{C}$ must be strictly obeyed under all circumstances.

Thermal Calculation

The IC's consumed power can be estimated roughly with the power supply voltage (V_{cc}), circuit current (I_{cc}), output ON resistance (R_{ONH} , R_{ONL}) and motor output current value (I_{OUT}).

The calculation method during FULL STEP drive, SLOW DECAY mode is shown here:

Consumed power of the V_{cc} [W] = V_{cc} [V] · I_{cc} [A] ·····①

Consumed power of the output DMOS [W] = $\frac{(R_{ONH}[\Omega] + R_{ONL}[\Omega]) \cdot I_{OUT}[A]^2 \cdot 2[\text{ch}] \cdot \text{on_duty}}{\text{During output ON}}$
 $+\frac{(2 \cdot R_{ONL}[\Omega]) \cdot I_{OUT}[A]^2 \cdot 2[\text{ch}] \cdot (1 - \text{on_duty})}{\text{During current decay}} \cdot \dots \dots \dots \text{②}$

However, on duty: PWM on duty = $t_{on} / (t_{chop})$

t_{on} varies depending on the L and R values of the motor coil and the current set value. Please confirm by actual measurement, or make an approximate calculation.

t_{chop} is the chopping period, which depends on the external CR. See P.8 for details.

IC number	Upper PchDMOS ON Resistance $R_{ONH}[\Omega]$ (Typ)	Lower NchDMOS ON Resistance $R_{ONL}[\Omega]$ (Typ)
BD63920MUV	0.32	0.17

Consumed power of total IC W_{total} [W] = ① + ②

Junction temperature $T_j = T_a[^{\circ}\text{C}] + \theta_{ja}[^{\circ}\text{C}/\text{W}] \cdot W_{total}$ [W]

However, the thermal resistance value θ_{ja} [$^{\circ}\text{C}/\text{W}$] differs greatly depending on circuit board conditions. Refer to the derating curve on P.25. Also, we are taking measurements of thermal resistance value θ_{ja} of boards actually in use. Please feel free to contact our salesman. The calculated values above are only theoretical. For actual thermal design, please perform sufficient thermal evaluation for the application board used, and create the thermal design with enough margin to not exceed $T_{j\text{max}}=150^{\circ}\text{C}$. Although unnecessary with normal use, if the IC is to be used under especially strict heat conditions, please consider externally attaching a Schottky diode between the motor output terminal and GND to abate heat from the IC.

○Temperature Monitoring

In respect of BD63920MUV, there is a way to directly measure the approximate chip temperature by using the TEST terminal with a protection diode for prevention from electrostatic discharge. However, temperature monitor using this TEST terminal is only for evaluation and experimenting, and must not be used in actual usage conditions.

- (1) Measure the terminal voltage when a current of $I_{diode}=50\mu\text{A}$ flows from the TEST or MODEx terminal to the GND, without supplying VCC to the IC. This measurement is of the V_f voltage inside the diode.
- (2) Measure the temperature characteristics of this terminal voltage. (V_f has a linear negative temperature factor against the temperature.) With the results of these temperature characteristics, chip temperature may be calibrated from the TEST terminal voltage.
- (3) Supply VCC, confirm the TEST terminal voltage while running the motor, and the chip temperature can be approximated from the results of (2).

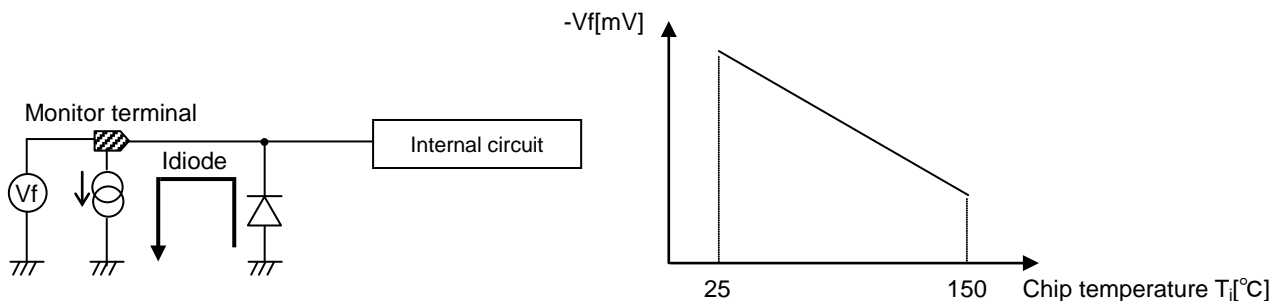

Figure 9. Model diagram for measuring chip temperature

I/O equivalent circuit

CLK/PHASE1
 MODE2/PHASE2
 MODE1/I01
 MODE0/I11
 CW_CCW/I02
 ENABLE/I12
 SELECT1
 SELECT2
 SELECT3
 PS

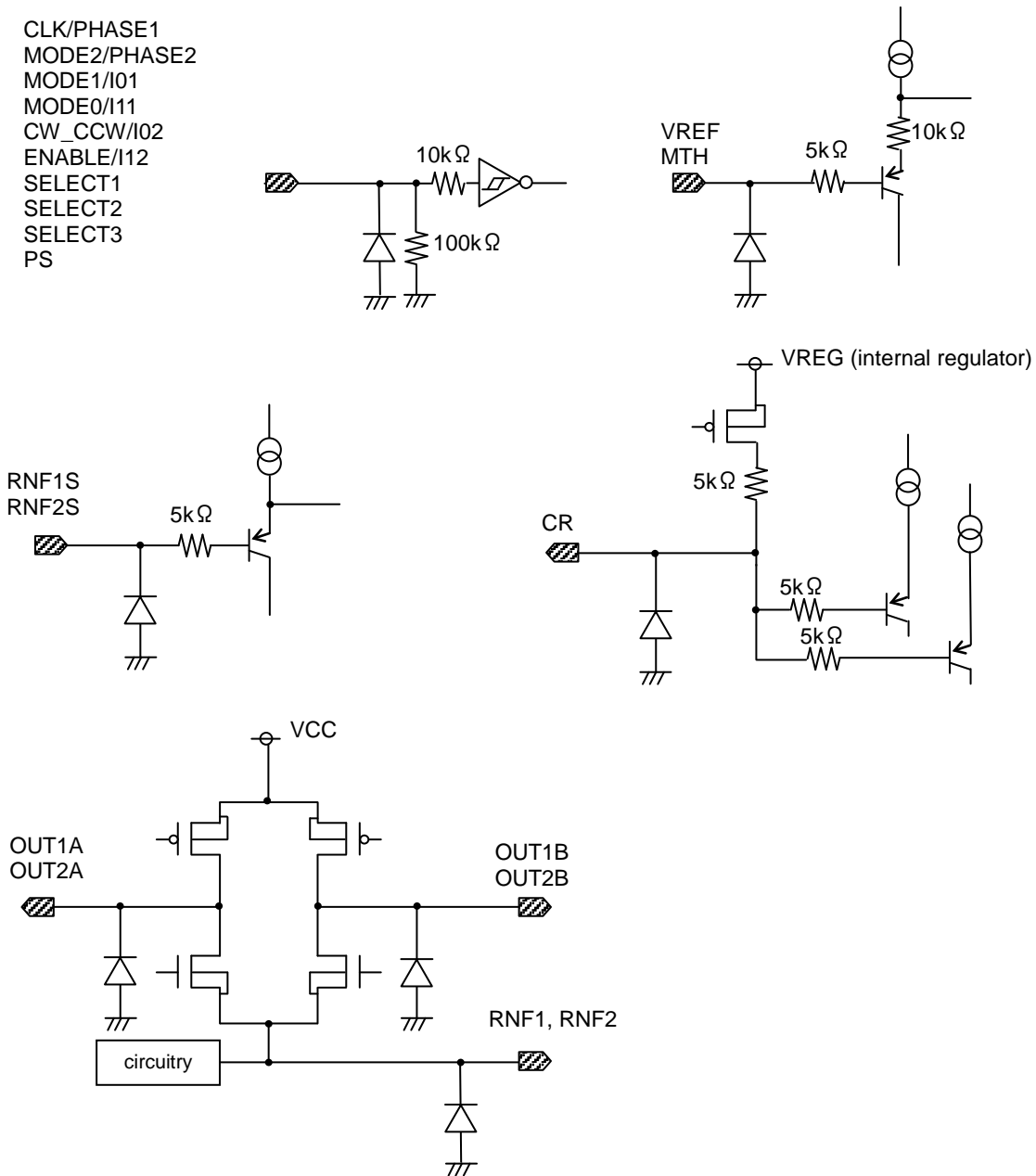

Figure 10. I/O equivalent circuit

Operational Notes

1. Reverse Connection of Power Supply

Connecting the power supply in reverse polarity can damage the IC. Take precautions against reverse polarity when connecting the power supply, such as mounting an external diode between the power supply and the IC's power supply pins.

2. Power Supply Lines

Design the PCB layout pattern to provide low impedance supply lines. Separate the ground and supply lines of the digital and analog blocks to prevent noise in the ground and supply lines of the digital block from affecting the analog block. Furthermore, connect a capacitor to ground at all power supply pins. Consider the effect of temperature and aging on the capacitance value when using electrolytic capacitors.

3. Ground Voltage

Ensure that no pins are at a voltage below that of the ground pin at any time, even during transient condition.

4. Ground Wiring Pattern

When using both small-signal and large-current ground traces, the two ground traces should be routed separately but connected to a single ground at the reference point of the application board to avoid fluctuations in the small-signal ground caused by large currents. Also ensure that the ground traces of external components do not cause variations on the ground voltage. The ground lines must be as short and thick as possible to reduce line impedance.

5. Thermal Consideration

Should by any chance the power dissipation rating be exceeded the rise in temperature of the chip may result in deterioration of the properties of the chip. The absolute maximum rating of the Pd stated in this specification is when the IC is mounted on a 70mm x 70mm x 1.6mm glass epoxy board. In case of exceeding this absolute maximum rating, increase the board size and copper area to prevent exceeding the Pd rating.

6. Recommended Operating Conditions

These conditions represent a range within which the expected characteristics of the IC can be approximately obtained. The electrical characteristics are guaranteed under the conditions of each parameter.

7. Inrush Current

When power is first supplied to the IC, it is possible that the internal logic may be unstable and inrush current may flow instantaneously due to the internal powering sequence and delays, especially if the IC has more than one power supply. Therefore, give special consideration to power coupling capacitance, power wiring, width of ground wiring, and routing of connections.

8. Operation Under Strong Electromagnetic Field

Operating the IC in the presence of a strong electromagnetic field may cause the IC to malfunction.

9. Testing on Application Boards

When testing the IC on an application board, connecting a capacitor directly to a low-impedance output pin may subject the IC to stress. Always discharge capacitors completely after each process or step. The IC's power supply should always be turned off completely before connecting or removing it from the test setup during the inspection process. To prevent damage from static discharge, ground the IC during assembly and use similar precautions during transport and storage.

10. Inter-pin Short and Mounting Errors

Ensure that the direction and position are correct when mounting the IC on the PCB. Incorrect mounting may result in damaging the IC. Avoid nearby pins being shorted to each other especially to ground, power supply and output pin. Inter-pin shorts could be due to many reasons such as metal particles, water droplets (in very humid environment) and unintentional solder bridge deposited in between pins during assembly to name a few.

11. Unused Input Pins

Input pins of an IC are often connected to the gate of a MOS transistor. The gate has extremely high impedance and extremely low capacitance. If left unconnected, the electric field from the outside can easily charge it. The small charge acquired in this way is enough to produce a significant effect on the conduction through the transistor and cause unexpected operation of the IC. So unless otherwise specified, unused input pins should be connected to the power supply or ground line.

Operational Notes – continued

12. Regarding the Input Pin of the IC

This monolithic IC contains P+ isolation and P substrate layers between adjacent elements in order to keep them isolated. P-N junctions are formed at the intersection of the P layers with the N layers of other elements, creating a parasitic diode or transistor. For example (refer to figure below):

When GND > Pin A and GND > Pin B, the P-N junction operates as a parasitic diode.
 When GND > Pin B, the P-N junction operates as a parasitic transistor.

Parasitic diodes inevitably occur in the structure of the IC. The operation of parasitic diodes can result in mutual interference among circuits, operational faults, or physical damage. Therefore, conditions that cause these diodes to operate, such as applying a voltage lower than the GND voltage to an input pin (and thus to the P substrate) should be avoided.

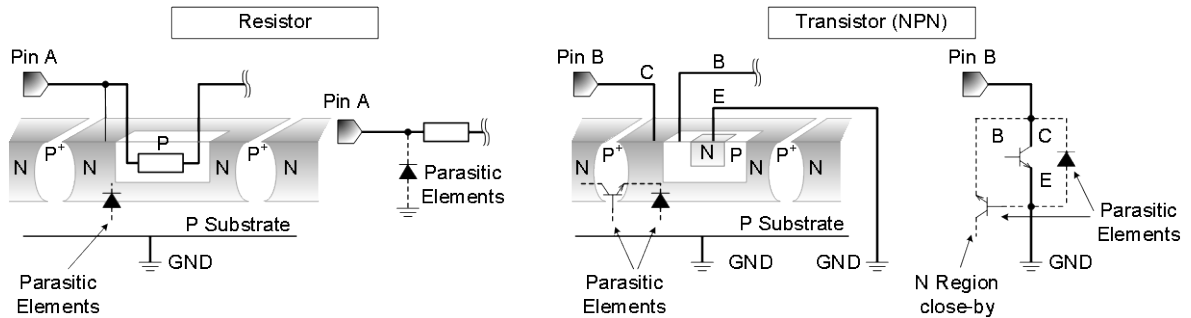

Figure 11. Example of monolithic IC structure

13. Thermal Shutdown Circuit(TSD)

This IC has a built-in thermal shutdown circuit that prevents heat damage to the IC. Normal operation should always be within the IC's power dissipation rating. If however the rating is exceeded for a continued period, the junction temperature (Tj) will rise which will activate the TSD circuit that will turn OFF all output pins. When the Tj falls below the TSD threshold, the circuits are automatically restored to normal operation.

Note that the TSD circuit operates in a situation that exceeds the absolute maximum ratings and therefore, under no circumstances, should the TSD circuit be used in a set design or for any purpose other than protecting the IC from heat damage.

14. Over Current Protection Circuit (OCP)

This IC incorporates an integrated overcurrent protection circuit that is activated when the load is shorted. This protection circuit is effective in preventing damage due to sudden and unexpected incidents. However, the IC should not be used in applications characterized by continuous operation or transitioning of the protection circuit.

15. Operation Under Strong Electromagnetic Field(BD63920MUV)

The IC is not designed for using in the presence of strong electromagnetic field. Be sure to confirm that no malfunction is found when using the IC in a strong electromagnetic field.

16. Metal on the backside (Define the side where product markings are printed as front) (BD63920MUV)

The metal on the backside is shorted with the backside of IC chip therefore it should be connected to GND. Be aware that here is a possibility of malfunction or destruction if it is shorted with any potential other than GND.

17. TEST Terminal(BD63920MUV)

Be sure to connect TEST pin to GND.

Ordering Information

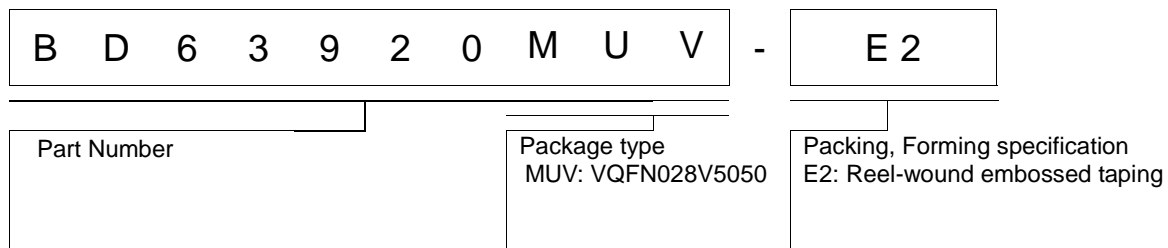

Marking Diagrams

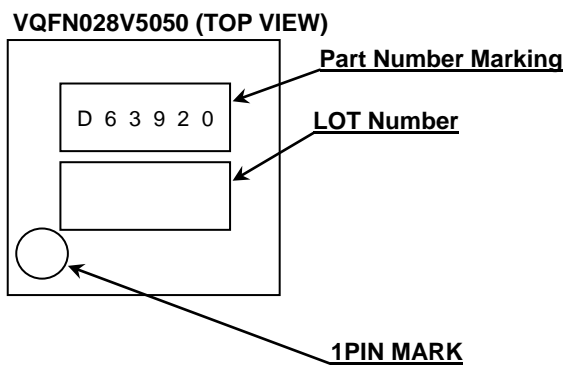

Physical Dimension, Tape and Reel Information

Package Name	VQFN028V5050
--------------	--------------

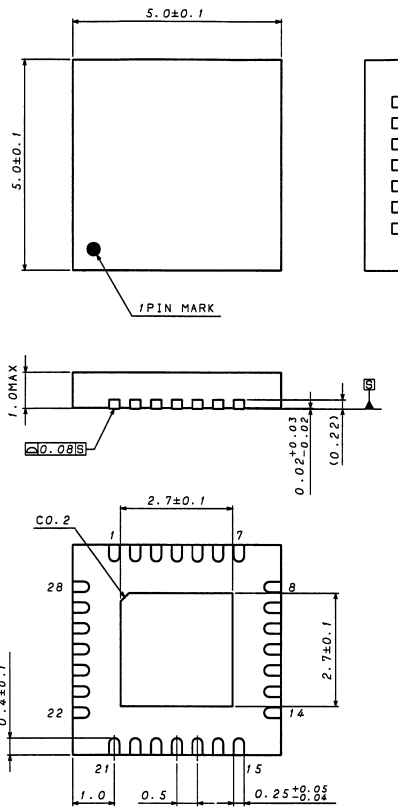

(UNIT: mm)

PKG: VQFN028V5050
Drawing No. EX473-5002-2

<Tape and Reel information>

Tape	Embossed carrier tape
Quantity	2500pcs
Direction of feed	E2 (The direction is the 1pin of product is at the upper left when you hold reel on the left hand and you pull out the tape on the right hand)

*Order quantity needs to be multiple of the minimum quantity.

Revision History

Date	Revision	Changes
12.Dec.2016	001	New Release

Notice

Precaution on using ROHM Products

- Our Products are designed and manufactured for application in ordinary electronic equipments (such as AV equipment, OA equipment, telecommunication equipment, home electronic appliances, amusement equipment, etc.). If you intend to use our Products in devices requiring extremely high reliability (such as medical equipment ^(Note 1), transport equipment, traffic equipment, aircraft/spacecraft, nuclear power controllers, fuel controllers, car equipment including car accessories, safety devices, etc.) and whose malfunction or failure may cause loss of human life, bodily injury or serious damage to property ("Specific Applications"), please consult with the ROHM sales representative in advance. Unless otherwise agreed in writing by ROHM in advance, ROHM shall not be in any way responsible or liable for any damages, expenses or losses incurred by you or third parties arising from the use of any ROHM's Products for Specific Applications.

(Note1) Medical Equipment Classification of the Specific Applications

JAPAN	USA	EU	CHINA
CLASS III	CLASS III	CLASS II b	CLASS III
CLASS IV		CLASS III	

- ROHM designs and manufactures its Products subject to strict quality control system. However, semiconductor products can fail or malfunction at a certain rate. Please be sure to implement, at your own responsibilities, adequate safety measures including but not limited to fail-safe design against the physical injury, damage to any property, which a failure or malfunction of our Products may cause. The following are examples of safety measures:
 - Installation of protection circuits or other protective devices to improve system safety
 - Installation of redundant circuits to reduce the impact of single or multiple circuit failure
- Our Products are designed and manufactured for use under standard conditions and not under any special or extraordinary environments or conditions, as exemplified below. Accordingly, ROHM shall not be in any way responsible or liable for any damages, expenses or losses arising from the use of any ROHM's Products under any special or extraordinary environments or conditions. If you intend to use our Products under any special or extraordinary environments or conditions (as exemplified below), your independent verification and confirmation of product performance, reliability, etc. prior to use, must be necessary:
 - Use of our Products in any types of liquid, including water, oils, chemicals, and organic solvents
 - Use of our Products outdoors or in places where the Products are exposed to direct sunlight or dust
 - Use of our Products in places where the Products are exposed to sea wind or corrosive gases, including Cl₂, H₂S, NH₃, SO₂, and NO₂
 - Use of our Products in places where the Products are exposed to static electricity or electromagnetic waves
 - Use of our Products in proximity to heat-producing components, plastic cords, or other flammable items
 - Sealing or coating our Products with resin or other coating materials
 - Use of our Products without cleaning residue of flux (even if you use no-clean type fluxes, cleaning residue of flux is recommended); or Washing our Products by using water or water-soluble cleaning agents for cleaning residue after soldering
 - Use of the Products in places subject to dew condensation
- The Products are not subject to radiation-proof design.
- Please verify and confirm characteristics of the final or mounted products in using the Products.
- In particular, if a transient load (a large amount of load applied in a short period of time, such as pulse. is applied, confirmation of performance characteristics after on-board mounting is strongly recommended. Avoid applying power exceeding normal rated power; exceeding the power rating under steady-state loading condition may negatively affect product performance and reliability.
- De-rate Power Dissipation depending on ambient temperature. When used in sealed area, confirm that it is the use in the range that does not exceed the maximum junction temperature.
- Confirm that operation temperature is within the specified range described in the product specification.
- ROHM shall not be in any way responsible or liable for failure induced under deviant condition from what is defined in this document.

Precaution for Mounting / Circuit board design

- When a highly active halogenous (chlorine, bromine, etc.) flux is used, the residue of flux may negatively affect product performance and reliability.
- In principle, the reflow soldering method must be used on a surface-mount products, the flow soldering method must be used on a through hole mount products. If the flow soldering method is preferred on a surface-mount products, please consult with the ROHM representative in advance.

For details, please refer to ROHM Mounting specification

Precautions Regarding Application Examples and External Circuits

1. If change is made to the constant of an external circuit, please allow a sufficient margin considering variations of the characteristics of the Products and external components, including transient characteristics, as well as static characteristics.
2. You agree that application notes, reference designs, and associated data and information contained in this document are presented only as guidance for Products use. Therefore, in case you use such information, you are solely responsible for it and you must exercise your own independent verification and judgment in the use of such information contained in this document. ROHM shall not be in any way responsible or liable for any damages, expenses or losses incurred by you or third parties arising from the use of such information.

Precaution for Electrostatic

This Product is electrostatic sensitive product, which may be damaged due to electrostatic discharge. Please take proper caution in your manufacturing process and storage so that voltage exceeding the Products maximum rating will not be applied to Products. Please take special care under dry condition (e.g. Grounding of human body / equipment / solder iron, isolation from charged objects, setting of Ionizer, friction prevention and temperature / humidity control).

Precaution for Storage / Transportation

1. Product performance and soldered connections may deteriorate if the Products are stored in the places where:
 - [a] the Products are exposed to sea winds or corrosive gases, including Cl₂, H₂S, NH₃, SO₂, and NO₂
 - [b] the temperature or humidity exceeds those recommended by ROHM
 - [c] the Products are exposed to direct sunshine or condensation
 - [d] the Products are exposed to high Electrostatic
2. Even under ROHM recommended storage condition, solderability of products out of recommended storage time period may be degraded. It is strongly recommended to confirm solderability before using Products of which storage time is exceeding the recommended storage time period.
3. Store / transport cartons in the correct direction, which is indicated on a carton with a symbol. Otherwise bent leads may occur due to excessive stress applied when dropping of a carton.
4. Use Products within the specified time after opening a humidity barrier bag. Baking is required before using Products of which storage time is exceeding the recommended storage time period.

Precaution for Product Label

A two-dimensional barcode printed on ROHM Products label is for ROHM's internal use only.

Precaution for Disposition

When disposing Products please dispose them properly using an authorized industry waste company.

Precaution for Foreign Exchange and Foreign Trade act

Since concerned goods might be fallen under listed items of export control prescribed by Foreign exchange and Foreign trade act, please consult with ROHM in case of export.

Precaution Regarding Intellectual Property Rights

1. All information and data including but not limited to application example contained in this document is for reference only. ROHM does not warrant that foregoing information or data will not infringe any intellectual property rights or any other rights of any third party regarding such information or data.
2. ROHM shall not have any obligations where the claims, actions or demands arising from the combination of the Products with other articles such as components, circuits, systems or external equipment (including software).
3. No license, expressly or implied, is granted hereby under any intellectual property rights or other rights of ROHM or any third parties with respect to the Products or the information contained in this document. Provided, however, that ROHM will not assert its intellectual property rights or other rights against you or your customers to the extent necessary to manufacture or sell products containing the Products, subject to the terms and conditions herein.

Other Precaution



1. This document may not be reprinted or reproduced, in whole or in part, without prior written consent of ROHM.
2. The Products may not be disassembled, converted, modified, reproduced or otherwise changed without prior written consent of ROHM.
3. In no event shall you use in any way whatsoever the Products and the related technical information contained in the Products or this document for any military purposes, including but not limited to, the development of mass-destruction weapons.
4. The proper names of companies or products described in this document are trademarks or registered trademarks of ROHM, its affiliated companies or third parties.

General Precaution





1. Before you use our Products, you are requested to carefully read this document and fully understand its contents. ROHM shall not be in any way responsible or liable for failure, malfunction or accident arising from the use of any ROHM's Products against warning, caution or note contained in this document.
2. All information contained in this document is current as of the issuing date and subject to change without any prior notice. Before purchasing or using ROHM's Products, please confirm the latest information with a ROHM sales representative.
3. The information contained in this document is provided on an "as is" basis and ROHM does not warrant that all information contained in this document is accurate and/or error-free. ROHM shall not be in any way responsible or liable for any damages, expenses or losses incurred by you or third parties resulting from inaccuracy or errors of or concerning such information.

Looking for pricing, stock, or lifecycle information?

Click below to explore more details on WIN SOURCE:

-  [View BD63920MUV-E2 on WIN SOURCE](#)
-  [Rohm Semiconductor](#) Information

Optimize Your Supply Chain with WIN SOURCE Solutions

-  Global Sourcing Solution
-  Obsolete Management
-  Cost Control Management
-  Shortage Management
-  Alternative Solution
-  Excess Inventory Management