



**THE DATASHEET OF  
BD63730EFV-E2**



# 36V High-performance and High-reliability Withstand Voltage Stepping Motor Driver

**BD63730EFV**

## General Description

BD63730EFV is a low-power motor driver that drives load by PWM current. Rated power supply voltage of the device is 36V, and rated output current is 3.0A. The input interface are interchangeable between CLK-IN drive mode and the PARALLEL-IN drive mode, and excitation mode is corresponding to FULL STEP, HALF STEP (2 types), and QUARTER STEP modes via a built-in DAC. In terms of current decay, the FAST DECAY/SLOW DECAY ratio may be set without any limitation, and all available modes may be controlled in the most appropriate way. In addition, the power supply may be driven by one single system, which simplifies the design.

## Features

- Rated output current of 3.0A DC
- Low ON-Resistance DMOS output
- CLK-IN drive mode
- PARALLEL-IN drive mode
- PWM constant current control (other oscillation)
- Built-in spike noise cancel function (external noise filter is unnecessary)
- Full-step, half-step (two types), and quarter-step functionality
- Dynamic excitation mode switch
- Current decay mode switch (linearly variable FAST/SLOW DECAY ratio)
- Normal rotation & reverse rotation switching function
- Power save function
- Built-in logic input pull-down resistor
- Power-ON reset function
- Thermal shutdown circuit (TSD)
- Over-current protection circuit (OCP)
- Under voltage lock out circuit (UVLO)
- Over voltage lock out circuit (OVLO)
- Ghost Supply Prevention (protects against malfunction when power supply is disconnected)
- Electrostatic discharge: 4kV (HBM specification)
- Adjacent pins short protection
- Micro miniature, ultra-thin and high heat-radiation (exposed metal type) package

## Application

- PPC, multi-function printer, laser beam printer, and ink-jet printer
- Monitoring camera and WEB camera
- Sewing machine
- Photo printer, FAX, scanner and mini printer
- Toy and robot

## Key Specification

- Range of Power Supply Voltage: 19 to 28 [V]
- Rated Output Current (Continuous): 3.0 [A]
- Rated Output Current (Peak Value): 3.5 [A]
- Range of Operating Temperature: -25 to +85 [°C]
- Output ON-Resistance (Total of Upper and Lower Resistors): 0.40 [Ω] (Typ)

## Package

W(Typ) x D(Typ)x H(Max)

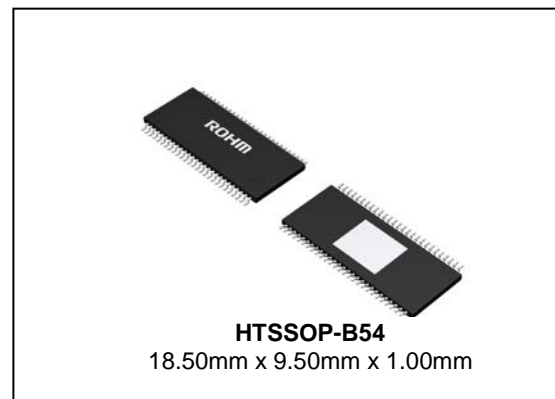

## Typical Application Circuit

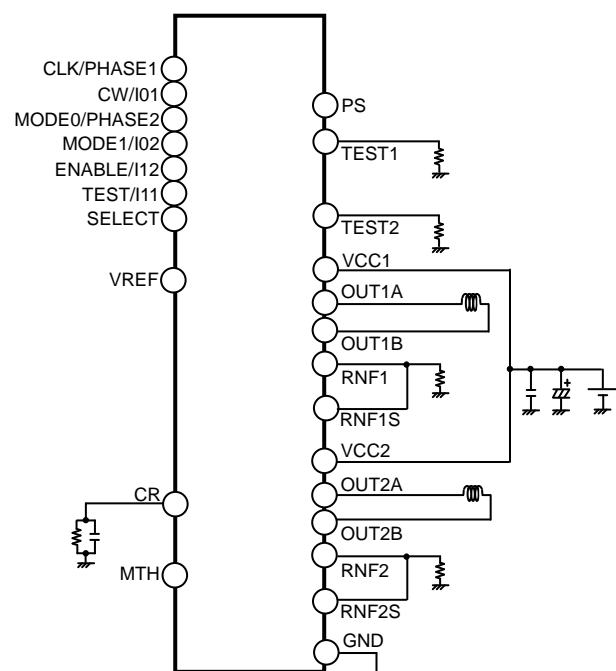

Figure 1. BD63730EFV Application Circuit Diagram

Pin Configuration

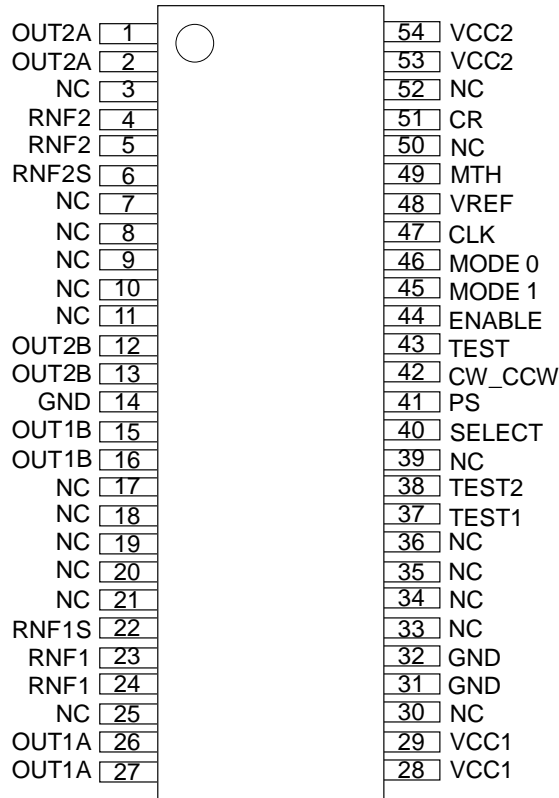

Figure 2. Terminals Configuration Diagram

Block Diagram

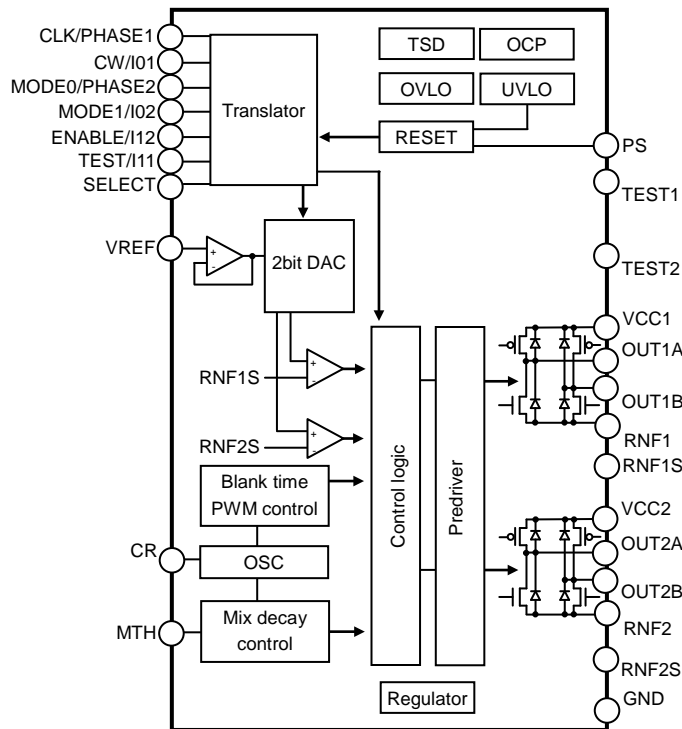

Figure 3. BD63730EFV Block Diagram

## Pin Descriptions

Pin No.	Pin Name	Function	Pin No.	Pin Name	Function	Pin No.	Pin Name	Function
1	OUT2A	H bridge output terminal	19	NC	No connection	37	TEST1	Terminal for enabling TEST mode (TEST1=GND)
2	OUT2A	H bridge output terminal	20	NC	No connection	38	TEST2	Terminal for enabling TEST mode (TEST2=GND)
3	NC	No connection	21	NC	No connection	39	NC	No connection
4	RNF2	Connection terminal of resistor for output current detection	22	RNF1S	Input terminal of current limit comparator	40	SELECT	Input mode select terminal
5	RNF2	Connection terminal of resistor for output current detection	23	RNF1	Connecting terminal of resistor for output current detection	41	PS	Power save terminal
6	RNF2S	Input terminal of current limit comparator	24	RNF1	Connecting terminal of resistor for output current detection	42	CW_CCW /I01	Motor rotating direction setting terminal /VREF division ratio setting terminal
7	NC	No connection	25	NC	No connection	43	TEST /I11	Terminal for enabling TEST mode (TEST=GND) /VREF division ratio setting terminal
8	NC	No connection	26	OUT1A	H bridge output terminal	44	ENABLE /I12	Terminal for enabling output /VREF division ratio setting terminal
9	NC	No connection	27	OUT1A	H bridge output terminal	45	MODE1 /I02	Motor excitation mode setting terminal /VREF division ratio setting terminal
10	NC	No connection	28	VCC1	Power supply terminal	46	MODE0 /PHASE2	Motor excitation mode setting terminal /Phase selection terminal
11	NC	No connection	29	VCC1	Power supply terminal	47	CLK /PHASE1	Clock input terminal for advancing the electrical angle /Phase selection terminal
12	OUT2B	H bridge output terminal	30	NC	No connection	48	VREF	Output current value setting terminal
13	OUT2B	H bridge output terminal	31	GND	Ground terminal	49	MTH	Current decay mode setting terminal
14	GND	Ground terminal	32	GND	Ground terminal	50	NC	No connection
15	OUT1B	H bridge output terminal	33	NC	No connection	51	CR	Connecting terminal of CR for setting chopping frequency
16	OUT1B	H bridge output terminal	34	NC	No connection	52	NC	No connection
17	NC	No connection	35	NC	No connection	53	VCC2	Power supply terminal
18	NC	No connection	36	NC	No connection	54	VCC2	Power supply terminal

**Absolute Maximum Ratings (Ta=25°C)**

Parameter	Symbol	Rated Value	Unit
Supply Voltage	V <sub>CC1,2</sub>	-0.2 to +36.0	V
Power Dissipation	Pd	2.0 <sup>(Note 1)</sup>	W
		6.2 <sup>(Note 2)</sup>	W
Input Voltage For Control Pin	V <sub>IN</sub>	-0.2 to +5.5	V
RNF Maximum Voltage	V <sub>RNF</sub>	0.7	V
Maximum Output Current (Dc)	I <sub>OUT</sub>	3.0 <sup>(Note 3)</sup>	A/Phase
Maximum Output Current (Peak) <sup>(Note 4)</sup>	I <sub>OUTPEAK</sub>	3.5 <sup>(Note 3)</sup>	A/Phase
Operating Temperature Range	Topr	-25 to +85	°C
Storage Temperature Range	Tstg	-55 to +150	°C

(Note 1) 70mmx70mmx1.6mm glass epoxy board. Derate by 16.0mW/°C when operating above Ta=25°C.

(Note 2) 4-layer recommended board. Derate by 49.5mW/°C when operating above Ta=25°C.

(Note 3) Not exceeding Pd, ASO, or Tjmax=150°C.

(Note 4) 4 Pulse width tw≤1ms, duty 20%.

**Caution:** Operating the IC over its absolute maximum ratings may damage the IC. The damage can either be a short circuit between pins or an open circuit between pins and the internal circuitry. Therefore, it is important to consider circuit protection measures, such as adding a fuse, in case the IC is operated over its absolute maximum ratings.

**Recommended Operating Conditions (Ta= -25 to +85°C)**

Parameter	Symbol	Rated Value	Unit
Supply Voltage	V <sub>CC1,2</sub>	19 to 28	V
Maximum Output Current (DC)	I <sub>OUT</sub>	2.7 <sup>(Note 5)</sup>	A/ Phase

(Note 5) Not exceeding Pd, ASO or Tj=150°C

Electrical Characteristics (Unless otherwise specified Ta=25°C, V<sub>CC1,2</sub>=24V)

Parameter	Symbol	Specification			Unit	Conditions
		Minimum	Standard	Maximum		
<b>[Whole]</b>						
Circuit Current at Standby	I <sub>CCST</sub>	-	0.8	2.0	mA	PS=L
Circuit Current	I <sub>CC</sub>	-	2.0	5.0	mA	PS=H, V <sub>REF</sub> =3V
<b>[Control input] (CLK, MODE0)</b>						
H-level Input Voltage	V <sub>IN1H</sub>	2.8	-	-	V	
L-level Input Voltage	V <sub>IN1L</sub>	-	-	0.6	V	
Input Hysteresis Voltage	V <sub>IN1HYS</sub>	-	0.85	-	V	
H-level Input Current	I <sub>IN1H</sub>	35	50	100	μA	V <sub>IN1</sub> =5V
L-level Input Current	I <sub>IN1L</sub>	-10	0	-	μA	V <sub>IN1</sub> =0V
<b>[Control input] (CW, MODE1, ENABLE, TEST, PS, SELECT)</b>						
H-level Input Voltage	V <sub>IN2H</sub>	2.0	-	-	V	
L-level Input Voltage	V <sub>IN2L</sub>	-	-	0.8	V	
H-level Input Current	I <sub>IN2H</sub>	35	50	100	μA	V <sub>IN2</sub> =5V
L-level Input Current	I <sub>IN2L</sub>	-10	0	-	μA	V <sub>IN2</sub> =0V
<b>[Output (OUT1A, OUT1B, OUT2A, OUT2B)]</b>						
Output ON-Resistance	R <sub>ON</sub>	-	0.40	0.52	Ω	I <sub>OUT</sub> = ±2.5A (Sum of upper and lower)
Output Leak Current	I <sub>LEAK</sub>	-	-	10	μA	
<b>[Current control]</b>						
RNFxS Input Current	I <sub>RNFS</sub>	-2.0	-0.1	-	μA	RNFxS=0V
RNFx Input Current	I <sub>RNF</sub>	-40	-20	-	μA	RNFx=0V
VREF Input Current	I <sub>VREF</sub>	-2.0	-0.1	-	μA	V <sub>REF</sub> =0V
VREF Input Voltage Range	V <sub>VREF</sub>	0	-	3.0	V	
MTH Input Current	I <sub>MTH</sub>	-2.0	-0.1	-	μA	MTH=0V
MTH Input Voltage Range	V <sub>MTH</sub>	0	-	3.5	V	
Minimum ON Time (Blank Time)	t <sub>ONMIN</sub>	0.3	0.9	1.5	μs	C=1000pF, R=39kΩ
Comparator Threshold	V <sub>CTH</sub>	0.57	0.60	0.63	V	V <sub>REF</sub> =3V

**Application Information**  
**Function Explanation**

SELECT Terminal/Input Mode Switching Terminal

This is the terminal to set the input mode.

SELECT	Input mode
L	CLK-IN drive
H	Parallel IN drive

Input mode in the case of CLK-IN drive (SELECT=L)

CLK/Clock Input Terminal for Advancing Electrical Angle

The electrical angle advances by one for each CLK input and only reflected at CLK's rising edge.

Motor misstep will occur if noise is picked up at the CLK terminal, so please design the pattern in such a way that there is no noise being introduced.

MODE0,MODE1/Motor Excitation Mode Setting Terminal

Set the motor excitation mode

MODE0	MODE1	Excitation Mode
L	L	FULL STEP
H	L	HALF STEP A
L	H	HALF STEP B
H	H	QUARTER STEP

Please refer to the P.13, 14 for the timing chart & motor torque vector of various excitation modes.

Unrelated to CLK, change in setting is reflected instantly (refer to P.16).

CW Terminal/Motor Rotating Direction Setting

Set the motor's rotating direction. Change in setting is reflected at the CLK rising edge immediately after the change in setting (refer to P.15)

CW	Rotating direction
L	Clockwise (CH2's current is outputted with a phase lag of 90°in regard to CH1's current)
H	Counter Clockwise(CH2's current is outputted with a phase lead of 90°in regard to CH1's current)

ENABLE Terminal/Output Enable Terminal

Turns ON or OFF all output transistors (motor output is open).

When ENABLE=L, input to CLK is blocked, and phase advance operation of internal translator circuit is stopped.

However, during excitation mode (MODE0, MODE1) switch when ENABLE=L, setting ENABLE=L→H resets the IC and the new excitation mode will be applied (See P.16).

ENABLE	Motor Output
L	OPEN (electrical angle retained)
H	ACTIVE

PS/Power Save Terminal

Setting PS=L will cause the circuit to enter standby state and make motor output OPEN. In standby state, translator circuit, and electrical angle are initialized.

Please take note that there is a delay of 40μs (max) before returning from standby state to normal state then the motor output becomes ACTIVE (refer to P.12).

PS	Status
L	Standby state(RESET)
H	ACTIVE

The initial electrical angle of each excitation mode after RESET is as follows (refer to P.13, 14).

Excitation Mode	Initial Electrical Angle
FULL STEP	45°
HALFSTEP A	45°
HALFSTEP B	45°
QUARTER STEP	45°

TEST, TEST1, TEST2 Terminal/Terminal for Inspection

This terminal is used for delivery inspection on IC, and shall be grounded before use.

In addition, malfunctions may be caused by application without grounding.

- ◆ Input mode in the case of Parallel-IN drive (SELECT=H)

PS/Power Save Terminal

Setting PS=L will cause the circuit to enter standby state and make motor output OPEN. In standby state, translator circuit, and electrical angle are initialized.

Please take note that there is a delay of 40μs (max) before returning from standby state to normal state then the motor output becomes ACTIVE (refer to P.12).

PS	Status
L	Standby state(RESET)
H	ACTIVE

PHASE1,PHASE2/Phase Selection Terminal

PHASE1	PHASE2	OUT1A	OUT1B	OUT2A	OUT2B
L	L	L	H	L	H
H	L	H	L	L	H
L	H	L	H	H	L
H	H	H	L	H	L

I01,I02,I11,I12/VREF Division Ratio Setting Terminal

I0x	I1x	Output current level (%)
L	L	100
H	L	67
L	H	33
H	H	0

(I0X, I1X)=(H, H): motor outputs are OPEN.

VCC1,VCC2/Power Supply Terminal

Since the motor's drive current is passing through it, please wire the power supply in such a way that the wire is thick and short, and has low impedance.

VCC voltage may suffer from great fluctuation, so it is necessary to connect a bypass capacitor of about 100μF to 470μF as close to the terminal as possible and adjust in such a way that the VCC voltage is stable. Please increase the capacitance if needed especially when a large current is required or those motors that have great back electromotive force are used.

In addition, for the purpose of reducing the power supply's impedance in wide frequency bandwidth, parallel connection of multi-layered ceramic capacitor of 0.01μF to 0.1μF is recommended. Extreme care must be observed to make sure that the VCC voltage does not exceed the voltage rating even for a moment.

VCC1 & VCC2 are shorted internally, so please be sure to short VCC1 & VCC2 externally when operating. It might cause malfunction or destruction if not shorted externally because of the concentration of current in a certain route. Moreover, in the power supply terminal, there is built-in clamp component for preventing an electrostatic destruction. If a steep pulse or surge voltage of more than that of maximum absolute rating is present, this clamp component operates and as a result there is the danger of destruction, so please be sure that the maximum absolute rating is not to be exceeded. It is effective to mount a Zener diode of about the maximum absolute rating. In addition, the diode for preventing an electrostatic destruction is inserted between VCC terminal and GND terminal, as a result there is the danger of IC destruction if a voltage of reverse polarity is applied between VCC terminal and GND terminal, so please be careful.

GND/Ground Terminal

In order to reduce the noise caused by switching current, and to stabilize the internal reference voltage of IC, please wire in such a way that the wiring impedance from this terminal is made as low as possible to achieve the lowest electrical potential no matter what operating state it may be. Moreover, please design patterns not to have any common impedance with other GND patterns.

OUT1A,OUT1B,OUT2A,OUT2B/H Bridge Output Terminal

Since the motor's drive current is passing through it, please wire in such a way that the wire is thick and short, and has low impedance. It is also effective to add a Schottky diode if the output has a big positive or negative fluctuation when large current is present (i.e. counter electromotive voltage is big). Moreover, in the output terminal, there is a built-in clamp component for preventing an electrostatic destruction. If a steep pulse or surge voltage of more than that of maximum absolute rating is present, this clamp component operates and as a result there is the danger of destruction, so please be sure that the maximum absolute rating is not to be exceeded.

RNF1,RNF2/Connecting terminal of Resistor for Detecting of Output Current

Please connect a resistor of 0.1Ω to 0.3Ω for current detection between this terminal and GND. In view of the power consumption of the current-detecting resistor, please determine the resistor in such a way that  $W=I_{OUT}^2 \cdot R$  [W] does not exceed the power dissipation of the resistor. In addition, please wire in such a way that it has low impedance and does not have impedance common with other GND patterns because motor's drive current passes through RNF terminal to current-detecting resistor to GND. Do not exceed the rating because there is the possibility of circuit malfunction (i.e. RNF voltage exceeded the maximum rating of 0.7V). Moreover, please be careful because if RNF terminal is shorted to GND, large current flows without normal PWM constant current control, then there is the possibility that OCP or TSD will operate. If RNF terminal is open, then there is the danger of malfunction as output current does not flow either, so please do not leave open.

RNF1S,RNF2S/Input Terminal of Current Limit Comparator

In this series, RNFS terminal, which is the input terminal of current limit comparator, is independently arranged in order to decrease the error of current-detecting accuracy caused by the internal wire impedance of RNF terminal. Therefore, connect RNF terminal and RNFS terminal together when using PWM constant current control. In addition, because the wires from RNFS terminal is connected near the current-detecting resistor in the case of interconnection, the lowering of current-detecting accuracy that is caused by the impedance of board pattern between RNF terminal and the current-detecting resistor can be decreased. Moreover, design the pattern in such a way that there is no noise being introduced. In addition, please be careful when terminals of RNF1S & RNF2S are shorted to GND, large current flows without normal PWM constant current control, then there is the possibility that OCP or TSD will operate.

VREF/Output Current Value Setting Terminal

This is the terminal to set the output current value. The output current value can be set by VREF voltage and current-detecting resistor (RNF resistor).

$$\text{Output current } I_{OUT} [\text{A}] = \{V_{REF} [\text{V}] / 5(\text{division ratio inside IC})\} / \text{RNF} [\Omega]$$

Please avoid IC operation with VREF terminal open because if VREF terminal is open, the input is unsettled, and the VREF voltage increases, and then there is the possibility of malfunctions such as the setting current increases, then a large current flows. Please do not exceed 3V because if it exceeds 3V, then there is also the danger that a large current flows in the output and so OCP or TSD will operate. Moreover, please take into consideration the outflow current of 2μA (Max) if configuring by voltage division when selecting the resistance value. The minimum current, which can be controlled by VREF voltage, is determined by motor coil's L & R values and minimum ON time since there is a minimum ON time in PWM drive.

CR/Connecting terminal of CR for Setting Chopping Frequency

This is the terminal to set the chopping frequency of output. Please connect the external C (470p to 1500pF) and R (10k to 200kΩ) between this terminal and GND. Please refer to P11. Please interconnect from external components to GND in such a way that the interconnection does not have impedance in common with other GND patterns. In addition, please design the pattern in such a way that it keeps steep pulses such as square wave away and that there is no noise being introduced. Please mount the two components C and R if operating by PWM constant current control because normal PWM constant current control becomes impossible if CR terminal is open or is biased externally.

MTH/Current Decay Mode-setting Terminal

This is the terminal to set the current decay mode. Current decay mode can be optionally set according to input voltage.

MTH terminal input voltage[V]	Current decay mode
0 to 0.3	SLOW DECAY
0.4 to 1.0	MIX DECAY
1.5 to 3.5	FAST DECAY

Please connect to GND if utilizing SLOW DECAY mode.

Please avoid IC operation with MTH terminal open because if MTH terminal is open, the input is unsettled, and then there is the danger that PWM operation becomes unstable. Moreover, please take into consideration the outflow current of 2μA (Max) if configuring by voltage division when selecting the resistance value.

NC Terminal

This terminal is unconnected electrically with IC internal circuit.

**Thermal Shutdown (TSD)**

This IC has a built-in thermal shutdown circuit for thermal protection. When the IC's chip temperature rises above 175°C (Typ), the motor output becomes OPEN. Also, when the temperature decreases less than 150°C (Typ), it automatically returns to normal operation. However, even when TSD is in operation and heat is continuously added externally, heat overdrive can lead to destruction.

**Over-Current Protection (OCP)**

This IC has a built-in over-current protection circuit as a provision against destruction when the motor outputs are shorted to each other, or VCC-motor output or motor output-GND is shorted. This circuit latches the motor output to OPEN condition when the regulated threshold current flows for 4μs (Typ). It resumes normal operation by re-applying main power supply or a reset of the PS terminal. The over-current protection circuit only aims to prevent the destruction of the IC from irregular situations such as motor output shorts, and is not meant to be used as protection or security for the set. Therefore, sets should not be designed to take into account this circuit's function. After OCP operation, if irregular situations continue and the resume on normal operation by power reactivation or a reset of the PS terminal is carried out repeatedly, then OCP operates repeatedly and the IC may generate heat or otherwise deteriorate. When the L value of the wiring is great due to the wiring being long, after the over-current has flowed and the output terminal voltage jumps up, the absolute maximum values may be exceeded and as a result, there is a possibility of destruction. Also, when current is over the output current rating and under the OCP detection current, the IC can heat up to over  $T_{jmax}=150^{\circ}\text{C}$  and can deteriorate, so current which exceeds the output rating should not be applied.

**Under Voltage Lock Out (UVLO)**

This IC has a built-in under voltage lock out function to prevent false operation such as IC output during power supply under voltage. When the applied voltage to the VCC terminal goes under 15V (Typ), the motor output is set to OPEN. This protection circuit has a 1V (Typ) hysteresis to prevent false operation cause by noise. Please be aware that this circuit does not operate during power save mode. Also, the electrical angle is reset when the UVLO circuit operates during CLK-IN drive mode.

**Over Voltage Lock Out (OVLO)**

This IC has a built-in over voltage lock out function to protect the IC output and the motor during power supply over voltage. When the applied voltage to the VCC terminal goes over 32V (Typ), the motor output is set to OPEN. This protection circuit has a 1V (Typ) hysteresis and a 4μs (Typ) mask time to prevent false operation cause by noise. Although this over voltage locked out circuit is built-in, there is a possibility of destruction if the absolute maximum value for power supply voltage is exceeded. Please be aware that this circuit does not operate during power save mode.

**Ghost Supply Prevention (protects against malfunction when power supply is disconnected)**

If a signal from logic input (e.g. MTH, VREF) is supplied when there is no power supplied to this IC, there is a function which prevents the false operation via the electrostatic discharge protection diode from these input terminals to VCC or to another IC's power supply.

PWM Constant Current Control

Current Control Operation

When the output transistor is turned ON, the output current increases, and as a result increases the voltage at the current sense resistor. Once the voltage at the RNF pin reaches the voltage value set by the internal 2-bit DAC, and the VREF input voltage, the current limit comparator engages and enters current decay mode. The output is then turned OFF for a period of time determined by the RC time constant connected to the CR pin. The process repeats itself constantly for PWM operation.

Noise-masking Function

In order to avoid misdetection of output current due to RNF spikes that may occur when the output turns ON, the IC employs an automatic current detection-masking period ( $t_{ONMIN}$ ), during which current detection is disabled immediately after the output transistor is turned ON. This allows for constant-current drive without the need for an external filter. This noise-masking period defines the minimum ON-time for the motor output transistor.

CR Timer

The CR filter connected to the CR pin is repeatedly charged and discharged between the  $V_{CRH}$  and  $V_{CRL}$  levels. The output of the internal comparator is masked while charging from  $V_{CRL}$  to  $V_{CRH}$  in order to cancel noise. As mentioned above, this operation defines the minimum ON-time of the motor output transistor. The CR terminal begins discharging once the voltage reaches  $V_{CRH}$ . When the output current reaches the current limit during this period (i.e. RNF voltage reaches the decay trigger voltage), then the IC enters decay mode. The CR continues to discharge during this period until it reaches  $V_{CRL}$ ; at this point the IC output is switched back ON. The current output, and CR pin begin charging simultaneously.

The CR charge time ( $t_{ONmin}$ ) and discharge time ( $t_{discharge}$ ) are set by external components, according to the following formulas. The sum of  $t_{ONmin}$  and  $t_{discharge}$  yields the chopping period,  $t_{chop}$ .

$$t_{ONMIN} [s] \approx C \cdot R' \cdot R / (R' + R) \cdot \ln [(V_{CR} - 0.4) / (V_{CR} - 1.0)]$$

$$V_{CR} = V \cdot R / (R' + R)$$

Where:

V is the internal regulator voltage 5V(Typ)

R' is the CR terminal internal impedance 5kΩ(Typ)

$$t_{DISCHARGE} [s] \approx C \cdot R \cdot \ln [(1 + \alpha) / 0.4]$$

$\alpha$ : See the right graph.

$$t_{CHOP} [s] \approx t_{ONMIN} + t_{DISCHARGE}$$

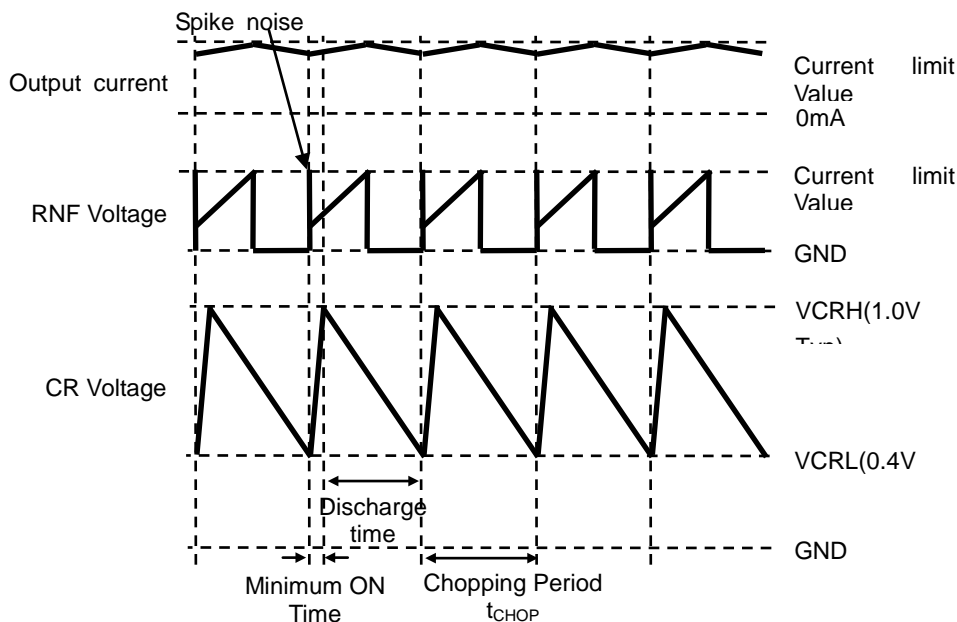
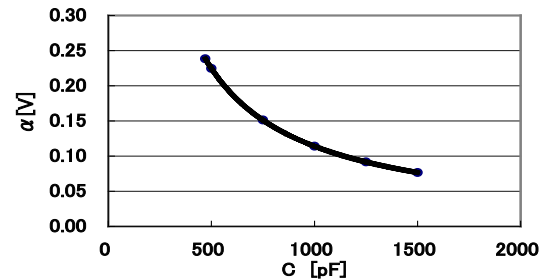

Figure 4. Timing Chart of CR Voltage, RNF Voltage, and Output Current

Attach a resistor of at least 10kΩ to the CR terminal (10kΩ to 200kΩ is recommended) as lower values may keep the RC from reaching the  $V_{CRH}$  voltage level. A capacitor in the range of 470pF to 1500pF is recommended. As the capacitance is increased, the noise-masking period ( $t_{ONMIN}$ ) also increases, and there is a risk that the output current may exceed the current limit threshold due to the internal L and R components of the output motor coil. Also, ensure that the chopping period ( $t_{CHOP}$ ) is not set longer than necessary doing so will increase the output ripple, in effect decreasing the average output current, and yielding lower output rotation efficiency. The optimal value should reduce the motor drive noise while keeping distortion of the output current waveform to a minimum.

Current Decay Mode

The IC allows for a mixed decay mode in which the ratio of fast and slow decay can be optionally set.

The following diagrams show the operating state of each transistor and the regenerative current path during attenuation for each decay mode:

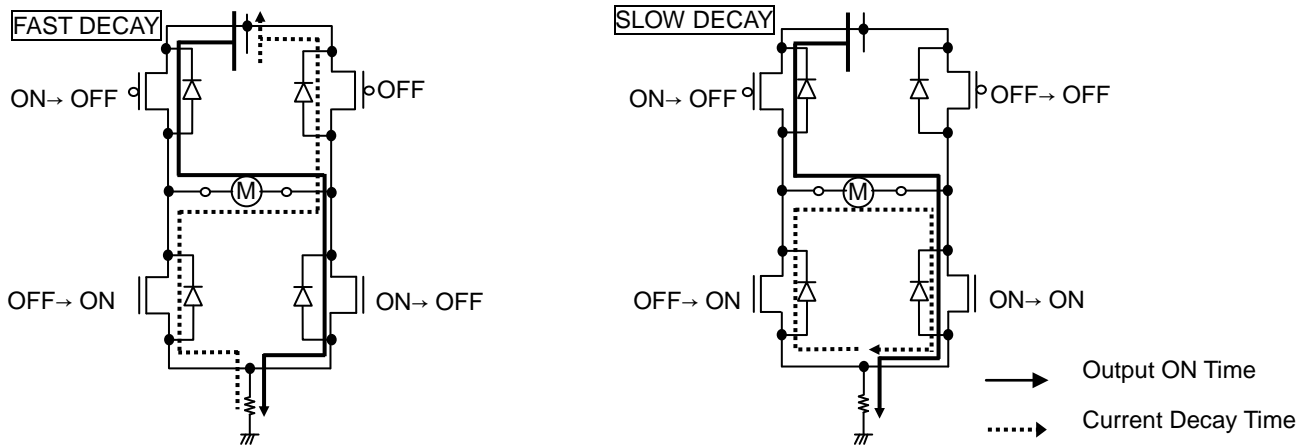

Figure 5. Route of Regenerated Current during Current Decay

The merits of each decay mode are as follows:

SLOW DECAY

During current attenuation, the voltage between motor coils is small and the regeneration current decreases slowly decreasing the output current ripple. This is favorable for keeping motor torque high. However, due to fall-off of current control characteristics in the low-current region, or reverse EMF of the output motors exhibited when using high-pulse-rate half-step or quarter-step modes, the output current increases, distorting the output current waveform, and increasing motor vibration. Thus, this decay mode is most suited to full-step modes, or low-pulse-rate half-step or quarter-step modes.

FAST DECAY

Fast decay decreases the regeneration current more quickly than slow decay, greatly reducing distortion of the output current waveform. However, fast decay yields a larger output current ripple, in effect decreases the overall average current running through the motor. This creates two problems: first, the motor torque decreases. Increasing the current limit value can help eliminate this problem, but the rated output current must be taken into consideration; second, the power loss within the motor increases and thereby produces more heat. If neither of these problems is of concern, then fast decay can be used for high-pulse rate half- or quarter-step drive.

Additionally, this IC allows for a mixed decay mode that can help improve problems that arise from using fast or slow decay mode. In this mode, the IC switches automatically between slow and fast decay, improving the current control characteristics without increasing the output current ripple. Mixed decay mode operates by splitting the decay period into two sections, the first X% ( $t_1-t_2$ ) operates the IC in slow decay mode, and the remainder ( $t_2-t_3$ ) operates in fast decay mode. However, if the output current (i.e. the voltage on the RNF pin) does not reach the set current limit during the first X% ( $t_1-t_2$ ) decay period, the IC operates in fast decay mode only.

MTH voltage [V]	Current decay mode
0 to 0.3	SLOW DECAY
0.4 to 1.0	MIX DECAY
1.5 to 3.5	FAST DECAY

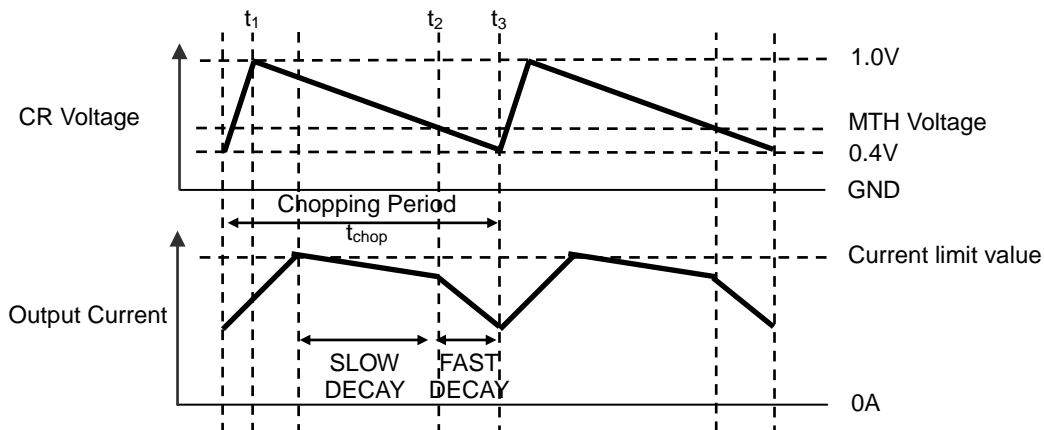

Figure 6. Relation between CR Terminal Voltage, MTH Voltage, and Output Current during Mixed Decay

**Translator Circuit**

This IC has a built-in translator circuit that can drive stepper motor in CLK-IN mode. The operation of the translator circuit in CLK-IN mode is described below.

**Reset Operation**

The translator circuit is initialized by power ON, Reset function, or PS terminal.

**Initializing Operation when Power Supply is Turned ON**

① If power supply is turned ON at PS=L (Please use this sequence as a general rule)

When power supply is turned ON, the power ON reset function operates and initialized, but as long as it is PS=L, the motor output is in OPEN state. After power supply is turned ON and changing of PS=L→H, the motor output becomes ACTIVE, and the excitation is started at the initial electrical angle. At the time of PS=L→H, there is a delay of 40μs (max) until the motor output becomes ACTIVE.

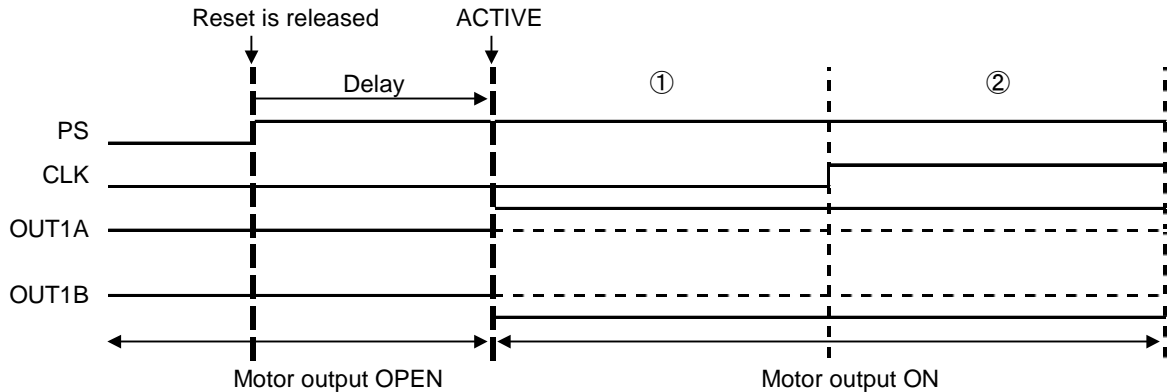

② If power supply is turned ON at PS=H

When power supply is turned ON, the power ON function in IC operates, and initialized before the motor output becomes ACTIVE, and the excitation is started at the initial electrical angle.

**Initializing Operation during Motor Operation**

Please input the reset signal to PS terminal when the translator circuit is initialized during motor operation. (Refer to P.15) But at the time of PS=L→H, there is a delay of 40μs (max) until the motor output becomes ACTIVE, so please be careful.

**Control Input Timing**

Please input signals as shown below since the translator circuit operates at the rising edge of a CLK signal. If the timing is not followed, then there is the possibility that the translator circuit will not operate as expected. In addition, at the time of PS=L→H, there is a delay of 40μs (Max) until the motor output becomes ACTIVE, so within this delay interval there is no phase advance operation even if CLK is inputted.

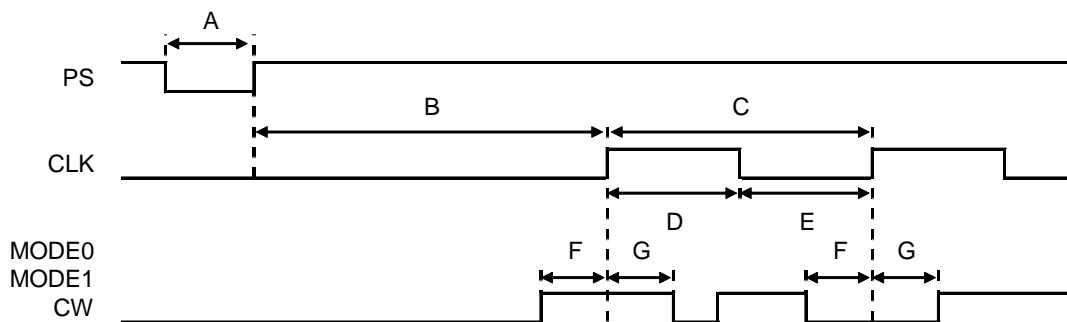

- A: PS minimum input pulse width ····· 20μs
- B: PS rising edge to CLK rising edge input possible maximum delay time ····· 40μs
- C: CLK minimum period ····· 4μs
- D: CLK minimum input H pulse width ····· 2μs
- E: CLK minimum input L pulse width ····· 2μs
- F: MODE0, MODE1, CW set-up time ····· 1μs
- G: MODE0, MODE1, CW hold time ····· 1μs

FULL STEP (MODE0=L, MODE1=L, CW=L, ENABLE=H)

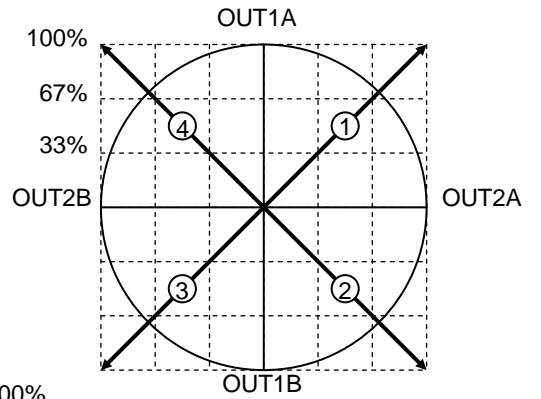
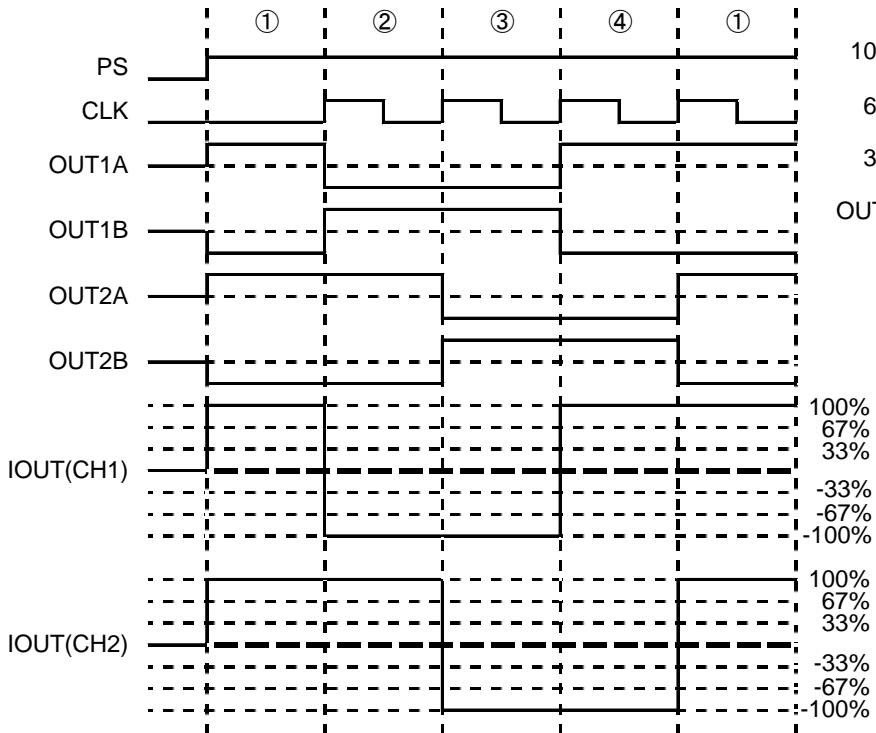

4CLK = Electrical angle 360°

HALF STEP A (MODE0=H, MODE1=L, CW=L, ENABLE=H)

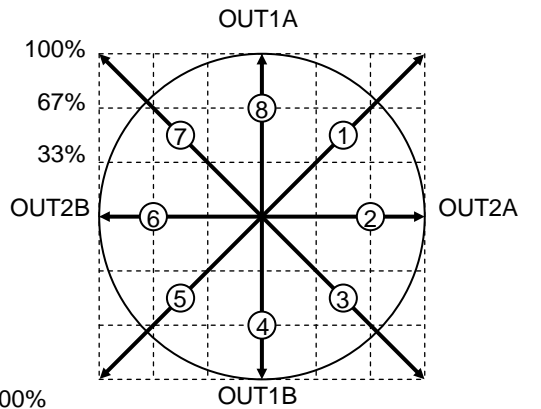
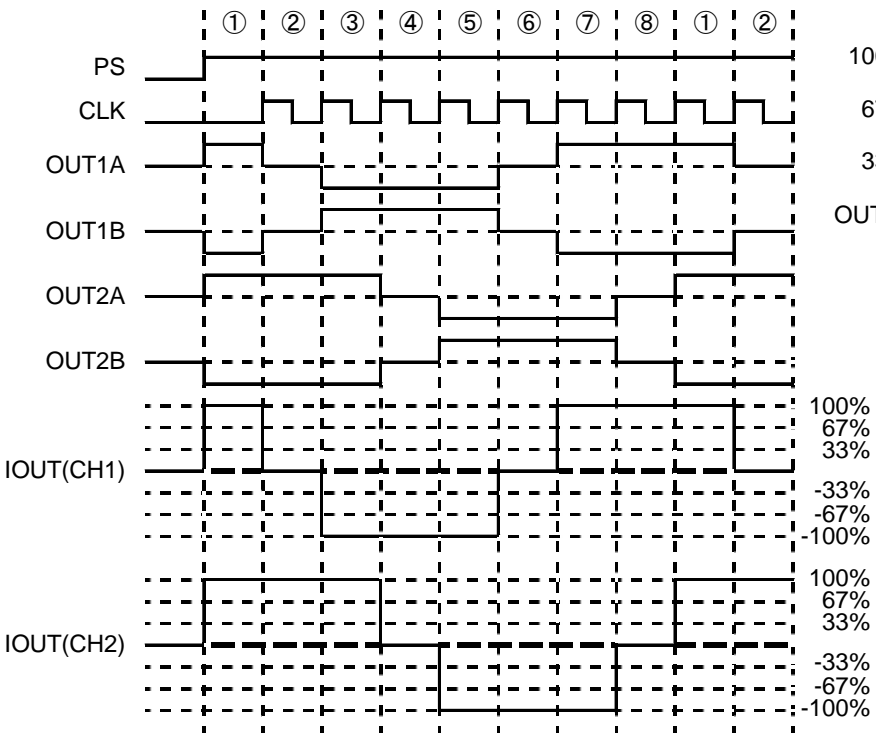

8CLK = Electrical angle 360°

HALF STEP B(MODE0=L, MODE1=H, CW=L, ENABLE=H)

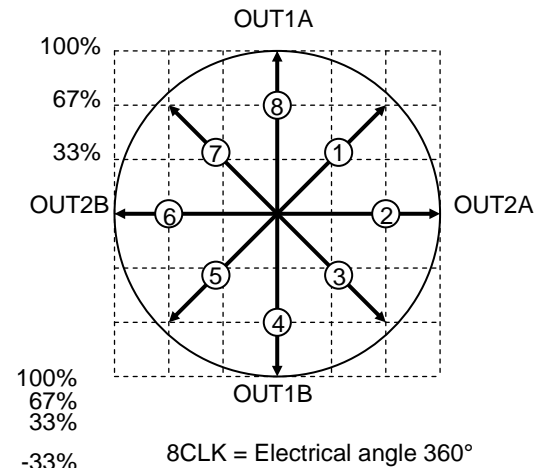
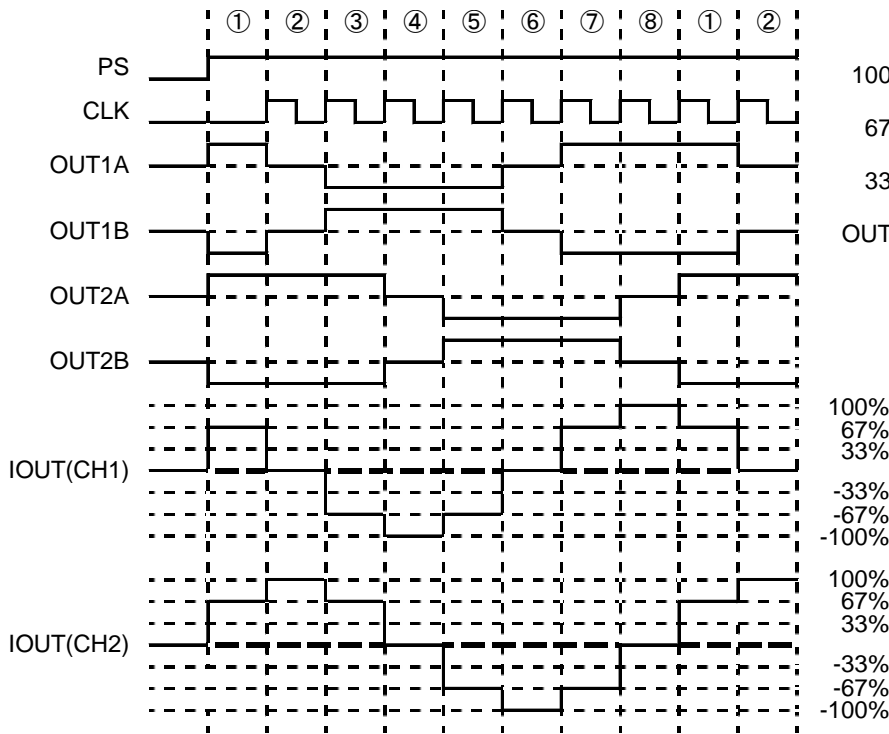

QUARTER STEP(MODE0=H, MODE1=H, CW=L, ENABLE=H)

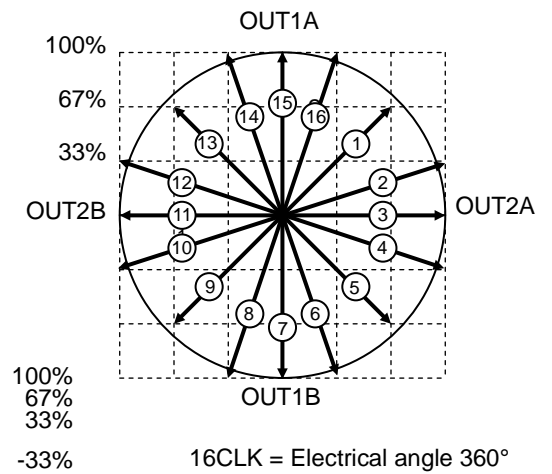
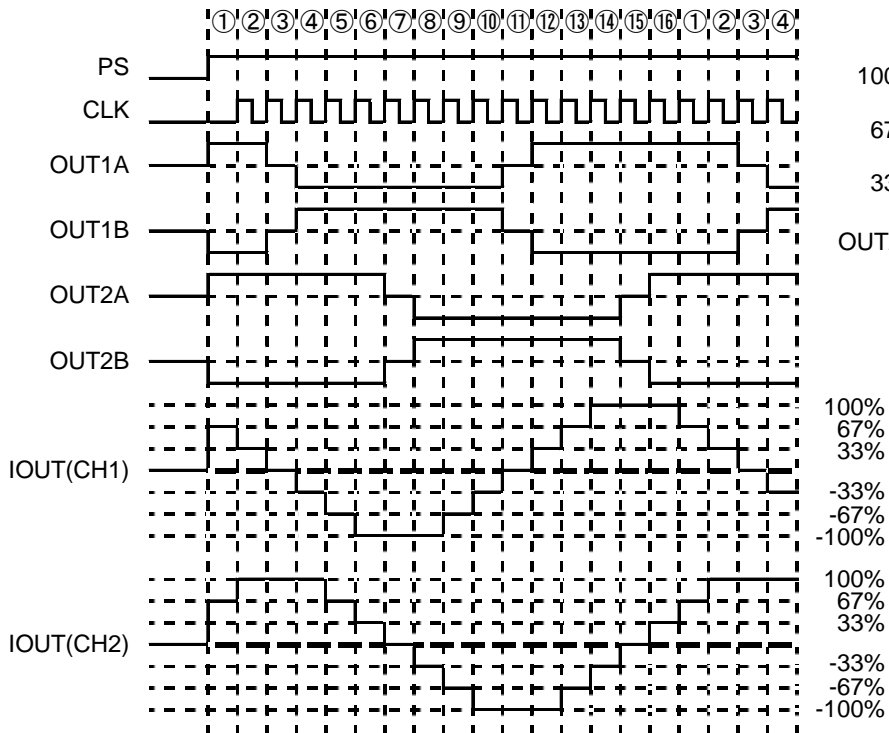

Reset Timing Chart (QUARTER STEP, MODE0=H, MODE1=H, CW=L, ENABLE=H)

If the terminal PS is set to L, the reset operation is done regardless of other input signals then resets the translator circuit while motor is working. At this time, IC internal circuit enters standby mode, and makes the motor output OPEN.

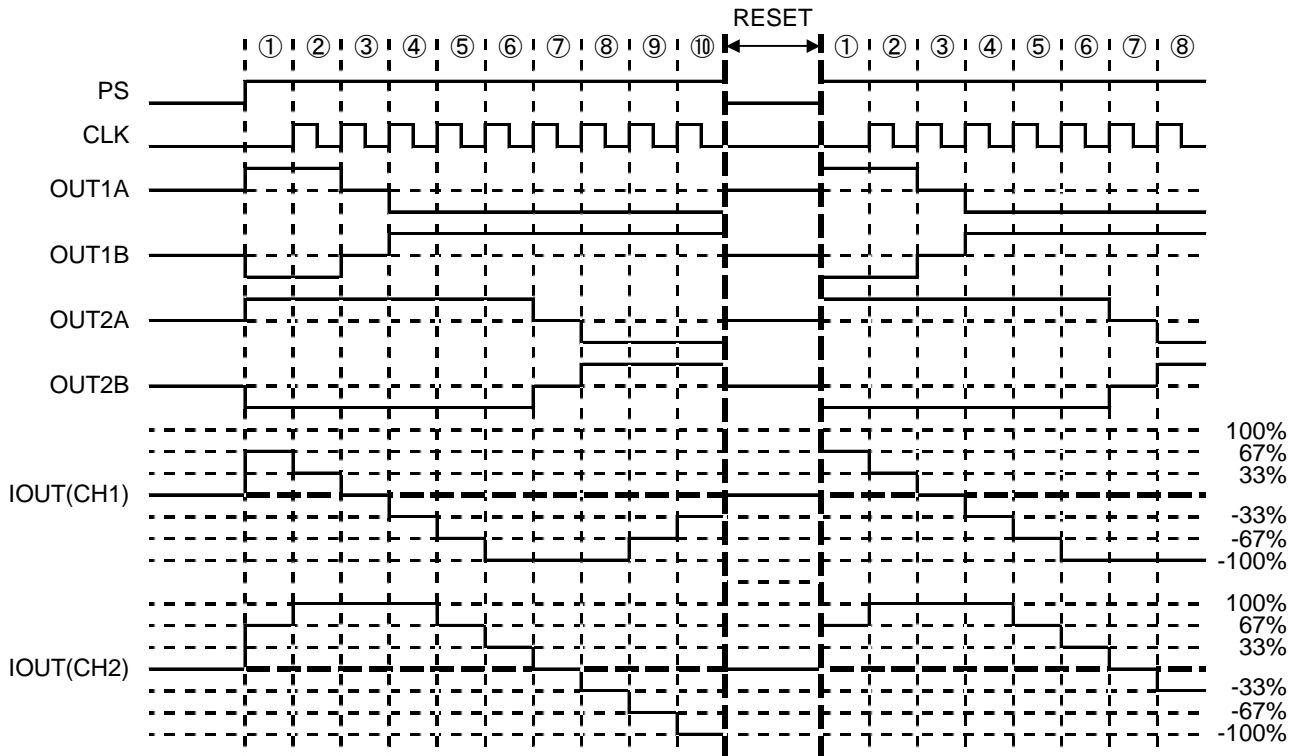

CW Switch Timing Chart (FULL STEP, MODE0=L, MODE1=L, ENABLE=H)

The switching of CW is reflected at the rising edge of the CLK. However, depending on the state of the motor output at the switch, the motor cannot follow even if the control on driver side corresponds and there are possibilities of step-out or misstep in motor. So please consider the sequence of the switch sufficiently.

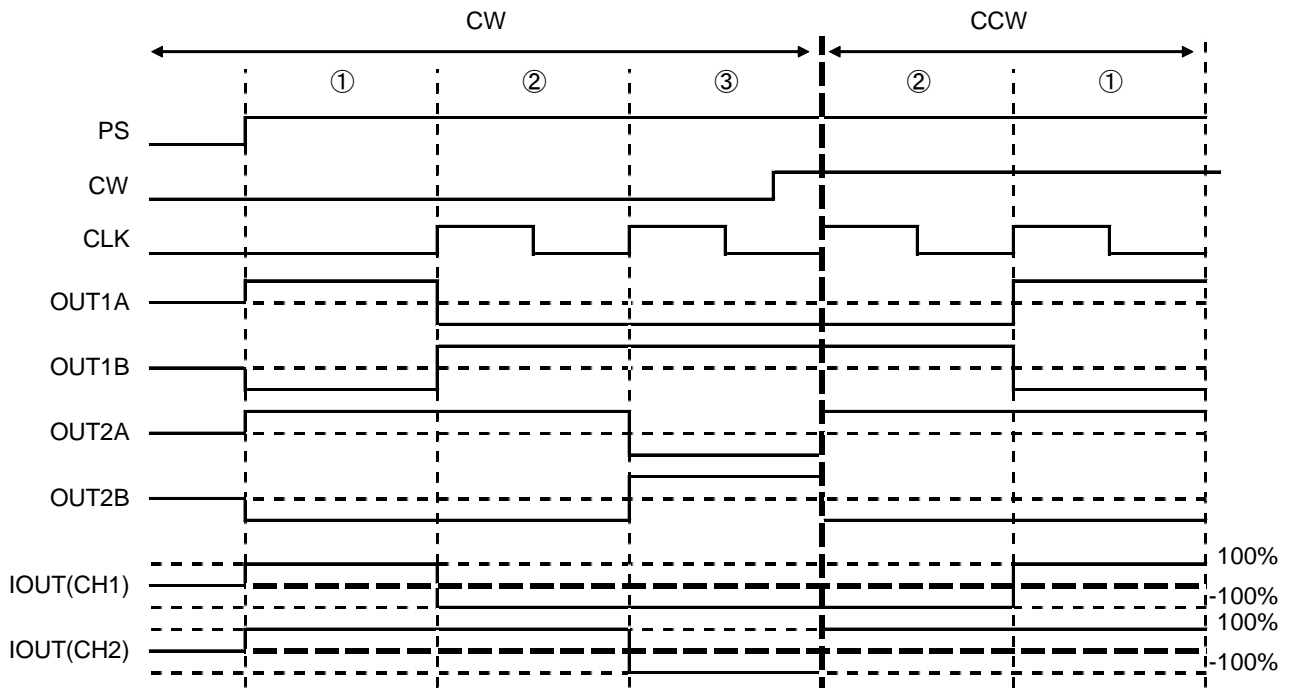

ENABLE Switch Timing Chart (FULL STEP, MODE0=L, MODE1=L, ENABLE=H)

The switching of ENABLE signal is reflected regardless of other input signals.

When ENABLE=L, the motor output becomes OPEN and the electrical angle won't advance because the translator circuit stops, and CLK input is cancelled. Therefore, the previous state will resume after ENABLE=L→H. Excitation mode (MODE0, MODE1) can be switched within ENABLE=L interval. When excitation mode is switched within ENABLE=L interval, restoring of the excitation mode is done after ENABLE=L→H.

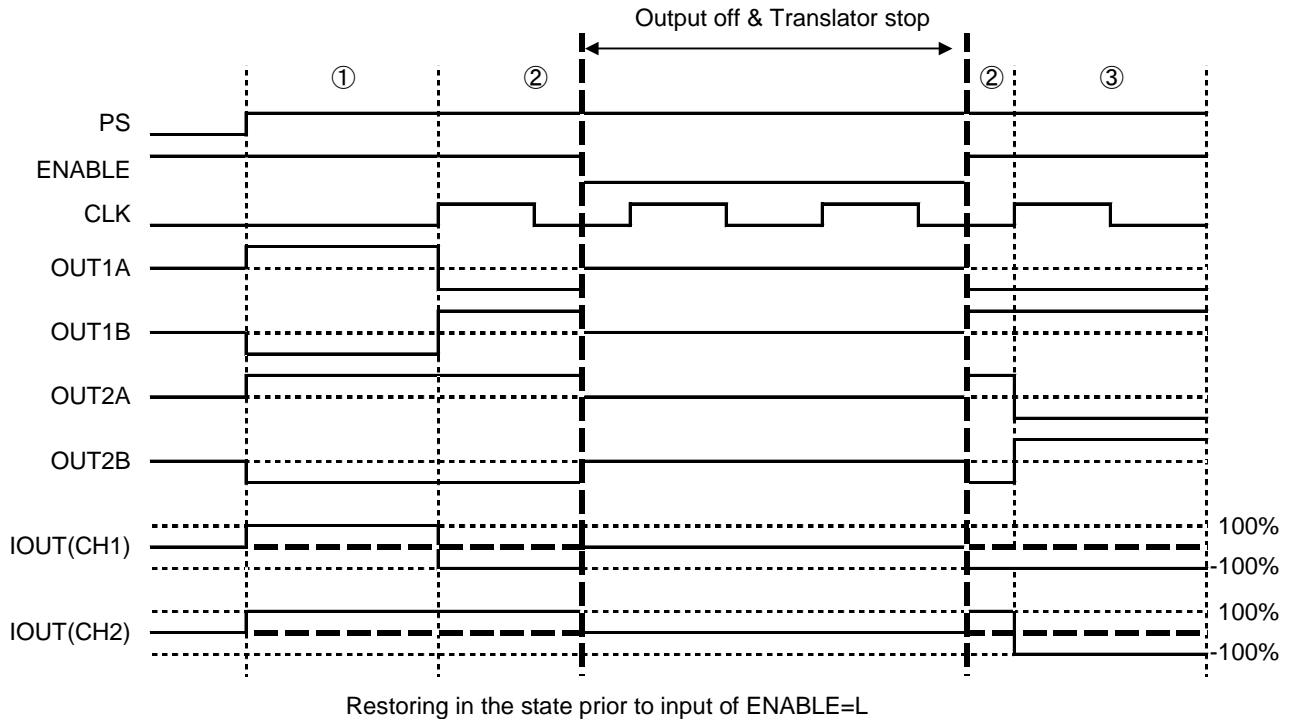

Switching of Motor Excitation Mode

The switching of the excitation mode can be done regardless of the CLK signal at the same time as changing of the signal MODE0 and MODE1. The following built-in function can prevent motor out-of-step caused by discrepancies of torque vector of transitional excitations during switch between excitation modes. However, due to operation state of motor during switch, motor may not act following control on IC side of controller, and thereby lead to out-of-step or miss step. Therefore, switch sequence shall be evaluated sufficiently before any decision.

Cautions of Bidirectional Switch of CW and Excitation Modes (MODE0,MODE1)

As shown in the Figure below, the area between the end of reset discharge (PS=L→H) and beginning of the first CLK signal input is defined as interval A, while the area post the end of the first CLK signal input is defined as interval B.

Interval A

=> For CW, no limitation is applied on switch of excitation mode.

Interval B

=> In CLK1 period, or within ENABLE=L interval, CW and excitation mode can't be switched together.

Violation of this restriction may lead to false step (with one extra leading phase) or out-of-step.

Therefore, in case that CW and excitation modes are switched simultaneously, PS terminal must be input with reset signal. Then start to operate in interval A before carrying out such bidirectional switch.

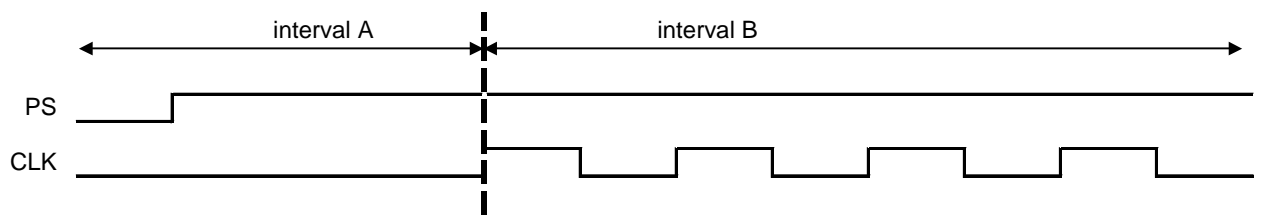

**PARALLEL-IN Drive Mode**

It is possible to drive stepping motor with FULL STEP, HALF STEP, and QUARTER STEP by inputting the following motor control signals using PARALLEL-IN drive mode.

Examples of control sequence and torque vector

**FULL STEP**

Controlled by 2 logic signals of PHASE1 & PHASE2

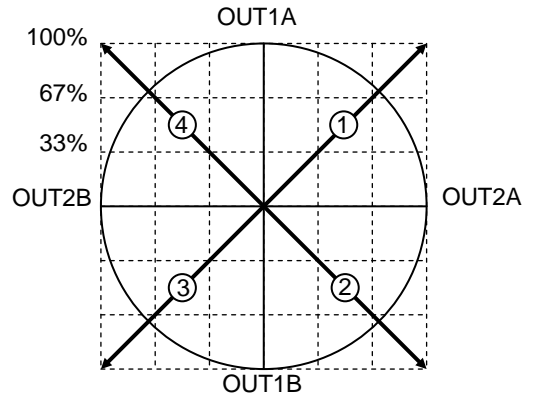
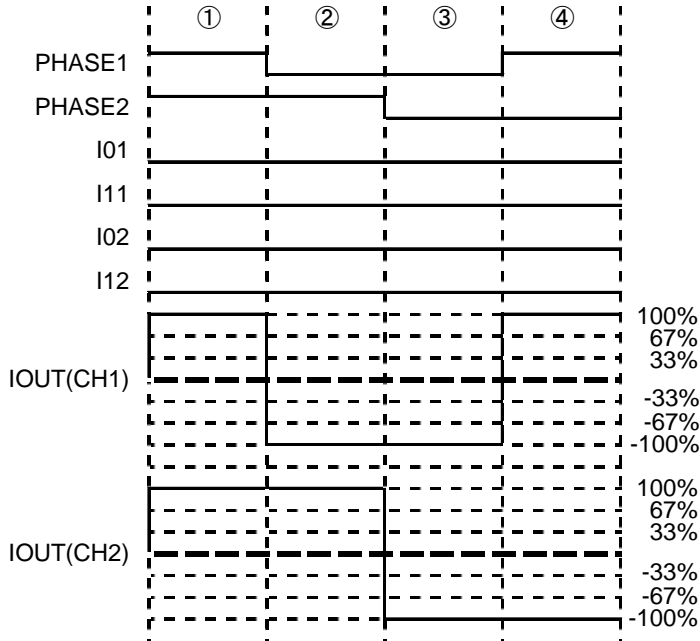

**HALF STEP A**

Controlled by 4 logic signals of PHASE1, PHASE2, I01 (I11), and I02 (I12)

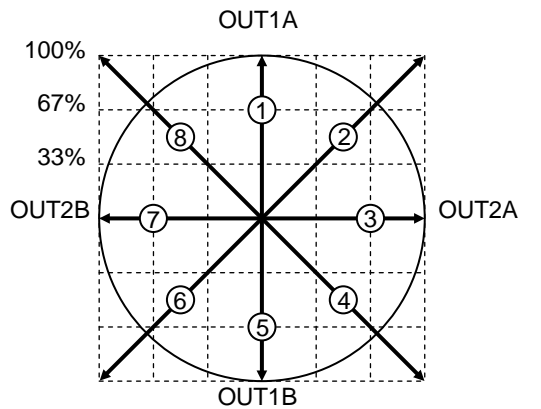
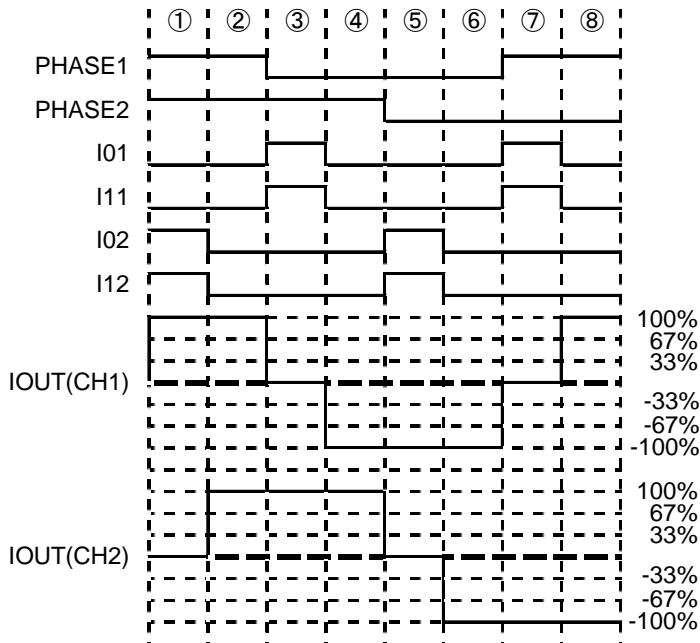

HALF STEP B

Controlled by 6 logic signals of PHASE1, PHASE2, I01, I11, I02, and I12

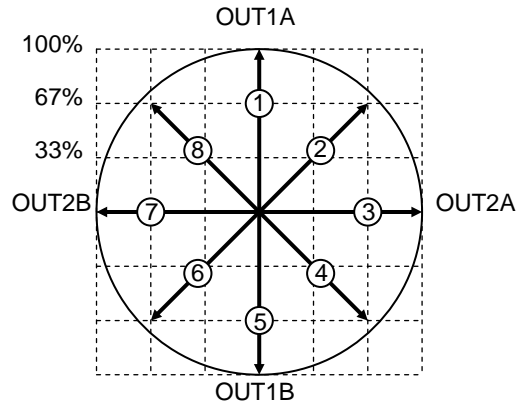
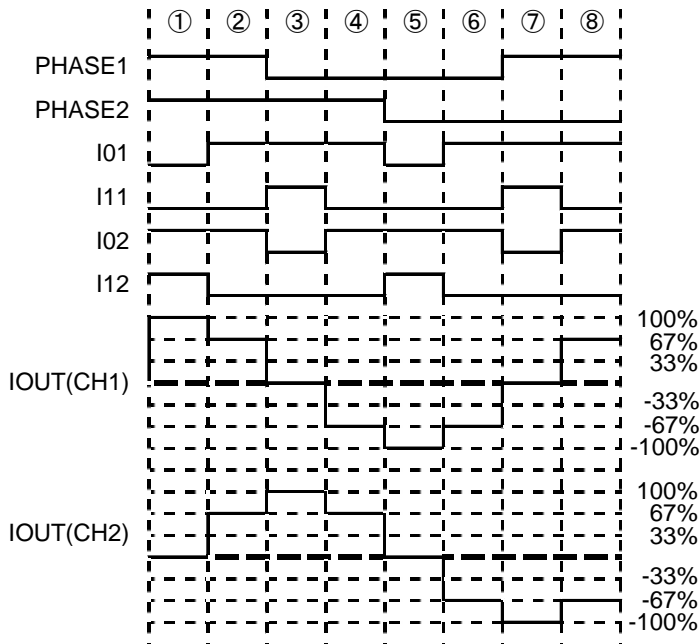

QUARTER STEP

Controlled by 6 logic signals of PHASE1, PHASE2, I01, I11, I02, and I12

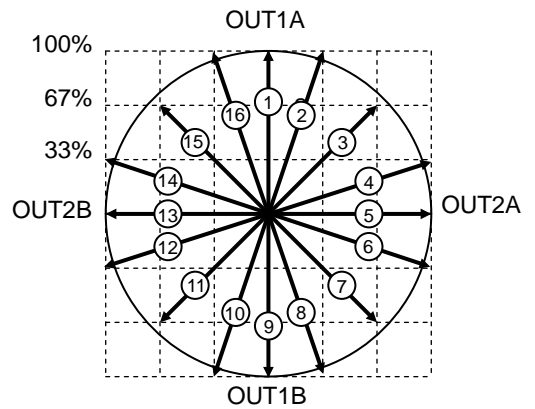
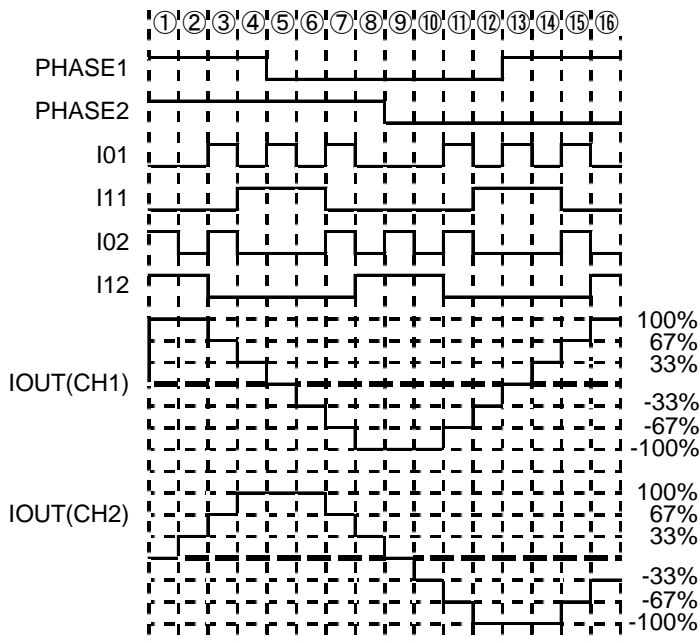

**Power Dissipation**

Please ensure that the IC's chip temperature  $T_j$  is not over  $150^{\circ}\text{C}$ , while considering the IC's power consumption ( $W$ ), package power dissipation ( $P_d$ ), and ambient temperature ( $T_a$ ). When  $T_j=150^{\circ}\text{C}$  is exceeded the functions of the semiconductor do not operate as expected, and problems such as parasitism and leaks occur. Constant use under these circumstances leads to deterioration and eventually destruction of the IC.  $T_{j\text{max}}\leq 150^{\circ}\text{C}$  must be strictly obeyed under all circumstances.

**Thermal Consideration**

The IC's power consumption can be estimated roughly with power supply voltage ( $V_{CC}$ ), circuit current ( $I_{CC}$ ), output ON-Resistance ( $R_{ONH}$ ,  $R_{ONL}$ ), and motor output current value ( $I_{OUT}$ ).

The calculation method during FULL STEP drive, SLOW DECAY mode is shown below:

$$\text{Consumed power of the } V_{CC} [W] = V_{CC} [V] \cdot I_{CC} [A] \quad \dots\dots\dots \textcircled{1}$$

$$\begin{aligned} \text{Consumed power of the output DMOS } [W] = & \frac{(R_{ONH} [\Omega] + R_{ONL} [\Omega]) \cdot I_{OUT} [A]^2 \cdot 2[ch] \cdot \text{on duty}}{\text{During output ON}} \\ & + \frac{(2 \cdot R_{ONL}) \cdot I_{OUT} [A]^2 \cdot 2[ch] \cdot (1 - \text{on\_duty})}{\text{During current decay}} \quad \dots\dots\dots \textcircled{2} \end{aligned}$$

When ON duty:  $\text{PWM on duty} = t_{ON} / (t_{CHOP})$

$t_{ON}$  varies depending on the L and R values of the motor coil and the current set value. Please confirm by actual measurement, or make an approximate calculation.

$t_{CHOP}$  is the chopping period, which depends on the external CR. See P.10 for details.

IC number	Upper PchDMOS ON-Resistance $R_{ONH}[\Omega]$ (Typ)	Lower NchDMOS ON-Resistance $R_{ONL}[\Omega]$ (Typ)
BD63730EFV	0.27	0.13

Consumed power of total IC  $W_{\text{total}} [W] = \textcircled{1} + \textcircled{2}$

Junction Temperature  $T_j = T_a [^{\circ}\text{C}] + \theta_{ja} [^{\circ}\text{C} / \text{W}] \cdot W_{\text{total}} [W]$

However, the thermal resistance value  $\theta_{ja} [^{\circ}\text{C}/\text{W}]$  differs greatly depending on circuit board conditions. Refer to the derating curve on P.21. Also, we are taking measurements of thermal resistance value  $\theta_{ja}$  of actual boards in use. Please feel free to contact our sales department. The calculated values above are only theoretical. For actual thermal design, please perform sufficient thermal evaluation for the application board used, and create the thermal design with enough margin to not exceed  $T_{j\text{max}}=150^{\circ}\text{C}$ . Although unnecessary with normal use, if the IC is to be used under strict heat conditions, please consider inserting an external Schottky diode between the motor output terminal and GND to abate heat from the IC.

**Temperature Monitoring**

In case of CLK-IN drive, there is a way to approximately measure the chip temperature by using the electrostatic discharge protection diode of TEST pin. For PARALLEL-IN drive, the logic terminal (I0x or I1x) can be used when at L state. Temperature monitoring using this method is only for evaluation and experimenting purposes, and must not be used in actual usage conditions.

- Measure the terminal voltage when a current of  $I_{DIODE}=50\mu\text{A}$  passes from the TEST or I0x or I1x terminal to the GND without supplying VCC to the IC. This measurement is the  $V_f$  voltage of the internal diode.
- Measure the temperature characteristics of this terminal voltage.  $V_f$  has a linear negative temperature factor against temperature. With these results of temperature characteristics, chip temperature may be calibrated from the TEST or I0x or I1x terminal voltage.
- Supply VCC, monitor the TEST or I0x or I1x terminal voltage while running the motor, and the chip temperature can be approximated from the results of (2).

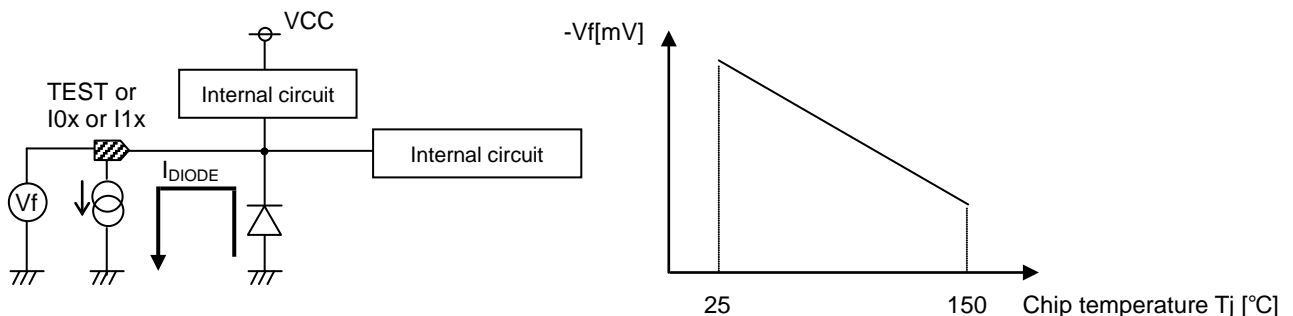

Figure 7. Model Diagram for Measuring Chip Temperature

Example for Application Circuit

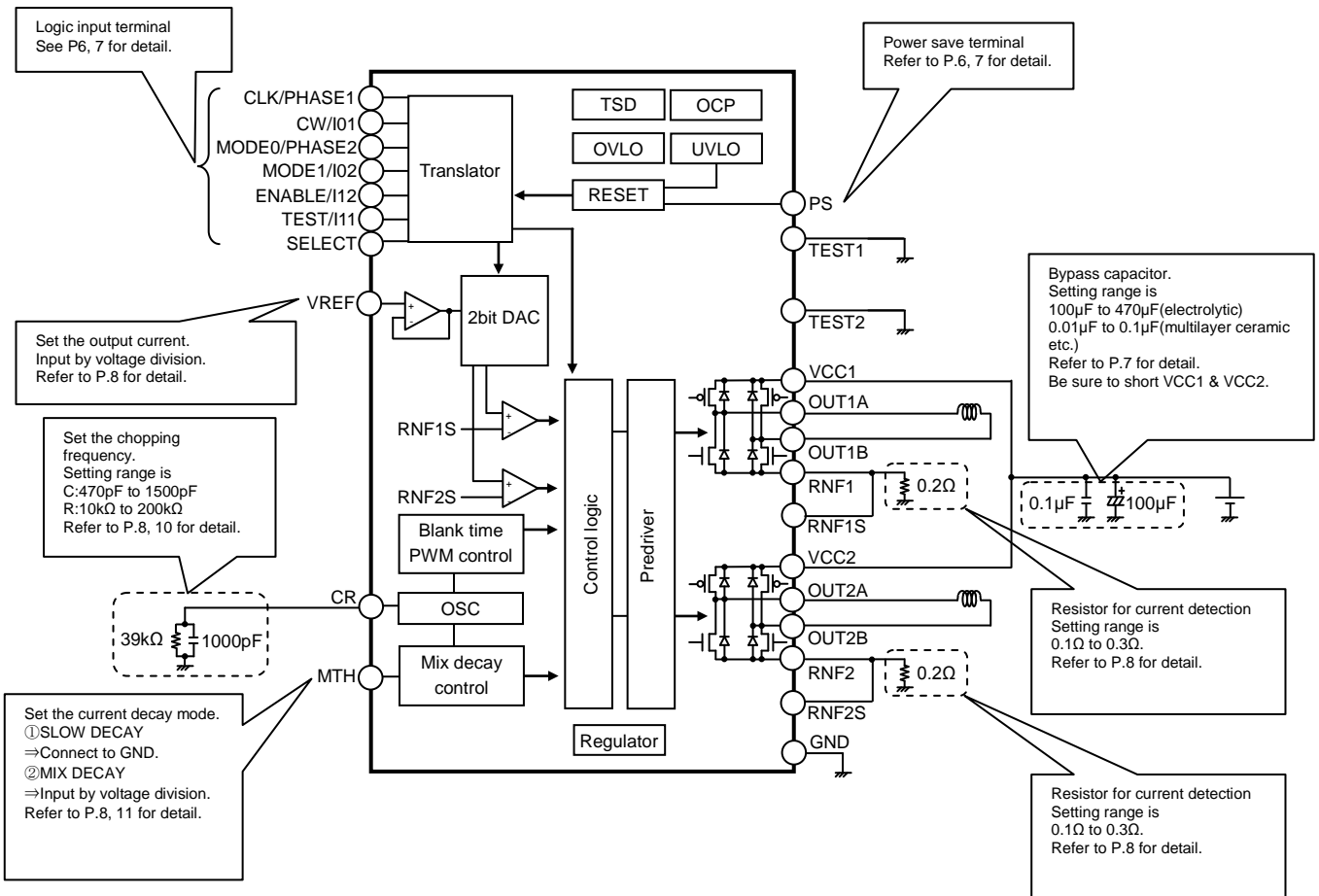
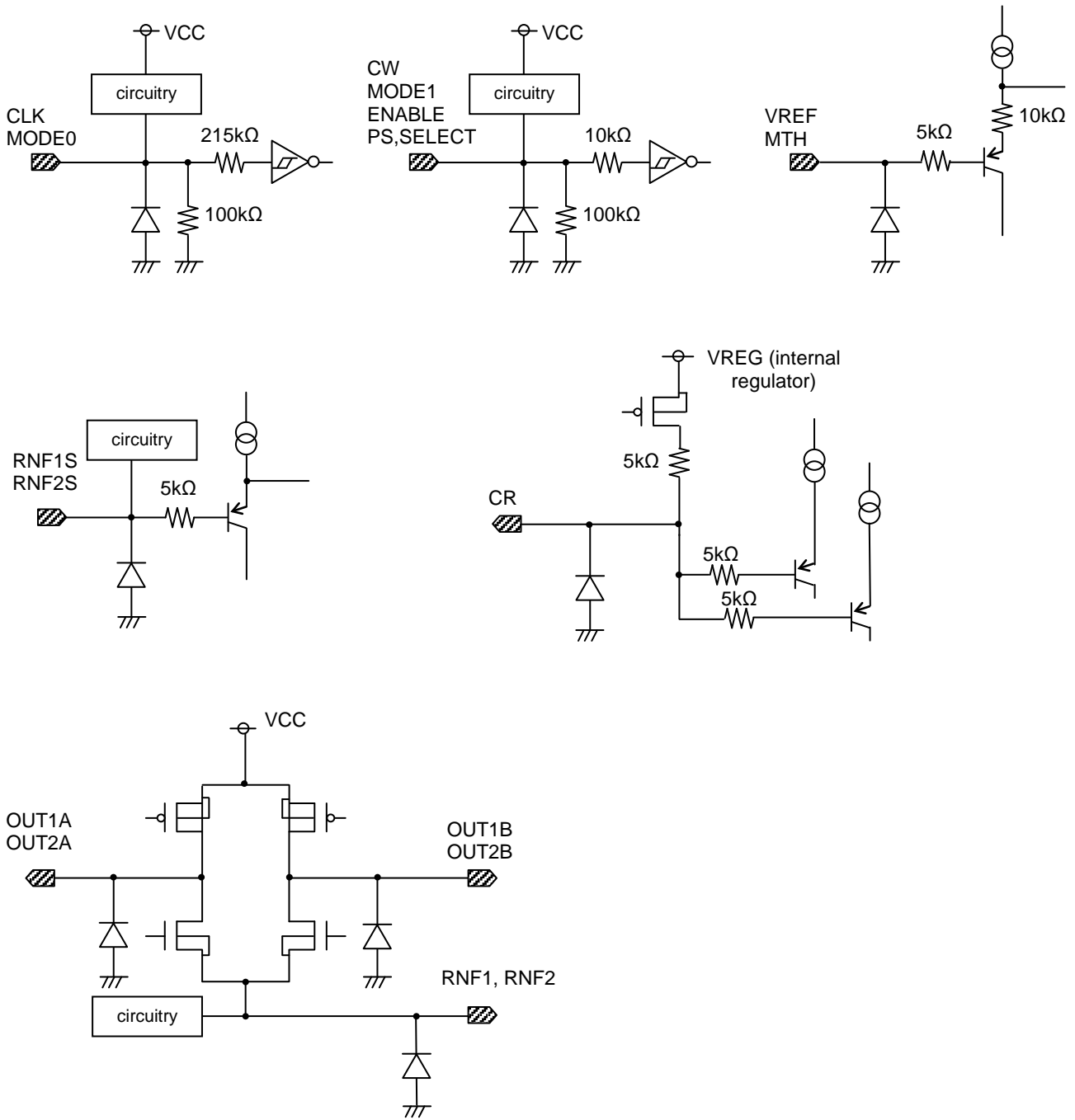

Figure 8. BD63730EFV Block Diagram and Application Circuit Diagram

I/O Equivalent Circuit



## Operational Notes

### 1. Reverse Connection of Power Supply

Connecting the power supply in reverse polarity can damage the IC. Take precautions against reverse polarity when connecting the power supply, such as mounting an external diode between the power supply and the IC's power supply terminals.

### 2. Power Supply Lines

Design the PCB layout pattern to provide low impedance supply lines. Separate the ground and supply lines of the digital and analog blocks to prevent noise in the ground and supply lines of the digital block from affecting the analog block. Furthermore, connect a capacitor to ground at all power supply pins. Consider the effect of temperature and aging on the capacitance value when using electrolytic capacitors.

### 3. Ground Voltage

Ensure that no pins are at a voltage below that of the ground pin at any time, even during transient condition.

### 4. Ground Wiring Pattern

When using both small-signal and large-current ground traces, the two ground traces should be routed separately but connected to a single ground at the reference point of the application board to avoid fluctuations in the small-signal ground caused by large currents. Also ensure that the ground traces of external components do not cause variations on the ground voltage. The ground lines must be as short and thick as possible to reduce line impedance.

### 5. Thermal Consideration

Should by any chance the power dissipation rating be exceeded, the rise in temperature of the chip may result in deterioration of the properties of the chip. The absolute maximum rating of the Pd stated in this specification is when the IC is mounted on a 70mm x 70mm x 1.6mm glass epoxy board. In case of exceeding this absolute maximum rating, increase the board size and copper area to prevent exceeding the Pd rating.

### 6. Recommended Operating Conditions

These conditions represent a range within which the expected characteristics of the IC can be approximately obtained. The electrical characteristics are guaranteed under the conditions of each parameter.

### 7. Inrush Current

When power is first supplied to the IC, it is possible that the internal logic may be unstable and inrush current may flow instantaneously due to the internal powering sequence and delays, especially if the IC has more than one power supply. Therefore, give special consideration to power coupling capacitance, power wiring, width of ground wiring, and routing of connections.

### 8. Operation Under Strong Electromagnetic Field

Operating the IC in the presence of a strong electromagnetic field may cause the IC to malfunction.

### 9. Testing on Application Boards

When testing the IC on an application board, connecting a capacitor directly to a low-impedance output pin may subject the IC to stress. Always discharge capacitors completely after each process or step. The IC's power supply should always be turned OFF completely before connecting or removing it from the test setup during the inspection process. To prevent damage from static discharge, ground the IC during assembly and use similar precautions during transport and storage.

### 10. Inter-pin Short and Mounting Errors

Ensure that the direction and position are correct when mounting the IC on the PCB. Incorrect mounting may result in damaging the IC. Avoid nearby pins being shorted to each other especially to ground, power supply and output pin. Inter-pin shorts could be due to many reasons such as metal particles, water droplets (in very humid environment) and unintentional solder bridge deposited in between pins during assembly to name a few.

### 11. Unused Input Terminals

Input terminals of an IC are often connected to the gate of a MOS transistor. The gate has extremely high impedance and extremely low capacitance. If left unconnected, the electric field from the outside can easily charge it. The small charge acquired in this way is enough to produce a significant effect on the conduction through the transistor and cause unexpected operation of the IC. So unless otherwise specified, unused input terminals should be connected to the power supply or ground line.

**Operational Notes – continued**

**12. Regarding Input Pins of the IC**

This monolithic IC contains P+ isolation and P substrate layers between adjacent elements in order to keep them isolated. P-N junctions are formed at the intersection of the P layers with the N layers of other elements, creating a parasitic diode or transistor. For example (refer to figure below):

When  $GND > Pin\ A$  and  $GND > Pin\ B$ , the P-N junction operates as a parasitic diode.  
 When  $GND > Pin\ B$ , the P-N junction operates as a parasitic transistor.

Parasitic diodes inevitably occur in the structure of the IC. The operation of parasitic diodes can result in mutual interference among circuits, operational faults, or physical damage. Therefore, conditions that cause these diodes to operate, such as applying a voltage lower than the GND voltage to an input pin (and thus to the P substrate) should be avoided.

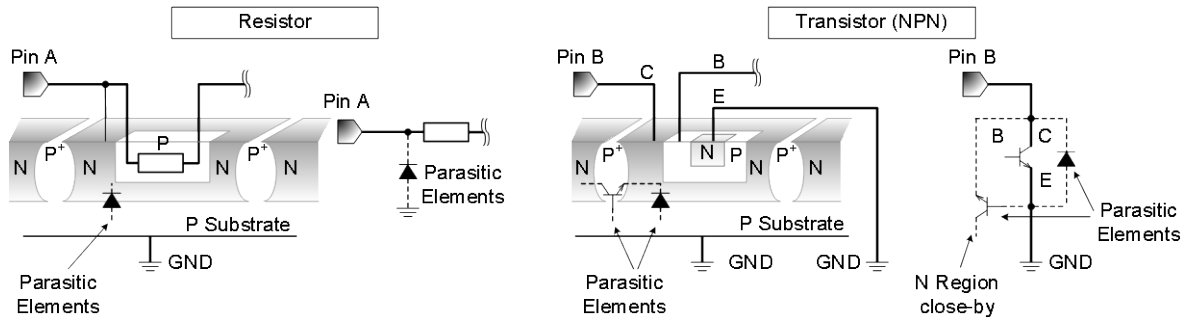

Figure 10. Example of Monolithic IC Structure

**13. Area of Safe Operation (ASO)**

Operate the IC such that the output voltage, output current, and power dissipation are all within the Area of Safe Operation (ASO).

**14. Thermal Shutdown Circuit(TSD)**

This IC has a built-in thermal shutdown circuit that prevents heat damage to the IC. Normal operation should always be within the IC's power dissipation rating. If however the rating is exceeded for a continued period, the junction temperature ( $T_j$ ) will rise which will activate the TSD circuit that will turn OFF all output pins. When the  $T_j$  falls below the TSD threshold, the circuits are automatically restored to normal operation.

Note that the TSD circuit operates in a situation that exceeds the absolute maximum ratings and therefore, under no circumstances, should the TSD circuit be used in a set design or for any purpose other than protecting the IC from heat damage.

**15. Over-Current Protection Circuit (OCP)**

This IC has a built-in overcurrent protection circuit that activates when the output is accidentally shorted. However, it is strongly advised not to subject the IC to prolonged shorting of the output.

**Power Dissipation**

HTSSOP-B54 is designed with heat-remission metal on the backside of IC to perform heat dissipation treatment using through hole from backside. It is possible to increase power dissipation considerably by ensuring sufficient heat-releasing area on both top and back sides such as copper foil. Please note that the power dissipation described below may not be assured without being shorted. The back metal is shorted with the backside of the IC chip that is a GND potential. There is a possibility for malfunction if it is shorted with any potential other than GND, which should be avoided. The back metal should be soldered onto the GND to short. Please be careful that this package is designed to be used after performing heat dissipation treatment on the back metal, and to improve heat dissipation efficiency.

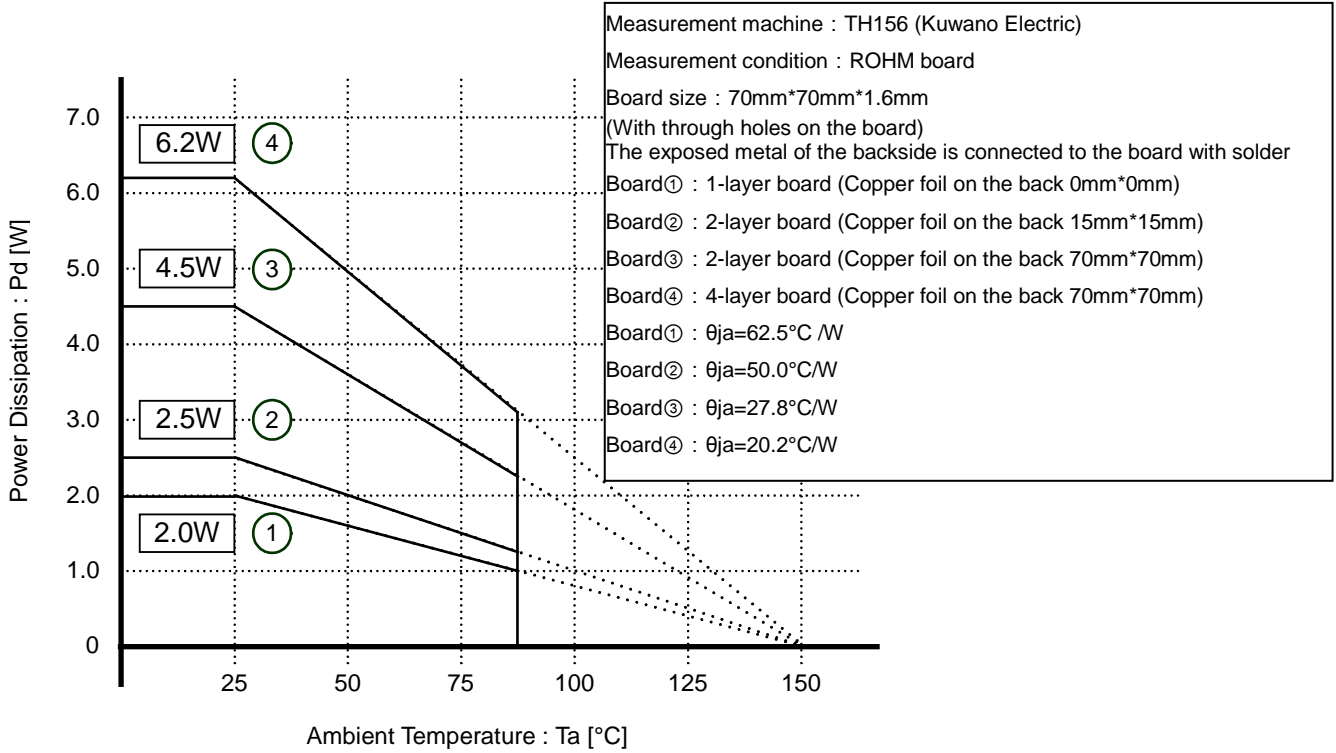
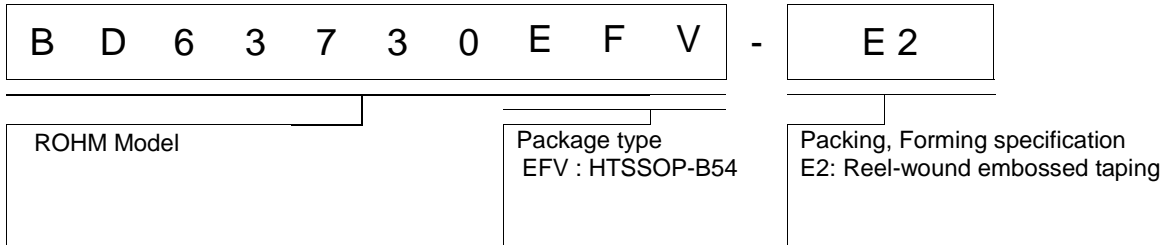
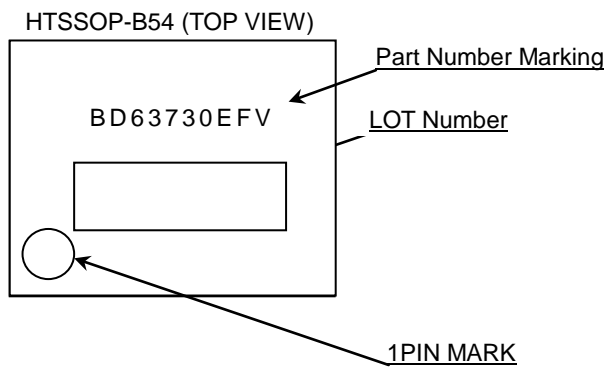

Figure 9. HTSSOP-B54 Derating Curve

Ordering Information



Marking Diagram



Physical Dimension, Tape and Reel Information

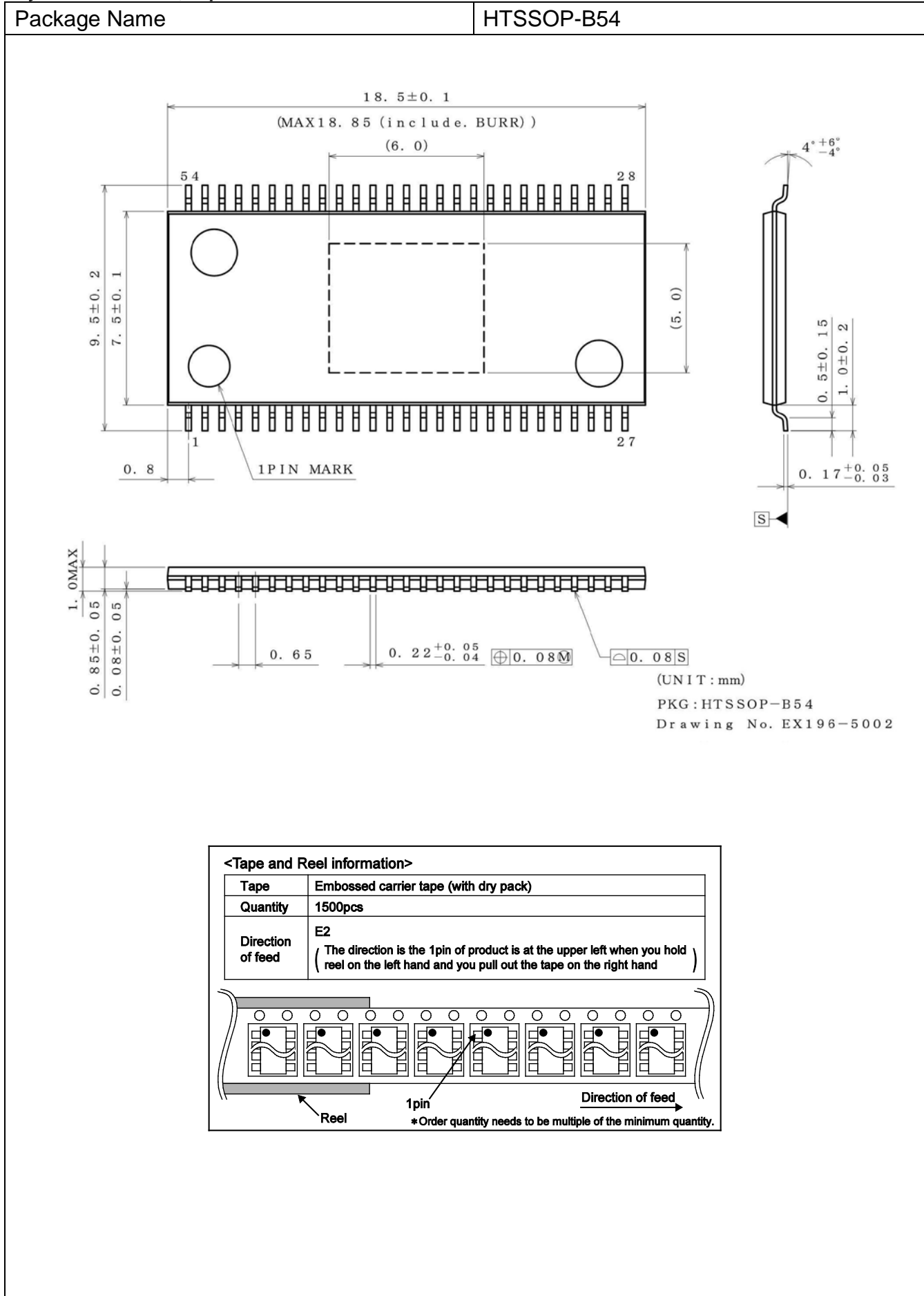

# Notice

## Precaution on using ROHM Products

- Our Products are designed and manufactured for application in ordinary electronic equipments (such as AV equipment, OA equipment, telecommunication equipment, home electronic appliances, amusement equipment, etc.). If you intend to use our Products in devices requiring extremely high reliability (such as medical equipment <sup>(Note 1)</sup>, transport equipment, traffic equipment, aircraft/spacecraft, nuclear power controllers, fuel controllers, car equipment including car accessories, safety devices, etc.) and whose malfunction or failure may cause loss of human life, bodily injury or serious damage to property ("Specific Applications"), please consult with the ROHM sales representative in advance. Unless otherwise agreed in writing by ROHM in advance, ROHM shall not be in any way responsible or liable for any damages, expenses or losses incurred by you or third parties arising from the use of any ROHM's Products for Specific Applications.

(Note1) Medical Equipment Classification of the Specific Applications

JAPAN	USA	EU	CHINA
CLASS III	CLASS III	CLASS II b	CLASS III
CLASS IV		CLASS III	

- ROHM designs and manufactures its Products subject to strict quality control system. However, semiconductor products can fail or malfunction at a certain rate. Please be sure to implement, at your own responsibilities, adequate safety measures including but not limited to fail-safe design against the physical injury, damage to any property, which a failure or malfunction of our Products may cause. The following are examples of safety measures:
  - Installation of protection circuits or other protective devices to improve system safety
  - Installation of redundant circuits to reduce the impact of single or multiple circuit failure
- Our Products are designed and manufactured for use under standard conditions and not under any special or extraordinary environments or conditions, as exemplified below. Accordingly, ROHM shall not be in any way responsible or liable for any damages, expenses or losses arising from the use of any ROHM's Products under any special or extraordinary environments or conditions. If you intend to use our Products under any special or extraordinary environments or conditions (as exemplified below), your independent verification and confirmation of product performance, reliability, etc. prior to use, must be necessary:
  - Use of our Products in any types of liquid, including water, oils, chemicals, and organic solvents
  - Use of our Products outdoors or in places where the Products are exposed to direct sunlight or dust
  - Use of our Products in places where the Products are exposed to sea wind or corrosive gases, including Cl<sub>2</sub>, H<sub>2</sub>S, NH<sub>3</sub>, SO<sub>2</sub>, and NO<sub>2</sub>
  - Use of our Products in places where the Products are exposed to static electricity or electromagnetic waves
  - Use of our Products in proximity to heat-producing components, plastic cords, or other flammable items
  - Sealing or coating our Products with resin or other coating materials
  - Use of our Products without cleaning residue of flux (even if you use no-clean type fluxes, cleaning residue of flux is recommended); or Washing our Products by using water or water-soluble cleaning agents for cleaning residue after soldering
  - Use of the Products in places subject to dew condensation
- The Products are not subject to radiation-proof design.
- Please verify and confirm characteristics of the final or mounted products in using the Products.
- In particular, if a transient load (a large amount of load applied in a short period of time, such as pulse. is applied, confirmation of performance characteristics after on-board mounting is strongly recommended. Avoid applying power exceeding normal rated power; exceeding the power rating under steady-state loading condition may negatively affect product performance and reliability.
- De-rate Power Dissipation (Pd) depending on Ambient temperature (Ta). When used in sealed area, confirm the actual ambient temperature.
- Confirm that operation temperature is within the specified range described in the product specification.
- ROHM shall not be in any way responsible or liable for failure induced under deviant condition from what is defined in this document.

## Precaution for Mounting / Circuit board design

- When a highly active halogenous (chlorine, bromine, etc.) flux is used, the residue of flux may negatively affect product performance and reliability.
- In principle, the reflow soldering method must be used on a surface-mount products, the flow soldering method must be used on a through hole mount products. If the flow soldering method is preferred on a surface-mount products, please consult with the ROHM representative in advance.

For details, please refer to ROHM Mounting specification

### Precautions Regarding Application Examples and External Circuits

1. If change is made to the constant of an external circuit, please allow a sufficient margin considering variations of the characteristics of the Products and external components, including transient characteristics, as well as static characteristics.
2. You agree that application notes, reference designs, and associated data and information contained in this document are presented only as guidance for Products use. Therefore, in case you use such information, you are solely responsible for it and you must exercise your own independent verification and judgment in the use of such information contained in this document. ROHM shall not be in any way responsible or liable for any damages, expenses or losses incurred by you or third parties arising from the use of such information.

### Precaution for Electrostatic

This Product is electrostatic sensitive product, which may be damaged due to electrostatic discharge. Please take proper caution in your manufacturing process and storage so that voltage exceeding the Products maximum rating will not be applied to Products. Please take special care under dry condition (e.g. Grounding of human body / equipment / solder iron, isolation from charged objects, setting of Ionizer, friction prevention and temperature / humidity control).

### Precaution for Storage / Transportation

1. Product performance and soldered connections may deteriorate if the Products are stored in the places where:
  - [a] the Products are exposed to sea winds or corrosive gases, including Cl<sub>2</sub>, H<sub>2</sub>S, NH<sub>3</sub>, SO<sub>2</sub>, and NO<sub>2</sub>
  - [b] the temperature or humidity exceeds those recommended by ROHM
  - [c] the Products are exposed to direct sunshine or condensation
  - [d] the Products are exposed to high Electrostatic
2. Even under ROHM recommended storage condition, solderability of products out of recommended storage time period may be degraded. It is strongly recommended to confirm solderability before using Products of which storage time is exceeding the recommended storage time period.
3. Store / transport cartons in the correct direction, which is indicated on a carton with a symbol. Otherwise bent leads may occur due to excessive stress applied when dropping of a carton.
4. Use Products within the specified time after opening a humidity barrier bag. Baking is required before using Products of which storage time is exceeding the recommended storage time period.

### Precaution for Product Label

QR code printed on ROHM Products label is for ROHM's internal use only.

### Precaution for Disposition

When disposing Products please dispose them properly using an authorized industry waste company.

### Precaution for Foreign Exchange and Foreign Trade act

Since our Products might fall under controlled goods prescribed by the applicable foreign exchange and foreign trade act, please consult with ROHM representative in case of export.

### Precaution Regarding Intellectual Property Rights

1. All information and data including but not limited to application example contained in this document is for reference only. ROHM does not warrant that foregoing information or data will not infringe any intellectual property rights or any other rights of any third party regarding such information or data. ROHM shall not be in any way responsible or liable for infringement of any intellectual property rights or other damages arising from use of such information or data.:
2. No license, expressly or implied, is granted hereby under any intellectual property rights or other rights of ROHM or any third parties with respect to the information contained in this document.

### Other Precaution



1. This document may not be reprinted or reproduced, in whole or in part, without prior written consent of ROHM.
2. The Products may not be disassembled, converted, modified, reproduced or otherwise changed without prior written consent of ROHM.
3. In no event shall you use in any way whatsoever the Products and the related technical information contained in the Products or this document for any military purposes, including but not limited to, the development of mass-destruction weapons.
4. The proper names of companies or products described in this document are trademarks or registered trademarks of ROHM, its affiliated companies or third parties.

**General Precaution**

1. Before you use our Products, you are requested to carefully read this document and fully understand its contents. ROHM shall not be in any way responsible or liable for failure, malfunction or accident arising from the use of any ROHM's Products against warning, caution or note contained in this document.
2. All information contained in this document is current as of the issuing date and subject to change without any prior notice. Before purchasing or using ROHM's Products, please confirm the latest information with a ROHM sales representative.
3. The information contained in this document is provided on an "as is" basis and ROHM does not warrant that all information contained in this document is accurate and/or error-free. ROHM shall not be in any way responsible or liable for any damages, expenses or losses incurred by you or third parties resulting from inaccuracy or errors of or concerning such information.

## Looking for pricing, stock, or lifecycle information?

Click below to explore more details on WIN SOURCE:

-  [View BD63730EFV-E2 on WIN SOURCE](#)
-  [Rohm Semiconductor](#) Information

## Optimize Your Supply Chain with WIN SOURCE Solutions

-  Global Sourcing Solution
-  Obsolete Management
-  Cost Control Management
-  Shortage Management
-  Alternative Solution
-  Excess Inventory Management