



**THE DATASHEET OF
BD63401EFV-E2**



40 V Stepping Motor Driver

BD63401EFV

General Description

BD63401EFV is a bipolar low-consumption driver that driven by PWM current. Rated power supply voltage of the device is 40 V, and rated output current is 1.35 A. PARA-IN driving mode is adopted for input interface. In addition, the power supply can be driven by one single system, which simplifies the design.

Features

- Rated Output Current 1.35 A
- Low ON Resistance DMOS Output
- PARA-IN Drive Mode
- PWM Constant Current (other oscillation)
- Built-in Spike Noise Cancel Function (external noise filter is unnecessary)
- FULL STEP, HALF STEP Functionality
- Current Decay Mode is SLOW DECAY
- Power Save Function
- Built-in Logic Input Pull-down Resistor
- Thermal Shutdown Circuit (TSD)
- Over-current Protection Circuit (OCP)
- Under Voltage Lock Out Circuit (UVLO)
- Over Voltage Lock Out Circuit (OVLO)
- Protects against malfunction when power supply is disconnected (Ghost Supply Prevention function)
- Microminiature, Ultra-thin and High Heat-radiation (exposed metal type) Package

Application

- Sewing Machine, PPC, Multi-function Printer, Laser Beam Printer, Ink-jet Printer, Monitoring Camera, WEB Camera, Photo Printer, FAX, Scanner, Mini Printer, Toy and Robot

Key Specifications

- Range of Power Supply Voltage 8 V to 33 V
- Rated Output Current 1.35 A
- Range of Operating Temperature -25 °C to +85 °C
- Output ON Resistance 1.0 Ω (Typ)
(total of upper and lower resistors)

Package

HTSSOP-B20

W (Typ) x D (Typ) x H (Max)
6.50 mm x 6.40 mm x 1.00 mm

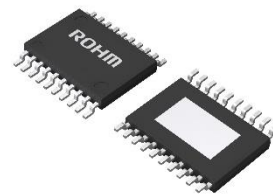

Typical Application Circuit

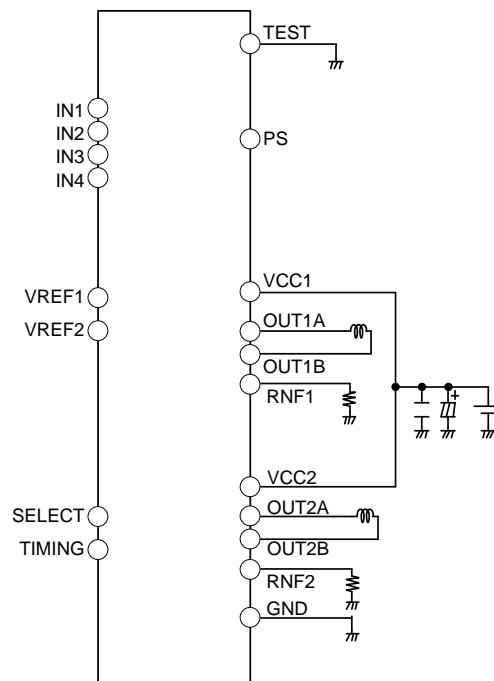

○Product structure : Silicon integrated circuit ○This product has no designed protection against radioactive rays

Pin Configuration

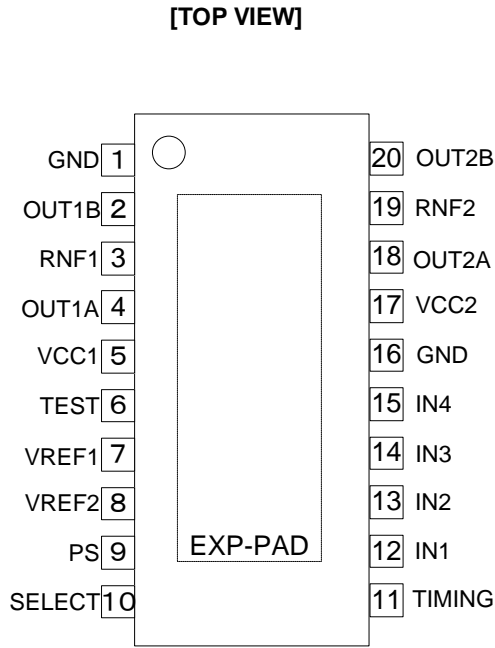

Block Diagram

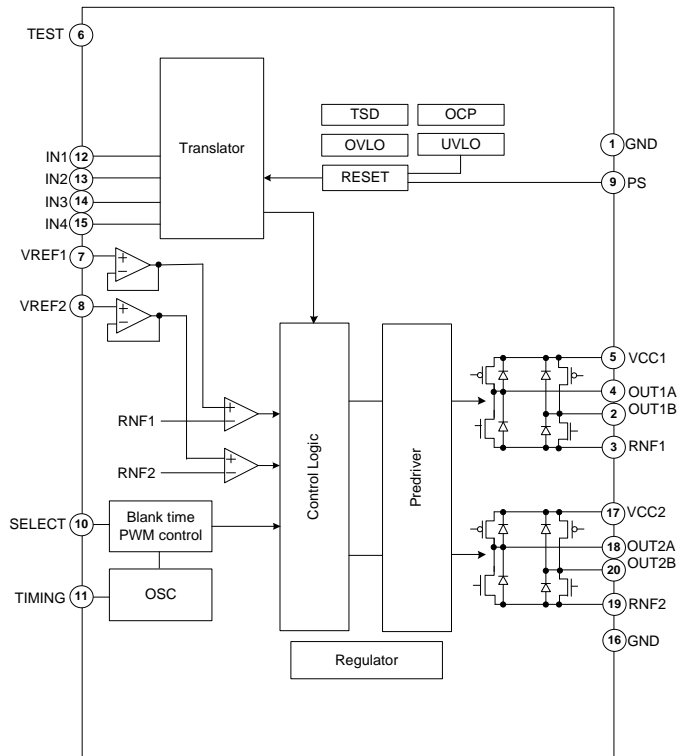

Pin Description

Pin No.	Pin Name	Function	Pin No.	Pin Name	Function
1	GND	Ground pin	11	TIMING	Chopping input pin
2	OUT1B	H bridge output pin	12	IN1	Phase selection pin
3	RNF1	Connection pin of resistor for output current detection	13	IN2	Phase selection pin
4	OUT1A	H bridge output pin	14	IN3	Phase selection pin
5	VCC1	Power supply pin	15	IN4	Phase selection pin
6	TEST	Pin for testing. (Used by connecting with GND)	16	GND	Ground pin
7	VREF1	Output current value setting pin	17	VCC2	Power supply pin
8	VREF2	Output current value setting pin	18	OUT2A	H bridge output pin
9	PS	Power save pin	19	RNF2	Connection pin of resistor for output current detection
10	SELECT	Minimum on time setting pin	20	OUT2B	H bridge output pin
-	EXP-PAD	The EXP-PAD of the product connect to GND.	-	-	-

Function Explanation

PS/Power Save Pin

The PS pin can make circuit standby state and make motor output OPEN. When PS=L→H, be careful because there is a delay of 40 μs (Max) before it is returned from standby state to normal state and the motor output becomes ACTIVE.

PS	Status
L	Standby state
H	ACTIVE

IN1, IN2, IN3, IN4/Phase Selection Pin

This is the pin to decide output pin logic.

PS	Input		Output		Status
	IN1 IN3	IN2 IN4	OUT1A OUT2A	OUT1B OUT2B	
L	x ^(Note 1)	x ^(Note 1)	OPEN	OPEN	POWER SAVE (STANDBY)
H	L	L	OPEN	OPEN	STOP
H	H	L	H	L	FORWARD
H	L	H	L	H	REVERSE
H	H	H	OPEN	OPEN	STOP

(Note 1) x=Low or High

VCC1, VCC2/Power Supply Pin

Motor's drive current is flowing in it, so the wire is thick, short and has low impedance. Voltage VCC may have great fluctuation due to counter electromotive force of the motor, PWM switching noise etc. So arrange the bypass capacitor of about 100 μF to 470 μF as close to the pin as possible and adjust the voltage VCC is stable. Increase the capacity as needed especially, when a large current is used or those motors that have great back electromotive force are used.

In addition, for the purpose of reducing of power supply's impedance in wideband, it is recommended to set parallel connection of multi-layered ceramic capacitor of 0.01 μF to 0.1 μF etc. Extreme care must be used to make sure that the voltage VCC does not exceed the rating even for a moment. VCC1 and VCC2 are shorted inside IC, but be sure to short externally VCC1 and VCC2 when using. If used without shorting, malfunction or destruction may occur because of concentration of current routes etc. Still more, in the power supply pin, there is built-in clamp component for preventing of electrostatic destruction. When a steep pulse signal or voltage such as a surge exceeding the absolute maximum rating is applied, this clamp component operates, as a result there is the danger of destruction, so be sure that the absolute maximum rating must not be exceeded. It is effective to mount a Zener diode of about the absolute maximum rating. Moreover, the diode for preventing of electrostatic destruction is inserted between the VCC1, VCC2 and GND pin, as a result there is the danger of IC destruction if reverse voltage is applied between the VCC1, VCC2 and GND pin, so be careful.

GND/Ground Pin

In order to reduce the noise caused by switching current and to stabilize the internal reference voltage of IC, the wiring impedance from this pin is made as low as possible to achieve the lowest electrical potential no matter what operating state it can be. Moreover, design patterns not to have any common impedance with other GND patterns.

OUT1A, OUT1B, OUT2A, OUT2B/H Bridge Output Pin

Motor's drive current is flowing in it, so the wire is thick, short and has low impedance. It is also effective to add a Schottky diode if output has positive or negative great fluctuation when large current, for example, counter electromotive voltage etc., is used. Moreover, in the output pin, there is built-in clamp component for preventing of electrostatic destruction. When a steep pulse signal or voltage such as a surge exceeding the absolute maximum rating is applied, this clamp component operates, as a result there is the danger of even destruction, so be sure that the absolute maximum rating must not be exceeded.

RNF_x^(Note 2)/Connection Pin Of Resistor For Detecting Of Output Current

Connect the resistor of 0.1 Ω to 0.7 Ω for current detection between this pin and GND. Determine the resistor so that power consumption $W=I_{OUT}^2 \times R$ [W] of the current-detecting resistor does not exceed rated power consumption. In addition, it has a low impedance and does not have a common impedance with other GND patterns because motor's drive current flows in the pattern through the RNF_x Pin to current-detecting resistor to GND. Do not exceed the rating because there is the possibility of circuits' malfunction etc., if the RNF_x voltage has exceeded the maximum rating (0.7 V). Moreover, be careful because if the RNF_x pin is shorted to GND, large current flows without normal PWM constant current control, then there is the danger that OCP or TSD will operate. If the RNF_x pin is open, then there is the possibility of such malfunction as output current does not flow either, so do not let it open.

(Note 2) x=1 or 2

Function Explanation – continued

VREF_x^(Note 1)/Output current value setting Pin

This is the pin to set the output current value. It can be set by VREF_x voltage and current-detecting resistor (RNF_x^(Note 1) resistor).
(Note 1) x=1 or 2

$$I_{OUT} = VREF_x / RNF_x \text{ [A]}$$

Where:

- I_{OUT}* is the output current.
- VREF_x* is the voltage of output current value-setting pin.
- RNF_x* is the current-detecting resistor.

Avoid using it with the VREF_x pin open because if the VREF_x pin is open, the input is unsettled, and the VREF_x voltage increases, and then there is the possibility of such malfunctions as the setting current increases and a large current flows etc. Keep to the input voltage range because if the voltage of 3 V or more is applied on the VREF_x pin, then there is also the danger that a large current flows in the output and so OCP or TSD will operate. Besides, select the resistance value in consideration of the outflow current (Max 2 μA) if it is inputted by resistance division. The minimum current, which can be controlled by VREF_x voltage, is determined by motor coil's L, R values and minimum ON time because there is a minimum ON time in PWM drive.

SELECT/ Minimum on time setting Pin

This is the pin to set the minimum on time.

SELECT	Minimum on time
L	1.55 μs (Typ)
H	2.50 μs (Typ)

TIMING/ Chopping input pin

This is the pin to set the chopping frequency of output. Output turn on again from current decay mode by changing this pin to the high voltage from the low voltage. Recommended frequency is from 20 kHz to 150 kHz.

Protection Circuits

Thermal Shutdown (TSD)

This IC has a built-in thermal shutdown circuit for thermal protection. When the IC's chip temperature rises 175 °C (Typ) or more, the motor output becomes OPEN. Also, when the temperature returns to 150 °C (Typ) or less, it automatically returns to normal operation. However, even when TSD is in operation, if heat is continued to be added externally, heat overdrive can lead to destruction.

Over Current Protection (OCP)

This IC has a built-in over current protection circuit as a provision against destruction when the motor outputs are shorted each other or VCC-motor output or motor output-GND is shorted. This circuit latches the motor output to OPEN condition when the regulated current flows for 4 μs (Typ). It returns with power reactivation or a reset by the PS pin. The over current protection circuit's only aim is to prevent the destruction of the IC from irregular situations such as motor output shorts, and is not meant to be used as protection or security for the set. Therefore, sets should not be designed to take into account this circuit's functions. After OCP operating, if irregular situations continue and the return by power reactivation or a reset by the PS pin, then OCP operates repeatedly and the IC may generate heat or otherwise deteriorate. When the L value of the wiring is great due to the wiring being long, the motor outputs are shorted each other or VCC-motor output or motor output-GND is shorted, if the output pin voltage jumps up and the absolute maximum values can be exceeded after the over current has flowed, there is a possibility of destruction. Also, when current which is the output current rating or more and the OCP detection current or less flows, the IC can heat up to $T_{jmax}=150$ °C exceeds and can deteriorate, so current which or more the output rating should not be applied.

Under Voltage Lock Out (UVLO)

This IC has a built-in under voltage lock out function to prevent false operation such as IC output during power supply under voltage is low. When the applied voltage to the VCC pin goes 5 V (Typ) or less, the motor output is set to OPEN. This switching voltage has a 1 V (Typ) hysteresis to prevent false operation by noise etc. Be aware that this circuit does not operate during power save mode.

Over Voltage Lock Out (OVLO)

This IC has a built-in over voltage lock out function to protect the IC output and the motor during power supply over voltage. When the applied voltage to the VCC pin goes 37 V (Typ) or more, the motor output is set to OPEN. This switching voltage has a 1 V (Typ) hysteresis and a 4 μs (Typ) mask time to prevent false operation by noise etc. Although this over voltage locked out circuit is built-in, there is a possibility of destruction if the absolute maximum value for power supply voltage is exceeded. Therefore, the absolute maximum value should not be exceeded. Be aware that this circuit does not operate during power save mode.

Protects against malfunction when power supply is disconnected (Ghost Supply Prevention Function)

If a signal (logic input and $VREF_x$ ^(Note 1)) is input when there is no power supplied to this IC, there is a function which prevents a malfunction where voltage is supplied to power supply of this IC or other IC in the set via the electrostatic destruction prevention diode from these input pins to the VCC. Therefore, there is no malfunction of the circuit even when voltage is supplied to these input pins while there is no power supply.

(Note 1) x=1 or 2

Operation Under Strong Electromagnetic Field

The IC is not designed for using in the presence of strong electromagnetic field. Be sure to confirm that no malfunction is found when using the IC in a strong electromagnetic field.

Absolute Maximum Rating (Ta=25 °C)

Item	Symbol	Rated Value	Unit
Supply Voltage	V _{CC1} , V _{CC2}	-0.2 to +40.0	V
Input Voltage for Control Pin	V _{IN}	-0.2 to +5.5	V
RNF _x ^(Note 1) Maximum Voltage	V _{RNF}	0.7	V
Output Current	I _{OUT}	1.35 ^(Note 2)	A/Phase
Storage Temperature	T _{stg}	-55 to +150	°C
Maximum Junction Temperature	T _{jmax}	+150	°C

(Note 1) x=1 or 2

(Note 2) Do not exceed T_{jmax}=150 °C.

Caution 1: Operating the IC over the absolute maximum ratings may damage the IC. The damage can either be a short circuit between pins or an open circuit between pins and the internal circuitry. Therefore, it is important to consider circuit protection measures, such as adding a fuse, in case the IC is operated over the absolute maximum ratings.

Caution 2: Should by any chance the maximum junction temperature rating be exceeded the rise in temperature of the chip may result in deterioration of the properties of the chip. In case of exceeding this absolute maximum rating, design a PCB with thermal resistance taken into consideration by increasing board size and copper area so as not to exceed the maximum junction temperature rating.

Recommended Operating Condition

Item	Symbol	Min	Typ	Max	Unit
Supply Voltage	V _{CC1} , V _{CC2}	8	30	33	V
Operating Temperature	T _{opr}	-25	+25	+85	°C
Maximum Output Current (DC)	I _{OUT}	-	-	1.1 ^(Note 3)	A/Phase

(Note 3) Do not exceed T_{jmax}=150 °C.

Thermal Resistance^(Note 4)

Parameter	Symbol	Thermal Resistance (Typ)		Unit
		1s ^(Note 6)	2s2p ^(Note 7)	
HTSSOP-B20				
Junction to Ambient	θ _{JA}	95.5	26.8	°C/W
Junction to Top Characterization Parameter ^(Note 5)	Ψ _{JT}	8	4	°C/W

(Note 4) Based on JESD51-2A(Still-Air), using a BD63401EFV Chip.

(Note 5) The thermal characterization parameter to report the difference between junction temperature and the temperature at the top center of the outside surface of the component package.

(Note 6) Using a PCB board based on JESD51-3.

(Note 7) Using a PCB board based on JESD51-5, 7.

Layer Number of Measurement Board	Material	Board Size
Single	FR-4	114.3 mm x 76.2 mm x 1.57 mmt
Top		
Copper Pattern	Thickness	
Footprints and Traces	70 μm	

Layer Number of Measurement Board	Material	Board Size	Thermal Via ^(Note 8)		
			Pitch	Diameter	
4 Layers	FR-4	114.3 mm x 76.2 mm x 1.6 mmt	1.20 mm	Φ0.30 mm	
Top		2 Internal Layers		Bottom	
Copper Pattern	Thickness	Copper Pattern	Thickness	Copper Pattern	Thickness
Footprints and Traces	70 μm	74.2 mm x 74.2 mm	35 μm	74.2 mm x 74.2 mm	70 μm

(Note 8) This thermal via connects with the copper pattern of all layers.

Electrical Characteristics (Unless otherwise specified Ta=25 °C, V_{CC1}=V_{CC2}=30 V)

Item	Symbol	Specification			Unit	Condition
		Min	Typ	Max		
[Whole]						
Circuit Current at Standby	I _{CCST}	-	-	10	μA	PS=L
Circuit Current	I _{CC}	-	2.0	5.0	mA	PS=H, VREF1=VREF2=3 V
[Control input]						
H-level Input Voltage	V _{INH}	2.0	-	-	V	
L-level Input Voltage	V _{INL}	-	-	0.8	V	
H-level Input Current	I _{INH}	35	50	100	μA	V _{IN} =5 V
L-level Input Current	I _{INL}	-10	0	-	μA	V _{IN} =0 V
[Output (OUT1A, OUT1B, OUT2A, OUT2B)]						
Output ON Resistance	R _{ON}	-	1.0	1.4	Ω	I _{OUT} = ±1.1 A (Sum of upper and lower)
Output Leak Current	I _{LEAK}	-	-	10	μA	
[Current control]						
RNF _x ^(Note 1) Input Current	I _{RNF}	-80	-40	-	μA	RNF _x =0 V
VREF _x ^(Note 1) Input Current	I _{VREF}	-2.0	-0.1	-	μA	VREF _x =0 V
VREF _x ^(Note 1) Input Voltage Range	V _{VREF}	0	-	3.0	V	
Minimum ON Time1 (Blank time)	t _{ONMIN1}	0.70	1.55	3.10	μs	SELECT=L
Minimum ON Time2 (Blank time)	t _{ONMIN2}	1.25	2.50	4.50	μs	SELECT=H
Comparator Threshold	V _{CTH}	0.579	0.600	0.621	V	VREF _x =0.6 V

(Note 1) x=1 or 2

PWM Constant Current Control

1 Current control operation

The output current increases due to the output transistor turned on. When the voltage on the $RNF_x^{(Note 1)}$ pin, the output current is converted it due to connect the external resistance to RNF_x pin, reaches the voltage value set by the $VREF_x$ pin input voltage, the current limit comparator operates and enters current decay mode. Output turn on after changing this pin to the high voltage from the low voltage. The process repeats itself with chopping period (t_{CHOP}).

(Note 1) $x=1$ or 2

2 Noise-masking function

In order to avoid misdetection of current detection comparator due to RNF spike noise that may occur when the output turns ON, the IC has the minimum ON time (t_{ONMIN}). The current detection is invalid from the output transistor turned on to t_{ONMIN} . This allows for constant-current drive without the need for an external filter.

3 PWM Timing Chart

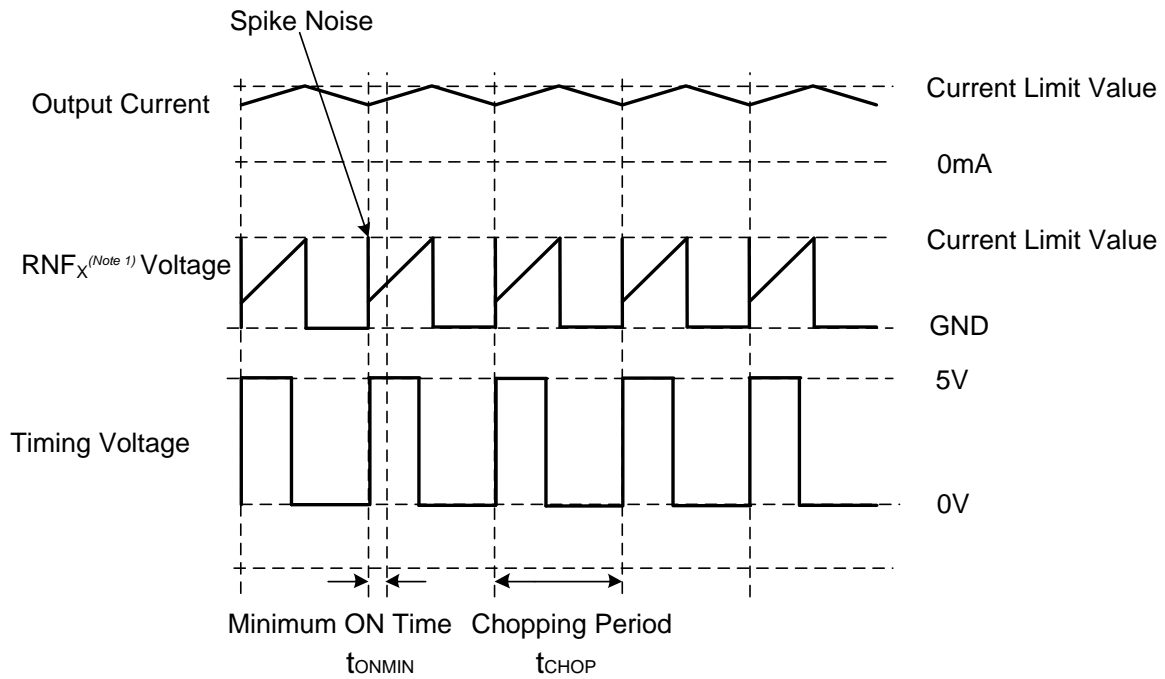

(Note 1) $x=1$ or 2

Figure 1. Timing chart of TIMING voltage, RNF_x voltage and output current

PWM Constant Current Control – continued

Current Decay Mode

In PWM constant current control, SLOW DECAY in synchronous rectification mode is adopted to minimize IC power consumption. The diagram shows the operating state of each transistor and the regenerative current path during attenuation at SLOW DECAY.

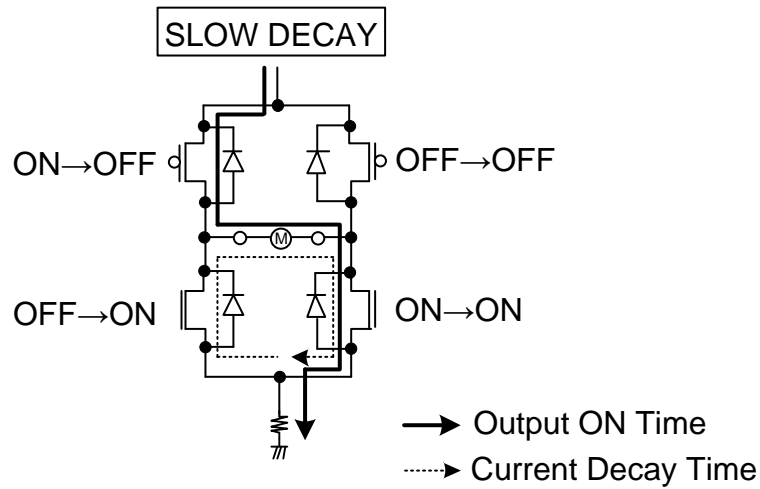

Figure 2. Route of Regenerated Current during Current Decay

About the merits of SLOW DECAY, the voltage of motor coils is small and the regenerative current decreases slowly. So the output current ripple is small and it is advantageous for motor torque. However, output current increasing according to fall-off current characteristic deterioration in the low-current area and it is easily influenced by EMF when pulse late is high. As a result, the waveform is distortion and motor oscillation increasing in the half-step mode. Thus, this decay mode is most suited to full-step mode or low-pulse-rate as half-step mode.

PARA-IN Drive Mode

It is possible to drive stepping motor with FULL STEP, HALF STEP, by inputting the following motor control signals using PARA-IN drive mode.

Examples of control sequence and torque vector

FULL STEP

Controlled by logic signals of IN1, IN2, IN3, IN4

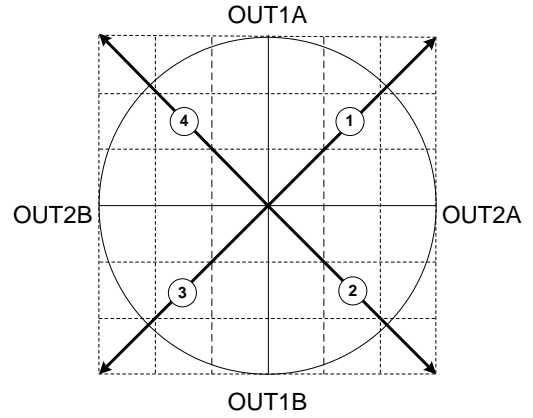
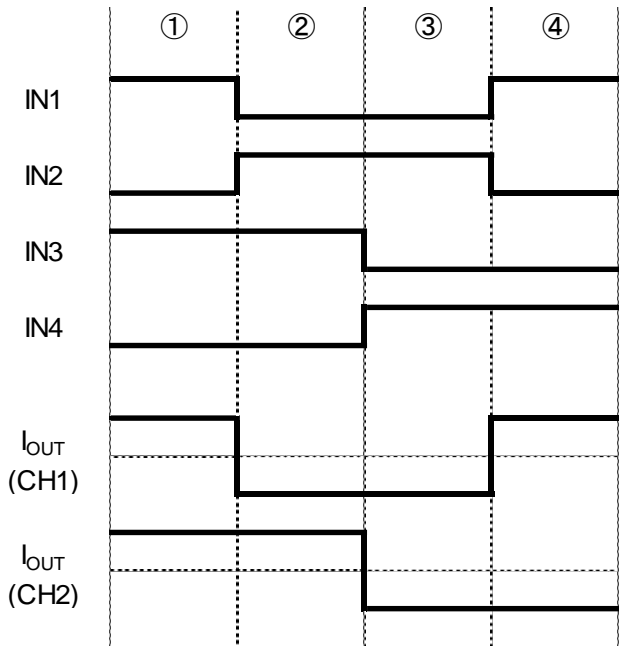

HALF STEP

Controlled by logic signals of IN1, IN2, IN3, IN4

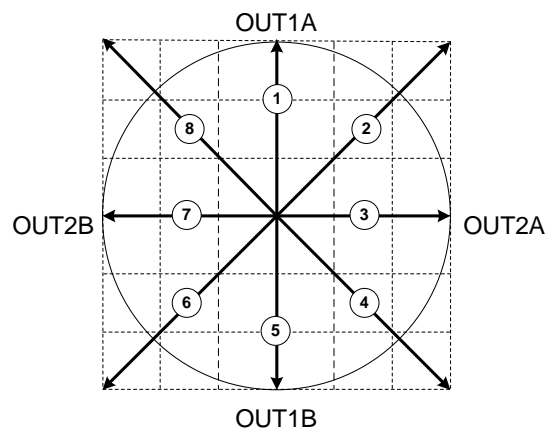
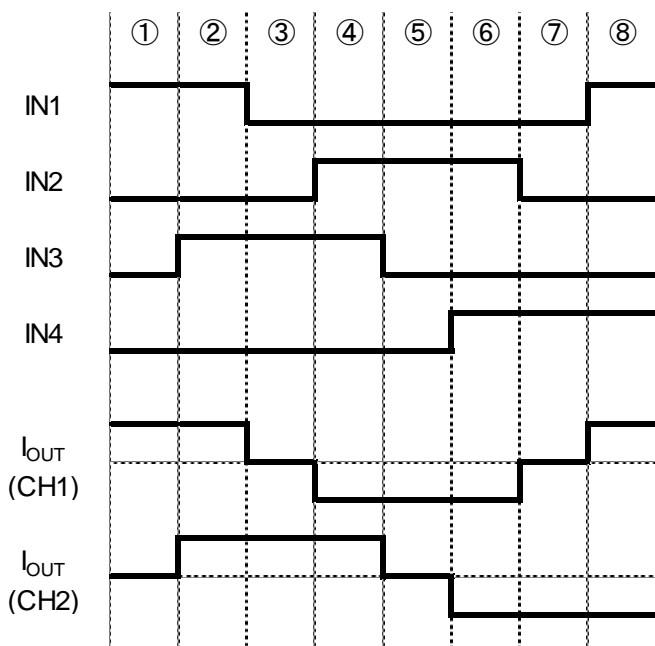

Power Dissipation

Confirm that the IC's chip temperature T_j is not over 150 °C in consideration of the IC's power consumption (W), thermal resistance (°C/W) and ambient temperature (T_a). When $T_j=150$ °C is exceeded, the functions as a semiconductor do not operate and problems such as parasitism and leaks occur. Constant use under these circumstances leads to deterioration and eventually destruction of the IC. $T_{jmax}=150$ °C must be strictly obeyed under all circumstances.

Thermal Calculation

The IC's consumed power can be estimated roughly with the power supply voltage (V_{CC}), circuit current (I_{CC}), output ON resistance (R_{ONH} , R_{ONL}) and motor output current value (I_{OUT}).

The calculation method during FULL STEP drive, SLOW DECAY mode is shown here:

$$W_{VCC} = V_{CC} \times I_{CC} \quad [W]$$

where:

- W_{VCC} is the consumed power of the V_{CC} .
- V_{CC} is the power supply voltage.
- I_{CC} is the circuit current.

$$W_{DMOS} = W_{ON} + W_{DECAY} \quad [W]$$

$$W_{ON} = (R_{ONH} + R_{ONL}) \times I_{OUT}^2 \times 2 \times on_duty \quad [W]$$

$$W_{DECAY} = (2 \times R_{ONL}) \times I_{OUT}^2 \times 2 \times (1 - on_duty) \quad [W]$$

where:

- W_{DMOS} is the consumed power of the output DMOS.
- W_{ON} is the consumed power during output ON.
- W_{DECAY} is the consumed power during current decay.
- R_{ONH} is the upper P-channel DMOS ON-resistance.
- R_{ONL} is the lower N-channel DMOS ON-resistance.
- I_{OUT} is the motor output current value.
- on_duty PWM on duty
 $= t_{ON} / t_{CHOP}$
- "2" is the H bridge 1 and 2.

t_{ON} varies depending on the L and R values of the motor coil and the current set value. Confirm by actual measurement, or make an approximate calculation.

t_{CHOP} is the chopping period, which depends on the TIMING pin. Refer to [P.8](#) for details.

IC number	Upper Pch DMOS ON Resistance $R_{ONH}[\Omega]$ (Typ)	Lower Nch DMOS ON Resistance $R_{ONL}[\Omega]$ (Typ)
BD63401EFV	0.60	0.40

$$W_{total} = W_{VCC} + W_{DMOS} \quad [W]$$

$$T_j = T_a + \theta_{ja} \times W_{total} \quad [^{\circ}C]$$

where:

- W_{total} is the consumed total power of IC.
- T_j is the junction temperature.
- T_a is the ambient temperature.
- θ_{ja} is the thermal resistance value.

However, the thermal resistance value θ_{ja} [°C/W] differs greatly depending on circuit board conditions. The calculated values above are only theoretical. For actual thermal design, perform sufficient thermal evaluation for the application board used, and create the thermal design with enough margin not to exceed $T_{jmax}=150$ °C. Although unnecessary with normal use, if the IC is used under especially strict heat conditions, consider externally attaching a Schottky diode between the motor output pin and GND to abate heat from the IC.

Power Dissipation - continued

Temperature Monitoring

In respect of BD63401EFV, there is a way to directly measure the approximate chip temperature by using the TEST pin with a protection diode for prevention from electrostatic discharge. However, temperature monitor way is used only for evaluation and experimenting, and must not be used in actual usage conditions.

- (1) Measure the pin voltage when a current of $I_{DIODE}=50 \mu A$ flows from the monitor TEST pin to the GND, without supplying VCC to the IC. This measurement is for measuring the V_F voltage of the internal diode.
- (2) Measure the temperature characteristics of this pin voltage. (V_F has a linear negative temperature factor against the temperature.) With the results of these temperature characteristics, chip temperature can be calibrated from the TEST pin voltage.
- (3) Supply VCC, confirm the TEST pin voltage while running the motor, and the chip temperature can be approximated from the results of (2).

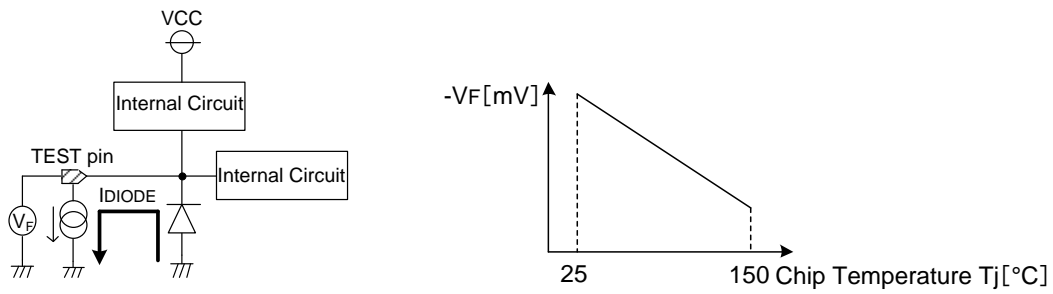
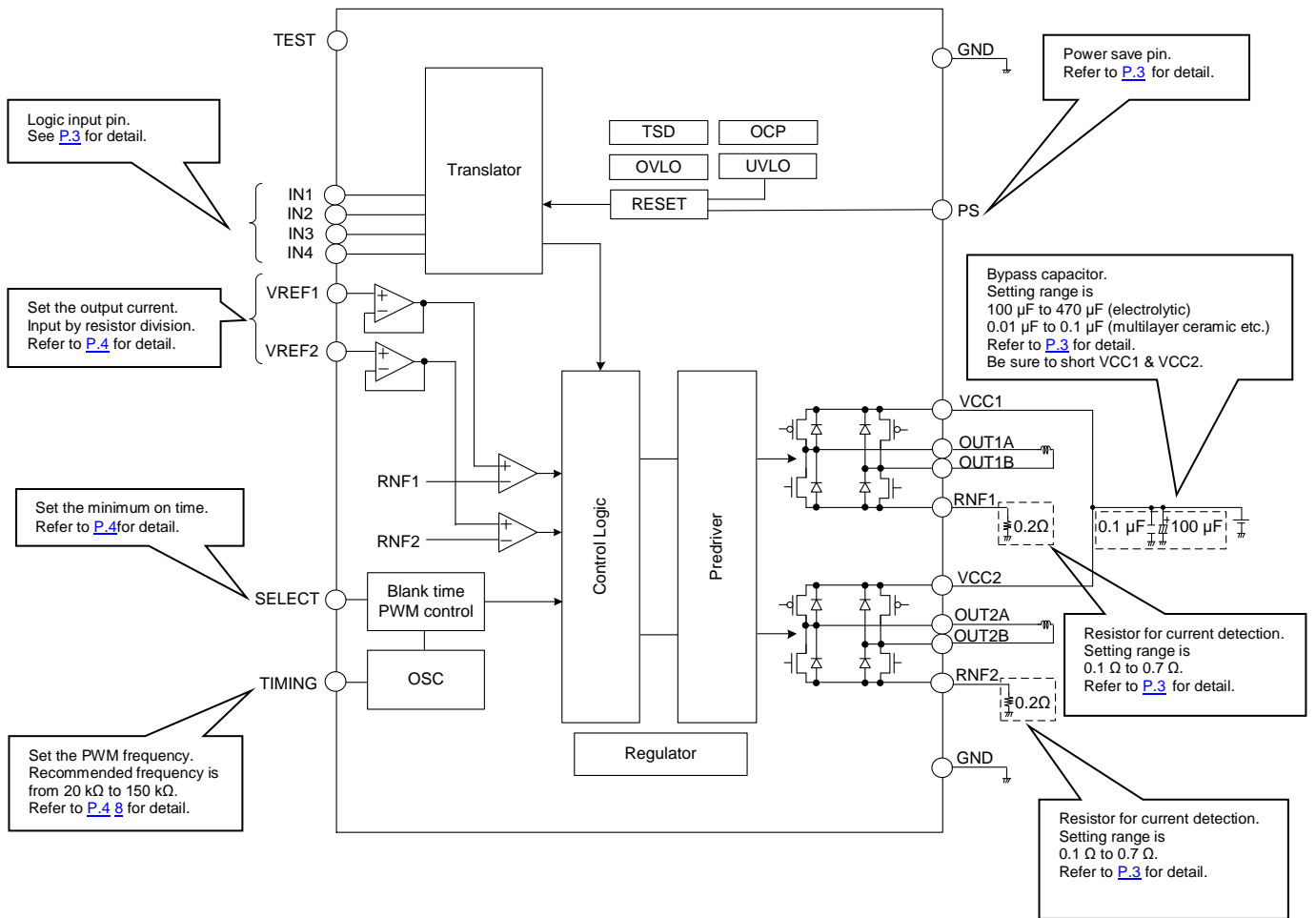
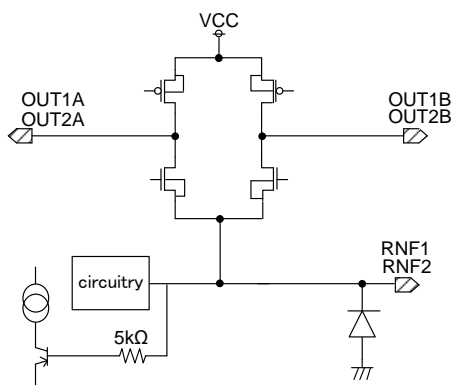
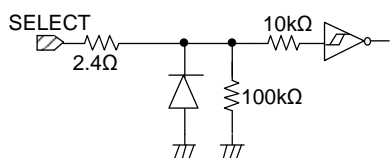
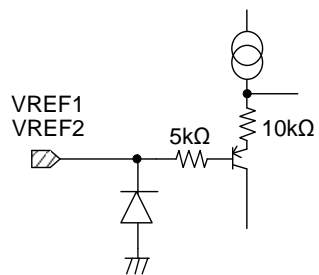
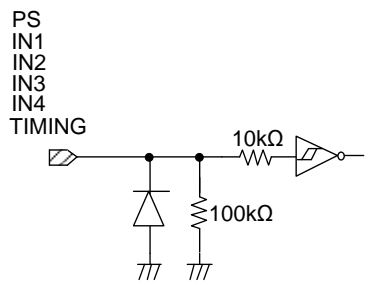

Figure 3. Model diagram for measuring chip temperature

Application Example



I/O Equivalence Circuit



Operational Notes

1. Reverse Connection of Power Supply

Connecting the power supply in reverse polarity can damage the IC. Take precautions against reverse polarity when connecting the power supply, such as mounting an external diode between the power supply and the IC's power supply pins.

2. Power Supply Lines

Design the PCB layout pattern to provide low impedance supply lines. Furthermore, connect a capacitor to ground at all power supply pins. Consider the effect of temperature and aging on the capacitance value when using electrolytic capacitors.

3. Ground Voltage

Ensure that no pins are at a voltage below that of the ground pin at any time, even during transient condition.

4. Ground Wiring Pattern

When using both small-signal and large-current ground traces, the two ground traces should be routed separately but connected to a single ground at the reference point of the application board to avoid fluctuations in the small-signal ground caused by large currents. Also ensure that the ground traces of external components do not cause variations on the ground voltage. The ground lines must be as short and thick as possible to reduce line impedance.

5. Recommended Operating Conditions

The function and operation of the IC are guaranteed within the range specified by the recommended operating conditions. The characteristic values are guaranteed only under the conditions of each item specified by the electrical characteristics.

6. Inrush Current

When power is first supplied to the IC, it is possible that the internal logic may be unstable and inrush current may flow instantaneously due to the internal powering sequence and delays, especially if the IC has more than one power supply. Therefore, give special consideration to power coupling capacitance, power wiring, width of ground wiring, and routing of connections.

7. Testing on Application Boards

When testing the IC on an application board, connecting a capacitor directly to a low-impedance output pin may subject the IC to stress. Always discharge capacitors completely after each process or step. The IC's power supply should always be turned off completely before connecting or removing it from the test setup during the inspection process. To prevent damage from static discharge, ground the IC during assembly and use similar precautions during transport and storage.

8. Inter-pin Short and Mounting Errors

Ensure that the direction and position are correct when mounting the IC on the PCB. Incorrect mounting may result in damaging the IC. Avoid nearby pins being shorted to each other especially to ground, power supply and output pin. Inter-pin shorts could be due to many reasons such as metal particles, water droplets (in very humid environment) and unintentional solder bridge deposited in between pins during assembly to name a few.

9. Unused Input Pins

Input pins of an IC are often connected to the gate of a MOS transistor. The gate has extremely high impedance and extremely low capacitance. If left unconnected, the electric field from the outside can easily charge it. The small charge acquired in this way is enough to produce a significant effect on the conduction through the transistor and cause unexpected operation of the IC. So unless otherwise specified, unused input pins should be connected to the power supply or ground line.

Operational Notes – continued

10. Regarding the Input Pin of the IC

This monolithic IC contains P+ isolation and P substrate layers between adjacent elements in order to keep them isolated. P-N junctions are formed at the intersection of the P layers with the N layers of other elements, creating a parasitic diode or transistor. For example (refer to figure below):

When $GND > Pin A$ and $GND > Pin B$, the P-N junction operates as a parasitic diode.
 When $GND > Pin B$, the P-N junction operates as a parasitic transistor.

Parasitic diodes inevitably occur in the structure of the IC. The operation of parasitic diodes can result in mutual interference among circuits, operational faults, or physical damage. Therefore, conditions that cause these diodes to operate, such as applying a voltage lower than the GND voltage to an input pin (and thus to the P substrate) should be avoided.

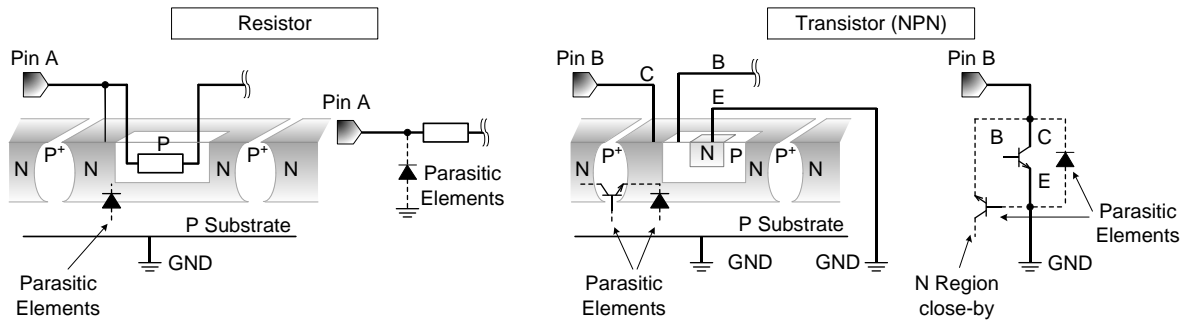

Figure 9. Example of monolithic IC structure

11. Ceramic Capacitor

When using a ceramic capacitor, determine a capacitance value considering the change of capacitance with temperature and the decrease in nominal capacitance due to DC bias and others.

12. Thermal Shutdown Circuit(TSD)

This IC has a built-in thermal shutdown circuit that prevents heat damage to the IC. Normal operation should always be within the IC's maximum junction temperature rating. If however the rating is exceeded for a continued period, the junction temperature (T_j) will rise which will activate the TSD circuit that will turn OFF power output pins. When the T_j falls below the TSD threshold, the circuits are automatically restored to normal operation.

Note that the TSD circuit operates in a situation that exceeds the absolute maximum ratings and therefore, under no circumstances, should the TSD circuit be used in a set design or for any purpose other than protecting the IC from heat damage.

13. Over Current Protection Circuit (OCP)

This IC incorporates an integrated overcurrent protection circuit that is activated when the load is shorted. This protection circuit is effective in preventing damage due to sudden and unexpected incidents. However, the IC should not be used in applications characterized by continuous operation or transitioning of the protection circuit.

Ordering Information

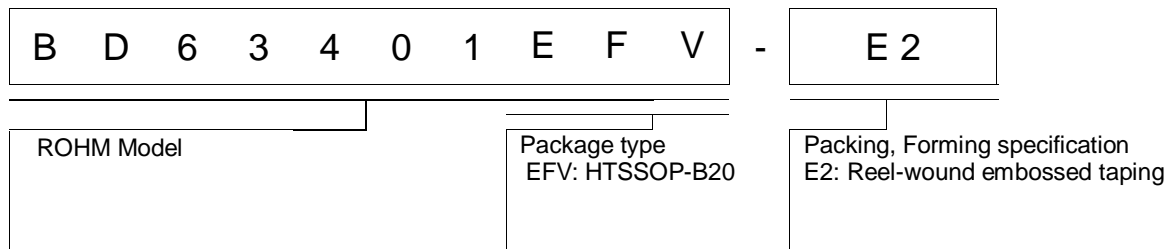

Marking Diagram

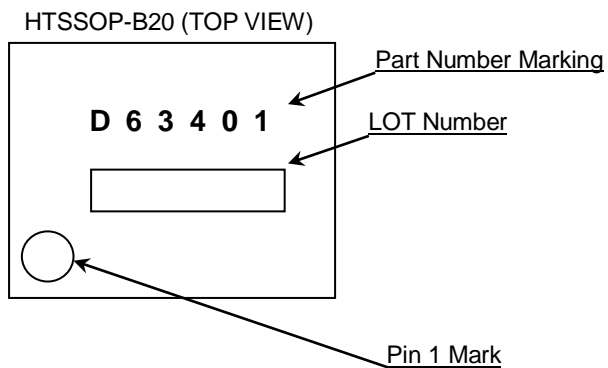

Physical Dimension and Packing Information

Package Name	HTSSOP-B20
--------------	------------

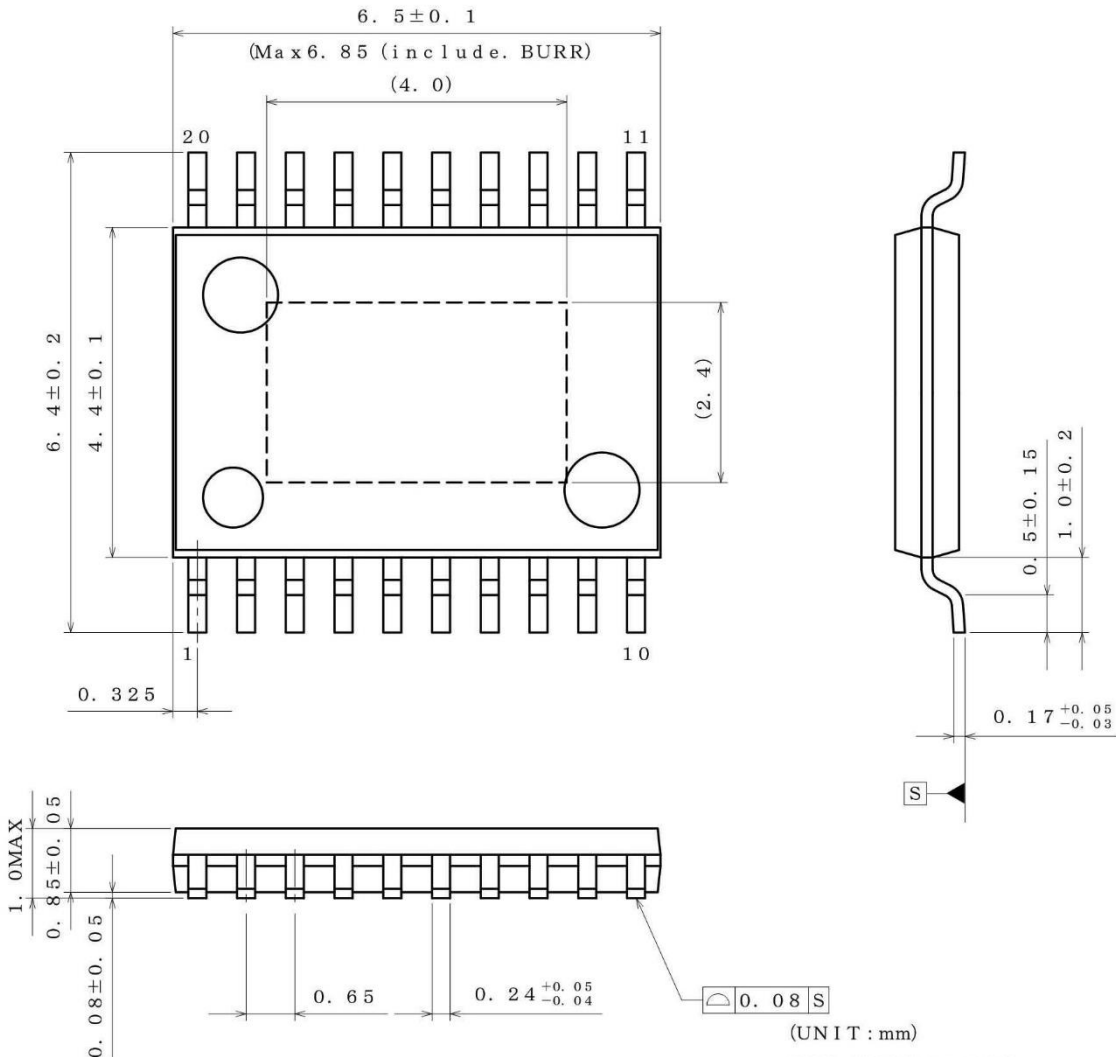

(UNIT : mm)
 PKG : HTSSOP-B20
 Drawing No. EX192-5002

<Tape and Reel information>

Tape	Embossed carrier tape (with dry pack)
Quantity	2500pcs
Direction of feed	E2 (The direction is the 1pin of product is at the upper left when you hold reel on the left hand and you pull out the tape on the right hand)

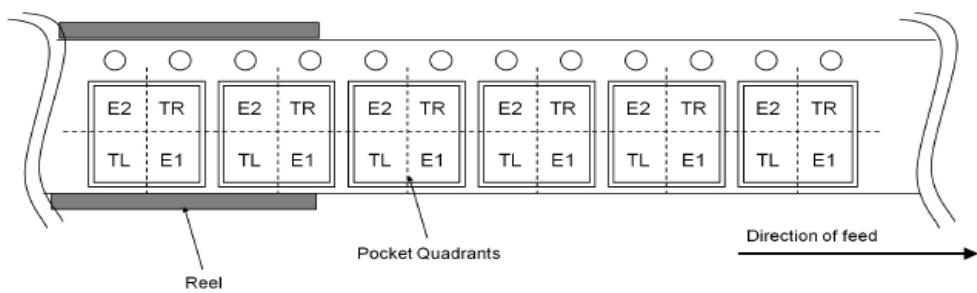

Revision History

Date	Revision	Changes
26.Oct.2018	001	New Release

Notice

Precaution on using ROHM Products

- Our Products are designed and manufactured for application in ordinary electronic equipment (such as AV equipment, OA equipment, telecommunication equipment, home electronic appliances, amusement equipment, etc.). If you intend to use our Products in devices requiring extremely high reliability (such as medical equipment ^(Note 1), transport equipment, traffic equipment, aircraft/spacecraft, nuclear power controllers, fuel controllers, car equipment including car accessories, safety devices, etc.) and whose malfunction or failure may cause loss of human life, bodily injury or serious damage to property ("Specific Applications"), please consult with the ROHM sales representative in advance. Unless otherwise agreed in writing by ROHM in advance, ROHM shall not be in any way responsible or liable for any damages, expenses or losses incurred by you or third parties arising from the use of any ROHM's Products for Specific Applications.

(Note1) Medical Equipment Classification of the Specific Applications

JAPAN	USA	EU	CHINA
CLASS III	CLASS III	CLASS II b	CLASS III
CLASS IV		CLASS III	

- ROHM designs and manufactures its Products subject to strict quality control system. However, semiconductor products can fail or malfunction at a certain rate. Please be sure to implement, at your own responsibilities, adequate safety measures including but not limited to fail-safe design against the physical injury, damage to any property, which a failure or malfunction of our Products may cause. The following are examples of safety measures:
 - Installation of protection circuits or other protective devices to improve system safety
 - Installation of redundant circuits to reduce the impact of single or multiple circuit failure
- Our Products are designed and manufactured for use under standard conditions and not under any special or extraordinary environments or conditions, as exemplified below. Accordingly, ROHM shall not be in any way responsible or liable for any damages, expenses or losses arising from the use of any ROHM's Products under any special or extraordinary environments or conditions. If you intend to use our Products under any special or extraordinary environments or conditions (as exemplified below), your independent verification and confirmation of product performance, reliability, etc. prior to use, must be necessary:
 - Use of our Products in any types of liquid, including water, oils, chemicals, and organic solvents
 - Use of our Products outdoors or in places where the Products are exposed to direct sunlight or dust
 - Use of our Products in places where the Products are exposed to sea wind or corrosive gases, including Cl₂, H₂S, NH₃, SO₂, and NO₂
 - Use of our Products in places where the Products are exposed to static electricity or electromagnetic waves
 - Use of our Products in proximity to heat-producing components, plastic cords, or other flammable items
 - Sealing or coating our Products with resin or other coating materials
 - Use of our Products without cleaning residue of flux (Exclude cases where no-clean type fluxes is used. However, recommend sufficiently about the residue.) ; or Washing our Products by using water or water-soluble cleaning agents for cleaning residue after soldering
 - Use of the Products in places subject to dew condensation
- The Products are not subject to radiation-proof design.
- Please verify and confirm characteristics of the final or mounted products in using the Products.
- In particular, if a transient load (a large amount of load applied in a short period of time, such as pulse. is applied, confirmation of performance characteristics after on-board mounting is strongly recommended. Avoid applying power exceeding normal rated power; exceeding the power rating under steady-state loading condition may negatively affect product performance and reliability.
- De-rate Power Dissipation depending on ambient temperature. When used in sealed area, confirm that it is the use in the range that does not exceed the maximum junction temperature.
- Confirm that operation temperature is within the specified range described in the product specification.
- ROHM shall not be in any way responsible or liable for failure induced under deviant condition from what is defined in this document.

Precaution for Mounting / Circuit board design

- When a highly active halogenous (chlorine, bromine, etc.) flux is used, the residue of flux may negatively affect product performance and reliability.
- In principle, the reflow soldering method must be used on a surface-mount products, the flow soldering method must be used on a through hole mount products. If the flow soldering method is preferred on a surface-mount products, please consult with the ROHM representative in advance.

For details, please refer to ROHM Mounting specification

Precautions Regarding Application Examples and External Circuits

1. If change is made to the constant of an external circuit, please allow a sufficient margin considering variations of the characteristics of the Products and external components, including transient characteristics, as well as static characteristics.
2. You agree that application notes, reference designs, and associated data and information contained in this document are presented only as guidance for Products use. Therefore, in case you use such information, you are solely responsible for it and you must exercise your own independent verification and judgment in the use of such information contained in this document. ROHM shall not be in any way responsible or liable for any damages, expenses or losses incurred by you or third parties arising from the use of such information.

Precaution for Electrostatic

This Product is electrostatic sensitive product, which may be damaged due to electrostatic discharge. Please take proper caution in your manufacturing process and storage so that voltage exceeding the Products maximum rating will not be applied to Products. Please take special care under dry condition (e.g. Grounding of human body / equipment / solder iron, isolation from charged objects, setting of Ionizer, friction prevention and temperature / humidity control).

Precaution for Storage / Transportation

1. Product performance and soldered connections may deteriorate if the Products are stored in the places where:
 - [a] the Products are exposed to sea winds or corrosive gases, including Cl₂, H₂S, NH₃, SO₂, and NO₂
 - [b] the temperature or humidity exceeds those recommended by ROHM
 - [c] the Products are exposed to direct sunshine or condensation
 - [d] the Products are exposed to high Electrostatic
2. Even under ROHM recommended storage condition, solderability of products out of recommended storage time period may be degraded. It is strongly recommended to confirm solderability before using Products of which storage time is exceeding the recommended storage time period.
3. Store / transport cartons in the correct direction, which is indicated on a carton with a symbol. Otherwise bent leads may occur due to excessive stress applied when dropping of a carton.
4. Use Products within the specified time after opening a humidity barrier bag. Baking is required before using Products of which storage time is exceeding the recommended storage time period.

Precaution for Product Label

A two-dimensional barcode printed on ROHM Products label is for ROHM's internal use only.

Precaution for Disposition

When disposing Products please dispose them properly using an authorized industry waste company.

Precaution for Foreign Exchange and Foreign Trade act

Since concerned goods might be fallen under listed items of export control prescribed by Foreign exchange and Foreign trade act, please consult with ROHM in case of export.

Precaution Regarding Intellectual Property Rights

1. All information and data including but not limited to application example contained in this document is for reference only. ROHM does not warrant that foregoing information or data will not infringe any intellectual property rights or any other rights of any third party regarding such information or data.
2. ROHM shall not have any obligations where the claims, actions or demands arising from the combination of the Products with other articles such as components, circuits, systems or external equipment (including software).
3. No license, expressly or implied, is granted hereby under any intellectual property rights or other rights of ROHM or any third parties with respect to the Products or the information contained in this document. Provided, however, that ROHM will not assert its intellectual property rights or other rights against you or your customers to the extent necessary to manufacture or sell products containing the Products, subject to the terms and conditions herein.

Other Precaution

1. This document may not be reprinted or reproduced, in whole or in part, without prior written consent of ROHM.
2. The Products may not be disassembled, converted, modified, reproduced or otherwise changed without prior written consent of ROHM.
3. In no event shall you use in any way whatsoever the Products and the related technical information contained in the Products or this document for any military purposes, including but not limited to, the development of mass-destruction weapons.
4. The proper names of companies or products described in this document are trademarks or registered trademarks of ROHM, its affiliated companies or third parties.

General Precaution







1. Before you use our Products, you are requested to carefully read this document and fully understand its contents. ROHM shall not be in any way responsible or liable for failure, malfunction or accident arising from the use of any ROHM's Products against warning, caution or note contained in this document.
2. All information contained in this document is current as of the issuing date and subject to change without any prior notice. Before purchasing or using ROHM's Products, please confirm the latest information with a ROHM sales representative.
3. The information contained in this document is provided on an "as is" basis and ROHM does not warrant that all information contained in this document is accurate and/or error-free. ROHM shall not be in any way responsible or liable for any damages, expenses or losses incurred by you or third parties resulting from inaccuracy or errors of or concerning such information.

Looking for pricing, stock, or lifecycle information?

Click below to explore more details on WIN SOURCE:

-  [View BD63401EFV-E2 on WIN SOURCE](#)
-  [Rohm Semiconductor](#) Information

Optimize Your Supply Chain with WIN SOURCE Solutions

-  Global Sourcing Solution
-  Obsolete Management
-  Cost Control Management
-  Shortage Management
-  Alternative Solution
-  Excess Inventory Management