



**THE DATASHEET OF  
BD61243FV-GE2**



DC Brushless Fan Motor Drivers

# Multifunction Single-phase Full-wave Fan Motor Driver

## BD61243FV

### General Description

BD61243FV is a 1chip driver that is composed of H-bridge power DMOS FET. Moreover, the circuit configuration is restructured, and convenience has been improved by reducing the external parts and simplifying the setting compared with the conventional driver.

### Key Specifications

- Operating Voltage Range: 5.5V to 16V
- Operating Temperature Range: -40°C to +105°C
- Output Voltage(total): 0.2V(Typ) at 0.2A

### Features

- SSOP Small Package
- Driver Including Power DMOS FET
- Speed Controllable by DC / PWM Input
- I/O Duty Slope Adjust
- PWM Soft Switching
- Current Limit
- Start Duty Assist
- Lock Protection and Automatic Restart
- Quick Start
- Rotation Speed Pulse Signal (FG) Output

### Package

W (Typ) x D (Typ) x H (Max)  
5.00mm x 6.40mm x 1.35mm

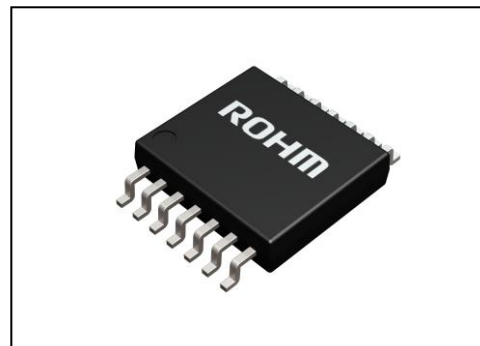

SSOP-B14

### Applications

- Fan motors for general consumer equipment of desktop PC, Projector, etc.

### Typical Application Circuits

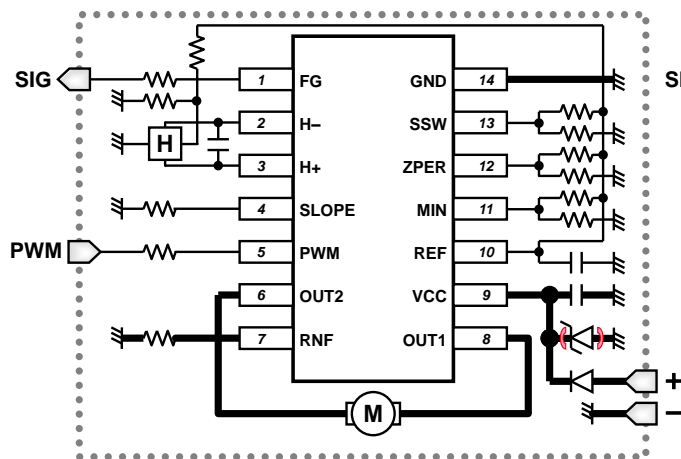

Figure 1. Application of Direct PWM Input

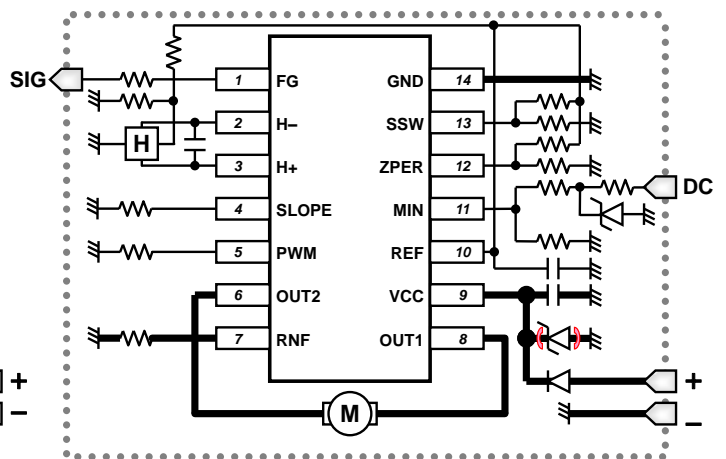
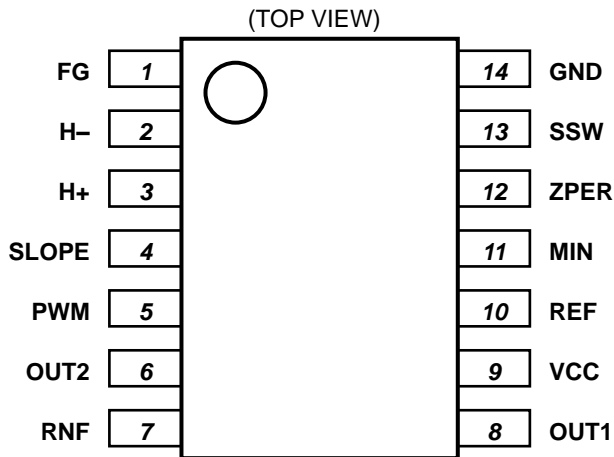
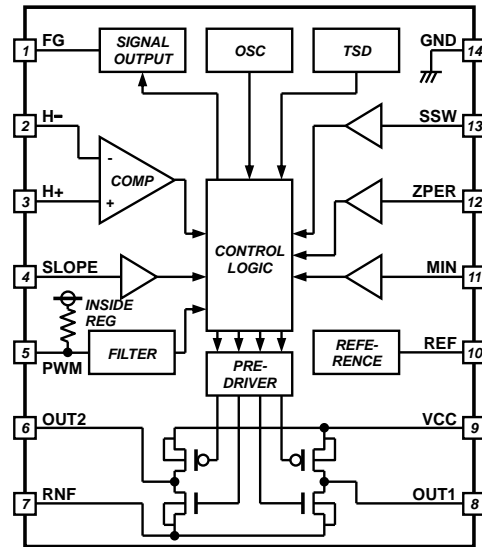

Figure 2. Application of DC Voltage Input

Pin Configuration



Block Diagram



Pin Description

P/No.	T/Name	Function
1	FG	Speed pulse signal output terminal
2	H-	Hall - input terminal
3	H+	Hall + input terminal
4	SLOPE	I/O duty slope setting terminal
5	PWM	PWM input duty terminal
6	OUT2	Motor output terminal 2
7	RNF	Output current detecting resistor connecting terminal (motor ground)
8	OUT1	Motor output terminal 1
9	VCC	Power supply terminal
10	REF	Reference voltage output terminal
11	MIN	Minimum output duty setting terminal
12	ZPER	Re-circulate period setting terminal
13	SSW	Soft switching setting terminal
14	GND	Ground terminal (signal ground)

I/O Truth Table

Hall Input		Driver Output		
H+	H-	OUT1	OUT2	FG
H	L	L	H	Hi-Z
L	H	H	L	L

H: High, L; Low, Hi-Z: High impedance  
 FG output is open-drain type.

**Absolute Maximum Ratings**

Parameter	Symbol	Rating	Unit
Supply Voltage	V <sub>CC</sub>	18	V
Power Dissipation	P <sub>d</sub>	0.87 (Note 1)	W
Operating Temperature Range	T <sub>opr</sub>	-40 to +105	°C
Storage Temperature Range	T <sub>stg</sub>	-55 to +150	°C
Output Voltage	V <sub>OMAX</sub>	18	V
Output Current	I <sub>OMAX</sub>	1.2 (Note 2)	A
Rotation Speed Pulse Signal (FG) Output Voltage	V <sub>FG</sub>	18	V
Rotation Speed Pulse Signal (FG) Output Current	I <sub>FG</sub>	10	mA
Reference Voltage (REF) Output Current	I <sub>REF</sub>	10	mA
Input Voltage1 (H+, H-, MIN, SSW, ZPER, SLOPE)	V <sub>IN1</sub>	4	V
Input Voltage2 (PWM)	V <sub>IN2</sub>	6.5	V
Junction Temperature	T <sub>j</sub>	150	°C

(Note 1) Derate by 7.0mW/°C when operating over Ta=25°C. (Mounted on 70.0mmx70.0mmx1.6mm glass epoxy board)

(Note 2) Do not exceed P<sub>d</sub> and T<sub>j</sub>=150°C.

**Caution:** Operating the IC over the absolute maximum ratings may damage the IC. The damage can either be a short circuit between pins or an open circuit between pins and the internal circuitry. Therefore, it is important to consider circuit protection measures, such as adding a fuse, in case the IC is operated over the absolute maximum ratings.

**Recommended Operating Conditions**

Parameter	Symbol	Min	Typ	Max	Unit
Operating Supply Voltage Range	V <sub>CC</sub>	5.5	12	16	V
Input Voltage Range1 (H+, H-, MIN, SSW, ZPER, SLOPE)	V <sub>IN1</sub>	0	-	V <sub>REF</sub> +0.3	V
Input Voltage Range2 (PWM)	V <sub>IN2</sub>	-0.3	-	6	V
PWM Input Duty Range	D <sub>PWM</sub>	0	-	100	%
PWM Input Frequency Range	f <sub>PWM</sub>	15	-	50	kHz

Electrical Characteristics (Unless otherwise specified Ta=25°C, V<sub>CC</sub>=12V)

Parameter	Symbol	Limit			Unit	Conditions	Characteristic Data
		Min	Typ	Max			
Circuit Current	I <sub>CC</sub>	3.0	4.5	6.5	mA		Figure 3
Output Voltage	V <sub>O</sub>	-	0.2	0.35	V	I <sub>O</sub> =±200mA, High and low side total	Figure 4 to Figure 7
Lock Detection ON Time	t <sub>ON</sub>	0.3	0.5	0.7	s		Figure 8
Lock Detection OFF Time	t <sub>OFF</sub>	3.0	5.0	7.0	s		Figure 9
Lock Detection OFF/ON Ratio	R <sub>LCK</sub>	8.5	10.0	11.5	-	R <sub>LCK</sub> =t <sub>OFF</sub> / t <sub>ON</sub>	Figure 10
FG Hysteresis Voltage+	V <sub>HYS+</sub>	7	12	17	mV		Figure 11
FG Hysteresis Voltage-	V <sub>HYS-</sub>	-5	-10	-15	mV		
FG Output Low Voltage	V <sub>FGL</sub>	-	-	0.30	V	I <sub>FG</sub> =5mA	Figure 12 to Figure 13
FG Output Leak Current	I <sub>FGL</sub>	-	-	10	μA	V <sub>FG</sub> =16V	Figure 14
PWM Input High Level Voltage	V <sub>PWMH</sub>	2.5	-	5.0	V		-
PWM Input Low Level Voltage	V <sub>PWML</sub>	0.0	-	1.0	V		-
PWM Input Current	I <sub>PWMH</sub>	-10	0	10	μA	V <sub>PWM</sub> =5V	Figure 15 to
	I <sub>PWML</sub>	-50	-25	-12	μA	V <sub>PWM</sub> =0V	Figure 16
Reference Voltage	V <sub>REF</sub>	3.0	3.3	3.6	V	I <sub>REF</sub> =-1mA	Figure 17 to Figure 18
Current Limit Setting Voltage	V <sub>CL</sub>	235	265	295	mV		Figure 19

For parameters involving current, positive notation means inflow of current to IC while negative notation means outflow of current from IC.

Typical Performance Curves (Reference Data)

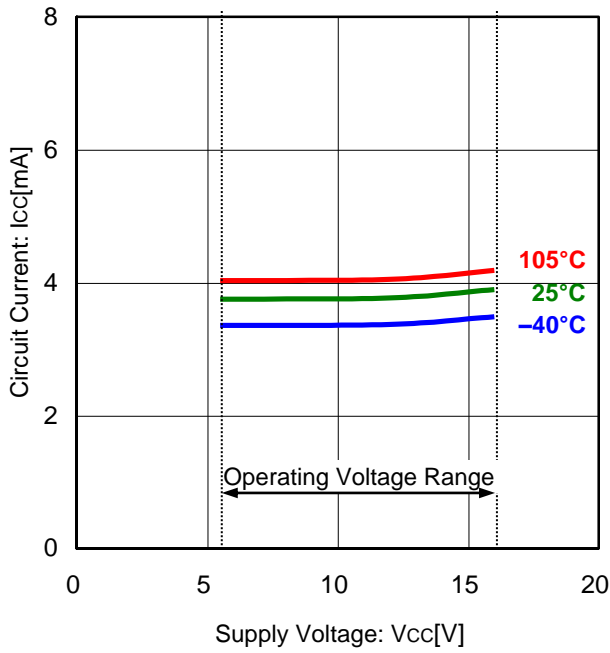

Figure 3. Circuit Current vs Supply Voltage

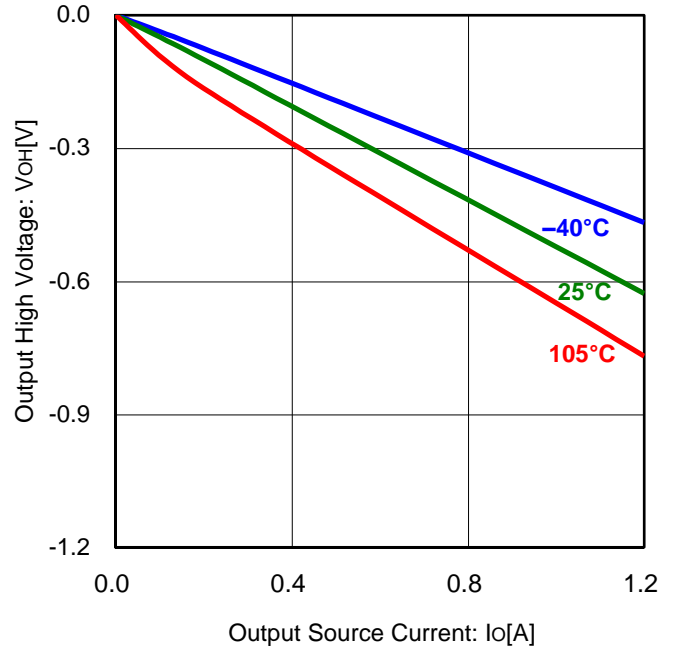

Figure 4. Output High Voltage vs Output Source Current (Vcc=12V)

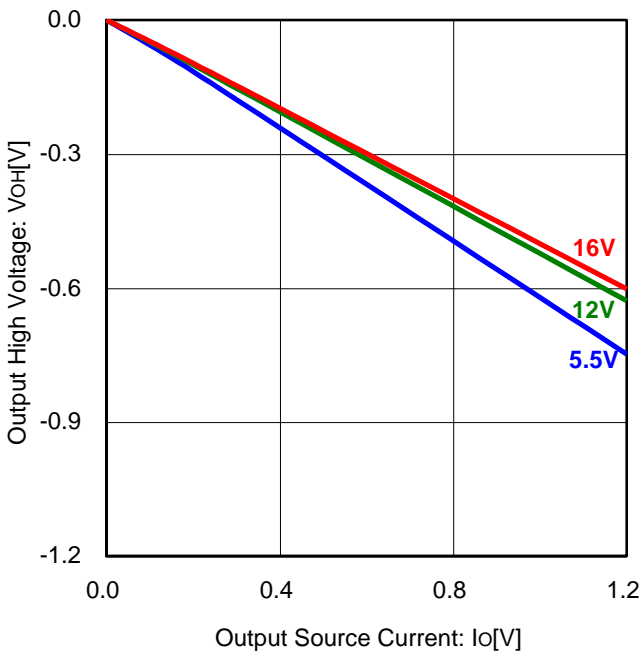

Figure 5. Output High Voltage vs Output Source Current

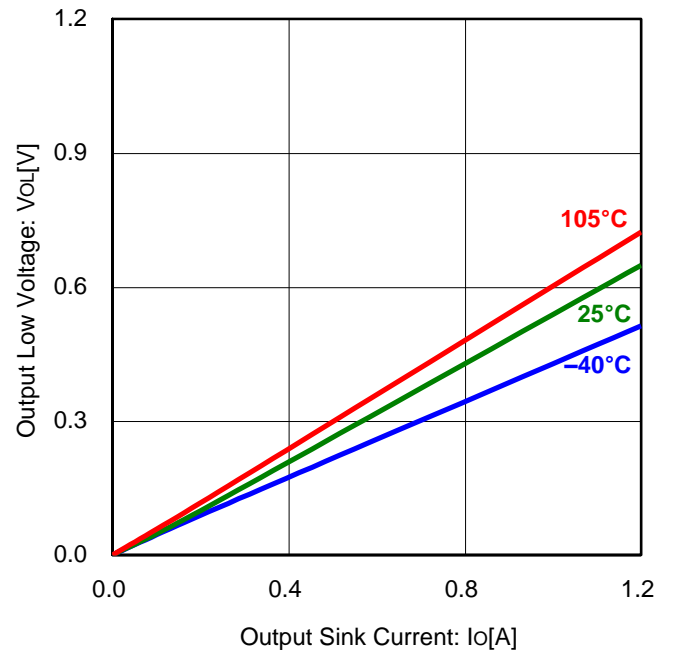

Figure 6. Output Low Voltage vs Output Sink Current (Vcc=12V)

Typical Performance Curves (Reference Data) – continued

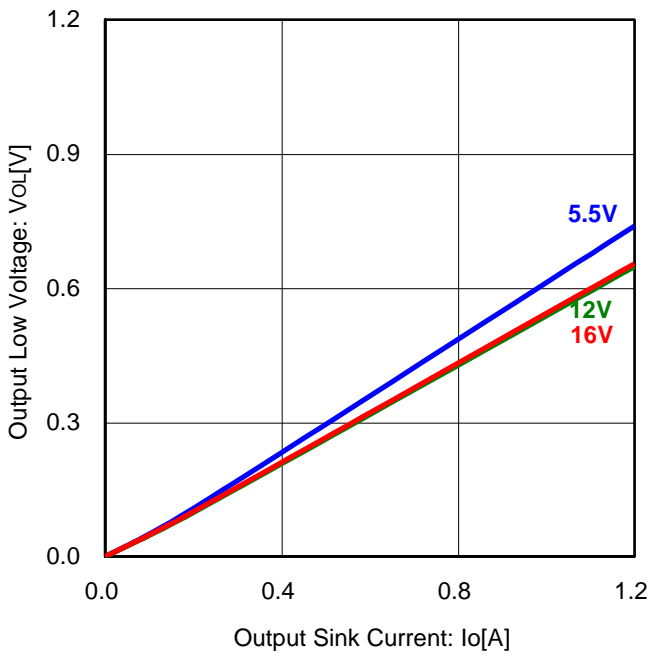

Figure 7. Output Low Voltage vs Output Sink Current ( $T_a=25^\circ\text{C}$ )

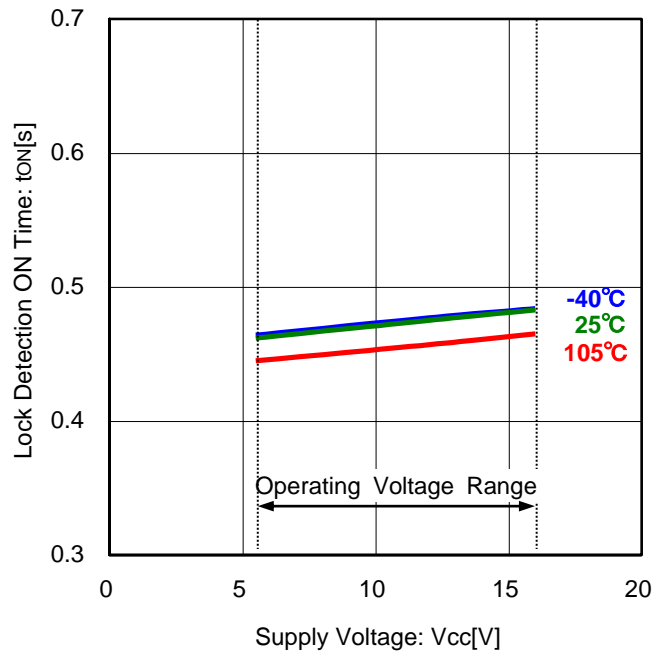

Figure 8. Lock Detection ON Time vs Supply Voltage

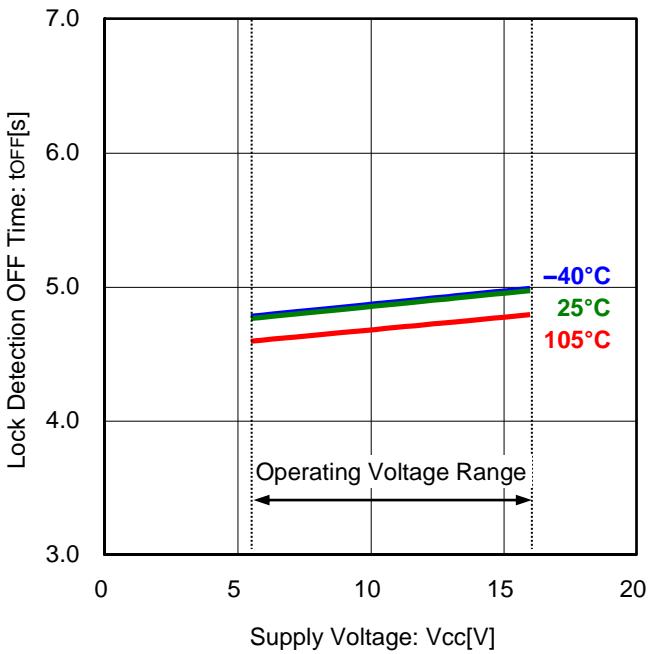

Figure 9. Lock Detection OFF Time vs Supply Voltage

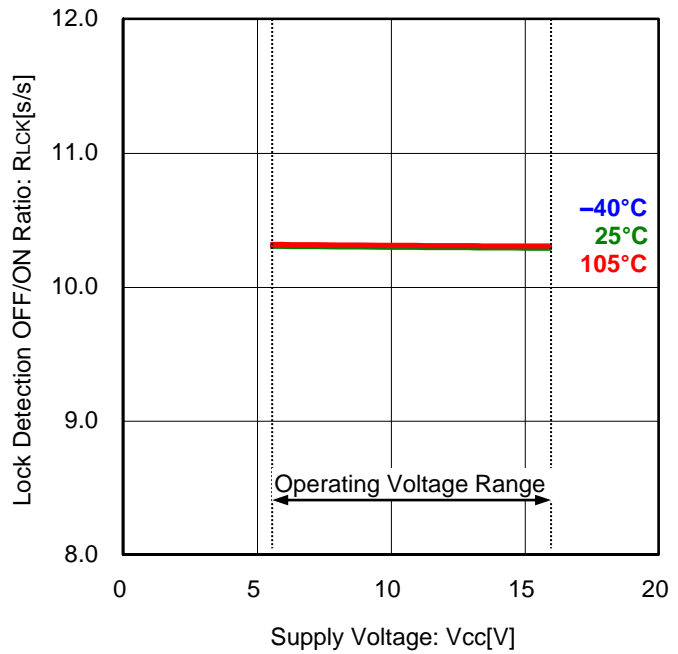

Figure 10. Lock Detection OFF/ON Ratio vs Supply Voltage

Typical Performance Curves (Reference Data) – continued

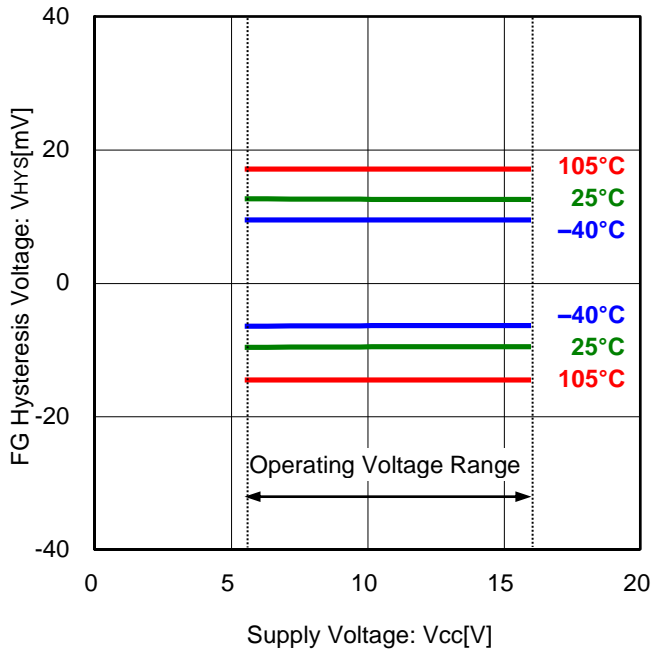

Figure 11. FG Hysteresis Voltage vs Supply Voltage

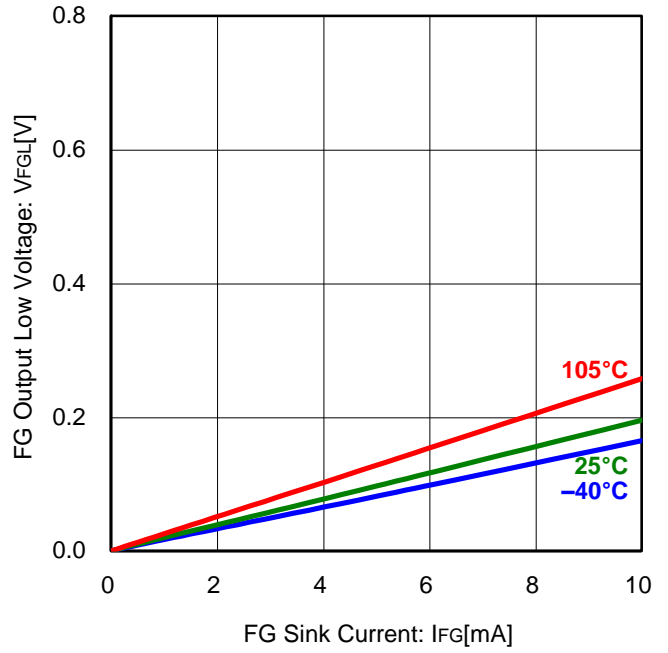

Figure 12. FG Output Low Voltage vs FG Sink Current (Vcc=12V)

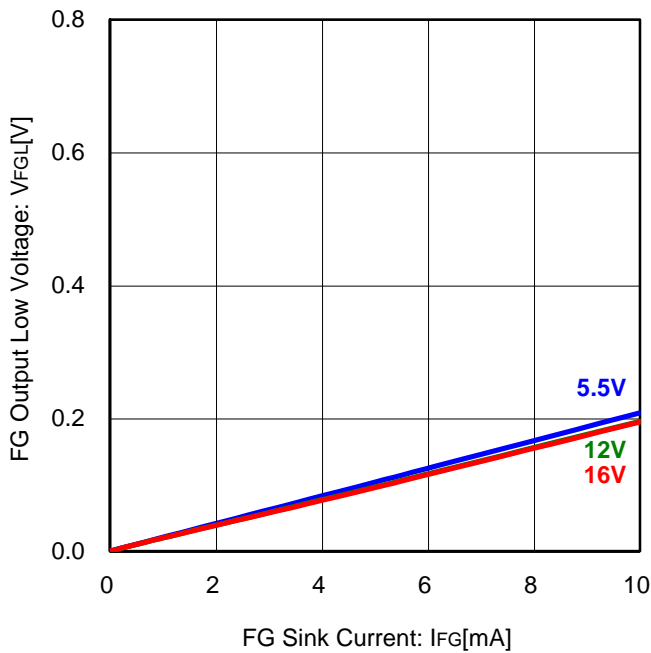

Figure 13. FG Output Voltage vs FG Sink Current (Ta=25°C)

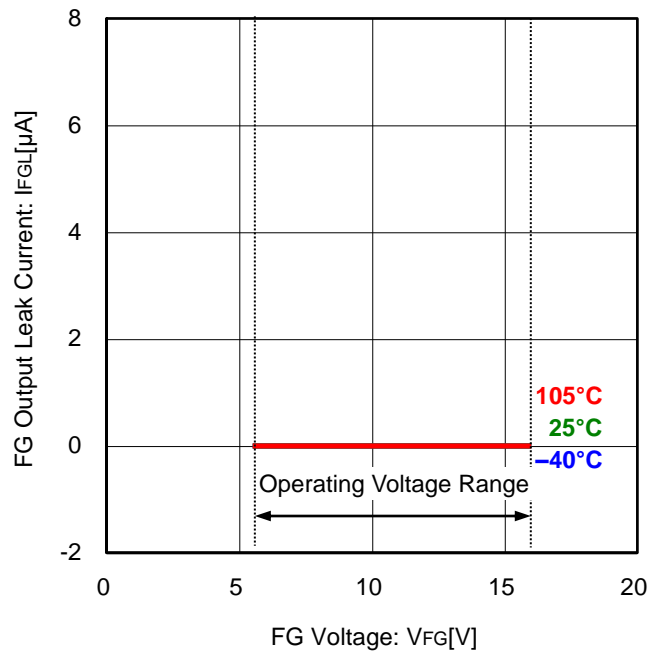

Figure 14. FG Output Leak Current vs FG Voltage

Typical Performance Curves (Reference Data) – continued

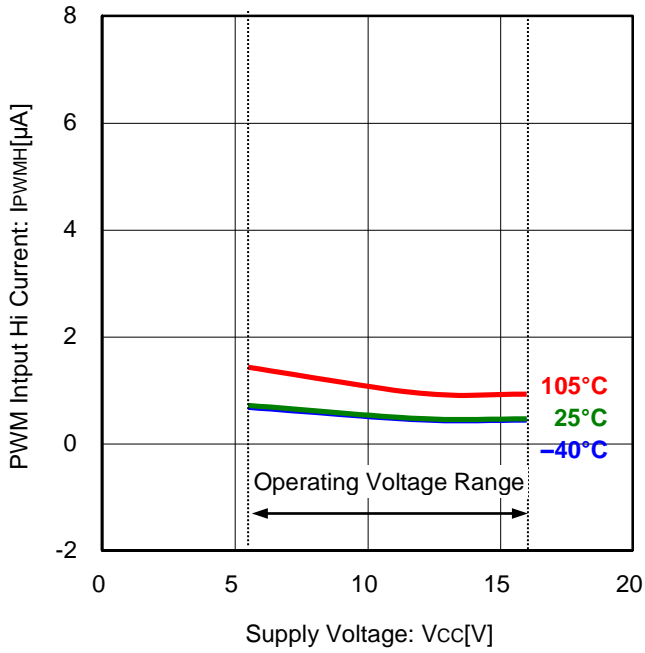

Figure 15. PWM Input Hi Current vs Supply Voltage

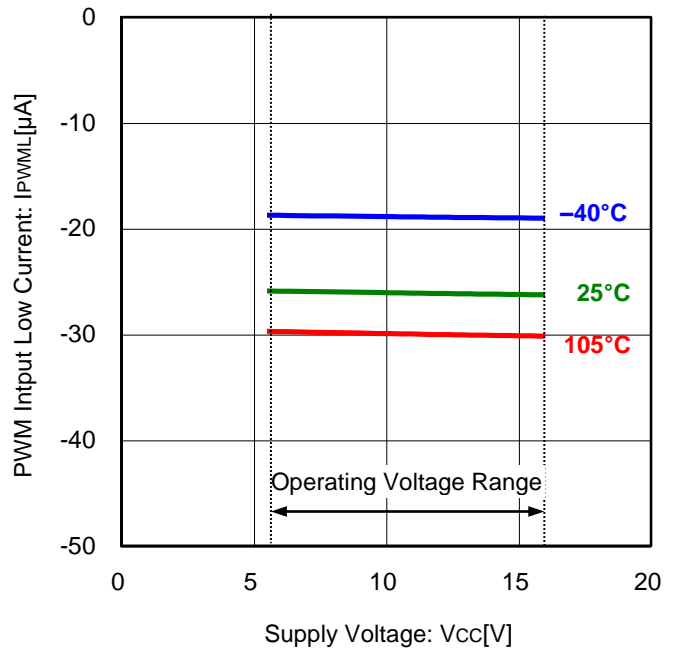

Figure 16. PWM Input Low Current vs Supply Voltage

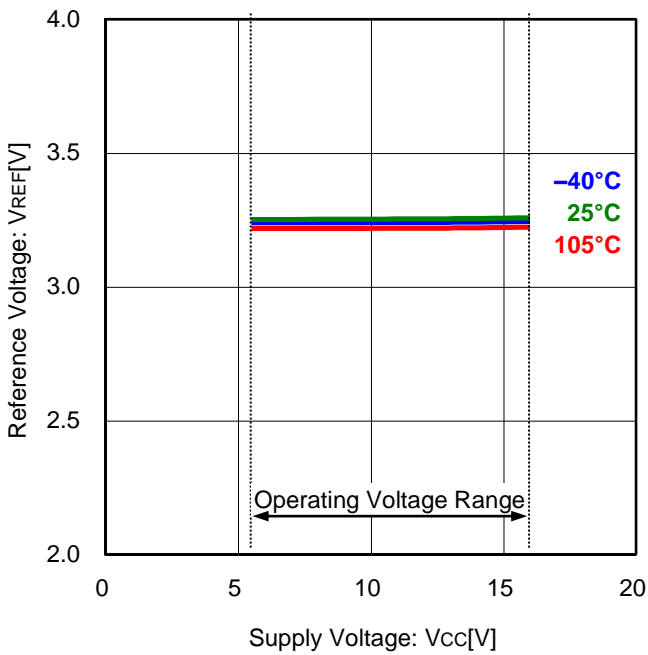

Figure 17. Reference Voltage vs Supply Voltage (IREF=-1mA)

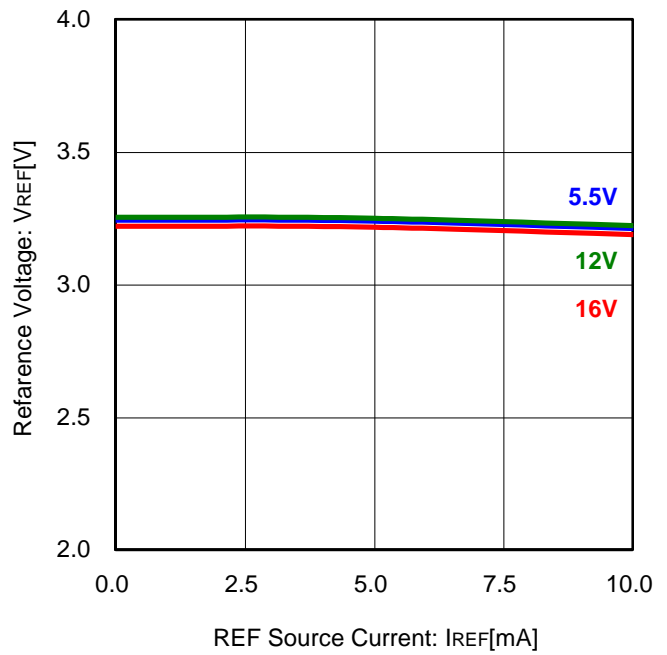

Figure 18. Reference Voltage vs REF Source Current (Ta=25°C)

Typical Performance Curves (Reference Data) – continued

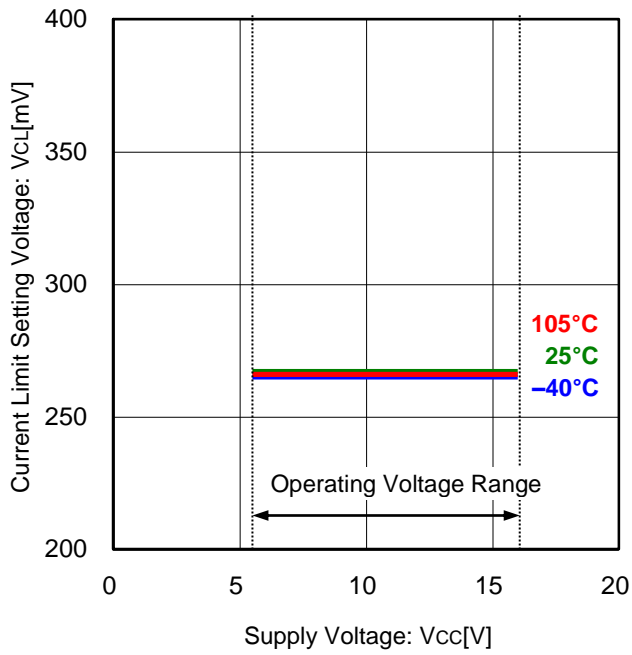

Figure 19. Current Limit Setting Voltage vs Supply Voltage

## Application Circuit Examples (Constant Values are for Reference)

### 1. PWM Input Application

It is an example of the application of the external PWM input, and controlling the rotational speed. In this application, minimum rotational speed can be set.

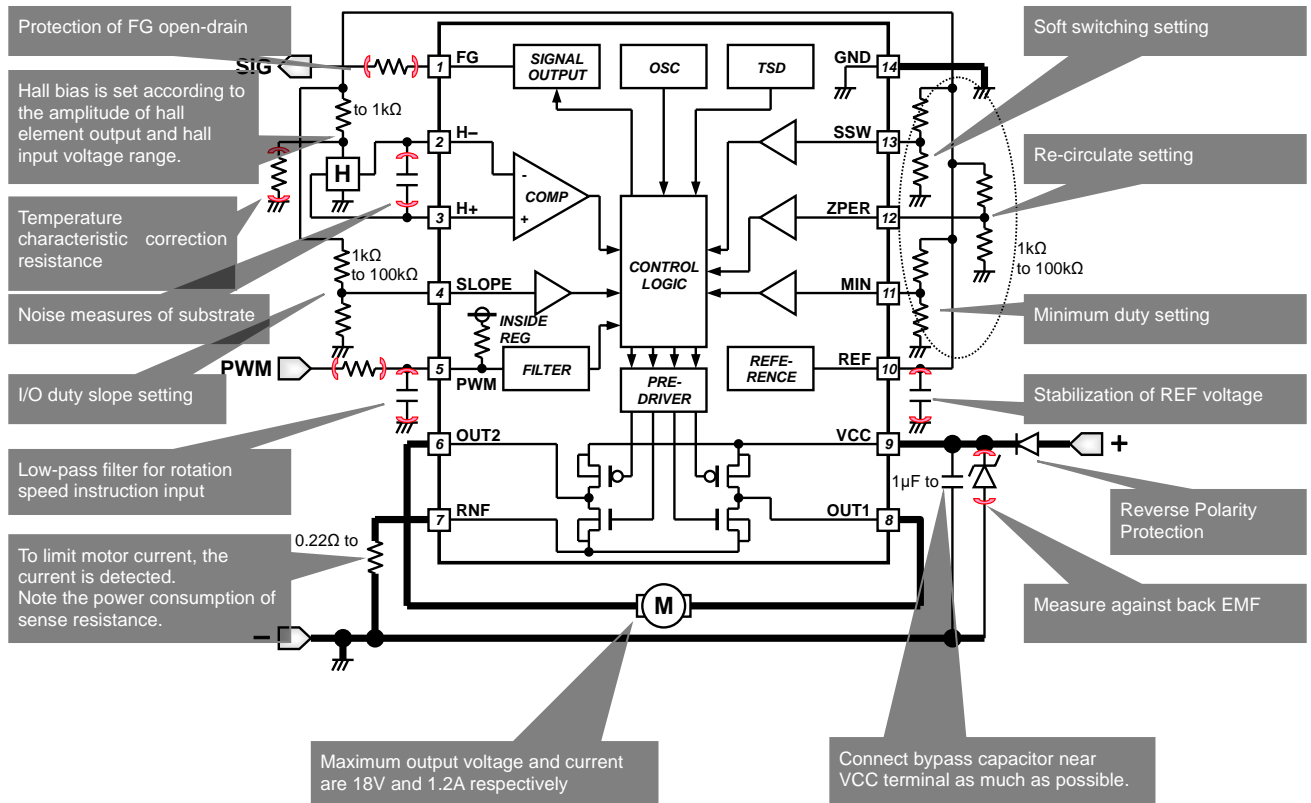

Figure 20. PWM Input Application

### Application Design Note

- (1) The bypass capacitor connected must be more than the recommended constant value because there is a possibility of the motor start-up failure etc. due to IC malfunction.

### Substrate Design Note

- (1) IC power(Vcc), motor outputs(OUT1, 2), and motor ground lines are made as wide as possible.
- (2) IC ground (GND) line is common with the application ground except motor ground (i.e. hall ground etc.), and arranged near to (-) land.
- (3) The bypass capacitor and/or Zener diode are placed near to VCC pin.
- (4) H+ and H- lines are arranged side by side and made from the hall element to IC as short as possible, because it is easy for the noise to influence the hall lines.

Application Circuit Examples (Constant Values are for Reference) – continued

2. DC Voltage Input Application

This is an example application circuit for the rotation speed control by DC voltage. In this application, minimum rotational speed cannot be set.

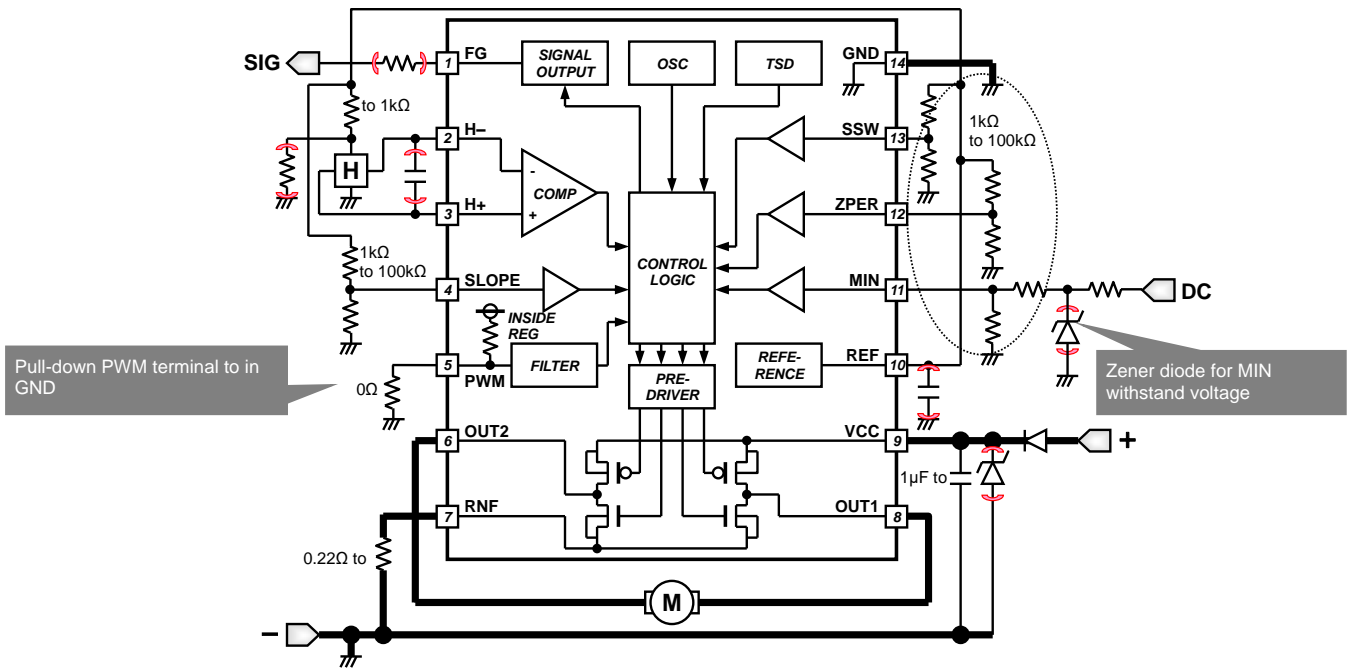

Figure 21. DC Voltage Input Application

**Functional Descriptions**

1. Variable Speed Operation

The rotational speed of the motor changes by the PWM duty of the motor outputs (OUT1 and OUT2 terminals). However, it provides for the motor's output not by the rotational speed but by the duty in the BD61243FV, because the rotational speed is not uniquely decided by the motor output duty. The changeable speed operation is controlled by these two input terminals.

(1) PWM Operation by Pulse Input in PWM Terminal

(2) PWM Operation by DC Input in MIN Terminal

(Note) PWM frequency of output is 50kHz (Typ). Hence, input PWM frequency is not equal to PWM frequency of output.

(1) PWM Operation by Pulse Input in PWM Terminal

The PWM signal from the controller can be input directly to IC in Figure 22. The output duty is controlled by the input PWM duty (Figure 23). Refer to recommended operating conditions (P.3) and electrical characteristics (P.4) for the input condition.

Internal power-supply voltage (INTERNAL REG; typ 5.0V) is impressed when the PWM terminal is open, it becomes 100% input of the duty and equivalent, and a full torque is driven. There must be a pull-down resistance outside of IC to make it to torque 0 when the PWM terminal opens (However, only at the controller of the complimentary output type.). Insert the protective resistance and capacitor for noise removal if necessary.

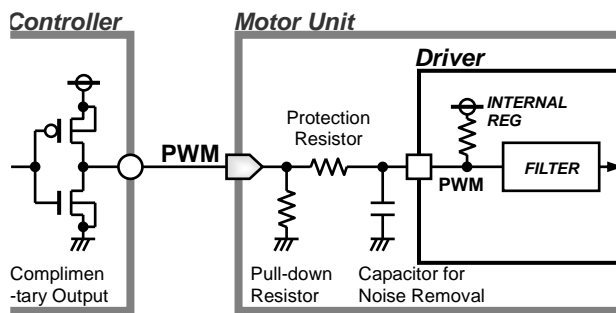

Figure 22. PWM Input Application

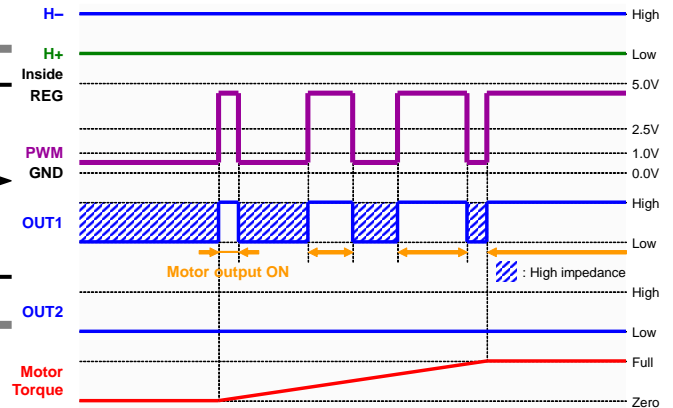

Figure 23. PWM Input Operation Timing Chart

Full torque ( $V_{PWM} > 2.5V$ ) and zero torque ( $< 1.0V$ ) can recognize the DC voltage input of the PWM terminal. However, the variable speed control in the DC voltage between 0V and 5.0V should be not able to be done.

(a) Setting of Minimum Output Duty (MIN)

Minimum rotational speed can be set by MIN terminal in Figure 24. The resolution of the MIN terminal is 128 steps. MIN terminal should be shorted to GND when this function is not used.

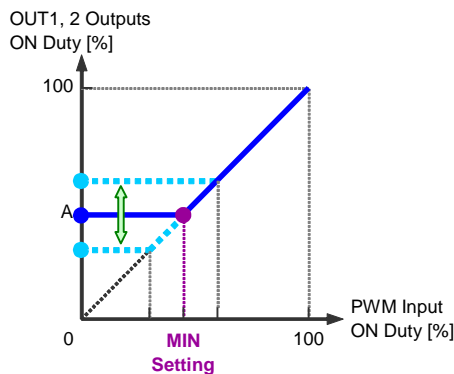

Figure 24. Setting of Minimum Output Duty

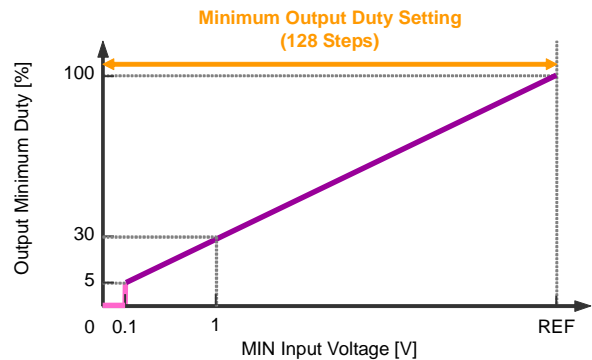

Figure 25. Relation of MIN Input Voltage and Output Duty

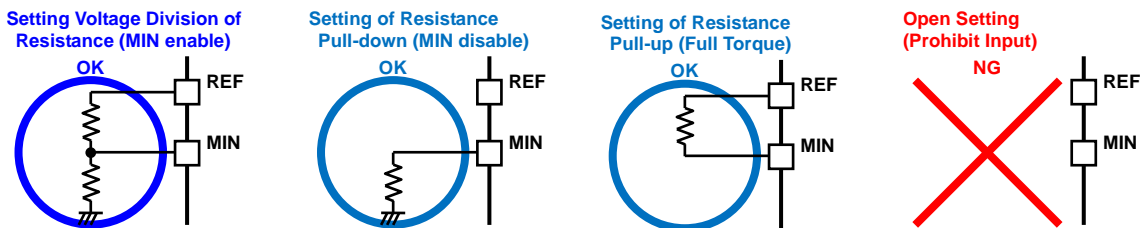

Figure 26. MIN Terminal Setting

Functional Descriptions – continued

(b) Setting of Slope of I/O Duty (SLOPE)

Slope of output duty and the input duty to PWM terminal can be established by SLOPE setting in Figure 27. The resolution of MIN is 128 steps. But if the voltage of the SLOPE terminal is 0.4V to 0.825V (Typ), then the slope of the input and output duty is fixed to 0.5, and if it is less than 0.4V (Typ) the slope is fixed to 1 (Figure 28). SLOPE terminal should be shorted to GND, when this function is not used.

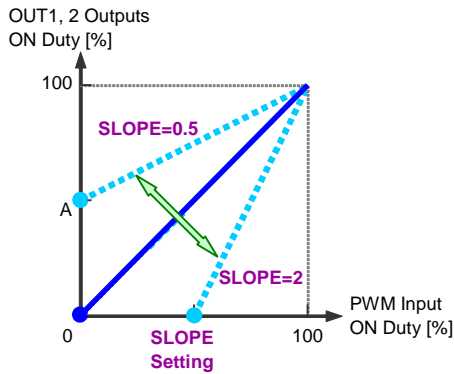

Figure 27. Adjust of Slope of I/O Duty

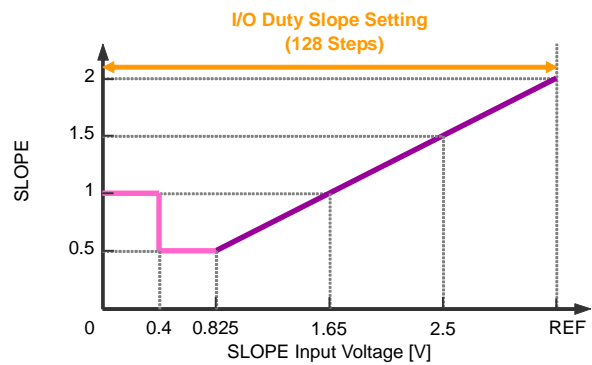

Figure 28. Relation of SLOPE Voltage and Slope of I/O Duty

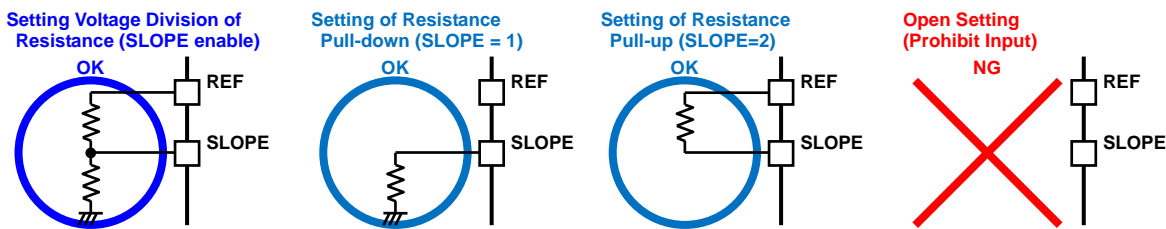

Figure 29. SLOPE Terminal Setting

When you perform the minimum rotation speed setting while making SLOPE setting, please decide MIN voltage based on a lower expression.

$$MIN\ Voltage = 3.3 \times \{ (Target\ Minimum\ Duty - 100 + 100 \times SLOPE) / (100 \times SLOPE) \} \dots Equation\ 1$$

(ex.) In the case of SLOPE=1 and Target minimum duty=20%, calculate the SLOPE and MIN voltage in the following.

The SLOPE voltage sets with SLOPE=0V from Figure 28.  
 The MIN voltage from Equation 1;  
 $MIN = 3.3 \times \{ (20 - 100 + 100 \times 1) / (100 \times 1) \}$   
 $= 0.66[V]$

(ex.) In the case of SLOPE=0.75 and Target minimum duty=40%, calculate the SLOPE and MIN voltage in the following.

The SLOPE voltage sets with SLOPE=1.24V from Figure 28.  
 The MIN voltage from Equation 1;  
 $MIN = 3.3 \times \{ (40 - 100 + 100 \times 0.75) / (100 \times 0.75) \}$   
 $= 0.66[V]$

(ex.) In the case of SLOPE=1.75 and Target minimum duty=30%, calculate the SLOPE and MIN voltage in the following.

The SLOPE voltage sets with SLOPE=2.9V from Figure 28.  
 The MIN voltage from Equation 1;  
 $MIN = 3.3 \times \{ (30 - 100 + 100 \times 1.75) / (100 \times 1.75) \}$   
 $= 1.98[V]$

(2) PWM Operation by DC Input in MIN Terminal

The output duty can be varied by inputting DC voltage into MIN terminal. PWM terminal should be shorted to GND when this function is used. Please refer to input voltage range 1(P.3) for the input condition of the MIN terminal. MIN Terminal voltage becomes unsettled when MIN terminal is in an open state. The voltage of the terminal becomes irregular if MIN terminal is open. Input voltages to MIN terminals when you turn on IC power supply (V<sub>CC</sub>) in Figure 30.

(Note)In the case of DC voltage input, it cannot set the lowest output duty.

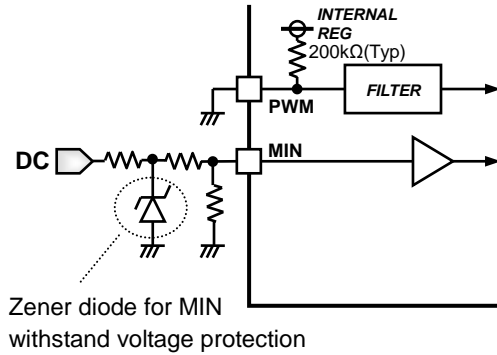

Figure 30. DC Input Application

(a) Setting of Slope of I/O Duty (SLOPE)

Slope of output duty and the input voltage to MIN terminal can be established by SLOPE setting in Figure 32. The resolution of SLOPE is 128 steps. But if the voltage of the SLOPE terminal is 0.4V to 0.825V (Typ), then the slope of the input and output duty is fixed to 0.5, and if it is less than 0.4V (Typ) the slope is fixed to 1 (Figure 28). SLOPE terminal should be shorted to GND, when this function is not used.

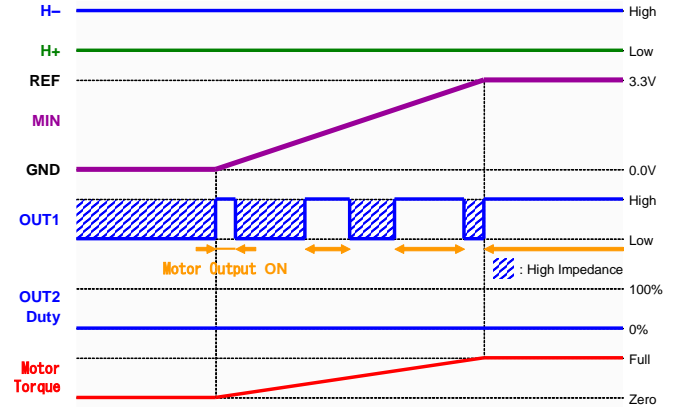

Figure 31. DC Input Operation Timing Chart

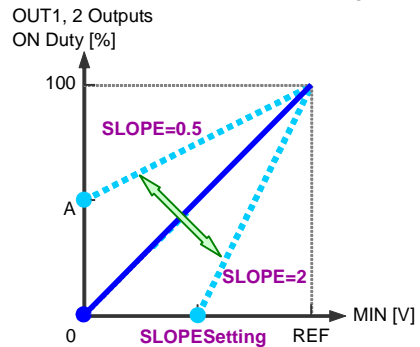

Figure 32. Relation of MIN Input Voltage and Slope of I/O Duty

**Functional Descriptions – continued**

2. About Setting of Phase Switching of Output

The period of Soft switching and re-circulate can be adjusted by SSW and ZPER setting.

(1) Soft Switching Period Setting (SSW)

The soft switching section in the output can be set by SSW terminal. By adjusting SSW voltage, soft switching section can be set from 22.5° to 90° as one period of hall signal 360°. The resolution of SSW is 128 steps in Figure 34. Timing chart is shown in Figure 33.

(Note)A soft switching period is the section where ON duty of the output changes from a target duty into 0% by 16 steps.

**Adjust a Soft Switching Period by SSW Setting**

Setable Range : Min22.5° to Max90°

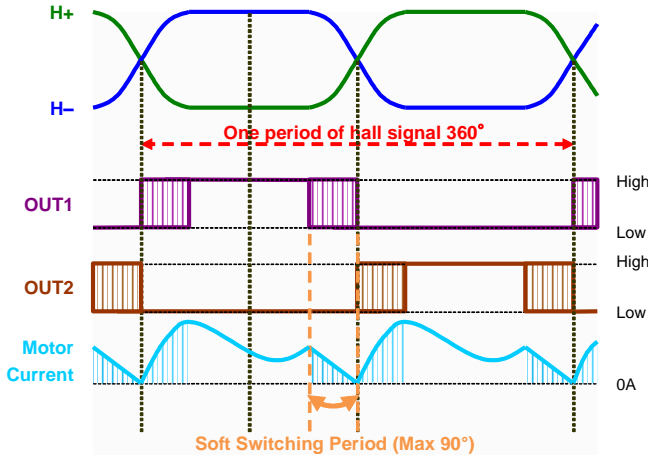

Figure 33. Soft switching Period setting

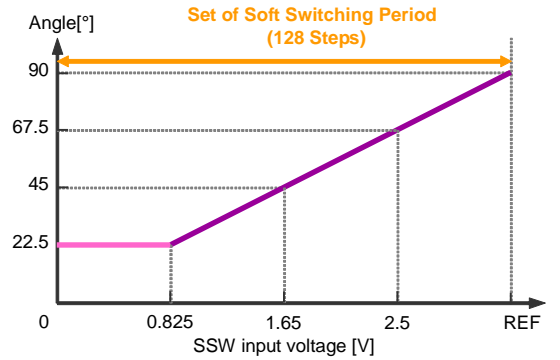

Figure 34. Relation of SSW Input Voltage and Soft Switching Period

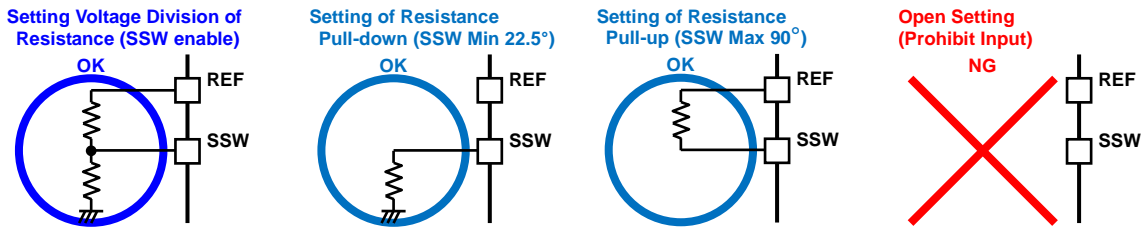

Figure 35. SSW Terminal Setting

Functional Descriptions – continued

(2) Re-circulate Period Setting (ZPER)

The recirculate period in fall of the output can be set by ZPER terminal. By adjusting ZPER voltage, recirculate period can be set from 0° to 90° as one period of hall signal 360° in Figure 37. The resolution of ZPER is 128 steps. Timing chart is shown in Figure 36.

About priority of SSW and ZPER setting, the setting priority of the period to recirculate than a soft switching period is high.

For example,  $V_{SSW}=1.65V$ ,  $V_{ZPER} = 0.825V$

$$\text{Soft switching period} = (1.65 / 3.3) \times 90^\circ - (0.825 / 3.3) \times 90^\circ = 45^\circ - 22.5^\circ = 22.5^\circ$$

$$\text{Re-circulate period} = (0.825 / 3.3) \times 90^\circ = 22.5^\circ$$

When you set a period to recirculate for longer than soft switching period, a soft switching section for 5.6° (Typ) enters.

\* A recirculate period is a current recirculate period before phase switching of output.  
 In the recirculate period, the logic of the output transistor is decided by the hall input logic.  
 The phase of output Hi becomes the high impedance, and the phase of output Low is Low.

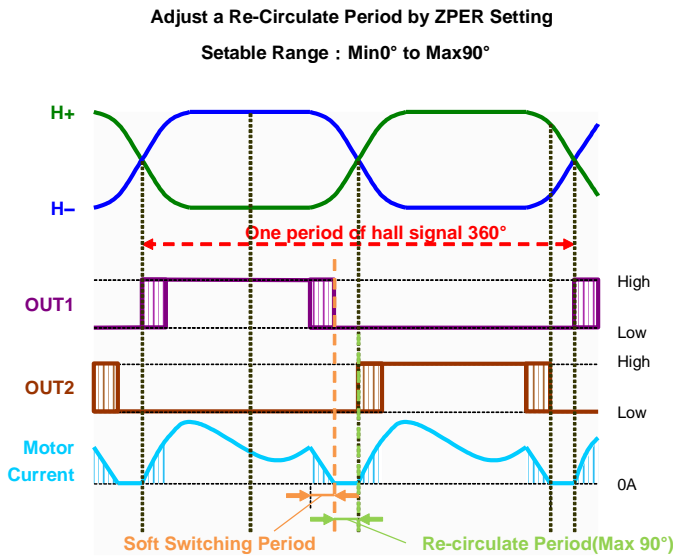

Figure 36. Re-circulate Period Setting

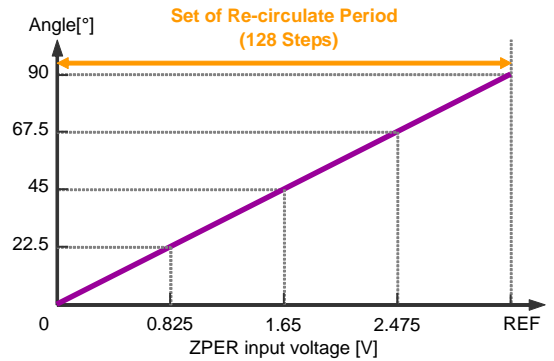

Figure 37. Relation of ZPER Input Voltage and Re-circulate Period

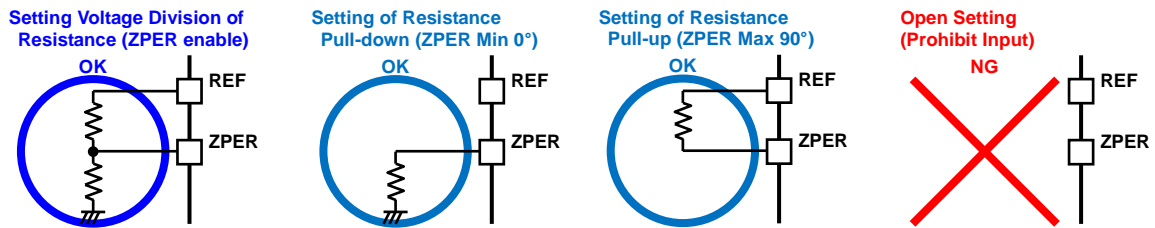

Figure 38. ZPER Terminal Setting

Functional Descriptions – continued

(3) Kickback Restraint Function (Lead angle correction)

Automatically detects a current phase gap, and an aspect change point is revised to lead angle.

When a current phase is delayed for a hall phase, output phase can be changed up to 22.5° automatically. Timing chart is shown in Figure 39 and 40.

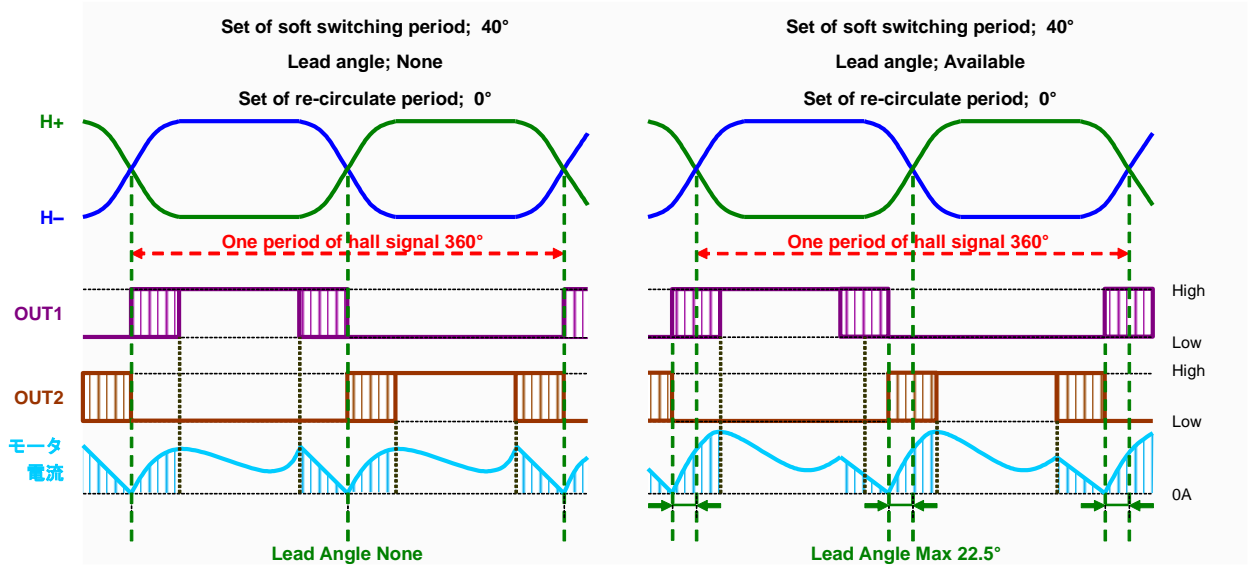

Figure 39. Normal Operation

Figure 40. Kickback Restraint Operation

A kickback restraint function is a miscellaneous function to prevent leaping up of the output voltage to occur at the time of power-on and a torque sudden change. Based on a setting method of SSW and ZPER of figure 41, please set that this function does not work in normal operation.

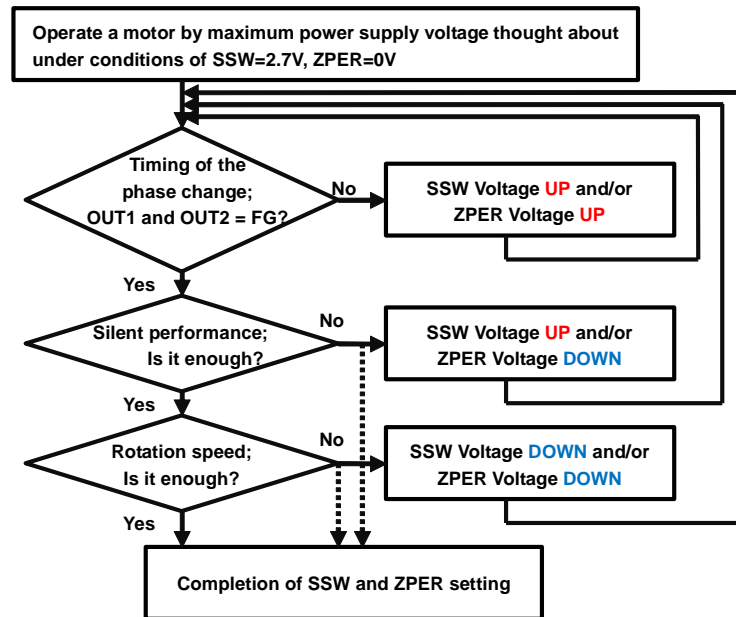

Figure 41. Flow of Setting of SSW and ZPER Terminal

Functional Descriptions – continued

3. Current Limit

The current limit circuit turns off the output, when the current that flows to the motor coil is detected exceeding a set value. The current value that current limit operates is determined by internal setting voltage and current sense resistor. In Figure 42,  $I_o$  is the current flowed to the motor coil,  $R_{NF}$  is the resistance detecting the current, and  $P_{RMAX}$  is the power

$$\begin{aligned}
 I_o[A] &= V_{CL}[V] / R_{NF}[\Omega] \\
 &= 265[mV] / 0.33[\Omega] \\
 &= 0.803[A] \\
 P_{RMAX}[W] &= V_{CL}[V] \times I_o[A] \\
 &= 265[mV] \times 0.803[A] \\
 &= 0.213[W]
 \end{aligned}$$

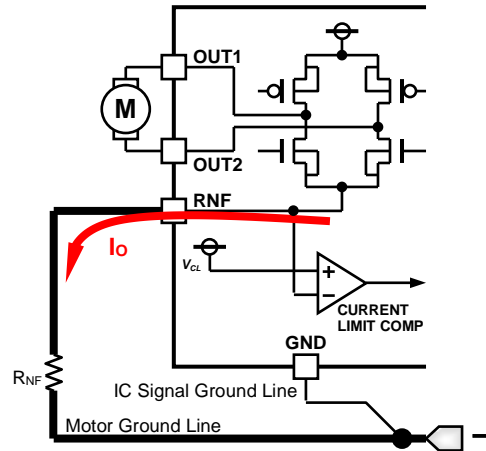

Figure 42. Setting of current limit and ground lines

4. Lock Protection and Automatic Restart

Motor rotation is detected by hall signal, and the IC internal counter set lock detection ON time ( $t_{ON}$ ) and OFF time ( $t_{OFF}$ ). Timing chart is shown in Figure 43.

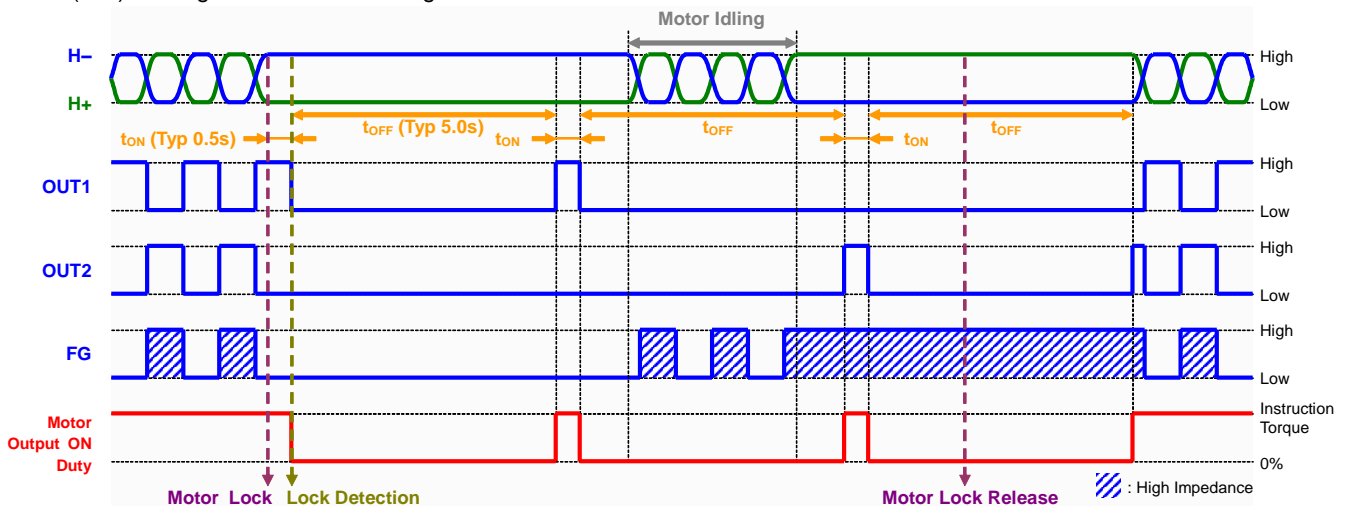

Figure 43. Lock Protection (Incorporated Counter System) Timing Chart

Functional Descriptions – continued

5. Quick Start

When torque off logic is input by the control signal over a fixed time, the lock protection function is disabled. The motor can restart quickly once the control signal is applied.

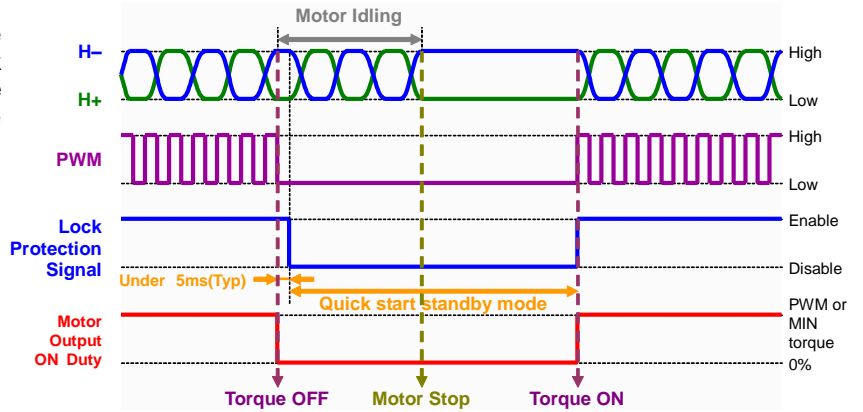

Figure 44. Quick Start Timing Chart (PWM Input Application)

6. Start Duty Assist

Start Duty Assist can secure a constant starting torque even at low duty. The IC is driven by a constant output duty ( $D_{OHL}$ ; Typ 50%) within detection of motor rotation. When Output ON duty is less than 50% (Typ), Start Duty Assist function operates under the following conditions:

- (1) Power ON
- (2) Automatic Restart
- (3) Quick Start
- (4) Thermal Shut Down(TSD) Release

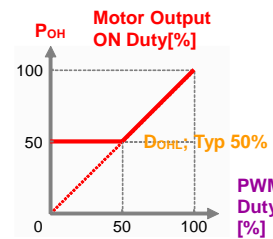

Figure 45. I/O Duty Characteristic in Start Duty Assist

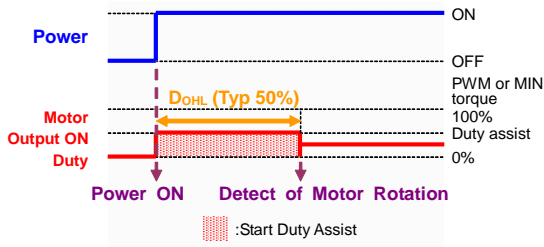

Figure 46. Timing Chart of Power ON

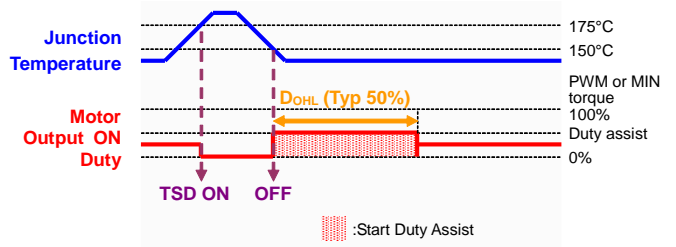

Figure 47. Timing Chart of TSD Release

Functional Descriptions – continued

7. Hall Input Setting

Hall input voltage range is shown in operating conditions (P.3). Adjust the value of hall element bias resistor  $R_1, R_2$  in Figure 49 so that the input voltage of a hall amplifier is input in "Input Voltage Range 1"(P.3) including signal amplitude.  $R_2$  is resistance to correct the temperature characteristic of the hall element.

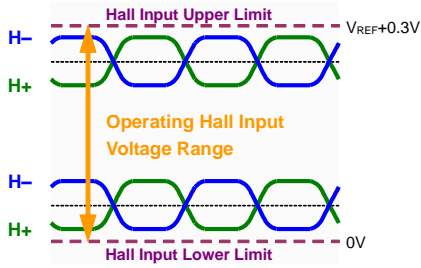

Figure 48. Hall Input Voltage Range

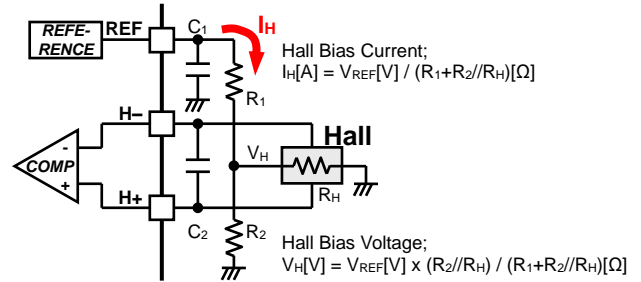

Figure 49. Hall Input Application

(1) Reducing the Noise of Hall Signal

$V_{CC}$  noise or the like depending on the wiring pattern of board may affect Hall element. In this case, place a capacitor like  $C_1$  in Figure 49. In addition, when wiring from the hall element output to IC hall input is long, noise may be induced on wiring. In this case, place a capacitor like  $C_2$ .

8. High-speed detection protection

High-speed detection protection begin lock protection action when it detects that the hall input signal is in an abnormal state (more than Typ 2.5kHz). Noise may be induced on wiring. In this case, place a capacitor like  $C_2$  in Figure 49.

**Safety Measure**

1. Reverse Connection Protection Diode

Reverse connection of power results in IC destruction as shown in Figure 50. When reverse connection is possible, reverse connection protection diode must be added between power supply and V<sub>CC</sub>.

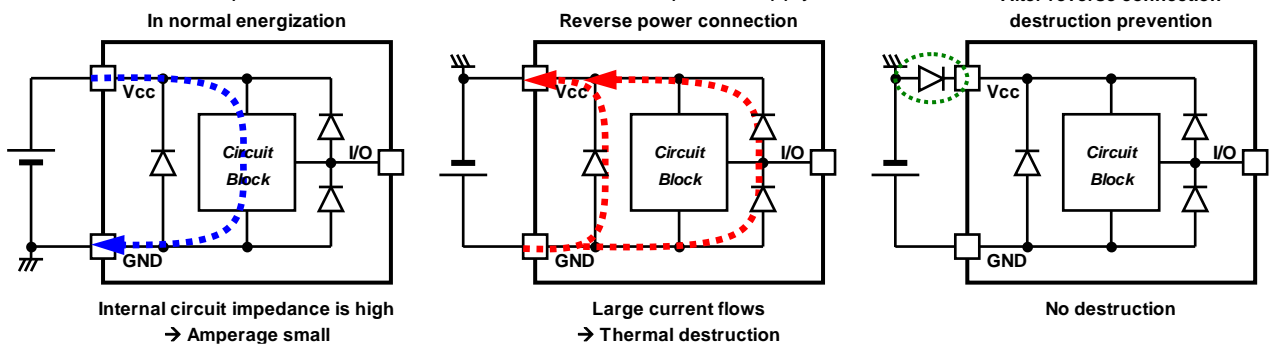

Figure 50. Flow of Current When Power is Connected Reversely

2. Protection against V<sub>CC</sub> Voltage Rise by Back Electromotive Force

Back electromotive force (Back EMF) generates regenerative current to power supply. However, when reverse connection protection diode is connected, V<sub>CC</sub> voltage rises because the diode prevents current flow to power supply.

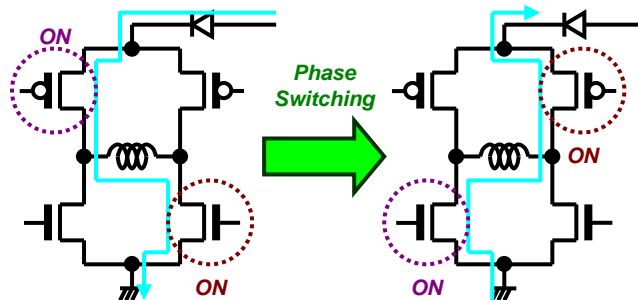

Figure 51. V<sub>CC</sub> Voltage Rise by Back Electromotive Force

When the absolute maximum rated voltage may be exceeded due to voltage rise by back electromotive force, place (A) Capacitor or (B) Zener diode between V<sub>CC</sub> and GND. If necessary, add both (C).

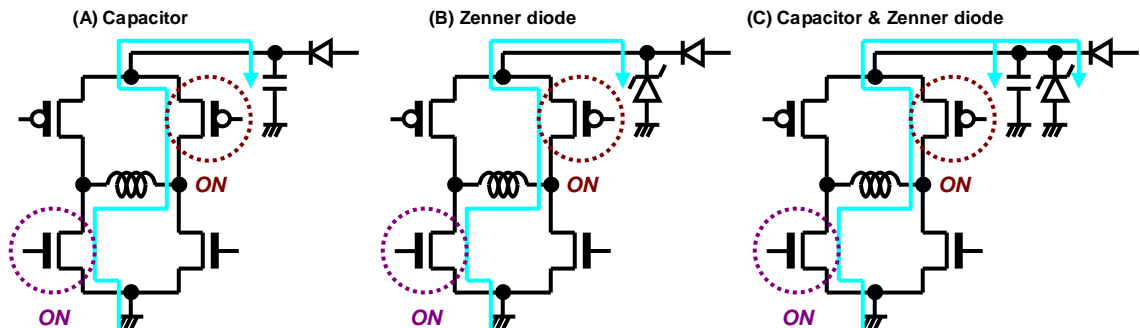

Figure 52. Measure against V<sub>CC</sub> and Motor Driving Outputs Voltage

3. Problem of GND line PWM Switching

Do not perform PWM switching of GND line because GND terminal potential cannot be kept to a minimum.

4. Protection of Rotation Speed Pulse (FG) Open-Drain Output

FG output is an open drain and requires pull-up resistor. Adding resistor can protect the IC. Exceeding the absolute maximum rating, when FG terminal is directly connected to power supply, could damage the IC.

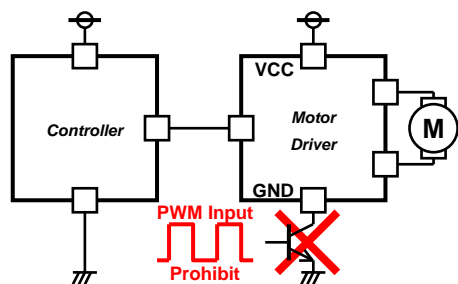

Figure 53. GND Line PWM Switching Prohibited

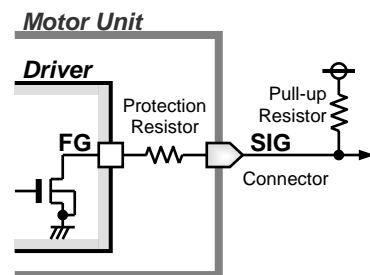

Figure 54. Protection of FG Terminal

## Power Consumption

### 1. Current Pathway

The current pathways that relates to driver IC are the following, and shown in Figure 55.

- (1) Circuit Current ( $I_{CC}$ )
- (2) Motor Current ( $I_M$ )
- (3) Reference Bias Current to the Resistors ( $I_{REF}$ )
- (4) FG Output Sink Current ( $I_{FG}$ )

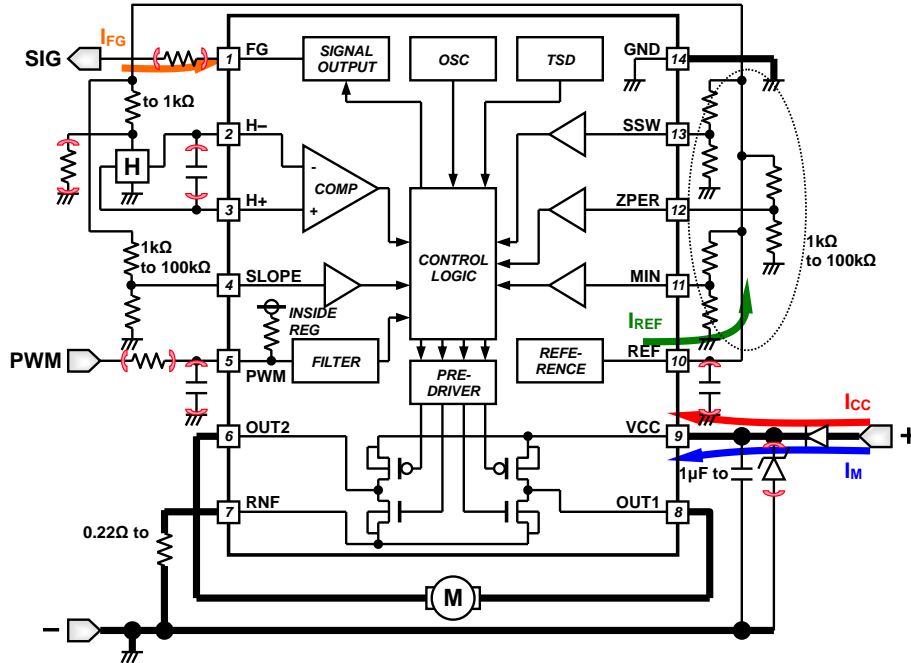

Figure 55. Current Pathway of IC

### 2. Calculation of Power Consumption

#### (1) Circuit Current ( $I_{CC}$ )

$$P_{W1}[W] = V_{CC}[V] \times I_{CC}[A] \quad (I_{CC} \text{ current doesn't include } I_M, I_{REF})$$

$$\text{(ex.) } V_{CC} = 11.3[V], I_{CC} = 4.5[mA]$$

$$P_{W1}[W] = 11.3[V] \times 4.5[mA] = 50.85 [mW]$$

#### (2) Motor Driving Current ( $I_M$ )

$V_{OH}$  is the output saturation voltage of OUT1 or OUT2 high side,  $V_{OL}$  is the other low side voltage,

$$P_{W2}[W] = (V_{OH}[V] + V_{OL}[V]) \times I_M[A]$$

$$\text{(ex.) } V_{OH} = 0.10[V], V_{OL} = 0.10[V], I_M = 200[mA]$$

$$P_{W2}[W] = (0.10[V] + 0.10[V]) \times 200[mA] = 40.0[mW]$$

#### (3) Reference Bias Current to the LPF and Resistors ( $I_{REF}$ )

$$P_{W3}[W] = (V_{CC}[V] - V_{REF}[V]) \times I_{REF}[A]$$

$$\text{(ex.) } I_{REF} = 6.0[mA]$$

$$P_{W3}[W] = (11.3[V] - 3.3[V]) \times 6.0[mA] = 48.0[mW]$$

#### (4) FG(AL) Output Sink Current ( $I_{FG}$ )

$$P_{W4}[W] = V_{FG}[V] \times I_{FG}[A]$$

$$\text{(ex.) } V_{FG} = 0.10[V], I_{FG} = 5.0[mA]$$

$$P_{W4}[W] = 0.10[V] \times 5.0[mA] = 0.5[mW]$$

Total power consumption of driver IC becomes the following by the above (1) to (4).

$$P_{W_{\text{tot}}}[W] = P_{W1}[W] + P_{W2}[W] + P_{W3}[W] + P_{W4}[W]$$

$$\text{(ex.) } P_{W_{\text{tot}}}[W] = 50.85[mW] + 40.0[mW] + 48.0[mW] + 0.5[mW] = 139.35[mW]$$

Refer to next page, when you calculate the chip surface temperature ( $T_j$ ) and the package surface temperature ( $T_c$ ) by using the power consumption value.

**Power Dissipation**

1. Power Dissipation

Power dissipation (total loss) indicates the power that can be consumed by IC at Ta=25°C (normal temperature). IC is heated when it consumes power, and the temperature of IC chip becomes higher than ambient temperature. The temperature that can be accepted by IC chip into the package, that is junction temperature of the absolute maximum rating, depends on circuit configuration, manufacturing process, etc. Power dissipation is determined by this maximum joint temperature, the thermal resistance in the state of the substrate mounting, and the ambient temperature. Therefore, when a power dissipation that provides by the absolute maximum rating is exceeded, the operating temperature range is not a guarantee. The maximum junction temperature is in general equal to the maximum value in the storage temperature range.

$$\theta_{ja} = (T_j - T_a) / P \text{ [}^\circ\text{C/W]}$$

2. Thermal Resistance

Heat generated by consumed power of IC is radiated from the mold resin or lead frame of package. The parameter which indicates this heat dissipation capability (hardness of heat release) is called thermal resistance. In the state of the substrate mounting, thermal resistances from the chip junction to the ambience and to the package surface are shown respectively with  $\theta_{ja}$ [°C/W] and  $\theta_{jc}$ [°C/W]. Thermal resistance is classified into the package part and the substrate part, and thermal resistance in the package part depends on the composition materials such as the mold resins and the lead frames. On the other hand, thermal resistance in the substrate part depends on the substrate heat dissipation capability of the material, the size, and the copper foil area etc. Therefore, thermal resistance can be decreased by the heat radiation measures like installing a heat sink etc. in the mounting substrate. The thermal resistance model and calculations are shown in Figure 56.

$$\theta_{jc} = 36 \text{ [}^\circ\text{C/W]} \text{ (Reference Value)}$$

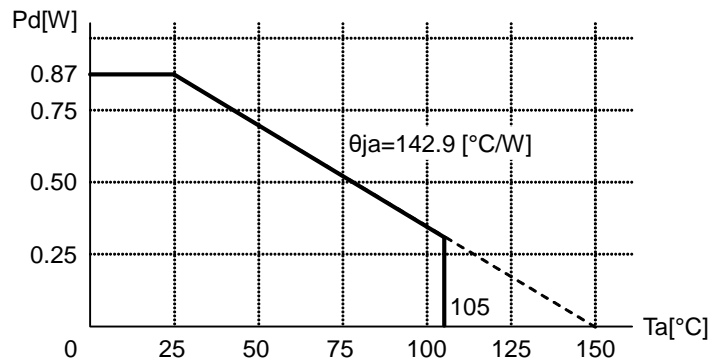
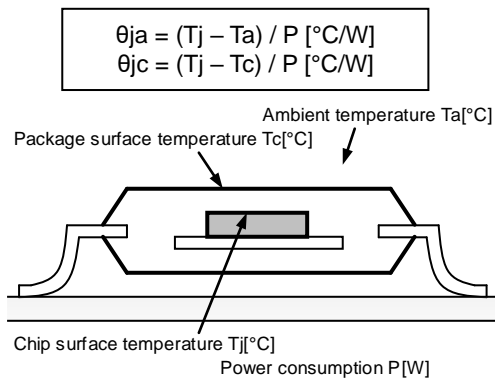

(Note) Reduce by 7.0mW/°C when operating over Ta=25°C (Mounted on 70.0mm x 70.0mm x 1.6mm glass epoxy board)

Figure 56. Thermal Resistance Model of Surface Mount

Figure 57. Power Dissipation vs Ambient Temperature

**I/O Equivalence Circuit (Resistance Values are Typical)**

1. Power supply terminal, Ground terminal

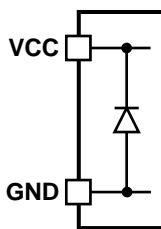

2. PWM input duty terminal

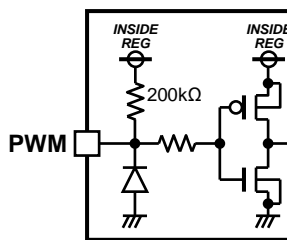

3. Hall +/- input terminal

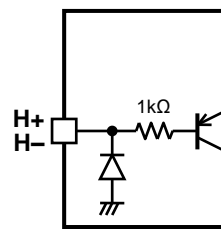

4. I/O duty slope setting terminal, Minimum output duty setting terminal, Recirculate period setting terminal and Soft switching setting terminal

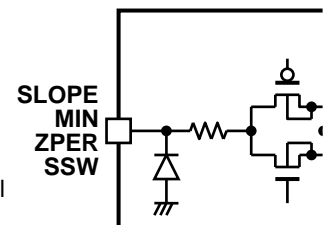

5. Reference voltage output terminal

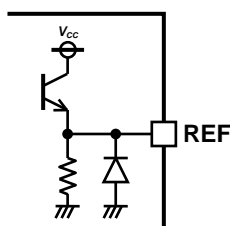

6. Motor output terminal 1/2, Output current detecting resistor connecting terminal

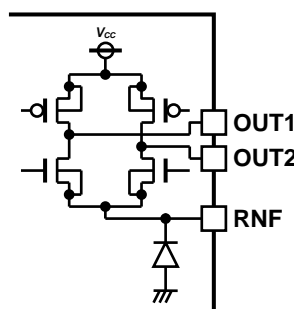

7. Speed pulse signal output terminal

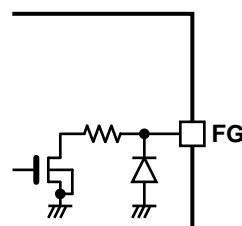

## Operational Notes

### 1. Reverse Connection of Power Supply

Connecting the power supply in reverse polarity can damage the IC. Take precautions against reverse polarity when connecting the power supply, such as mounting an external diode between the power supply and the IC's power supply pins.

### 2. Power Supply Lines

Design the PCB layout pattern to provide low impedance supply lines. Furthermore, connect a capacitor to ground at all power supply pins. Consider the effect of temperature and aging on the capacitance value when using electrolytic capacitors.

### 3. Ground Voltage

Ensure that no pins are at a voltage below that of the ground pin at any time, even during transient condition. However, pins that drive inductive loads (e.g. motor driver outputs, DC-DC converter outputs) may inevitably go below ground due to back EMF or electromotive force. In such cases, the user should make sure that such voltages going below ground will not cause the IC and the system to malfunction by examining carefully all relevant factors and conditions such as motor characteristics, supply voltage, operating frequency and PCB wiring to name a few.

### 4. Ground Wiring Pattern

When using both small-signal and large-current ground traces, the two ground traces should be routed separately but connected to a single ground at the reference point of the application board to avoid fluctuations in the small-signal ground caused by large currents. Also ensure that the ground traces of external components do not cause variations on the ground voltage. The ground lines must be as short and thick as possible to reduce line impedance.

### 5. Thermal Consideration

Should by any chance the power dissipation rating be exceeded the rise in temperature of the chip may result in deterioration of the properties of the chip. In case of exceeding this absolute maximum rating, increase the board size and copper area to prevent exceeding the Pd rating.

### 6. Recommended Operating Conditions

These conditions represent a range within which the expected characteristics of the IC can be approximately obtained. The electrical characteristics are guaranteed under the conditions of each parameter.

### 7. Inrush Current

When power is first supplied to the IC, it is possible that the internal logic may be unstable and inrush current may flow instantaneously due to the internal powering sequence and delays, especially if the IC has more than one power supply. Therefore, give special consideration to power coupling capacitance, power wiring, width of ground wiring, and routing of connections.

### 8. Operation Under Strong Electromagnetic Field

Operating the IC in the presence of a strong electromagnetic field may cause the IC to malfunction.

### 9. Testing on Application Boards

When testing the IC on an application board, connecting a capacitor directly to a low-impedance output pin may subject the IC to stress. Always discharge capacitors completely after each process or step. The IC's power supply should always be turned off completely before connecting or removing it from the test setup during the inspection process. To prevent damage from static discharge, ground the IC during assembly and use similar precautions during transport and storage.

## Operational Notes – continued

**10. Inter-pin Short and Mounting Errors**

Ensure that the direction and position are correct when mounting the IC on the PCB. Incorrect mounting may result in damaging the IC. Avoid nearby pins being shorted to each other especially to ground, power supply and output pin. Inter-pin shorts could be due to many reasons such as metal particles, water droplets (in very humid environment) and unintentional solder bridge deposited in between pins during assembly to name a few.

**11. Unused Input Pins**

Input pins of an IC are often connected to the gate of a MOS transistor. The gate has extremely high impedance and extremely low capacitance. If left unconnected, the electric field from the outside can easily charge it. The small charge acquired in this way is enough to produce a significant effect on the conduction through the transistor and cause unexpected operation of the IC. So unless otherwise specified, unused input pins should be connected to the power supply or ground line.

**12. Regarding the Input Pin of the IC**

This monolithic IC contains P+ isolation and P substrate layers between adjacent elements in order to keep them isolated. P-N junctions are formed at the intersection of the P layers with the N layers of other elements, creating a parasitic diode or transistor. For example (refer to figure below):

When  $GND > Pin A$  and  $GND > Pin B$ , the P-N junction operates as a parasitic diode.  
When  $GND > Pin B$ , the P-N junction operates as a parasitic transistor.

Parasitic diodes inevitably occur in the structure of the IC. The operation of parasitic diodes can result in mutual interference among circuits, operational faults, or physical damage. Therefore, conditions that cause these diodes to operate, such as applying a voltage lower than the GND voltage to an input pin (and thus to the P substrate) should be avoided.

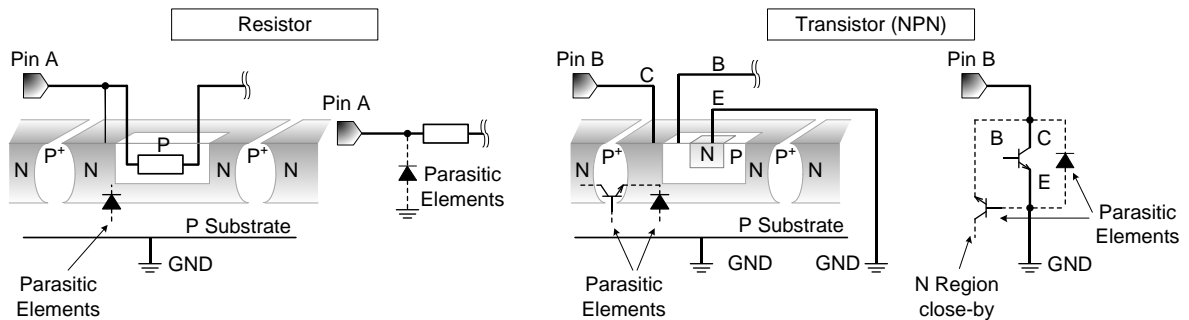

Figure 58. Example of monolithic IC structure

**13. Ceramic Capacitor**

When using a ceramic capacitor, determine the dielectric constant considering the change of capacitance with temperature and the decrease in nominal capacitance due to DC bias and others.

**14. Area of Safe Operation (ASO)**

Operate the IC such that the output voltage, output current, and power dissipation are all within the Area of Safe Operation (ASO).

**15. Thermal Shutdown (TSD) Circuit**

This IC has a built-in thermal shutdown circuit that prevents heat damage to the IC. Normal operation should always be within the IC's power dissipation rating. If however the rating is exceeded for a continued period, the junction temperature will rise which will activate the TSD circuit that will turn OFF all output pins. When the junction temperature falls below the TSD threshold, the circuits are automatically restored to normal operation.

Note that the TSD circuit operates in a situation that exceeds the absolute maximum ratings and therefore, under no circumstances, should the TSD circuit be used in a set design or for any purpose other than protecting the IC from heat damage.

Physical Dimension, Tape and Reel Information

Package Name	SSOP-B14
--------------	----------

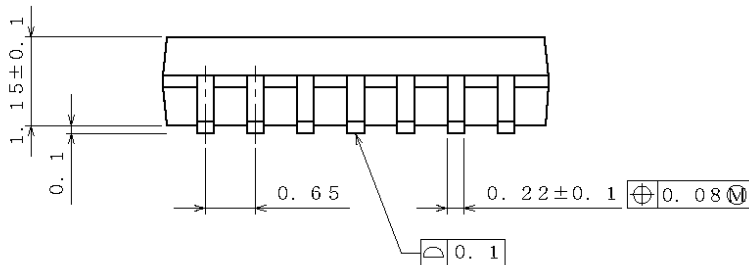
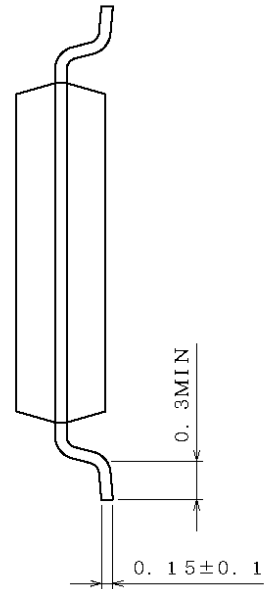
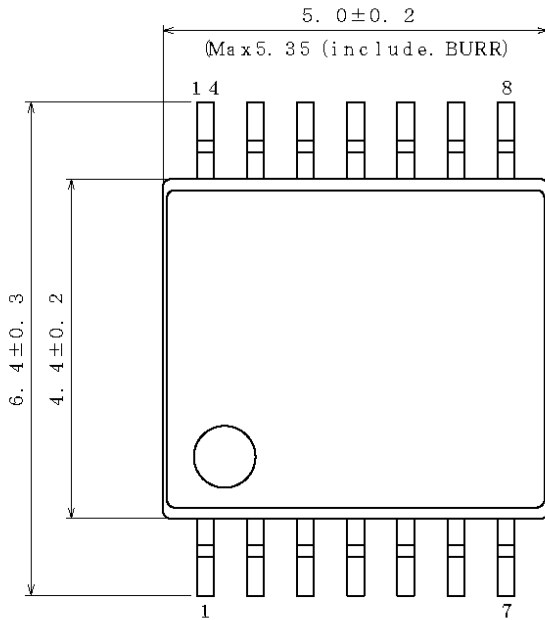

(UNIT : mm)

PKG : SSOP-B14

Drawing No. EX152-5002

**<Tape and Reel information>**

Tape	Embossed carrier tape
Quantity	2500pcs
Direction of feed	E2 ( The direction is the 1pin of product is at the upper left when you hold reel on the left hand and you pull out the tape on the right hand )

Reel

1pin

Direction of feed

\*Order quantity needs to be multiple of the minimum quantity.

Ordering Information

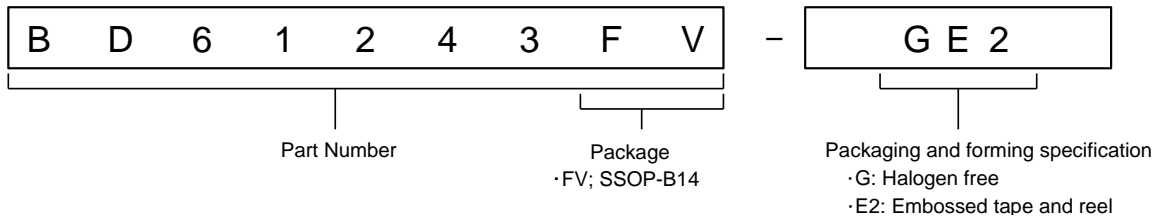

Marking Diagram

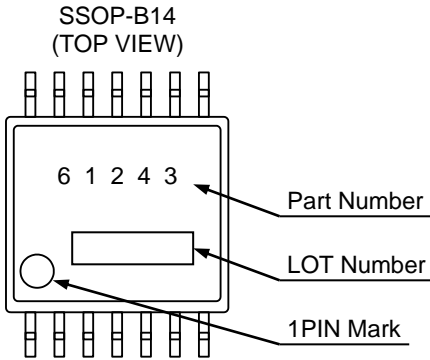

Revision History

Date	Revision	Changes
Jun.19.2015	001	New Release
Mar.31.2021	002	Updated packages and part numbers P.27-2, P.27-3

Ordering Information

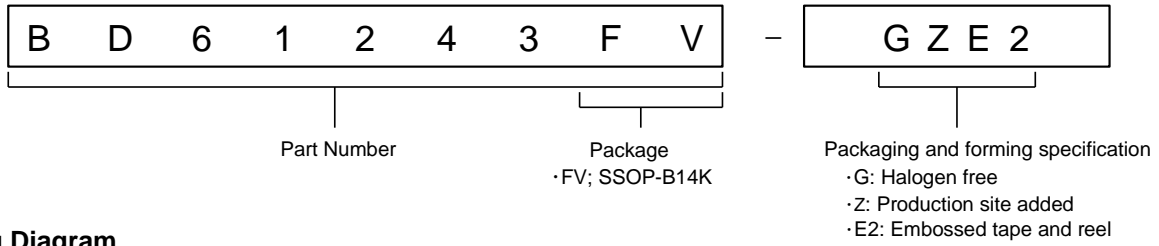

Marking Diagram

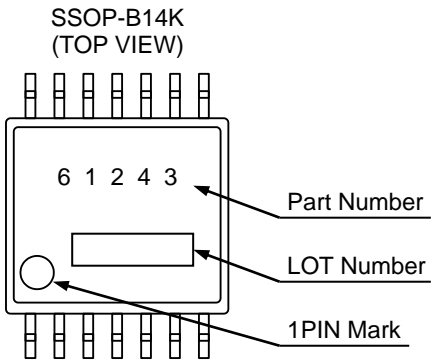

Physical Dimension, Tape and Reel Information

Package Name	SSOP-B14K
--------------	-----------

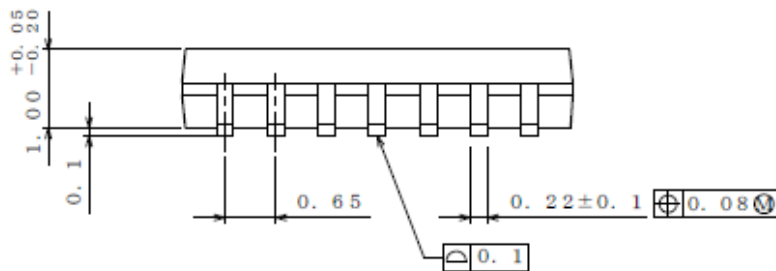
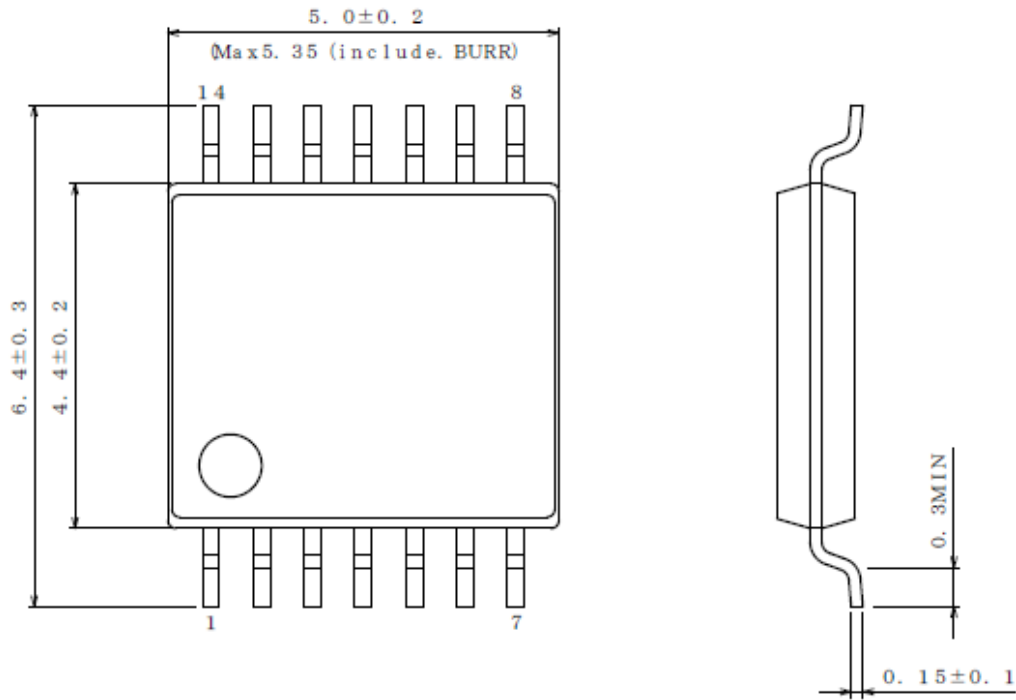

(UNIT : mm)  
 PKG : SSOP-B14K  
 Drawing No. EX001-0104

< Tape and Reel Information >

Tape	Embossed carrier tape
Quantity	2500pcs
Direction of feed	E2 The direction is the pin 1 of product is at the upper left when you hold reel on the left hand and you pull out the tape on the right hand

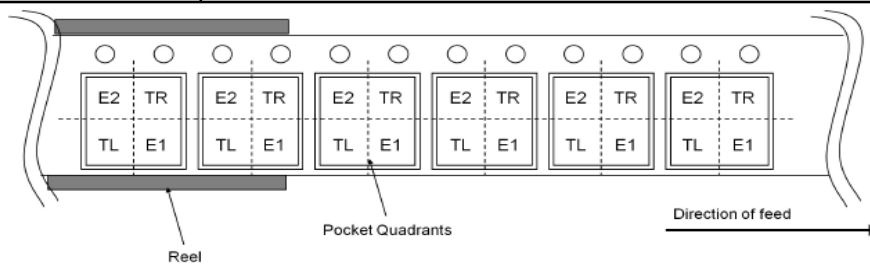

# Notice

## Precaution on using ROHM Products

- Our Products are designed and manufactured for application in ordinary electronic equipment (such as AV equipment, OA equipment, telecommunication equipment, home electronic appliances, amusement equipment, etc.). If you intend to use our Products in devices requiring extremely high reliability (such as medical equipment <sup>(Note 1)</sup>, transport equipment, traffic equipment, aircraft/spacecraft, nuclear power controllers, fuel controllers, car equipment including car accessories, safety devices, etc.) and whose malfunction or failure may cause loss of human life, bodily injury or serious damage to property ("Specific Applications"), please consult with the ROHM sales representative in advance. Unless otherwise agreed in writing by ROHM in advance, ROHM shall not be in any way responsible or liable for any damages, expenses or losses incurred by you or third parties arising from the use of any ROHM's Products for Specific Applications.

(Note1) Medical Equipment Classification of the Specific Applications

JAPAN	USA	EU	CHINA
CLASS III	CLASS III	CLASS II b	CLASS III
CLASS IV		CLASS III	

- ROHM designs and manufactures its Products subject to strict quality control system. However, semiconductor products can fail or malfunction at a certain rate. Please be sure to implement, at your own responsibilities, adequate safety measures including but not limited to fail-safe design against the physical injury, damage to any property, which a failure or malfunction of our Products may cause. The following are examples of safety measures:
  - Installation of protection circuits or other protective devices to improve system safety
  - Installation of redundant circuits to reduce the impact of single or multiple circuit failure
- Our Products are designed and manufactured for use under standard conditions and not under any special or extraordinary environments or conditions, as exemplified below. Accordingly, ROHM shall not be in any way responsible or liable for any damages, expenses or losses arising from the use of any ROHM's Products under any special or extraordinary environments or conditions. If you intend to use our Products under any special or extraordinary environments or conditions (as exemplified below), your independent verification and confirmation of product performance, reliability, etc. prior to use, must be necessary:
  - Use of our Products in any types of liquid, including water, oils, chemicals, and organic solvents
  - Use of our Products outdoors or in places where the Products are exposed to direct sunlight or dust
  - Use of our Products in places where the Products are exposed to sea wind or corrosive gases, including Cl<sub>2</sub>, H<sub>2</sub>S, NH<sub>3</sub>, SO<sub>2</sub>, and NO<sub>2</sub>
  - Use of our Products in places where the Products are exposed to static electricity or electromagnetic waves
  - Use of our Products in proximity to heat-producing components, plastic cords, or other flammable items
  - Sealing or coating our Products with resin or other coating materials
  - Use of our Products without cleaning residue of flux (Exclude cases where no-clean type fluxes is used. However, recommend sufficiently about the residue.) ; or Washing our Products by using water or water-soluble cleaning agents for cleaning residue after soldering
  - Use of the Products in places subject to dew condensation
- The Products are not subject to radiation-proof design.
- Please verify and confirm characteristics of the final or mounted products in using the Products.
- In particular, if a transient load (a large amount of load applied in a short period of time, such as pulse, is applied, confirmation of performance characteristics after on-board mounting is strongly recommended. Avoid applying power exceeding normal rated power; exceeding the power rating under steady-state loading condition may negatively affect product performance and reliability.
- De-rate Power Dissipation depending on ambient temperature. When used in sealed area, confirm that it is the use in the range that does not exceed the maximum junction temperature.
- Confirm that operation temperature is within the specified range described in the product specification.
- ROHM shall not be in any way responsible or liable for failure induced under deviant condition from what is defined in this document.

## Precaution for Mounting / Circuit board design

- When a highly active halogenous (chlorine, bromine, etc.) flux is used, the residue of flux may negatively affect product performance and reliability.
- In principle, the reflow soldering method must be used on a surface-mount products, the flow soldering method must be used on a through hole mount products. If the flow soldering method is preferred on a surface-mount products, please consult with the ROHM representative in advance.

For details, please refer to ROHM Mounting specification

### Precautions Regarding Application Examples and External Circuits

1. If change is made to the constant of an external circuit, please allow a sufficient margin considering variations of the characteristics of the Products and external components, including transient characteristics, as well as static characteristics.
2. You agree that application notes, reference designs, and associated data and information contained in this document are presented only as guidance for Products use. Therefore, in case you use such information, you are solely responsible for it and you must exercise your own independent verification and judgment in the use of such information contained in this document. ROHM shall not be in any way responsible or liable for any damages, expenses or losses incurred by you or third parties arising from the use of such information.

### Precaution for Electrostatic

This Product is electrostatic sensitive product, which may be damaged due to electrostatic discharge. Please take proper caution in your manufacturing process and storage so that voltage exceeding the Products maximum rating will not be applied to Products. Please take special care under dry condition (e.g. Grounding of human body / equipment / solder iron, isolation from charged objects, setting of Ionizer, friction prevention and temperature / humidity control).

### Precaution for Storage / Transportation

1. Product performance and soldered connections may deteriorate if the Products are stored in the places where:
  - [a] the Products are exposed to sea winds or corrosive gases, including Cl<sub>2</sub>, H<sub>2</sub>S, NH<sub>3</sub>, SO<sub>2</sub>, and NO<sub>2</sub>
  - [b] the temperature or humidity exceeds those recommended by ROHM
  - [c] the Products are exposed to direct sunshine or condensation
  - [d] the Products are exposed to high Electrostatic
2. Even under ROHM recommended storage condition, solderability of products out of recommended storage time period may be degraded. It is strongly recommended to confirm solderability before using Products of which storage time is exceeding the recommended storage time period.
3. Store / transport cartons in the correct direction, which is indicated on a carton with a symbol. Otherwise bent leads may occur due to excessive stress applied when dropping of a carton.
4. Use Products within the specified time after opening a humidity barrier bag. Baking is required before using Products of which storage time is exceeding the recommended storage time period.

### Precaution for Product Label

A two-dimensional barcode printed on ROHM Products label is for ROHM's internal use only.

### Precaution for Disposition

When disposing Products please dispose them properly using an authorized industry waste company.

### Precaution for Foreign Exchange and Foreign Trade act

Since concerned goods might be fallen under listed items of export control prescribed by Foreign exchange and Foreign trade act, please consult with ROHM in case of export.

### Precaution Regarding Intellectual Property Rights

1. All information and data including but not limited to application example contained in this document is for reference only. ROHM does not warrant that foregoing information or data will not infringe any intellectual property rights or any other rights of any third party regarding such information or data.
2. ROHM shall not have any obligations where the claims, actions or demands arising from the combination of the Products with other articles such as components, circuits, systems or external equipment (including software).
3. No license, expressly or implied, is granted hereby under any intellectual property rights or other rights of ROHM or any third parties with respect to the Products or the information contained in this document. Provided, however, that ROHM will not assert its intellectual property rights or other rights against you or your customers to the extent necessary to manufacture or sell products containing the Products, subject to the terms and conditions herein.

### Other Precaution

1. This document may not be reprinted or reproduced, in whole or in part, without prior written consent of ROHM.
2. The Products may not be disassembled, converted, modified, reproduced or otherwise changed without prior written consent of ROHM.
3. In no event shall you use in any way whatsoever the Products and the related technical information contained in the Products or this document for any military purposes, including but not limited to, the development of mass-destruction weapons.
4. The proper names of companies or products described in this document are trademarks or registered trademarks of ROHM, its affiliated companies or third parties.

**General Precaution**

1. Before you use our Products, you are requested to carefully read this document and fully understand its contents. ROHM shall not be in any way responsible or liable for failure, malfunction or accident arising from the use of any ROHM's Products against warning, caution or note contained in this document.
2. All information contained in this document is current as of the issuing date and subject to change without any prior notice. Before purchasing or using ROHM's Products, please confirm the latest information with a ROHM sales representative.
3. The information contained in this document is provided on an "as is" basis and ROHM does not warrant that all information contained in this document is accurate and/or error-free. ROHM shall not be in any way responsible or liable for any damages, expenses or losses incurred by you or third parties resulting from inaccuracy or errors of or concerning such information.

## Looking for pricing, stock, or lifecycle information?

Click below to explore more details on WIN SOURCE:

-  [View BD61243FV-GE2 on WIN SOURCE](#)
-  [Rohm Semiconductor Information](#)

## Optimize Your Supply Chain with WIN SOURCE Solutions

-  Global Sourcing Solution
-  Obsolete Management
-  Cost Control Management
-  Shortage Management
-  Alternative Solution
-  Excess Inventory Management