



**THE DATASHEET OF  
BD22621G-MTR**



1 Channel Compact High Side Switch ICs

# 0.3A Current Limit High Side Switch ICs

## BD22621G-M

### General Description

BD22621G-M is a low on-resistance N-channel MOSFET high-side power switch, optimized for Universal Serial Bus (USB) applications. BD22621G-M is equipped with the function of over-current detection, thermal shutdown, under-voltage lockout and soft-start.

### Key Specifications

■ Input Voltage Range:	2.7V to 5.5V
■ ON-Resistance:	120mΩ(Typ)
■ Over-Current Threshold:	0.3A(Typ)
■ Standby Current:	0.01μA (Typ)
■ Operating Temperature Range:	-40°C to +105°C

### Features

- AEC-Q100 Qualified<sup>(Note1)</sup>
- Over Current Threshold: 0.3A
- Built-in Low ON-Resistance (Typ 120mΩ)  
N-Channel MOSFET
- Reverse Current Protection when  
Power Switch Off
- Thermal Shutdown
- Under-Voltage Lockout
- Open-Drain Error Flag Output
- Output Discharge Function
- Soft Start Circuit
- Control Input Logic : Active-High

(Note1: Grade2)

### Package

W(Typ) x D(Typ) x H(Max)

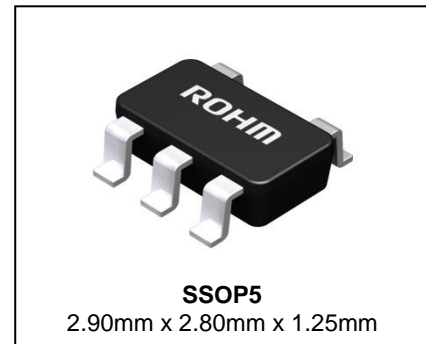

### Applications

Car accessory, Industrial applications

### Typical Application Circuit

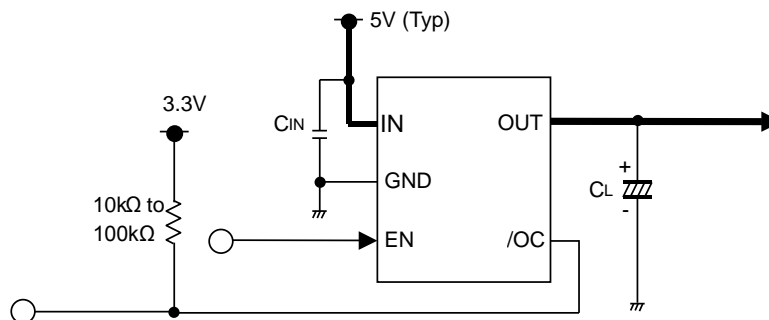

### Lineup

Over-Current Threshold			Control Input Logic	Package		Orderable Part Number
Min	Typ	Max				
0.18A	0.3A	0.42A	High	SSOP5	Reel of 3000	BD22621G-MTR

Block Diagram

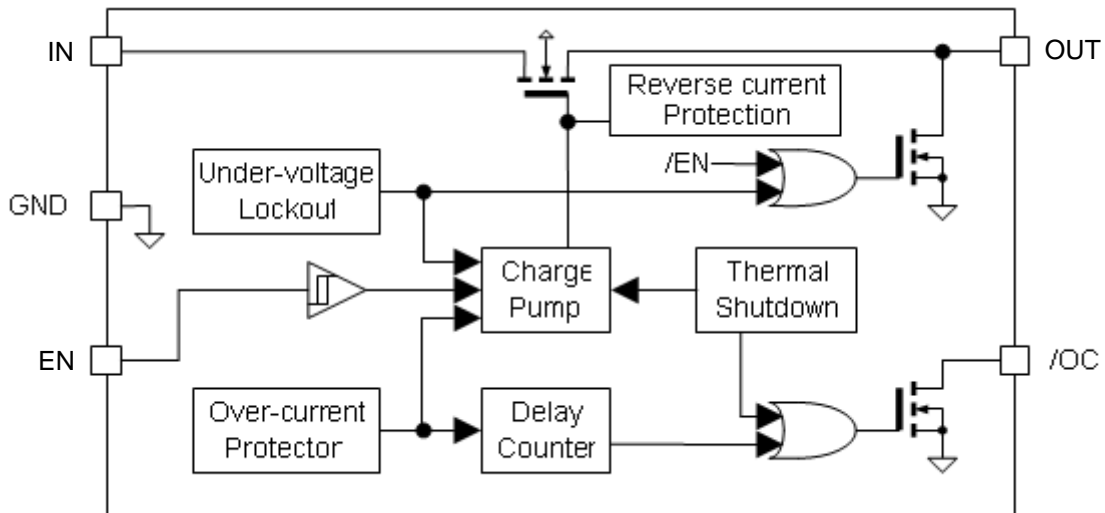

Pin Configurations

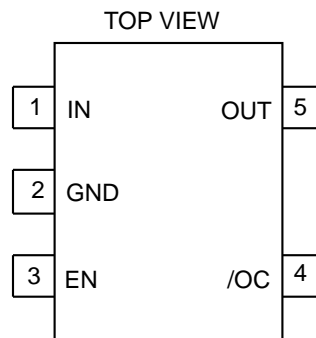

Pin Description

Pin No.	Symbol	I/O	Function
1	IN	-	Switch input and supply voltage for the IC.
2	GND	-	Ground.
3	EN	I	Enable input. EN: High level input turns on the switch.
4	/OC	O	Over-current detection pin. Low level output during over-current or over-temperature condition. Open-drain fault flag output.
5	OUT	O	Switch output.

**Absolute Maximum Ratings**

Parameter	Symbol	Rating	Unit
IN Supply Voltage	V <sub>IN</sub>	-0.3 to +6.0	V
EN Input Voltage	V <sub>EN</sub>	-0.3 to +6.0	V
/OC Voltage	V <sub>/OC</sub>	-0.3 to +6.0	V
/OC Sink Current	I <sub>/OC</sub>	5	mA
OUT Voltage	V <sub>OUT</sub>	-0.3 to +6.0	V
Storage Temperature	T <sub>stg</sub>	-55 to +150	°C

**Caution:** Operating the IC over the absolute maximum ratings may damage the IC. The damage can either be a short circuit between pins or an open circuit between pins and the internal circuitry. Therefore, it is important to consider circuit protection measures, such as adding a fuse, in case the IC is operated over the absolute maximum ratings.

**Thermal Resistance** <sup>(Note1)</sup>

Parameter	Symbol	Thermal Resistance (Typ)		Unit
		1s <sup>(Note3)</sup>	2s2p <sup>(Note4)</sup>	
<b>SSOP5</b>				
Junction to Ambient	θ <sub>JA</sub>	376.5	185.4	°C/W
Junction to Top Characterization Parameter <sup>(Note2)</sup>	Ψ <sub>JT</sub>	40	30	°C/W

<sup>(Note1)</sup>Based on JESD51-2A(Still-Air)

<sup>(Note2)</sup>The thermal characterization parameter to report the difference between junction temperature and the temperature at the top center of the outside surface of the component package.

<sup>(Note3)</sup>Using a PCB board based on JESD51-3.

Layer Number of Measurement Board	Material	Board Size
Single	FR-4	114.3mm x 76.2mm x 1.57mm

Top	
Copper Pattern	Thickness
Footprints and Traces	70µm

<sup>(Note4)</sup>Using a PCB board based on JESD51-7.

Layer Number of Measurement Board	Material	Board Size
4 Layers	FR-4	114.3mm x 76.2mm x 1.6mm

Top		2 Internal Layers		Bottom	
Copper Pattern	Thickness	Copper Pattern	Thickness	Copper Pattern	Thickness
Footprints and Traces	70µm	74.2mm <sup>2</sup> (Square)	35µm	74.2mm <sup>2</sup> (Square)	70µm

**Recommended Operating Conditions (T<sub>j</sub>= -40°C to +105°C)**

Parameter	Symbol	Rating			Unit
		Min	Typ	Max	
IN Operating Voltage	V <sub>IN</sub>	2.7	5.0	5.5	V
Continuous Current	I <sub>OMAX</sub>	-	-	200	mA

**Electrical Characteristics**

( $V_{IN} = 5V$ ,  $T_j = -40$  to  $+105^\circ C$ , unless otherwise specified.)

**DC Characteristics**

Parameter	Symbol	Limit			Unit	Conditions
		Min	Typ	Max		
Operating Current	$I_{DD}$	-	135	200	$\mu A$	$V_{EN} = 5V$ $V_{OUT} = open$
Standby Current	$I_{STB}$	-	0.01	5	$\mu A$	$V_{EN} = 0V$ $V_{OUT} = open$
EN Input Voltage	$V_{ENH}$	2.0	-	-	V	High Input, $V_{IN} = 3.3$ to $5V$
	$V_{ENL}$	-	-	0.8	V	Low Input, $V_{IN} = 5V$
	$V_{ENL}$	-	-	0.6	V	Low Input, $V_{IN} = 3.3V$
EN Input Leakage	$I_{EN}$	-1	+0.01	+1	$\mu A$	$V_{EN} = 0V$ or $5V$
ON-Resistance	$R_{ON}$	-	120	165	$m\Omega$	$V_{IN} = 5V$ , $I_{OUT} = 100mA$ $T_j = 25^\circ C$
		-	120	250		$V_{IN} = 5V$ , $I_{OUT} = 100mA$ $T_j = -40^\circ C$ to $+105^\circ C$
		-	140	190		$V_{IN} = 3.3V$ , $I_{OUT} = 100mA$ $T_j = 25^\circ C$
		-	140	270		$V_{IN} = 3.3V$ , $I_{OUT} = 100mA$ $T_j = -40^\circ C$ to $+105^\circ C$
Reverse Leak Current	$I_{REV}$	-	-	1.0	$\mu A$	$V_{OUT} = 5.0V$ , $V_{IN} = 0V$
Over-Current Threshold	$I_{TH}$	180	300	420	mA	$V_{IN} = 5V$
		170	290	410		$V_{IN} = 3.3V$
Short Circuit Output Current	$I_{SC}$	90	200	325	mA	$V_{IN} = 3.3$ to $5V$ , $V_{OUT} = 0V$ , RMS
Output Discharge Resistance	$R_{DISC}$	15	60	165	$\Omega$	$I_{DISC} = 1mA$
/OC Output Low Voltage	$V_{/OC}$	-	-	0.4	V	$I_{/OC} = 0.5mA$
UVLO Threshold	$V_{TUVH}$	2.1	2.3	2.5	V	$V_{IN}$ Increasing
	$V_{TUVL}$	2.0	2.2	2.4	V	$V_{IN}$ Decreasing

**AC Characteristics**

Parameter	Symbol	Limit			Unit	Conditions
		Min	Typ	Max		
Output Rise Time	$t_{ON1}$	-	1	6	ms	$R_L = 500\Omega$
Output Turn ON Time	$t_{ON2}$	-	1.5	10	ms	
Output Fall Time	$t_{OFF1}$	-	1	20	$\mu s$	
Output Turn OFF Time	$t_{OFF2}$	-	3	40	$\mu s$	
/OC Delay Time	$t_{/OC}$	9	15	21	ms	

Measurement Circuit

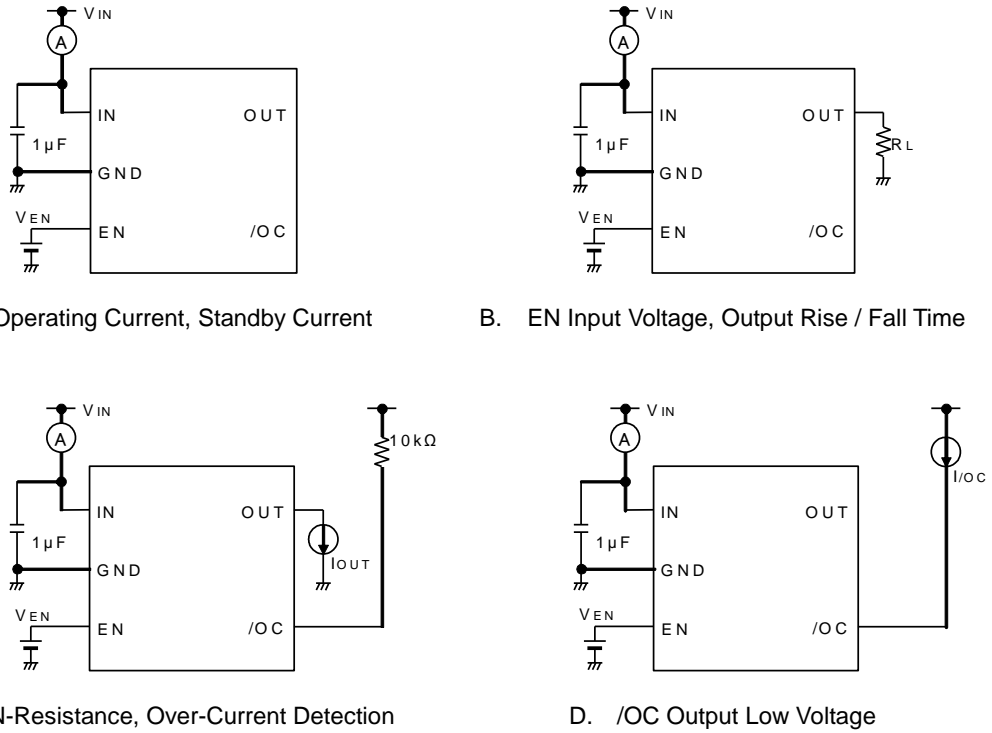

Figure 1. Measurement Circuit

Timing Diagram

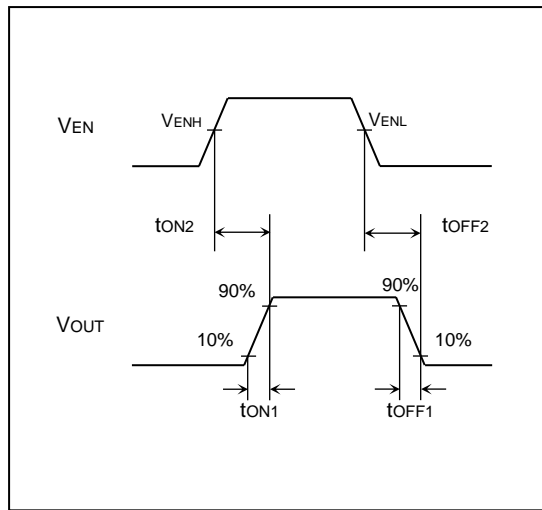

Figure 2. Output Rise / Fall Time

Typical Performance Curves

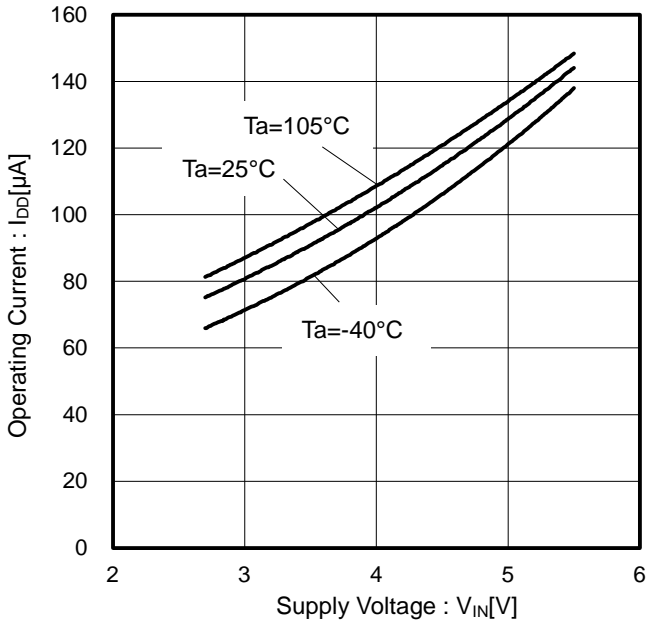

Figure 3. Operating Current vs Supply Voltage (EN Enable)

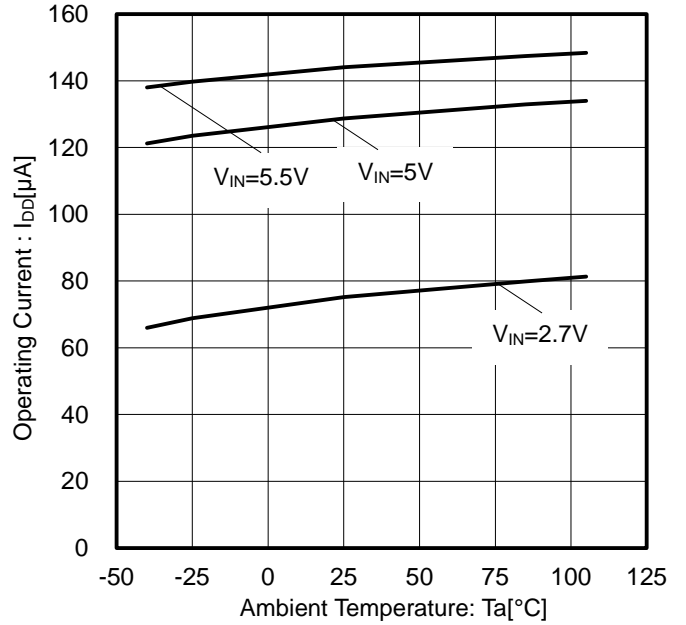

Figure 4. Operating Current vs Ambient Temperature (EN Enable)

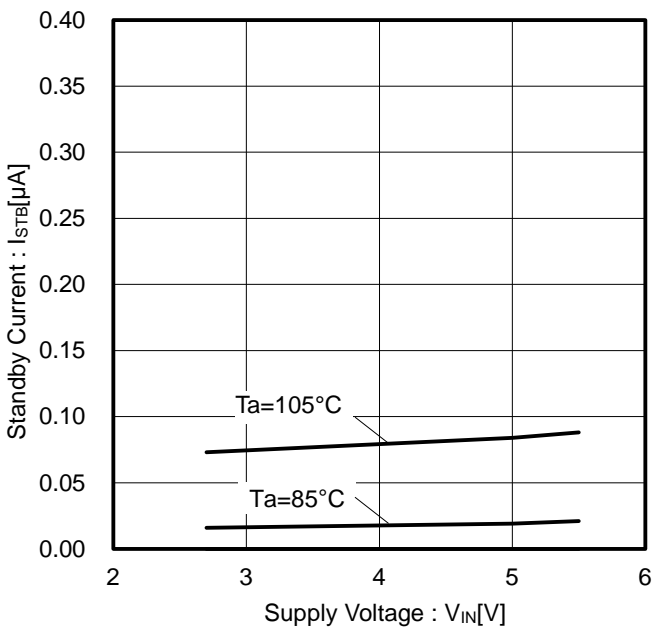

Figure 5. Standby Current vs Supply Voltage (EN Disable)

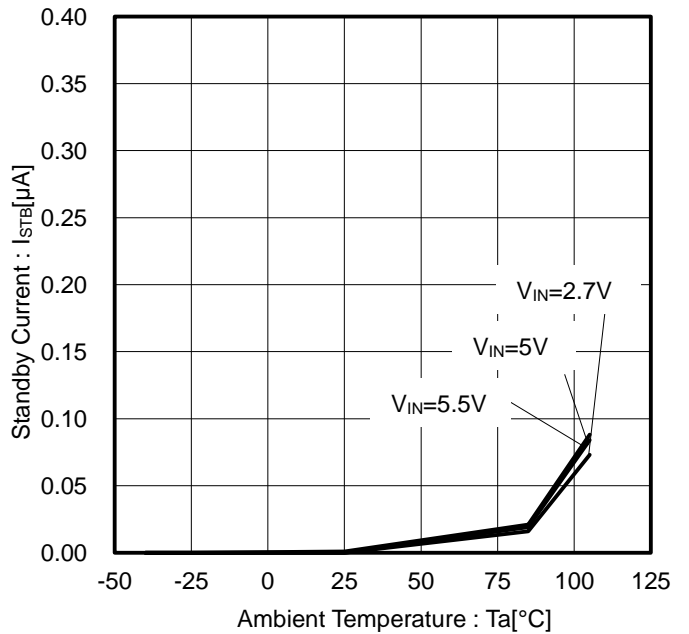

Figure 6. Standby Current vs Ambient Temperature (EN Disable)

▼  
Typical Performance Curves

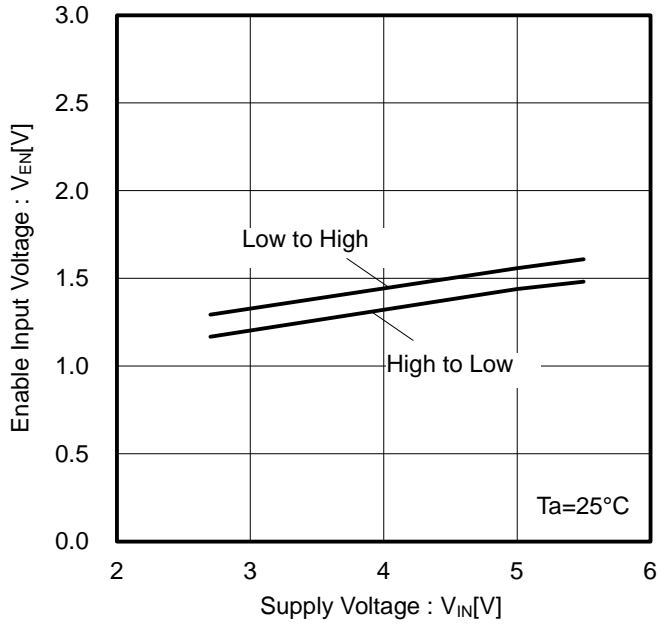

Figure 7. EN Input Voltage vs Supply Voltage ( $V_{ENH}$ ,  $V_{ENL}$ )

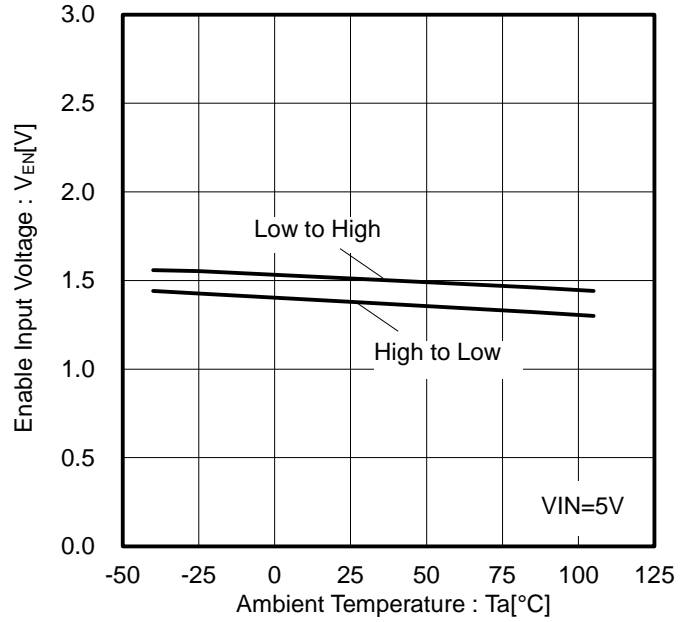

Figure 8. EN Input Voltage vs Ambient Temperature ( $V_{ENH}$ ,  $V_{ENL}$ )

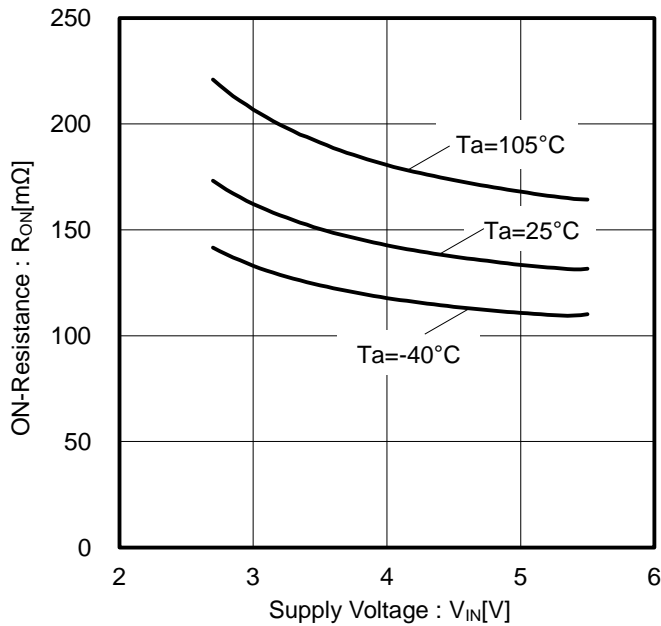

Figure 9. ON-Resistance vs Supply Voltage

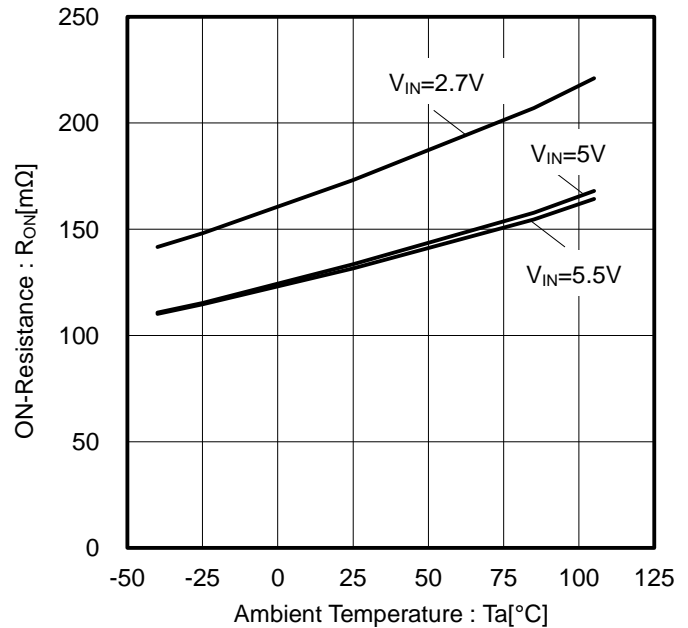

Figure 10. ON-Resistance vs Ambient Temperature

Typical Performance Curves - continued

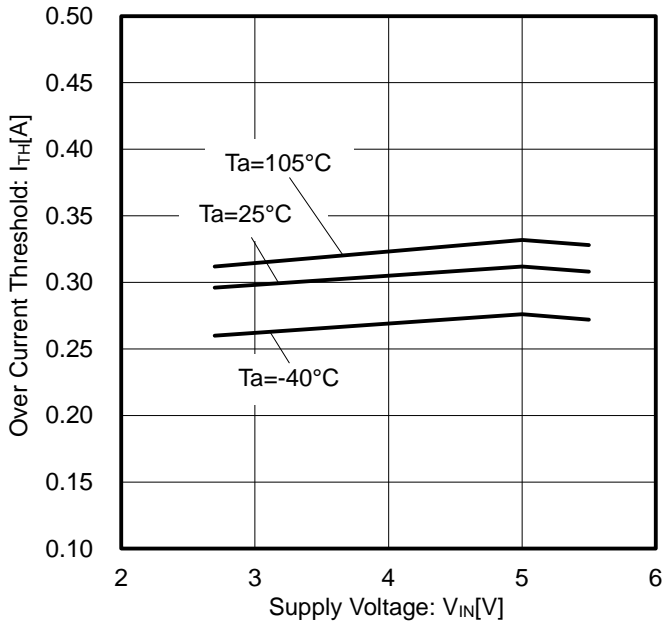

Figure 11. Over-Current Threshold vs Supply Voltage

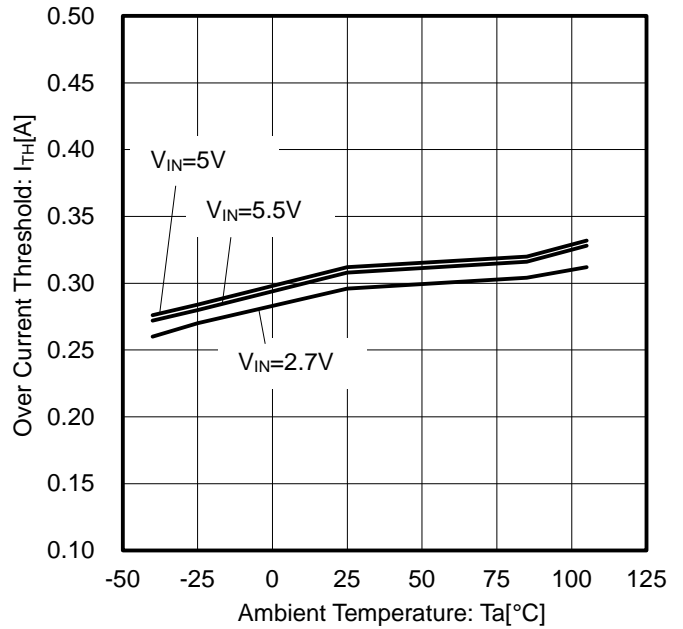

Figure 12. Over-Current Threshold vs Ambient Temperature

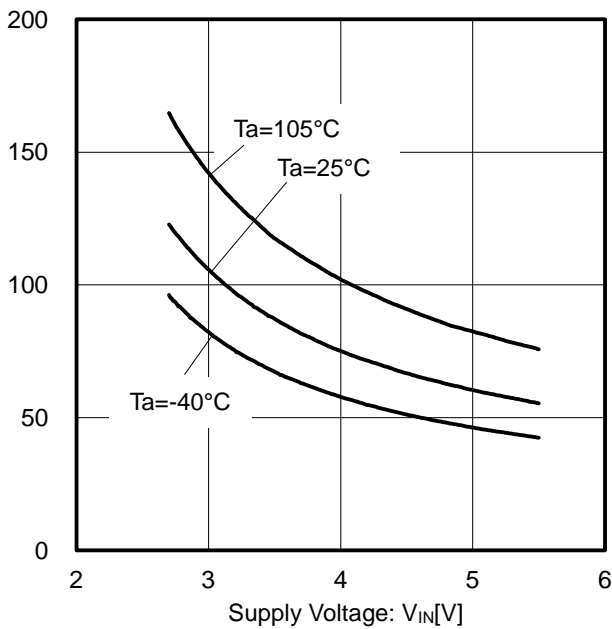

Figure 13. Output Discharge Resistance vs Supply Voltage

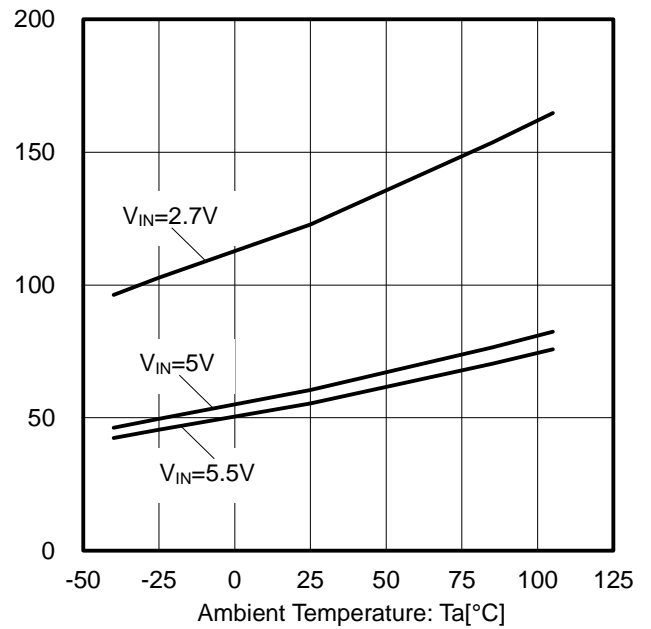

Figure 14. Output Discharge Resistance vs Ambient Temperature

Typical Performance Curves - continued

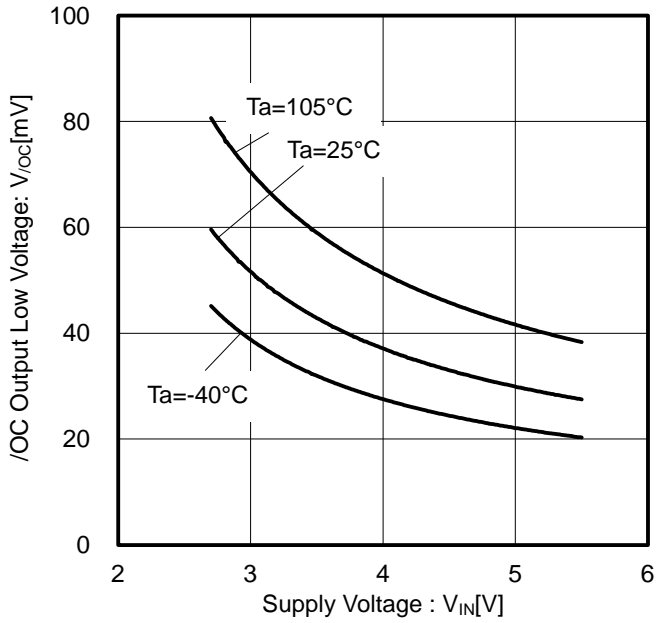

Figure 15. /OC Output Low Voltage vs Supply Voltage

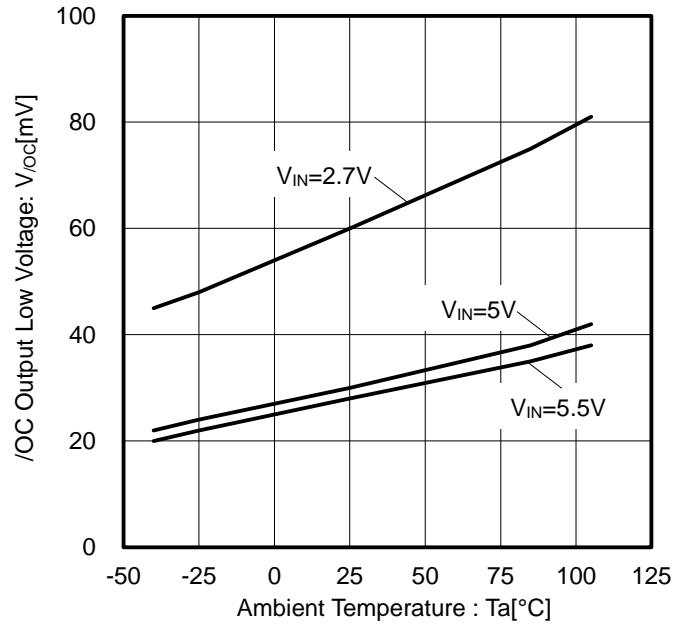

Figure 16. /OC Output Low Voltage vs Ambient Temperature

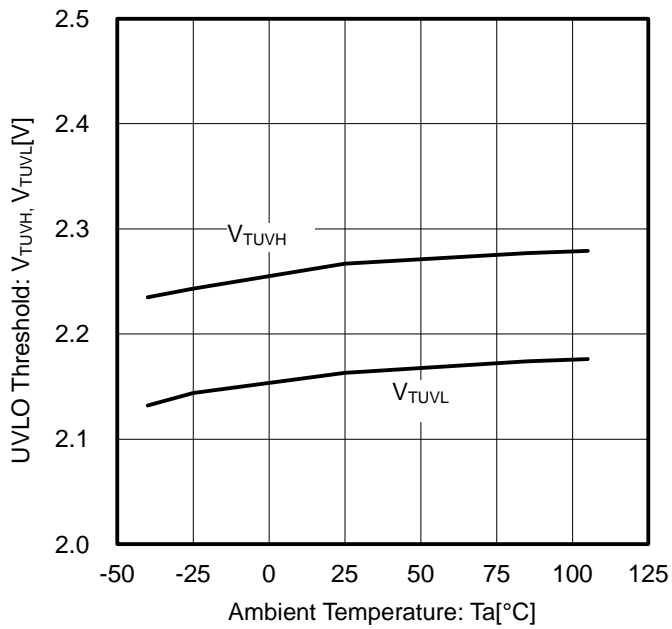

Figure 17. UVLO Threshold Voltage vs Ambient Temperature

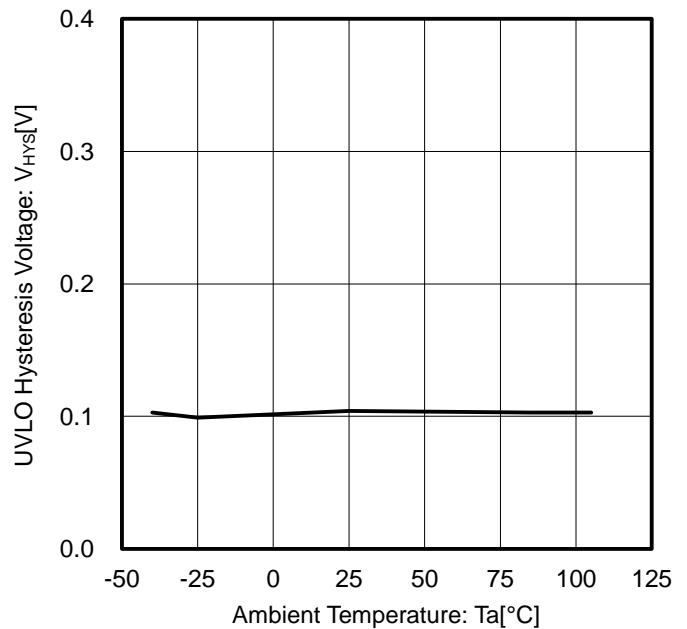

Figure 18. UVLO Hysteresis Voltage vs Ambient Temperature

Typical Performance Curves - continued

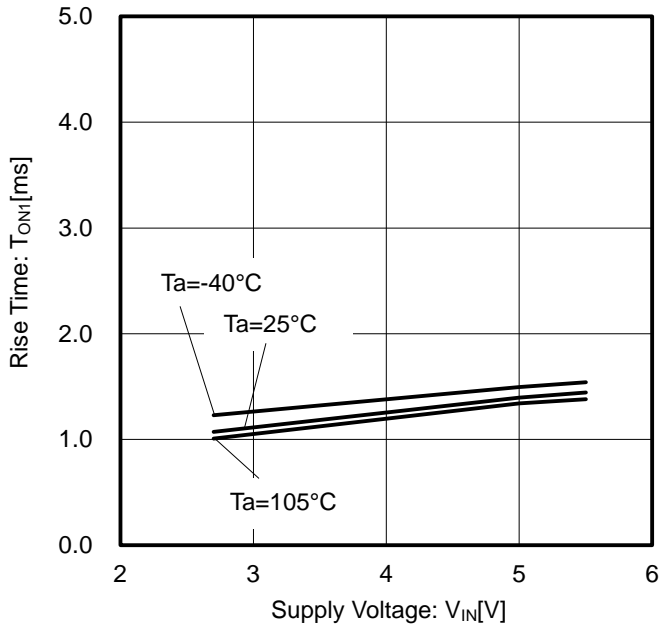

Figure 19. Output Rise Time vs Supply Voltage

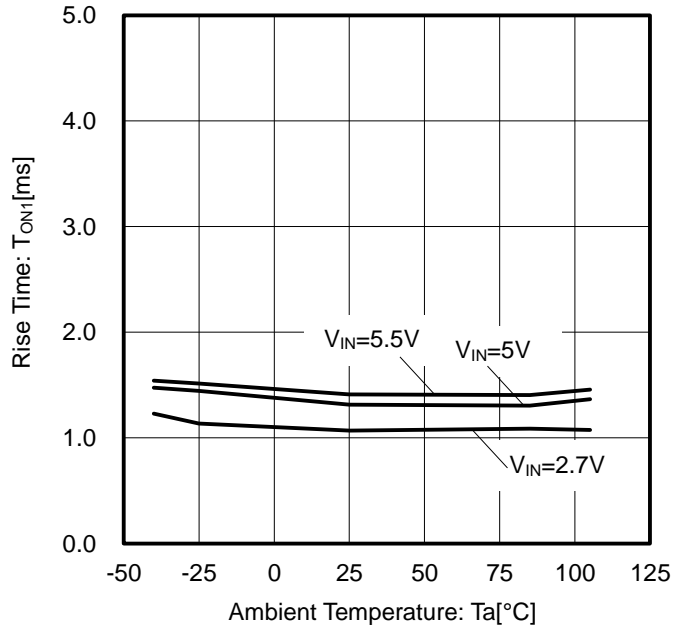

Figure 20. Output Rise Time vs Ambient Temperature

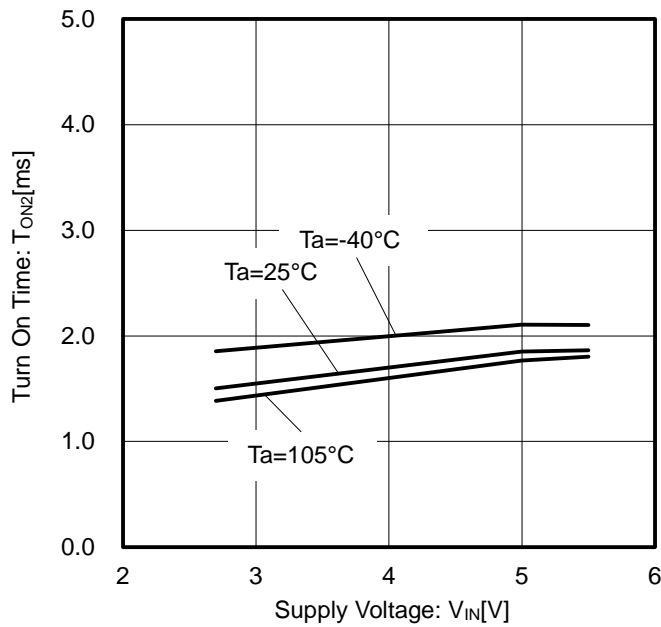

Figure 21. Output Turn-On Time vs Supply Voltage

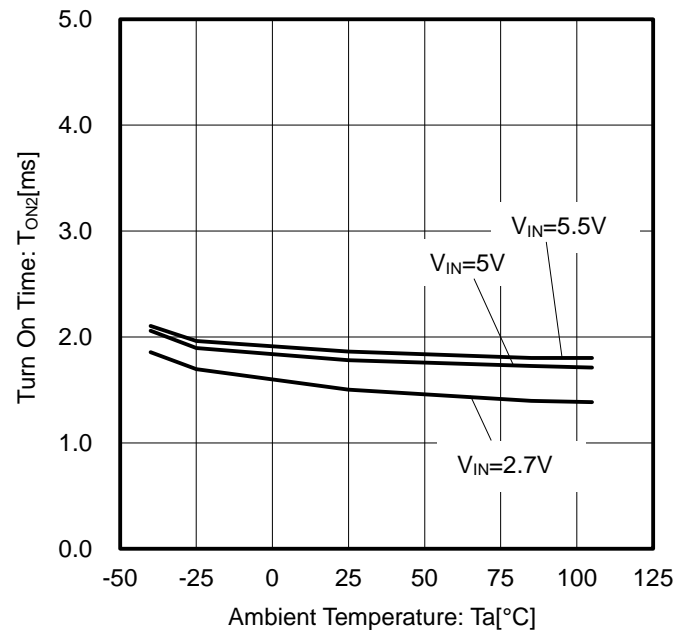

Figure 22. Output Turn-On Time vs Ambient Temperature

Typical Performance Curves - continued

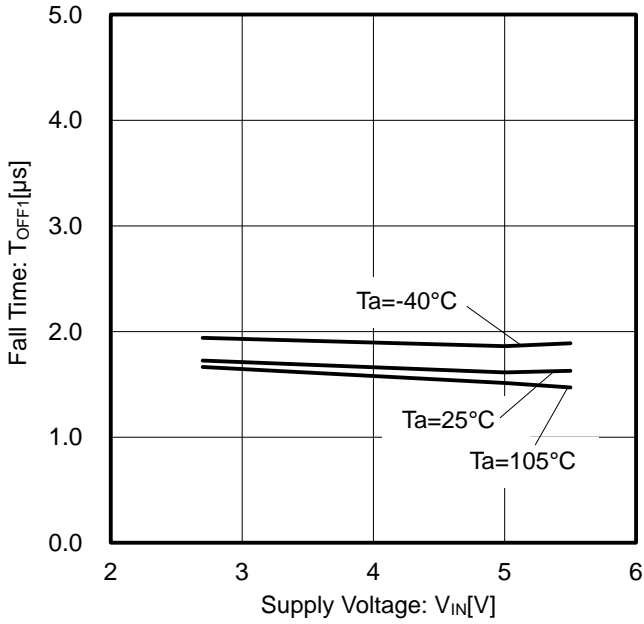

Figure 23. Output Fall Time vs Supply Voltage

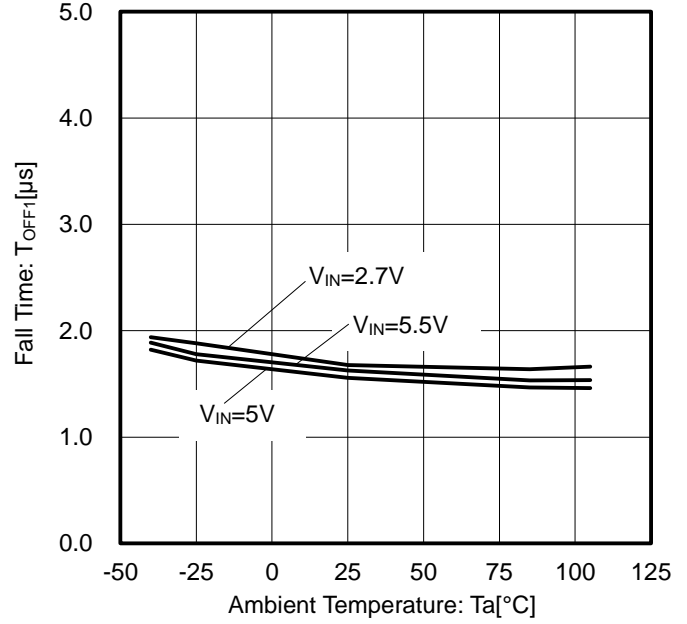

Figure 24. Output Fall Time vs Ambient Temperature

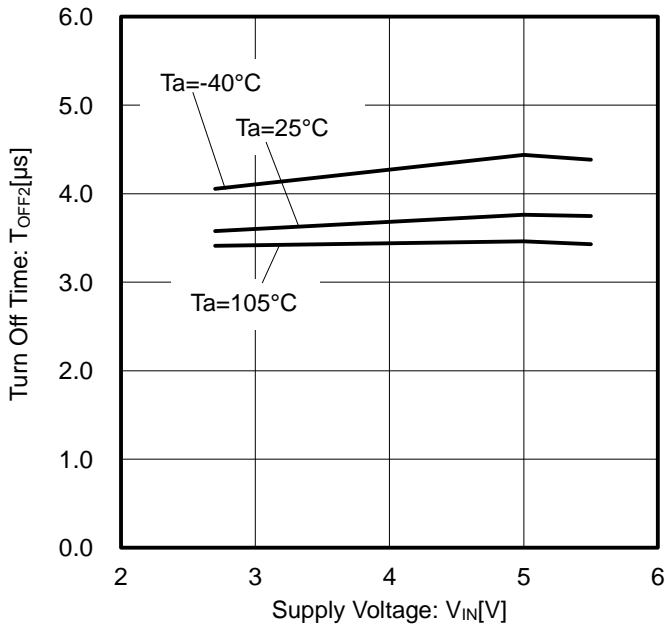

Figure 25. Output Turn-Off Time vs Supply Voltage

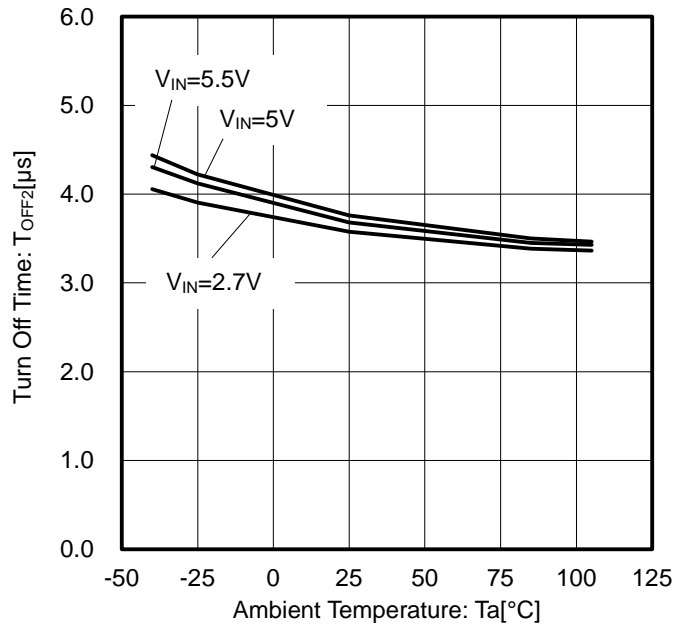

Figure 26. Output Turn-Off Time vs Ambient Temperature

Typical Performance Curves - continued

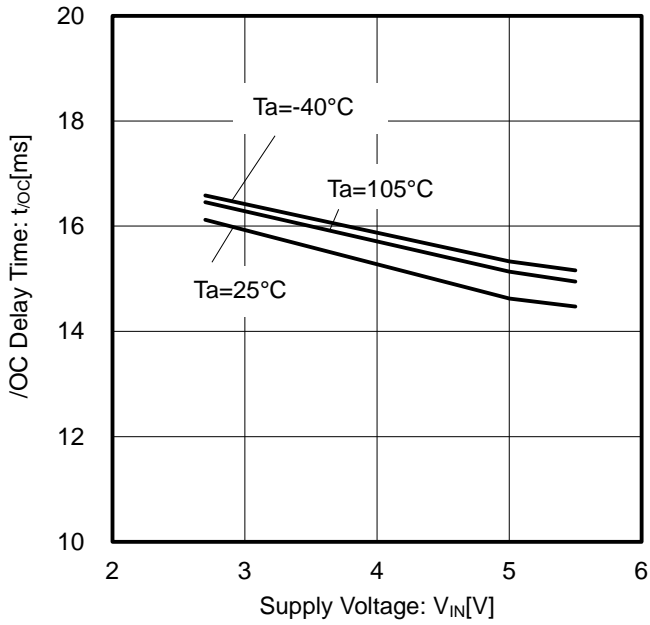

Figure 27. /OC Delay Time vs Supply Voltage

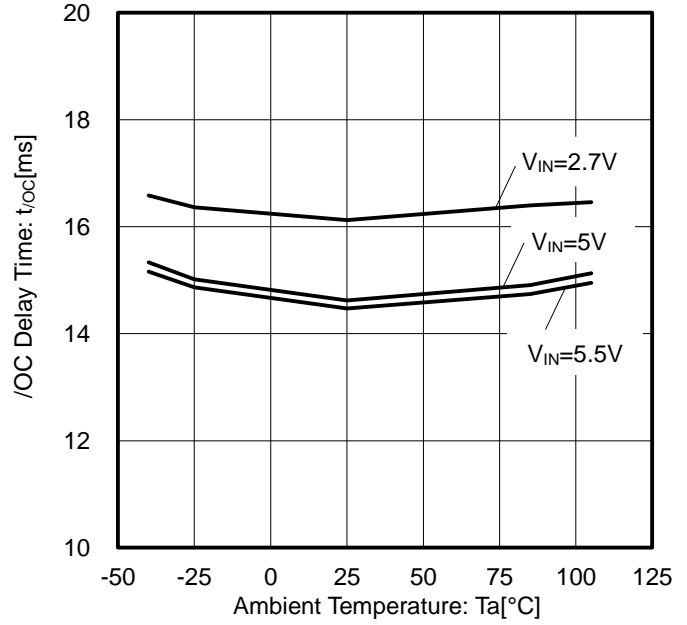

Figure 28. /OC Delay Time vs Ambient Temperature

Typical Wave Forms

(Ta=25°C, unless otherwise specified)

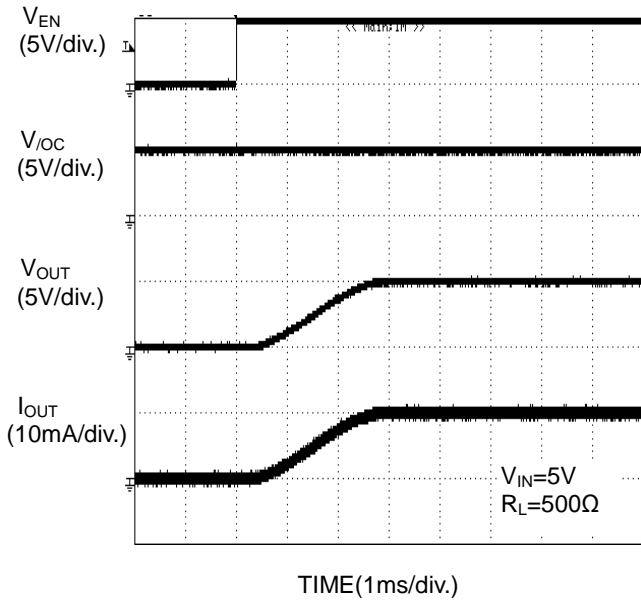

Figure 29. Output Rise Characteristic

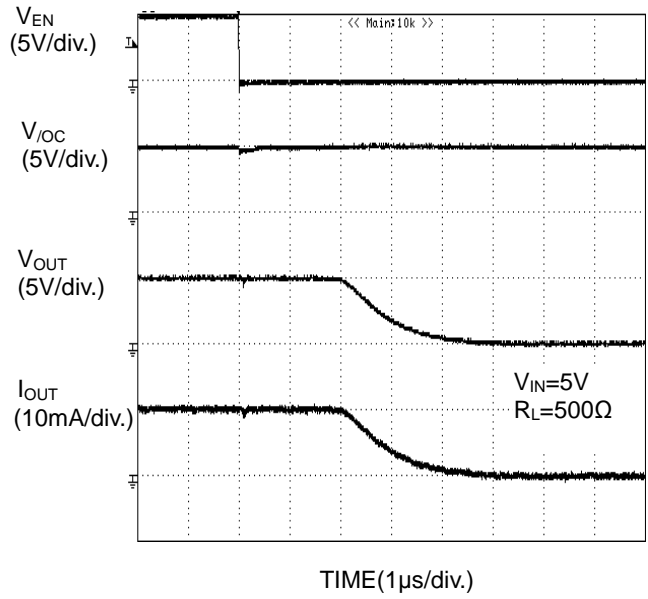

Figure 30. Output Fall Characteristic

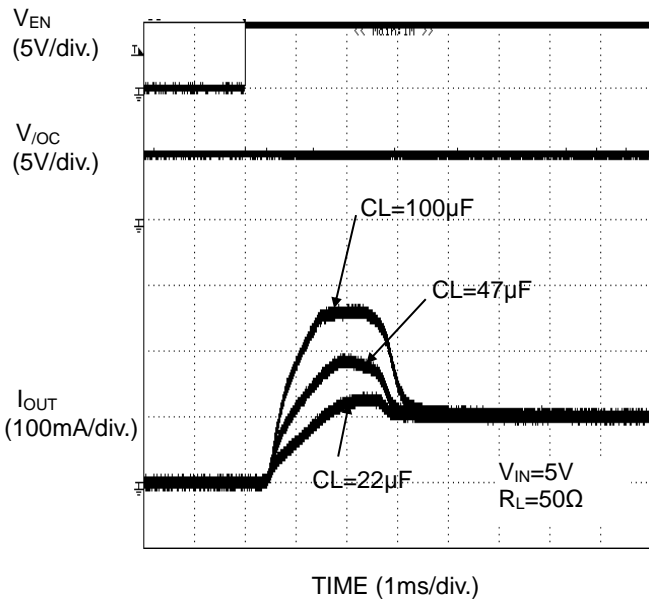

Figure 31. Inrush Current Response

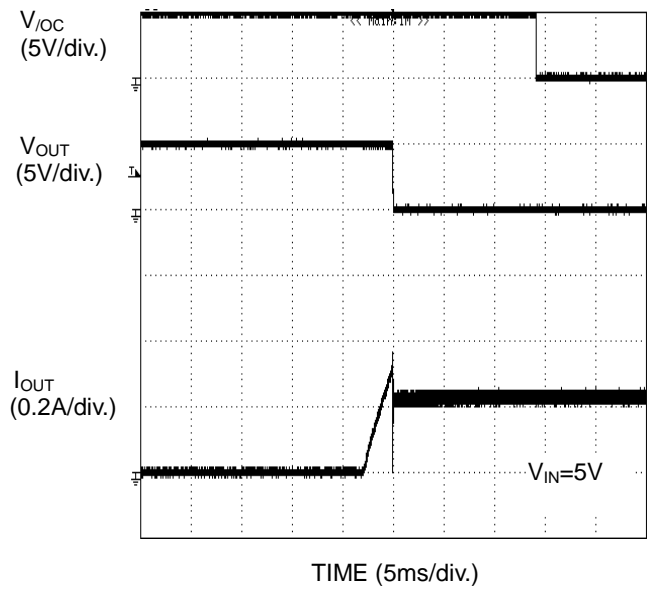
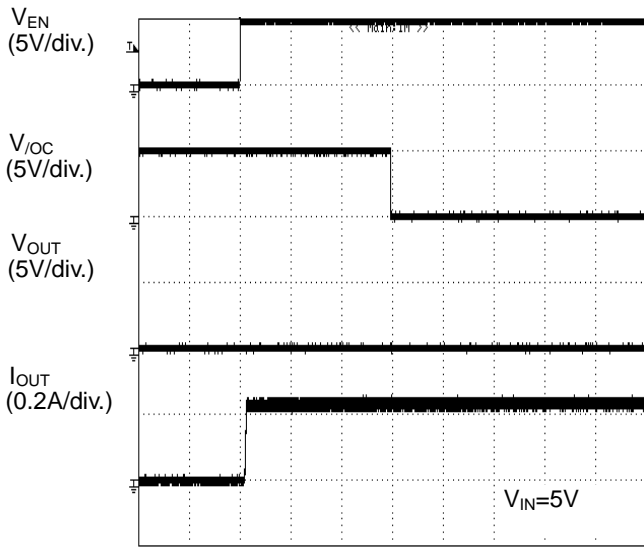

Figure 32. Over-Current Response

Typical Wave Forms – continued

(Ta=25°C, unless otherwise specified)



TIME (5ms/div.)  
 Figure 33. Over-Current Response  
 Enable to Short Circuit

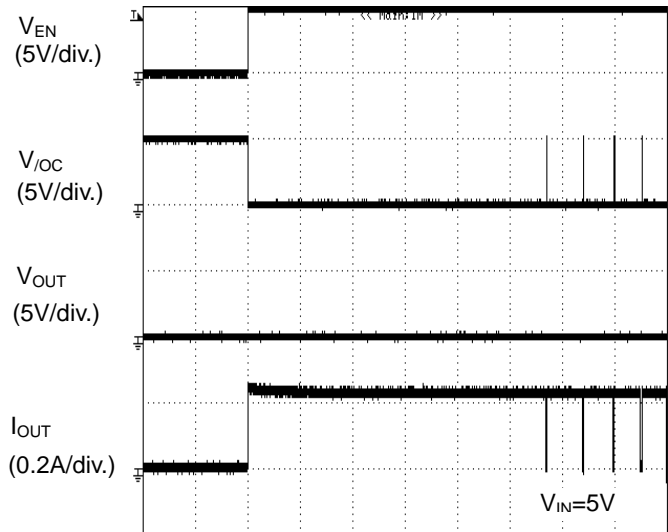

TIME (2s/div.)  
 Figure 34. Over-Current Response  
 Enable to Short Circuit

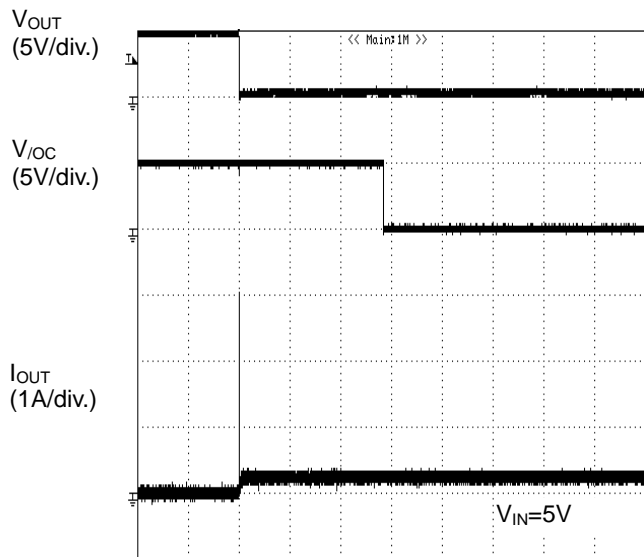

TIME (5ms/div.)  
 Figure 35. Over-Current Response  
 1Ω Load Connected to V<sub>OUT</sub>

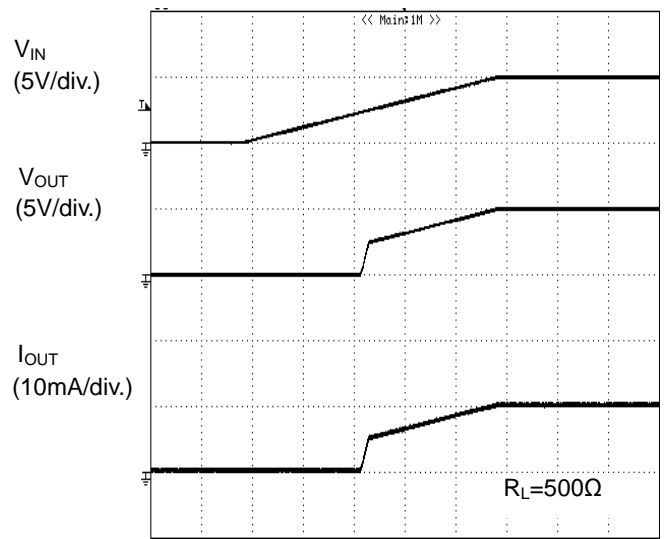

TIME (10ms/div.)  
 Figure 36. UVLO Response when  
 Increasing V<sub>IN</sub>

Typical Wave Forms – continued

(Ta=25°C, unless otherwise specified)

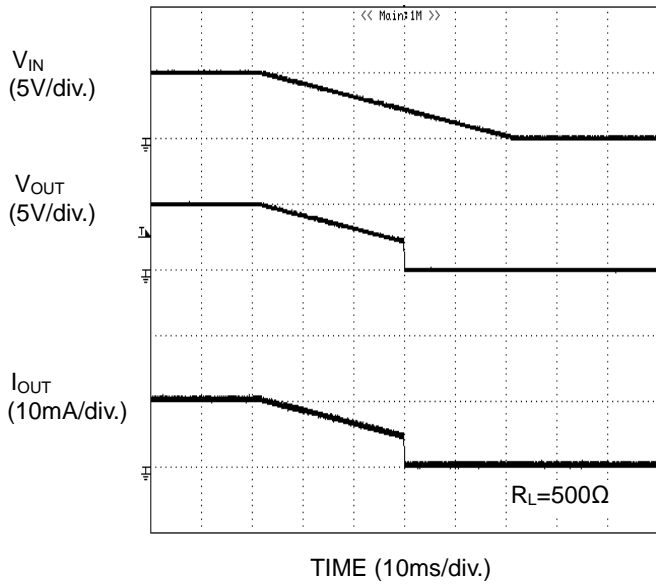
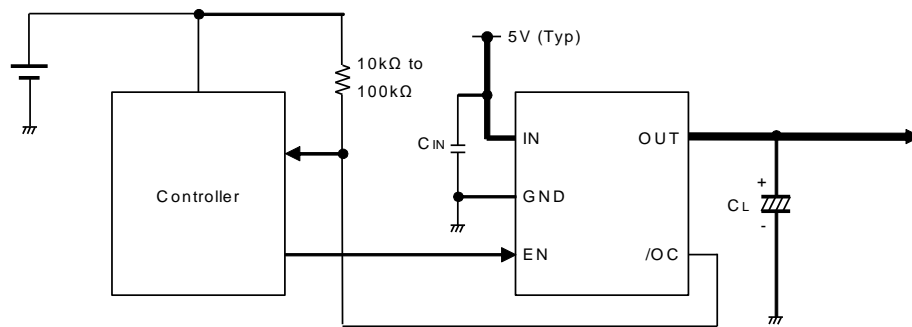

Figure 37. UVLO Response when Decreasing  $V_{IN}$

## Typical Application Circuit



## Application Information

When excessive current flows due to output short-circuit, ringing occurs because of the inductance between power source line and the IC. IN pin functions as both the power supply of the internal circuit of the IC and input of power switch. Therefore, ringing of power line may cause adverse effects on IC operations. In order to avoid this, it is recommended to connect a low ESR bypass capacitor (1μF or higher) between IN and GND pin which should be placed as close to these pins as possible. Additionally, in order to decrease voltage fluctuations from power source line to IC, connect a low ESR capacitor in parallel with C<sub>IN</sub>. 10μF to 100μF or higher is effective.

Pull up /OC output using 10kΩ to 100kΩ resistor values.

The value of C<sub>L</sub> should be chosen to satisfy the intended application.

This system connection diagram does not guarantee operation as the intended application.

When using the circuit with changes to the external circuit values, make sure to leave an adequate margin for external components taking into consideration the DC and transient characteristics as well as the design tolerance of the IC.

## Functional Description

### 1. Switch Operation

IN pin and OUT pin are connected to the drain and the source of switch MOSFET respectively. The IN pin is also used as power source input to internal control circuit.

When the switch is turned ON from EN control input, the IN and OUT pins are connected by a 120mΩ (Typ) switch. In ON status, the switch is bidirectional. Therefore, when the potential of OUT pin is higher than that of IN pin, current flows from OUT to IN pin. On the other hand, when the switch is turned off, it is possible to prevent current from flowing reversely from OUT to IN pin since a parasitic diode between the drain and the source of switch MOSFET is not present.

### 2. Thermal Shutdown Circuit (TSD)

In the event of continuous over-current condition, the temperature of the IC would increase drastically. If the junction temperature goes beyond 165°C (Typ) due to over-current detection, thermal shutdown circuit operates and turns power switch off, and the IC outputs a fault flag (/OC). Then, when the junction temperature decreases lower than 145°C (Typ), the power switch is turned on and fault flag (/OC) is cancelled. This operation repeats, unless the cause of the increase of chip's temperature is removed or the output of power switch is turned OFF.

The thermal shutdown circuit operates when the switch is ON (EN signal is active).

### 3. Over-Current Detection (OCD)

The over-current detection circuit limits current (I<sub>sc</sub>) and outputs fault flag (/OC) when current flowing in each switch MOSFET exceeds a specified value. The over-current detection circuit works when the switch is on (EN signal is active). There are three types of response against over-current:

- (1) When the switch is turned on while the output is in short circuit status, the switch goes into current limit status immediately.
- (2) When the output short-circuits or high capacity load is connected while the switch is on, very large current flows until the over-current limit circuit reacts. When the current detection and limit circuit operates, current limitation is carried out.
- (3) When the output current increases gradually, current limitation would not operate unless the output current exceeds the over-current detection value. When it exceeds the detection value, current limitation is carried out.

4. Under-Voltage Lockout (UVLO)

UVLO circuit prevents the switch from turning on until the  $V_{IN}$  exceeds 2.3V (Typ). If  $V_{IN}$  drops below 2.2V (Typ) while the switch is still ON, then UVLO shuts off the power switch. UVLO has a hysteresis of 100mV (Typ). Under-voltage lockout circuit operates when the switch is on (EN signal is active).

5. Fault Flag (/OC) Output

Fault flag output is an N-MOS open drain output. During detection of over-current and/or thermal shutdown, the output level will turn low. Over-current detection has delay filter. This delay filter prevents current detection flags from being sent during instantaneous events such as inrush current at switch on or during hot plug. If fault flag output is unused, /OC pin should be connected to open or ground line.

6. Output Discharge Function

When the switch is turned off by disabling control input or UVLO function, the  $60\Omega$ (Typ.) discharge circuit between OUT and GND turns on which discharges the electric charge of the capacitive load. However, if the voltage of IN declines rapidly, then the OUT pin becomes Hi-Z without UVLO function.

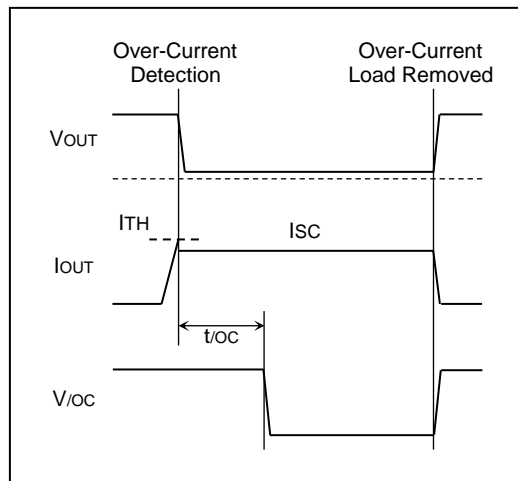

Figure 38. Over-Current Detection

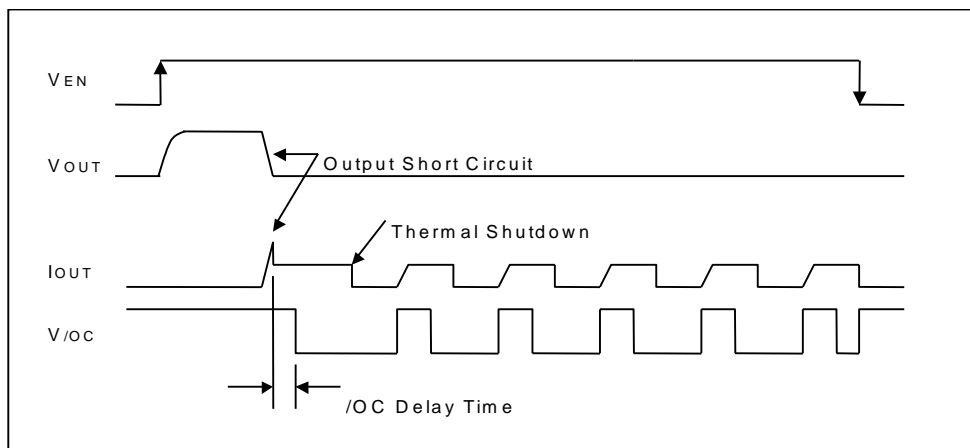

Figure 39. Over-Current Detection, Thermal Shutdown Timing

I/O Equivalent Circuit

Symbol	Pin No.	Equivalent Circuit
EN	3	
OUT	5	
/OC	4	

## Operational Notes

### 1. Reverse Connection of Power Supply

Connecting the power supply in reverse polarity can damage the IC. Take precautions against reverse polarity when connecting the power supply, such as mounting an external diode between the power supply and the IC's power supply pins.

### 2. Power Supply Lines

Design the PCB layout pattern to provide low impedance supply lines. Furthermore, connect a capacitor to ground at all power supply pins. Consider the effect of temperature and aging on the capacitance value when using electrolytic capacitors

### 3. Ground Voltage

Ensure that no pins are at a voltage below that of the ground pin at any time, even during transient condition.

### 4. Ground Wiring Pattern

When using both small-signal and large-current ground traces, the two ground traces should be routed separately but connected to a single ground at the reference point of the application board to avoid fluctuations in the small-signal ground caused by large currents. Also ensure that the ground traces of external components do not cause variations on the ground voltage. The ground lines must be as short and thick as possible to reduce line impedance.

### 5. Thermal Consideration

The amount of heat generated depends on the On-state resistance and Output current.

Should by any condition the maximum junction temperature  $T_{jmax} = 150\text{ }^{\circ}\text{C}$  rating be exceeded by the temperature increase of the chip, it may result in deterioration of the properties of the chip. The thermal impedance in this specification is based on recommended PCB and measurement condition by JEDEC standard. Verify the application and allow sufficient margins in the thermal design.

### 6. Recommended Operating Conditions

These conditions represent a range within which the expected characteristics of the IC can be approximately obtained. The electrical characteristics are guaranteed under the conditions of each parameter.

### 7. Inrush Current

When power is first supplied to the IC, it is possible that the internal logic may be unstable and inrush current may flow instantaneously due to the internal powering sequence and delays, especially if the IC has more than one power supply. Therefore, give special consideration to power coupling capacitance, power wiring, width of ground wiring, and routing of connections.

### 8. Operation Under Strong Electromagnetic Field

Operating the IC in the presence of a strong electromagnetic field may cause the IC to malfunction.

### 9. Testing on Application Boards

When testing the IC on an application board, connecting a capacitor directly to a low-impedance output pin may subject the IC to stress. Always discharge capacitors completely after each process or step. The IC's power supply should always be turned off completely before connecting or removing it from the test setup during the inspection process. To prevent damage from static discharge, ground the IC during assembly and use similar precautions during transport and storage.

### 10. Inter-pin Short and Mounting Errors

Ensure that the direction and position are correct when mounting the IC on the PCB. Incorrect mounting may result in damaging the IC. Avoid nearby pins being shorted to each other especially to ground, power supply and output pin. Inter-pin shorts could be due to many reasons such as metal particles, water droplets (in very humid environment) and unintentional solder bridge deposited in between pins during assembly to name a few.

### 11. Unused Input Pins

Input pins of an IC are often connected to the gate of a MOS transistor. The gate has extremely high impedance and extremely low capacitance. If left unconnected, the electric field from the outside can easily charge it. The small charge acquired in this way is enough to produce a significant effect on the conduction through the transistor and cause unexpected operation of the IC. So unless otherwise specified, unused input pins should be connected to the power supply or ground line.

Operational Notes – continued

12. Regarding the Input Pin of the IC

This monolithic IC contains P+ isolation and P substrate layers between adjacent elements in order to keep them isolated. P-N junctions are formed at the intersection of the P layers with the N layers of other elements, creating a parasitic diode or transistor. For example (refer to figure below):

When GND > Pin A and GND > Pin B, the P-N junction operates as a parasitic diode.  
 When GND > Pin B, the P-N junction operates as a parasitic transistor.

Parasitic diodes inevitably occur in the structure of the IC. The operation of parasitic diodes can result in mutual interference among circuits, operational faults, or physical damage. Therefore, conditions that cause these diodes to operate, such as applying a voltage lower than the GND voltage to an input pin (and thus to the P substrate) should be avoided.

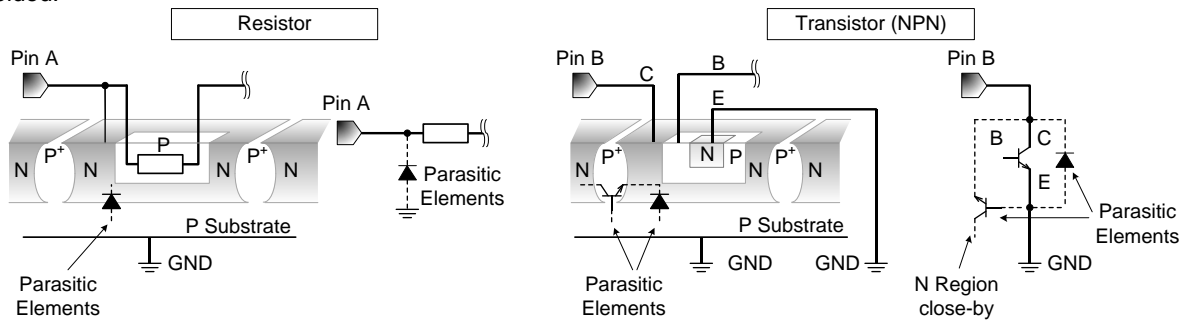

Figure 40. Example of monolithic IC structure

13. Ceramic Capacitor

When using a ceramic capacitor, determine the dielectric constant considering the change of capacitance with temperature and the decrease in nominal capacitance due to DC bias and others.

14. Thermal Shutdown Circuit(TSD)

This IC has a built-in thermal shutdown circuit that prevents heat damage to the IC. Normal operation should always be within the IC's maximum junction temperature rating. If however the rating is exceeded for a continued period, the junction temperature ( $T_j$ ) will rise which will activate the TSD circuit that will turn OFF all output pins. When the  $T_j$  falls below the TSD threshold, the circuits are automatically restored to normal operation.

Note that the TSD circuit operates in a situation that exceeds the absolute maximum ratings and therefore, under no circumstances, should the TSD circuit be used in a set design or for any purpose other than protecting the IC from heat damage.

Ordering Information

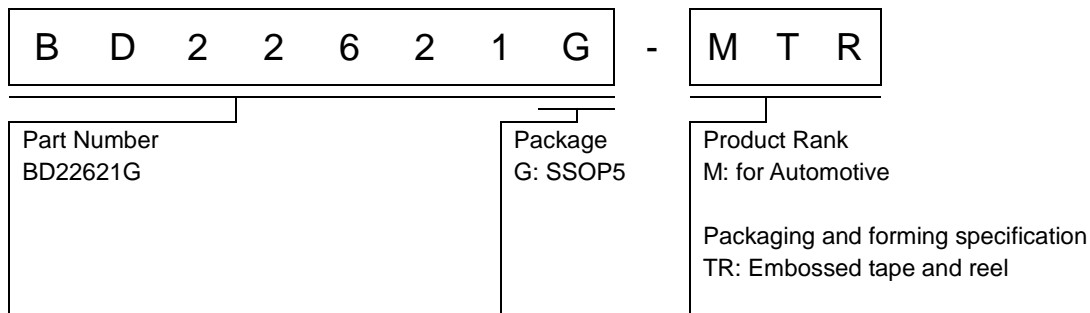

Marking Diagram

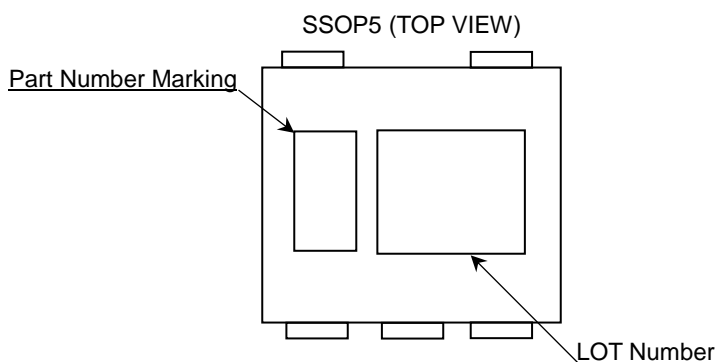

Part Number	Part Number Marking
BD22621G-M	XT

Physical Dimension, Tape and Reel Information

Package Name	SSOP5
--------------	-------

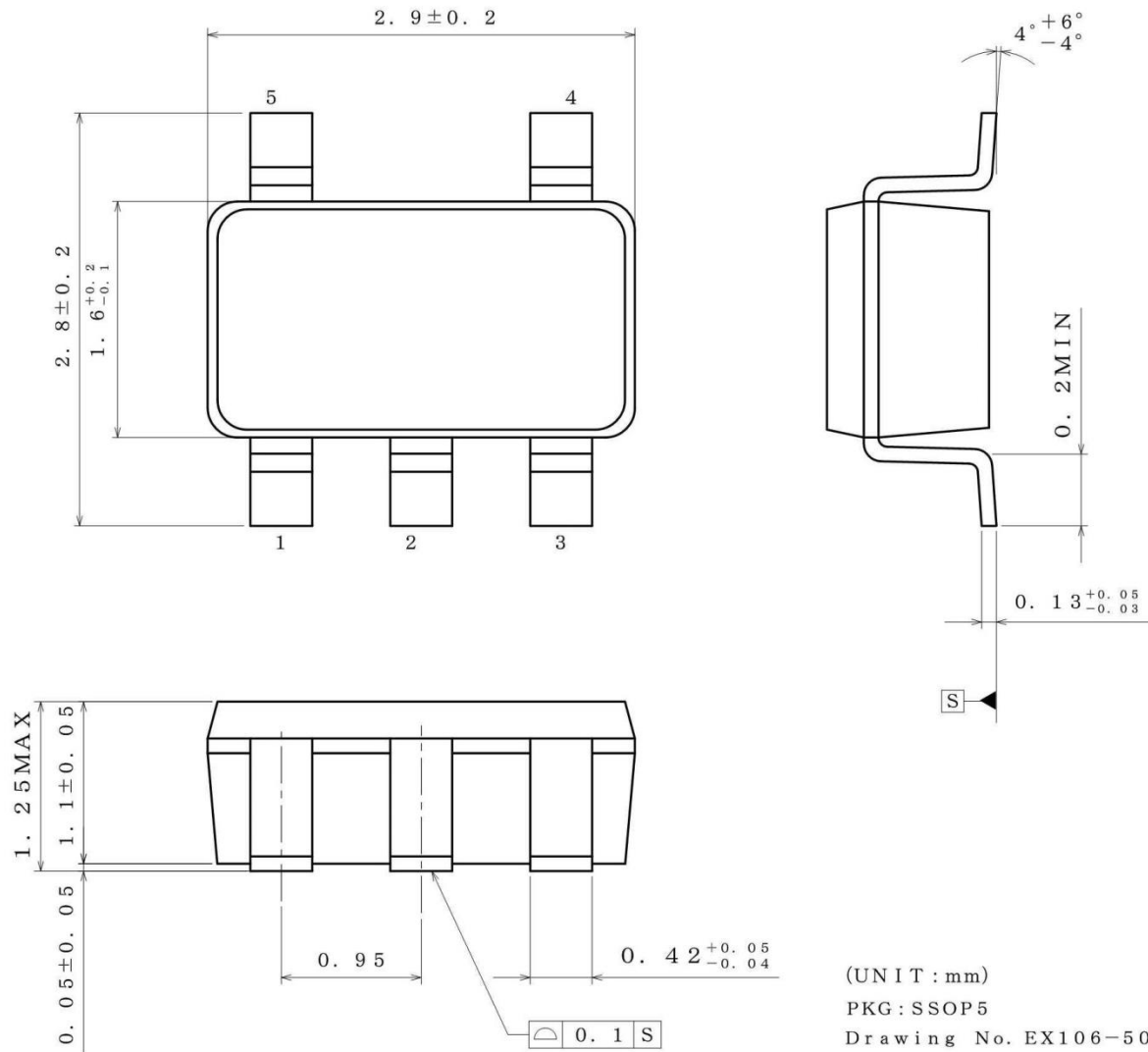

< Tape and Reel Information >

Tape	Embossed carrier tape
Quantity	3000pcs
Direction of feed	TR ( The direction is the 1pin of product is at the upper right when you hold ) ( reel on the left hand and you pull out the tape on the right hand )

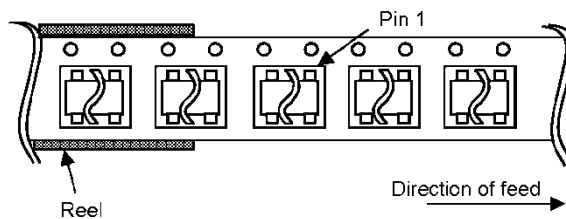

## Revision History

Date	Revision	Changes
2.Nov.2016	001	New Release

# Notice

## Precaution on using ROHM Products

1. If you intend to use our Products in devices requiring extremely high reliability (such as medical equipment <sup>(Note 1)</sup>, aircraft/spacecraft, nuclear power controllers, etc.) and whose malfunction or failure may cause loss of human life, bodily injury or serious damage to property ("Specific Applications"), please consult with the ROHM sales representative in advance. Unless otherwise agreed in writing by ROHM in advance, ROHM shall not be in any way responsible or liable for any damages, expenses or losses incurred by you or third parties arising from the use of any ROHM's Products for Specific Applications.

(Note1) Medical Equipment Classification of the Specific Applications

JAPAN	USA	EU	CHINA
CLASS III	CLASS III	CLASS II b	CLASS III
CLASS IV		CLASS III	

2. ROHM designs and manufactures its Products subject to strict quality control system. However, semiconductor products can fail or malfunction at a certain rate. Please be sure to implement, at your own responsibilities, adequate safety measures including but not limited to fail-safe design against the physical injury, damage to any property, which a failure or malfunction of our Products may cause. The following are examples of safety measures:
  - [a] Installation of protection circuits or other protective devices to improve system safety
  - [b] Installation of redundant circuits to reduce the impact of single or multiple circuit failure
3. Our Products are not designed under any special or extraordinary environments or conditions, as exemplified below. Accordingly, ROHM shall not be in any way responsible or liable for any damages, expenses or losses arising from the use of any ROHM's Products under any special or extraordinary environments or conditions. If you intend to use our Products under any special or extraordinary environments or conditions (as exemplified below), your independent verification and confirmation of product performance, reliability, etc. prior to use, must be necessary:
  - [a] Use of our Products in any types of liquid, including water, oils, chemicals, and organic solvents
  - [b] Use of our Products outdoors or in places where the Products are exposed to direct sunlight or dust
  - [c] Use of our Products in places where the Products are exposed to sea wind or corrosive gases, including Cl<sub>2</sub>, H<sub>2</sub>S, NH<sub>3</sub>, SO<sub>2</sub>, and NO<sub>2</sub>
  - [d] Use of our Products in places where the Products are exposed to static electricity or electromagnetic waves
  - [e] Use of our Products in proximity to heat-producing components, plastic cords, or other flammable items
  - [f] Sealing or coating our Products with resin or other coating materials
  - [g] Use of our Products without cleaning residue of flux (even if you use no-clean type fluxes, cleaning residue of flux is recommended); or Washing our Products by using water or water-soluble cleaning agents for cleaning residue after soldering
  - [h] Use of the Products in places subject to dew condensation
4. The Products are not subject to radiation-proof design.
5. Please verify and confirm characteristics of the final or mounted products in using the Products.
6. In particular, if a transient load (a large amount of load applied in a short period of time, such as pulse. is applied, confirmation of performance characteristics after on-board mounting is strongly recommended. Avoid applying power exceeding normal rated power; exceeding the power rating under steady-state loading condition may negatively affect product performance and reliability.
7. De-rate Power Dissipation depending on ambient temperature. When used in sealed area, confirm that it is the use in the range that does not exceed the maximum junction temperature.
8. Confirm that operation temperature is within the specified range described in the product specification.
9. ROHM shall not be in any way responsible or liable for failure induced under deviant condition from what is defined in this document.

## Precaution for Mounting / Circuit board design

1. When a highly active halogenous (chlorine, bromine, etc.) flux is used, the residue of flux may negatively affect product performance and reliability.
2. In principle, the reflow soldering method must be used on a surface-mount products, the flow soldering method must be used on a through hole mount products. If the flow soldering method is preferred on a surface-mount products, please consult with the ROHM representative in advance.

For details, please refer to ROHM Mounting specification

### Precautions Regarding Application Examples and External Circuits

1. If change is made to the constant of an external circuit, please allow a sufficient margin considering variations of the characteristics of the Products and external components, including transient characteristics, as well as static characteristics.
2. You agree that application notes, reference designs, and associated data and information contained in this document are presented only as guidance for Products use. Therefore, in case you use such information, you are solely responsible for it and you must exercise your own independent verification and judgment in the use of such information contained in this document. ROHM shall not be in any way responsible or liable for any damages, expenses or losses incurred by you or third parties arising from the use of such information.

### Precaution for Electrostatic

This Product is electrostatic sensitive product, which may be damaged due to electrostatic discharge. Please take proper caution in your manufacturing process and storage so that voltage exceeding the Products maximum rating will not be applied to Products. Please take special care under dry condition (e.g. Grounding of human body / equipment / solder iron, isolation from charged objects, setting of Ionizer, friction prevention and temperature / humidity control).

### Precaution for Storage / Transportation

1. Product performance and soldered connections may deteriorate if the Products are stored in the places where:
  - [a] the Products are exposed to sea winds or corrosive gases, including Cl<sub>2</sub>, H<sub>2</sub>S, NH<sub>3</sub>, SO<sub>2</sub>, and NO<sub>2</sub>
  - [b] the temperature or humidity exceeds those recommended by ROHM
  - [c] the Products are exposed to direct sunshine or condensation
  - [d] the Products are exposed to high Electrostatic
2. Even under ROHM recommended storage condition, solderability of products out of recommended storage time period may be degraded. It is strongly recommended to confirm solderability before using Products of which storage time is exceeding the recommended storage time period.
3. Store / transport cartons in the correct direction, which is indicated on a carton with a symbol. Otherwise bent leads may occur due to excessive stress applied when dropping of a carton.
4. Use Products within the specified time after opening a humidity barrier bag. Baking is required before using Products of which storage time is exceeding the recommended storage time period.

### Precaution for Product Label

A two-dimensional barcode printed on ROHM Products label is for ROHM's internal use only.

### Precaution for Disposition

When disposing Products please dispose them properly using an authorized industry waste company.

### Precaution for Foreign Exchange and Foreign Trade act

Since concerned goods might be fallen under listed items of export control prescribed by Foreign exchange and Foreign trade act, please consult with ROHM in case of export.

### Precaution Regarding Intellectual Property Rights

1. All information and data including but not limited to application example contained in this document is for reference only. ROHM does not warrant that foregoing information or data will not infringe any intellectual property rights or any other rights of any third party regarding such information or data.
2. ROHM shall not have any obligations where the claims, actions or demands arising from the combination of the Products with other articles such as components, circuits, systems or external equipment (including software).
3. No license, expressly or implied, is granted hereby under any intellectual property rights or other rights of ROHM or any third parties with respect to the Products or the information contained in this document. Provided, however, that ROHM will not assert its intellectual property rights or other rights against you or your customers to the extent necessary to manufacture or sell products containing the Products, subject to the terms and conditions herein.

### Other Precaution

1. This document may not be reprinted or reproduced, in whole or in part, without prior written consent of ROHM.
2. The Products may not be disassembled, converted, modified, reproduced or otherwise changed without prior written consent of ROHM.
3. In no event shall you use in any way whatsoever the Products and the related technical information contained in the Products or this document for any military purposes, including but not limited to, the development of mass-destruction weapons.
4. The proper names of companies or products described in this document are trademarks or registered trademarks of ROHM, its affiliated companies or third parties.

**General Precaution**

1. Before you use our Products, you are requested to carefully read this document and fully understand its contents. ROHM shall not be in any way responsible or liable for failure, malfunction or accident arising from the use of any ROHM's Products against warning, caution or note contained in this document.
2. All information contained in this document is current as of the issuing date and subject to change without any prior notice. Before purchasing or using ROHM's Products, please confirm the latest information with a ROHM sales representative.
3. The information contained in this document is provided on an "as is" basis and ROHM does not warrant that all information contained in this document is accurate and/or error-free. ROHM shall not be in any way responsible or liable for any damages, expenses or losses incurred by you or third parties resulting from inaccuracy or errors of or concerning such information.

## Looking for pricing, stock, or lifecycle information?

Click below to explore more details on WIN SOURCE:

-  [View BD22621G-MTR on WIN SOURCE](#)
-  [Rohm Semiconductor](#) Information

## Optimize Your Supply Chain with WIN SOURCE Solutions

-  Global Sourcing Solution
-  Obsolete Management
-  Cost Control Management
-  Shortage Management
-  Alternative Solution
-  Excess Inventory Management