



**THE DATASHEET OF
ASMCI-0805-R10M-T**



SMD Multilayer Chip Inductor for Choke



2.0 x 1.25 x 0.85mm
/2.0 x 1.25 x 1.25mm

ASMCI-0805



RoHS
Compliant

FEATURES:

- Monolithic structure designed for high reliability
- Excellent solderability and heat resistance
- Magnetic shield designed to eliminate cross coupling
- High DC current and low DCR

APPLICATIONS:

Choke circuits in DC power line for PC, mobile phones, digital cameras, camcorder, and music players.

ELECTRICAL SPECIFICATIONS:

Operating Temperature: -40°C to +85°C

Storage Temperature: -10°C to +40°C, 70% RH max

Part Number ASMCI-0805- Inductance Code	Inductance	Tolerance	DCR	SRF Min.	Max. Rated Current	Tape and Reel Qty
Units	μH	%	Ω ± 30%	MHz	mA	
Symbol	L	M=±20%, N=±30%	DCR	SRF	Ir	
ASMCI-0805-R10	0.1	M, N	0.07	235	1000	4k
ASMCI-0805-R22	0.22	M, N	0.13	170	800	4k
ASMCI-0805-R47	0.47	M, N	0.18	125	550	4k
ASMCI-0805-1R0	1.0	M, N	0.20	75	300	4k
ASMCI-0805-2R2	2.2	M, N	0.28	50	220	4k
ASMCI-0805-4R7	4.7	M, N	0.30	25	180	4k
ASMCI-0805-100	10	M, N	0.50	15	60	3k

Test Conditions

- Ambient Temperature: 20± 15°C
- Relative Humidity: 65%±20%
- Air Pressure: 86KPa to 106KPa

Inductance (L): High Accuracy RF Impedance/Material Analyzer-HP4291B+HP16192A or Equivalent, 1MHz, -20dBm or 50mV.

Direct Current Resistance (DCR): High Accuracy Milliohmeter-HP4338B or Equivalent

Self-Resonant Frequency (SRF): High Accuracy RF Impedance/Material Analyzer HP4291B+HP16192A or Equivalent, -20dBm or 50mV.

Rated current (Ir): HP6632B system DC power supply, HP4291B+HP16192A+HP16200A or equivalent.

Definition of Rated Current (Ir): Ir is the value of DC current as inductance L (μH) decreased just 50% against initial value.



SMD Multilayer Chip Inductor for Choke

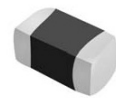

2.0 x 1.25 x 0.85mm
/2.0 x 1.25 x 1.25mm

ASMCI-0805



RoHS
Compliant

PART IDENTIFICATIONS:

ASMCI-0805 - -

Inductance Code
Please refer to the table above

Tolerance
M: ±20%
N: ±30%

Packaging
T: Tape and Reel
(4kpcs / reel for 0.1~4.7μH;
3kpcs / reel for 10μH)

OUTLINE DRAWING:

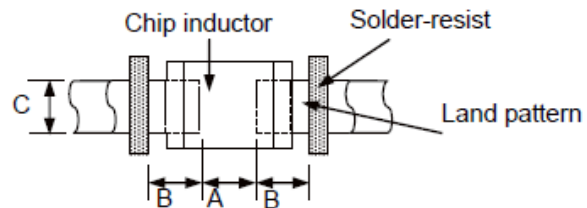
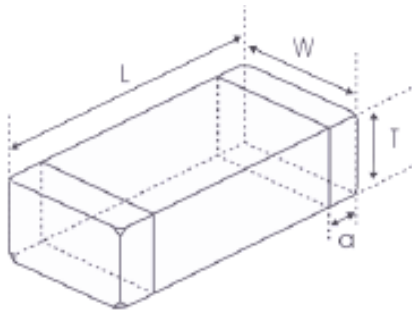

L	W	T	a
2.0 (+0.3, -0.1) [0.079 (+0.012, -0.004)]	1.25±0.2 [0.049±0.008]	0.85±0.2[0.033±0.008] for 0.1~4.7μH 1.25±0.2[0.049±0.008] for 10μH	0.5±0.3 [0.020±0.012]

A	B	C
0.80~1.20	0.80~1.20	0.90~1.60

Dimension: mm [inch]

Dimension: mm

MATERIALS:

Side View

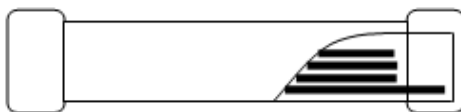

Top View

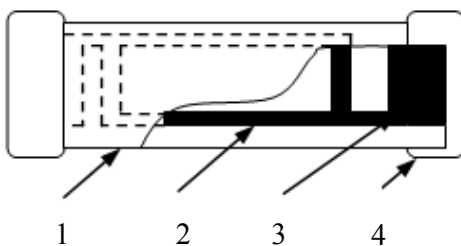

Structure of Electro-plating

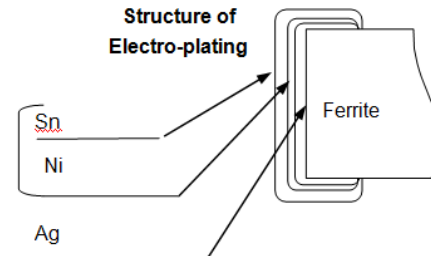

	Part Name	Material
1	Base Material	Ferrite
2	Internal Conductor	Ag
3	Pull out Electrode	Ag
4	Terminal Electrode	Ag (Inner layer) Ni-Sn (Outer layer)

SMD Multilayer Chip Inductor for Choke



2.0 x 1.25 x 0.85mm
/2.0 x 1.25 x 1.25mm

ASMCI-0805



RoHS
Compliant

REFLOW PROFILE:

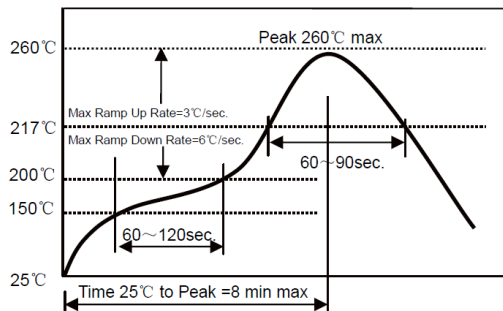

- Δ Preheat condition: 150 ~200°C /60~120sec.
- Δ Allowed time above 217°C: 60~90sec.
- Δ Max temp: 260°C
- Δ Max time at max temp: 10sec.
- Δ Solder paste: Sn/3.0Ag/0.5Cu
- Δ Allowed Reflow time: 2x max

TAPE & REEL:

T: 4,000pcs / reel for 0.1~4.7μH; 3,000pcs / reel for 10μH

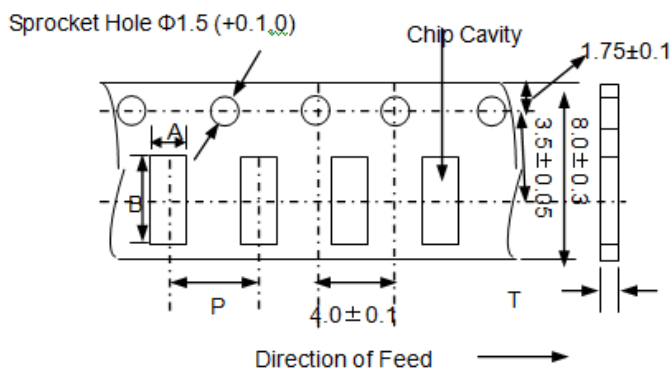

A	B	P	T(max)
1.5 ± 0.2	2.3 ± 0.2	4.0 ± 0.1	1.1

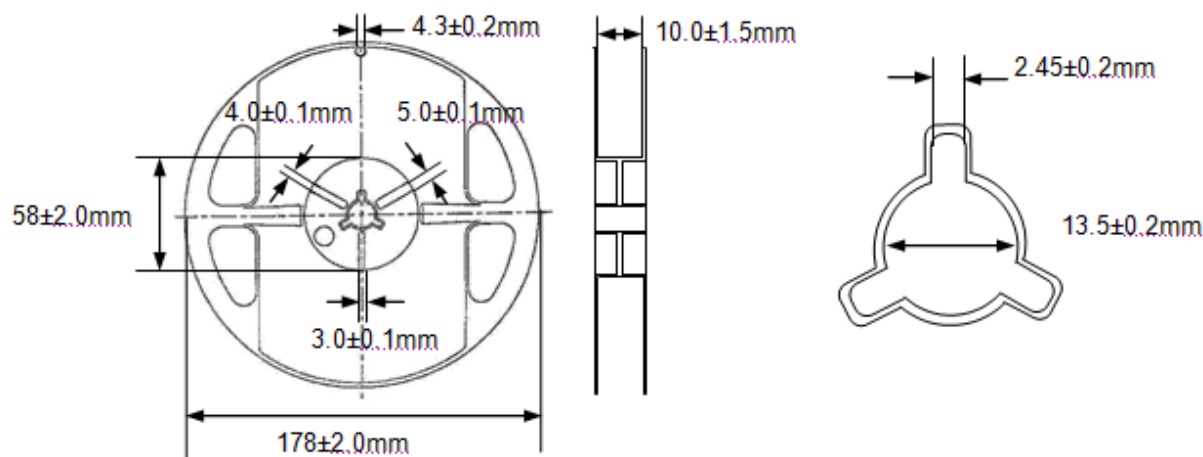

Dimension: mm

ATTENTION: Abracon Corporation's products are COTS – Commercial-Off-The-Shelf products; suitable for Commercial, Industrial and, where designated, Automotive Applications. Abracon's products are not specifically designed for Military, Aviation, Aerospace, Life-dependant Medical applications or any application requiring high reliability where component failure could result in loss of life and/or property. For applications requiring high reliability and/or presenting an extreme operating environment, written consent and authorization from Abracon Corporation is required. Please contact Abracon Corporation for more information.

ABRACON IS
ISO 9001:2008
CERTIFIED



**ABRACON
CORPORATION**

Visit www.abracon.com for Terms & Conditions of Sale **Revised: 02.08.13**
30332 Esperanza, Rancho Santa Margarita, California 9268
tel 949-546-8000 | fax 949-546-8001 | www.abracon.com

Looking for pricing, stock, or lifecycle information?

Click below to explore more details on WIN SOURCE:

 [View ASMCI-0805-R10M-T on WIN SOURCE](#)

 [Abracon LLC Information](#)

Optimize Your Supply Chain with WIN SOURCE Solutions

-  Global Sourcing Solution
-  Obsolete Management
-  Cost Control Management
-  Shortage Management
-  Alternative Solution
-  Excess Inventory Management