



**THE DATASHEET OF  
APC-817A1-SL**



## Specification for APC-817 Series

### APC-817

*DIP4, DC Input, Photo Transistor Coupler*

The APC-817 series combines an AlGaAs infrared emitting diode as the emitter which is optically coupled to a silicon planar phototransistor detector in a plastic DIP4 package with different lead forming options.

With the robust coplanar double mold structure, APC-817 series provide the most stable isolation feature.

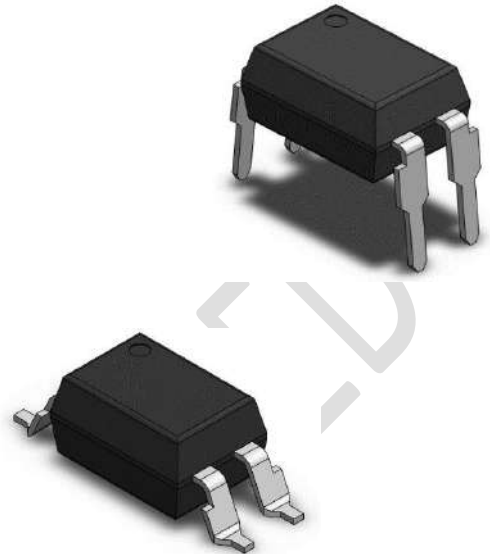

### Features:

- High isolation  $V_{rms}$ : 5000V
- CTR flexibility available
- DC input with transistor output
- Operating temperature: - 55 °C to 110 °C
- RoHS & REACH Compliance
- MSL Class 1
- Halogen free (Optional)
- UL - UL1577
- VDE - EN60747-5-5(VDE0884-5)
- CQC - GB4943.1, GB8898
- cUL- CSA Component Acceptance Service Notice No. 5A

### Applications:

- Switch mode power supplies
- Programmable controllers
- Household appliances
- Office equipment

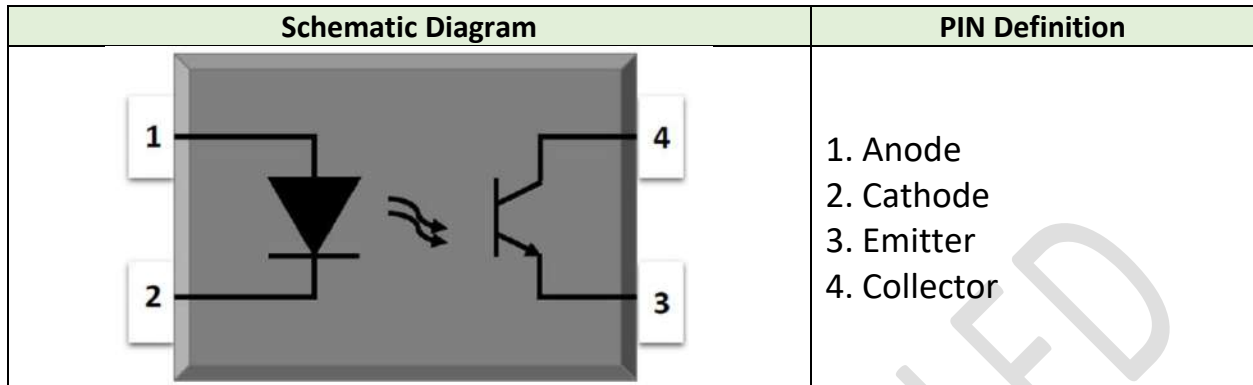

Absolute Maximum Ratings				
Parameter	Symbol	Value	Unit	Note
Input				
Forward Current	$I_F$	60	mA	
Peak Forward Current	$I_{FP}$	1	A	1
Reverse Voltage	$V_R$	6	V	
Input Power Dissipation	$P_I$	100	mW	
Output				
Collector – Emitter Voltage	$V_{CEO}$	35	V	
Emitter – Collector Voltage	$V_{ECO}$	6	V	
Collector Current	$I_C$	50	mA	
Output Power Dissipation	$P_O$	150	mW	
Common				
Total Power Dissipation	$P_{tot}$	200	mW	
Isolation Voltage	$V_{iso}$	5000	V <sub>rms</sub>	2
Operating Temperature	$T_{opr}$	-55~110	°C	
Storage Temperature	$T_{stg}$	-55~125	°C	
Soldering Temperature	$T_{sol}$	260	°C	

Note 1. 100μs pulse, 100Hz frequency

Note 2. AC For 1 Minute, R.H. = 40 ~ 60%

Electrical Optical Characteristics at T <sub>a</sub> =25°C								
Parameter	Symbol	min	Typ.	Max.	unit	Test Condition	Note	
Input								
Forward Voltage	V <sub>F</sub>	-	1.24	1.4	V	I <sub>F</sub> =10mA		
Reverse Current	I <sub>R</sub>	-	-	10	μA	V <sub>R</sub> =6V		
Input Capacitance	C <sub>in</sub>	-	10	-	pF	V=0, f=1kHz		
Output								
Collector Dark Current	I <sub>CEO</sub>	-	-	100	nA	V <sub>EC</sub> =20V, I <sub>F</sub> =0		
Collector – Emitter Breakdown Voltage	BV <sub>CEO</sub>	35	-	-	V	I <sub>C</sub> =0.1mA, I <sub>F</sub> =0		
Emitter – Collector Breakdown Voltage	BV <sub>ECO</sub>	6	-	-	V	I <sub>E</sub> =0.1mA, I <sub>F</sub> =0		
Transfer Characteristics								
Current Transfer Ratio	<b>APC-817A1</b>	CTR	80	-	160	%	I <sub>F</sub> =5mA, V <sub>CE</sub> =5V	5
	<b>APC-817B1</b>		130	-	260			
	<b>APC-817C1</b>		200	-	400			
	<b>APC-817D1</b>		300	-	600			
Collector – Emitter Saturation Voltage	V <sub>CE(sat)</sub>	-	0.06	0.2	V	I <sub>F</sub> =20mA, I <sub>C</sub> =1mA		
Isolation Resistance	R <sub>ISO</sub>	10 <sup>12</sup>	10 <sup>14</sup>	-	Ω	DC500V, 40~60% R.H.		
Floating Capacitance	C <sub>IO</sub>	-	0.4	1	pF	V=0, f=1MHz		
Response Time (rise)	Tr	-	3	18	μs	V <sub>CE</sub> =2V, I <sub>C</sub> =2mA RL=100Ω	3	
Response Time (fall)	Tf	-	4	18	μs		3	
Cut-off Frequency	f <sub>c</sub>	-	80	-	kHz	V <sub>CE</sub> =2V, I <sub>C</sub> =2mA RL=100Ω, -3dB	4	

Note 3. Fig.12&13

Note 4. Fig.14

Note 5. CTR Value varies for each rank

### Naming System:

#### **APC-817A1-SL**

A1: Indicated to the CTR value listed on Page 3 (A1/B1/C1/D1)

S: Indicated to the PIN type listed on Page 7 to Page 9 (None/M/S/SL/SML)

**Characteristic Curves**

**Fig 1. Forward Current vs. Ambient Temperature**

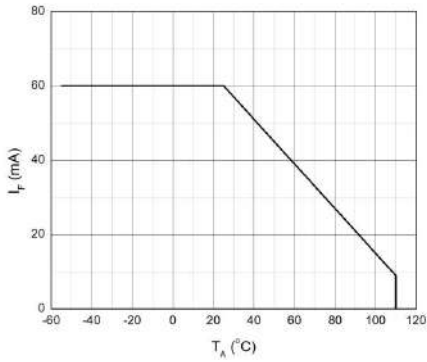

**Fig 2. Collector Power Dissipation vs. Ambient Temperature**

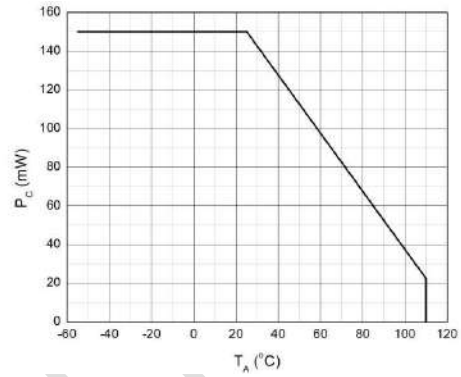

**Fig 3. Forward Current vs. Forward Voltage**

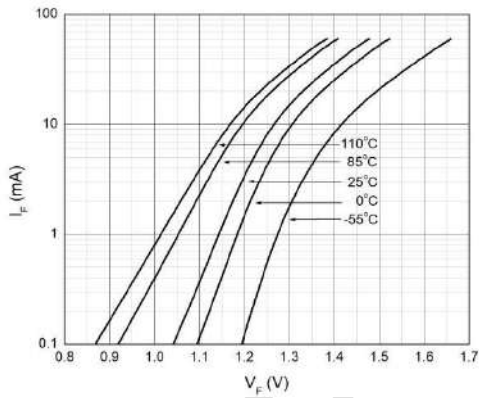

**Fig 4. Collector Dark Current vs. Ambient Temperature**

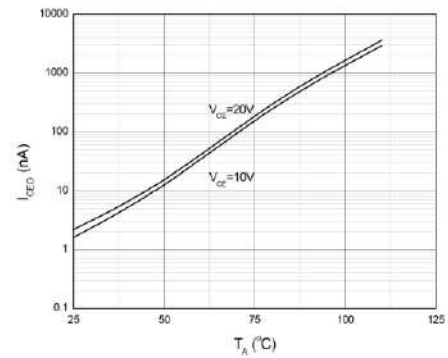

**Fig 5. Collector Current vs. Collector-emitter Voltage**

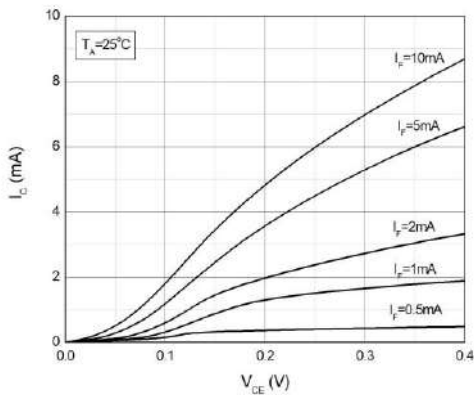

**Fig 6. Collector Current vs. Collector-emitter Voltage**

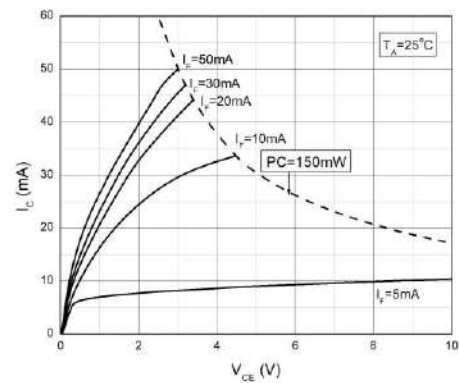

**Fig 7. Normalized Current Transfer Ratio vs. Forward Current**

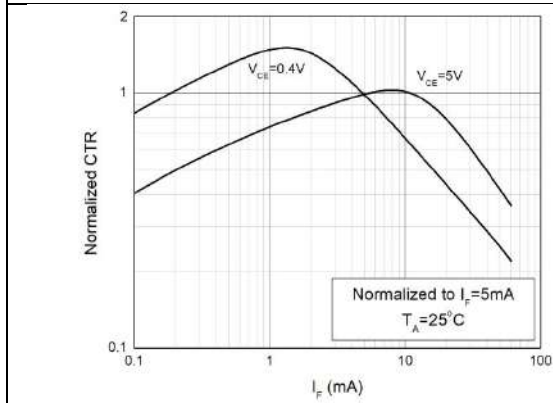

**Fig 8. Normalized Current Transfer Ratio vs. Ambient Temperature**

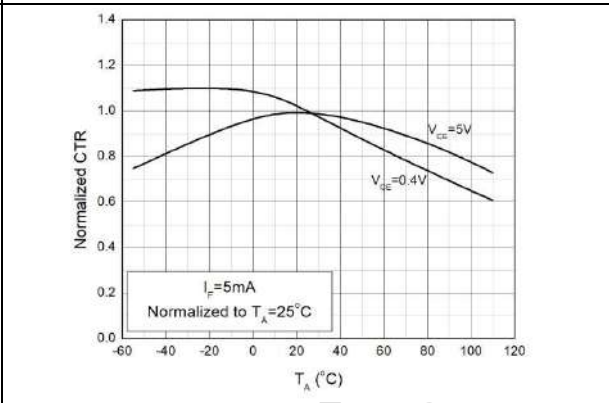

**Fig 9. Collector-emitter Saturation Voltage vs. Ambient Temperature**

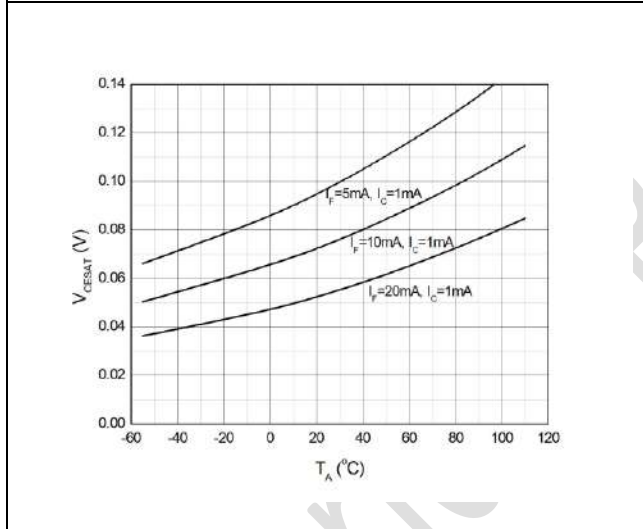

**Fig 10. Switching Time vs. Load Resistance**

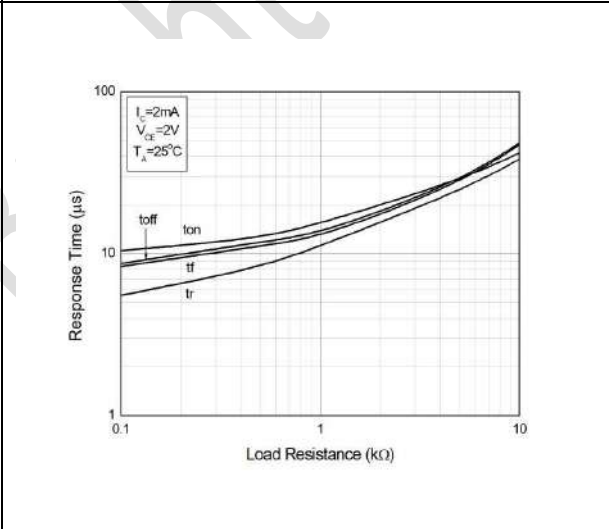

**Fig 11. Frequency Response**

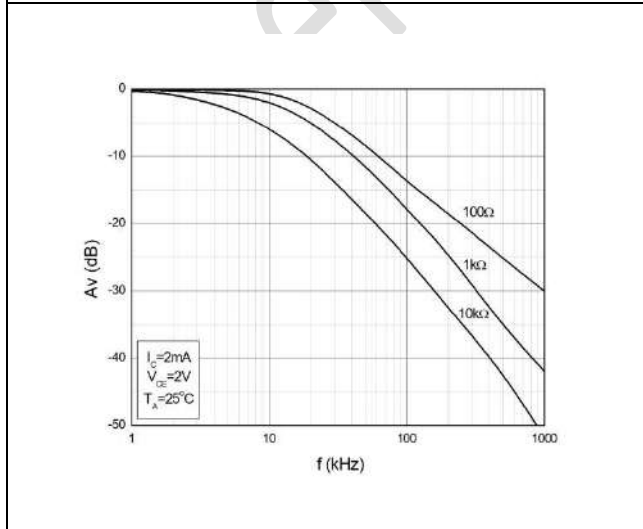

**Fig 12. Test Circuits of Response Time**

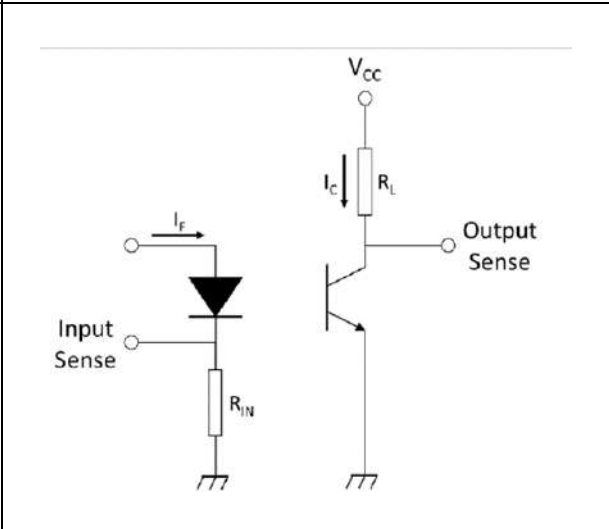



# AMERICAN BRIGHT OPTOELECTRONICS CORP.

Fig 13. Curves of Response Time

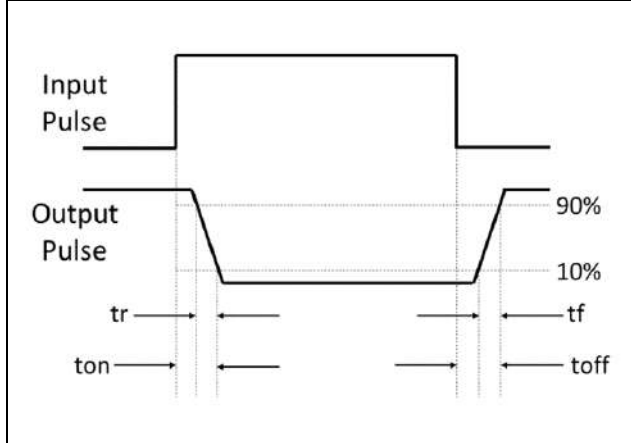
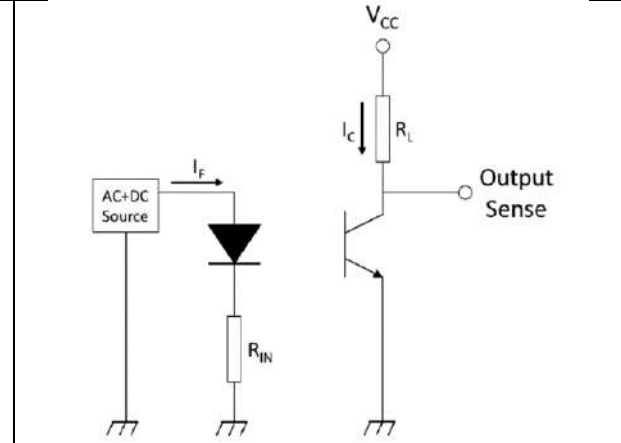

Fig 14. Test Circuits of Frequency Response



American Bright

**Package Dimension (mm)**

**Standard DIP – Through hole (DIP Type) – APC-817xx**

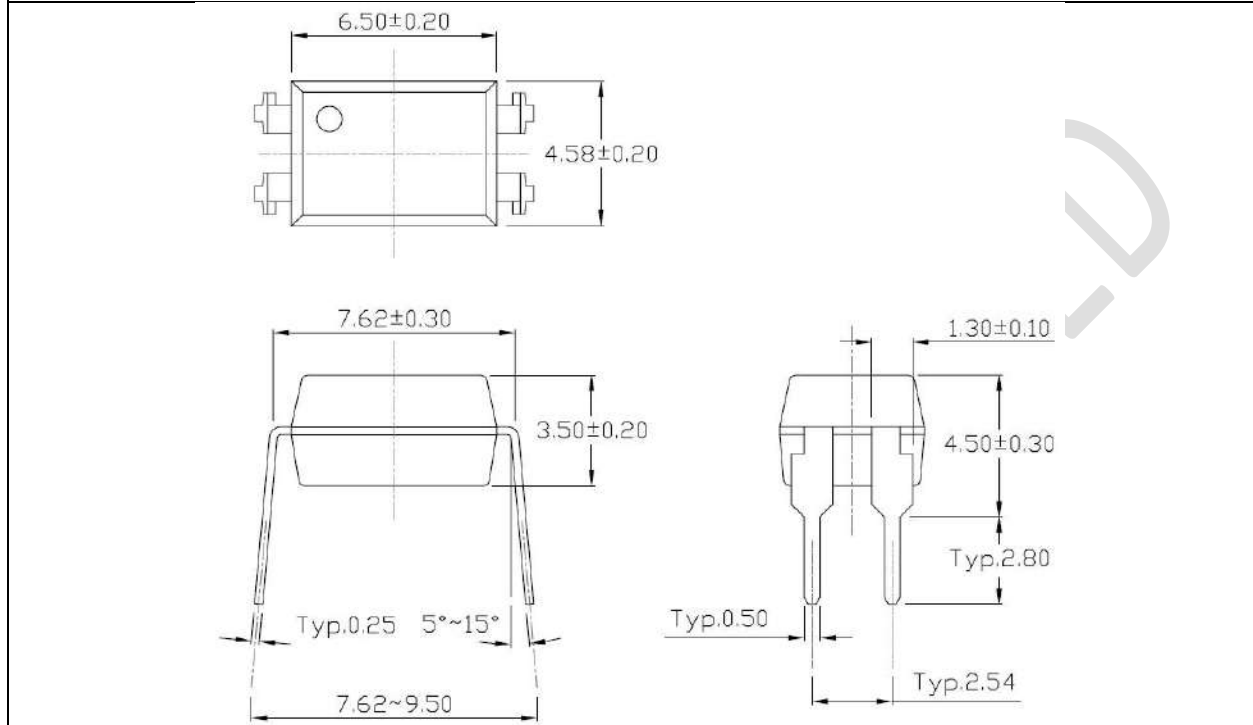

**Gullwing (400mil) Lead Forming – Through Hole (M Type) – APC-817xx-M**

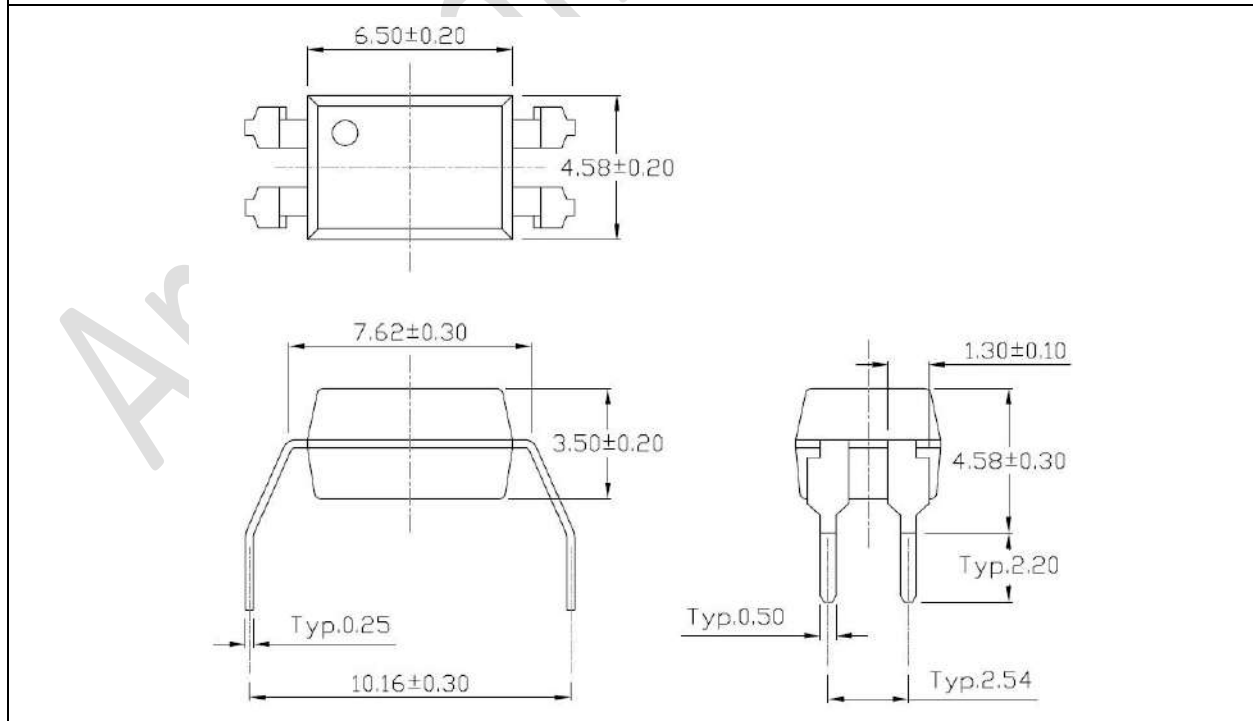



# AMERICAN BRIGHT OPTOELECTRONICS CORP.

## Surface Mount Lead Forming (S Type) – APC817xx-S

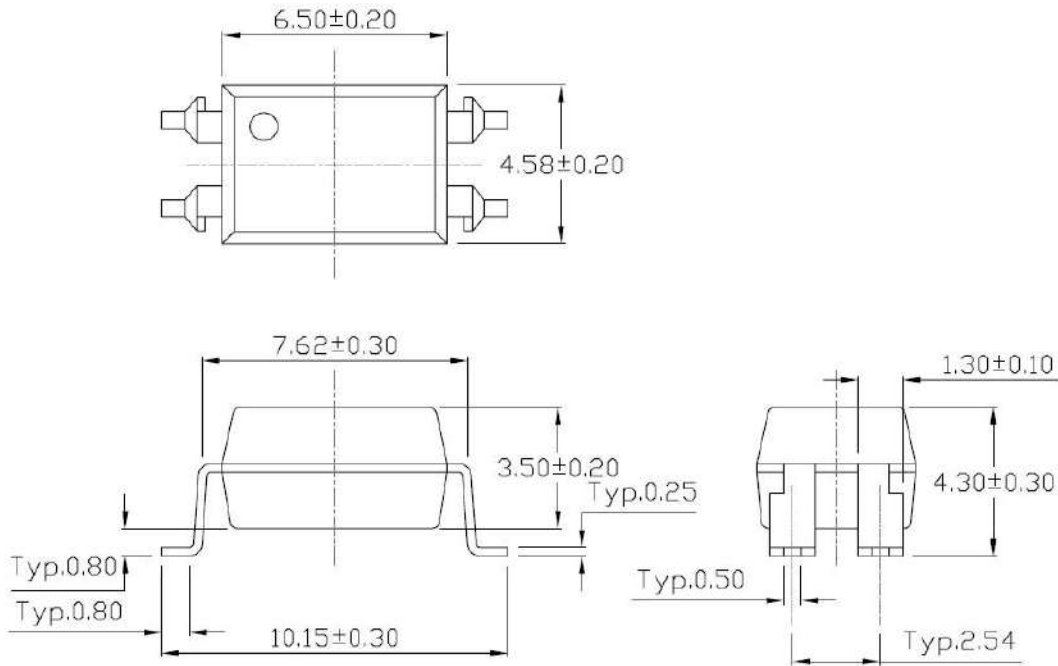

## Surface Mount (Low Profile) Lead Forming (SL Type) - APC-817xx-SL

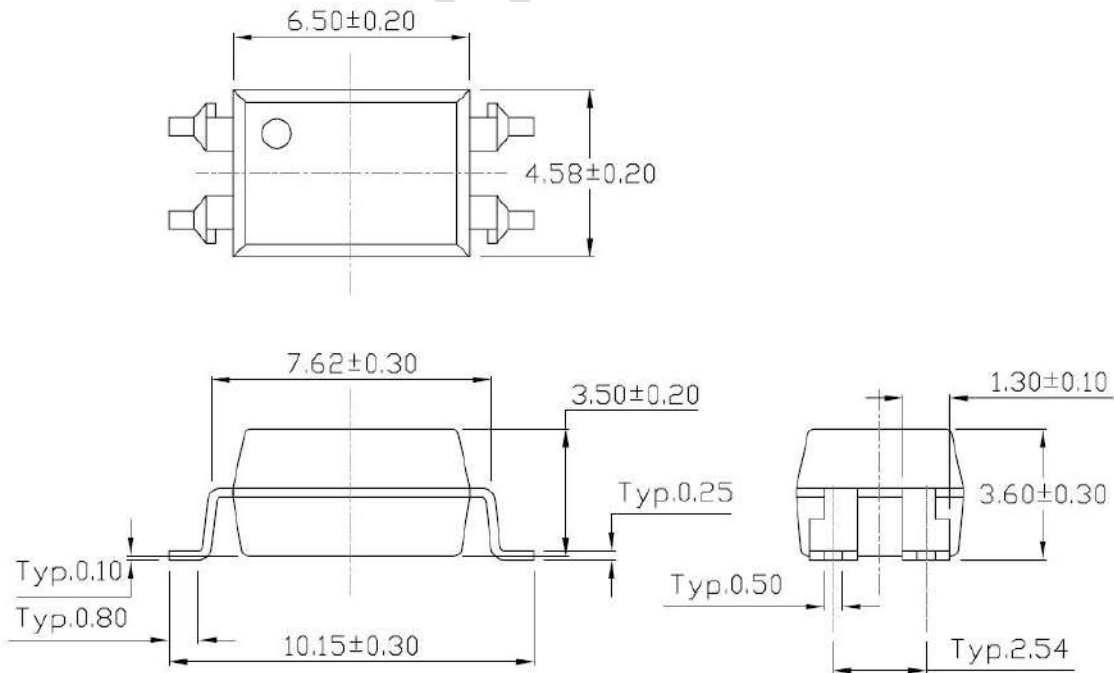



# AMERICAN BRIGHT OPTOELECTRONICS CORP.

## Surface Mount (Gullwing) Lead Forming (SLM Type) - APC-817xx-SLM

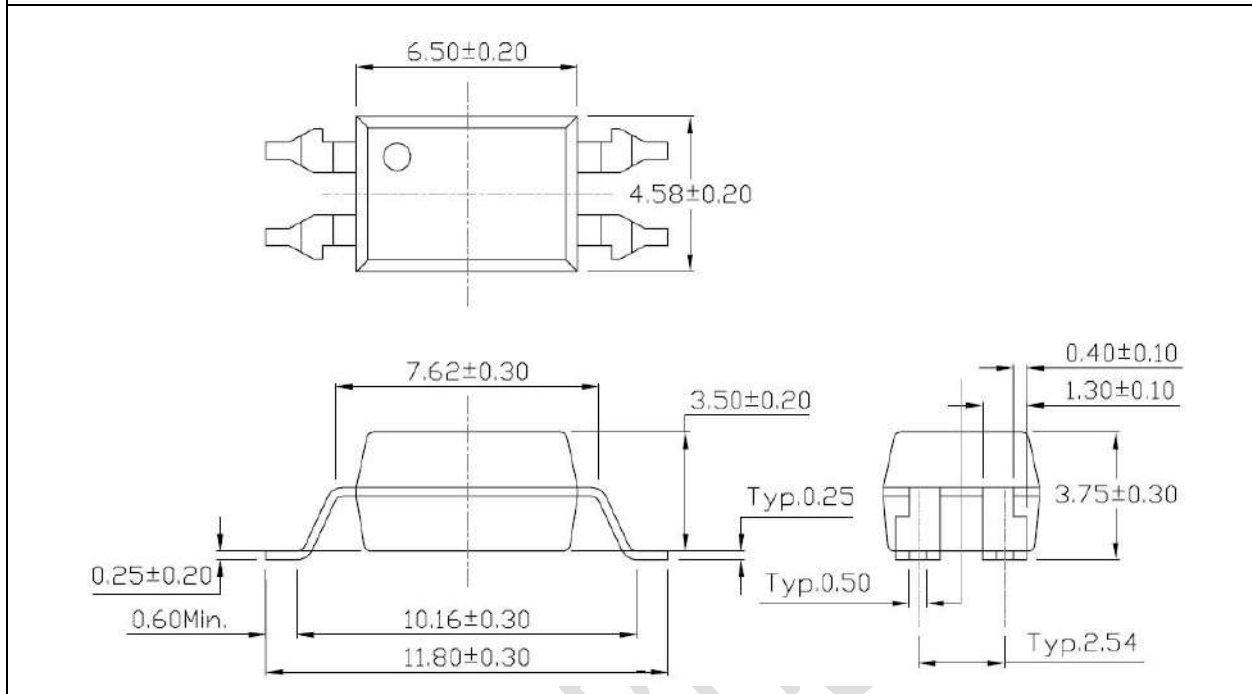

### Recommended Solder Mask (mm)

#### Surface Mount Lead Forming & Surface Mount (Low Profile) Lead Forming

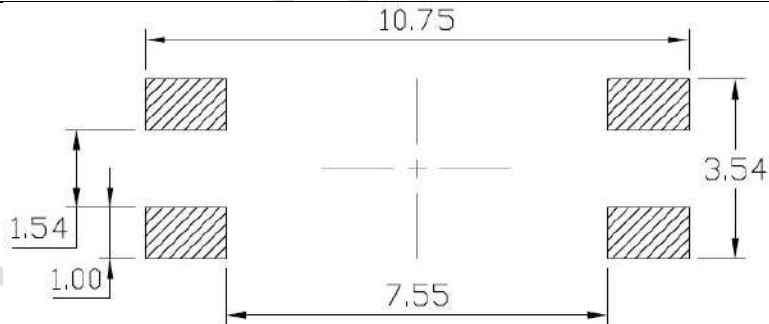

#### Surface Mount (Gullwing) Lead Forming

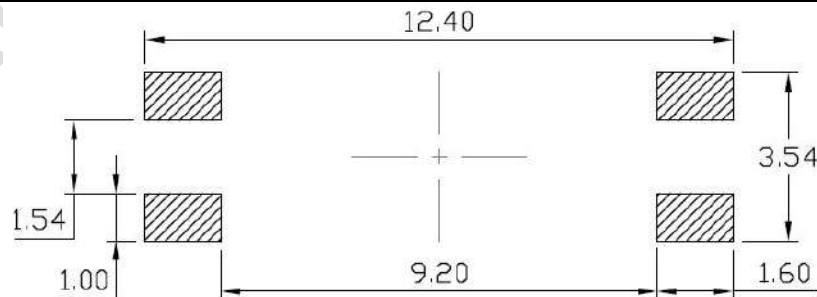

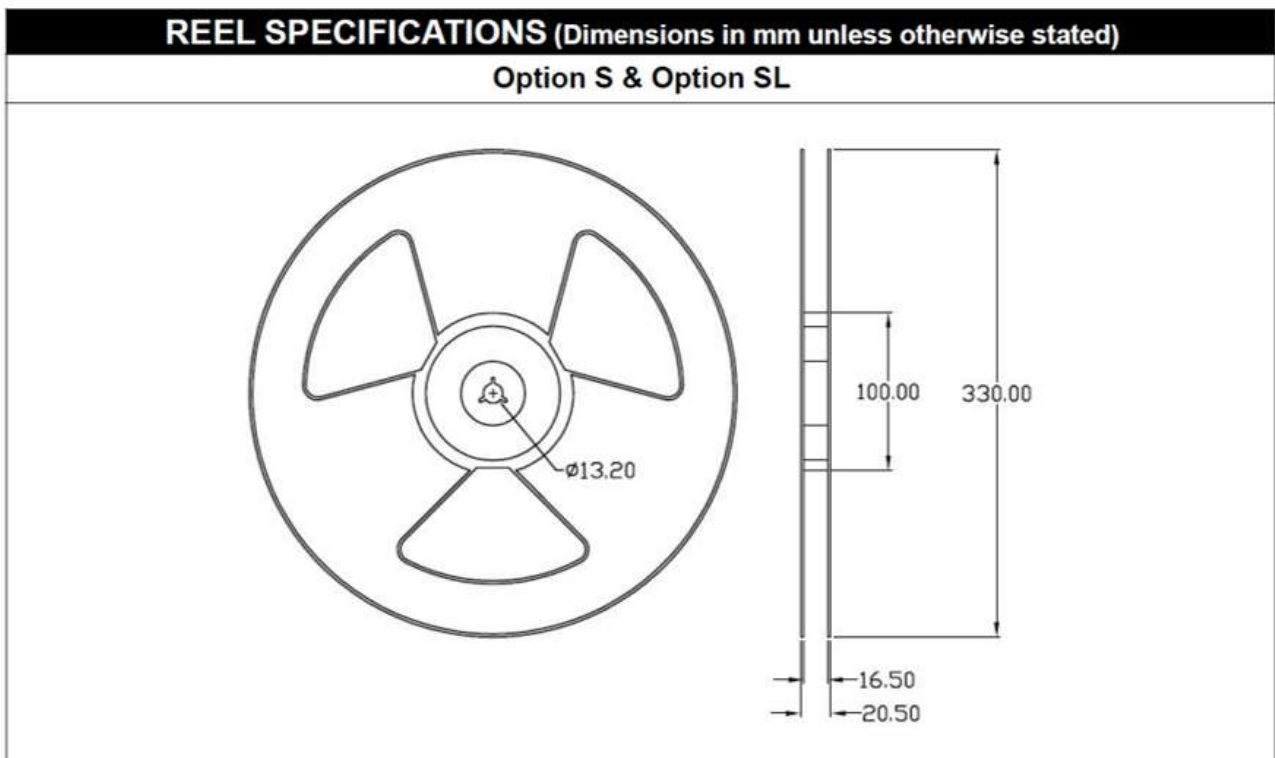
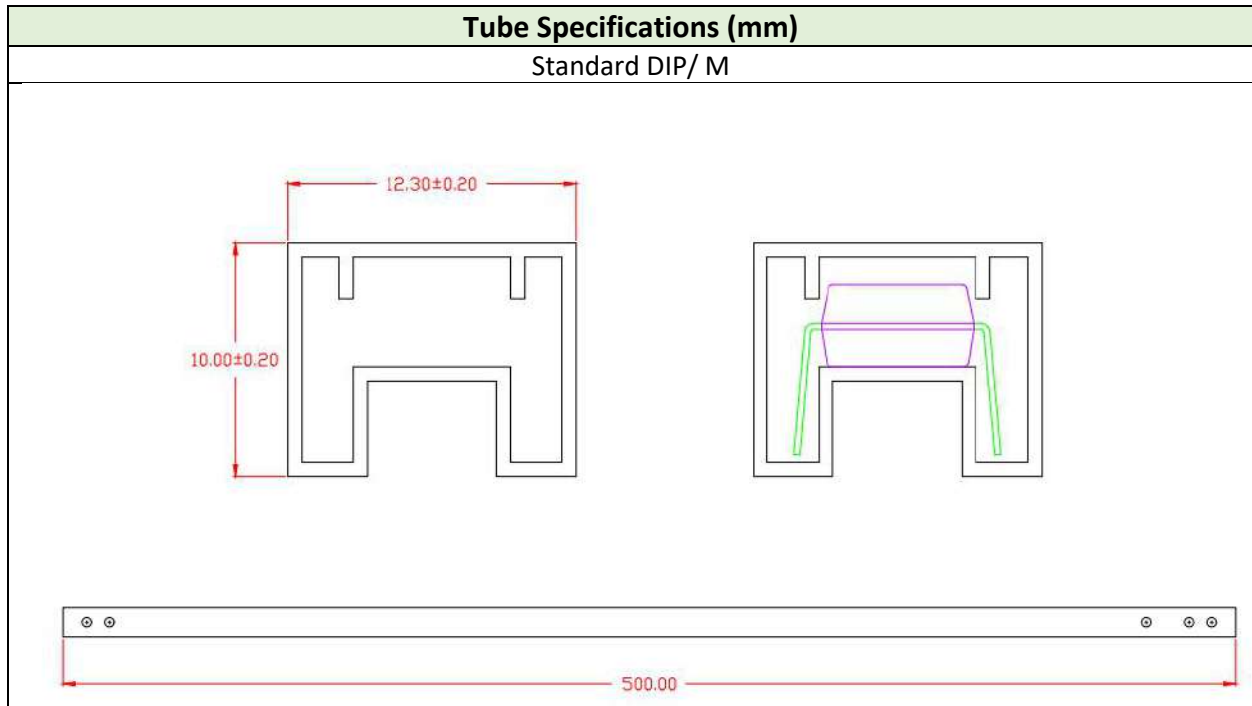

**Reflow Information**

**Reflow Profile**

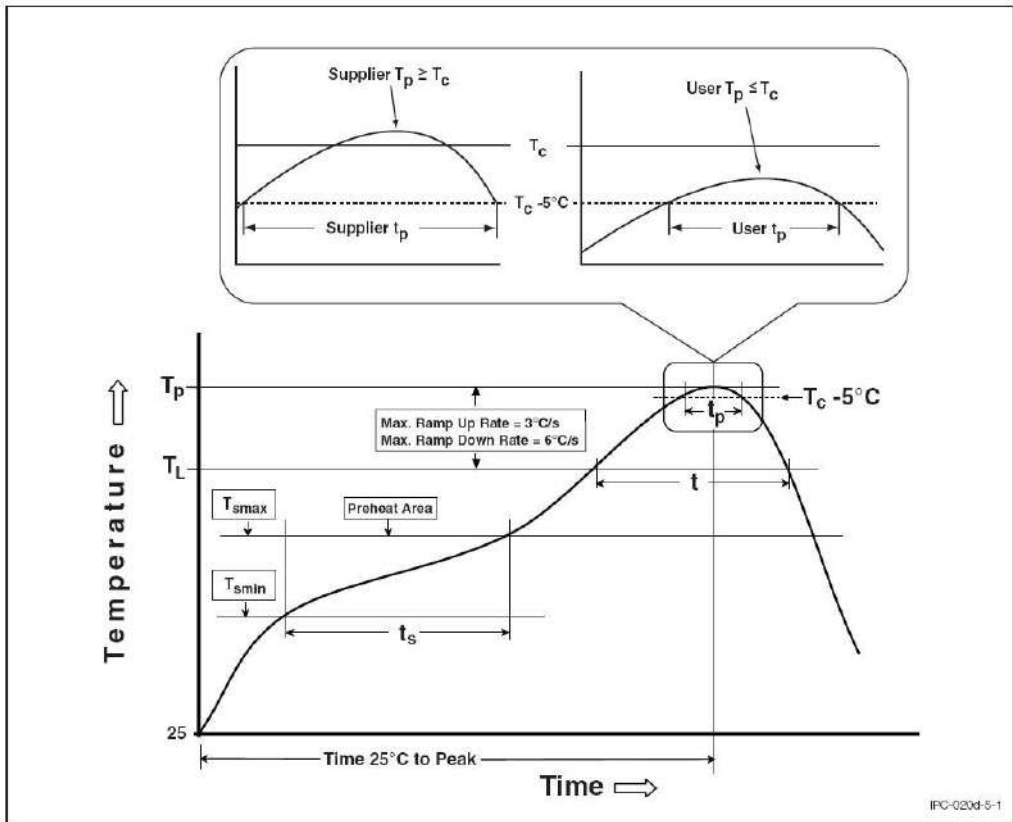



Profile Feature	Sn-Pb Assembly Profile	Pb-free Assembly Profile
Temperature min. ( $T_{s, min}$ )	100°C	150°C
Temperature Max. ( $T_{s, Max}$ )	150°C	200°C
Time ( $t_s$ ) from ( $T_{s, min}$ to $T_{s, max}$ )	60-120 s	60-120 s
Ramp-up Rate ( $t_L$ to $t_P$ )	3°C/s max.	3°C/s max.
Liquidous Temperature ( $T_L$ )	183°C	217°C
Time ( $t_L$ ) Maintained Above ( $T_L$ )	60-150 s	60-150 s
Peak Body Package Temperature	230°C +0°C/ -5°C	260°C +0°C/ -5°C
Time ( $t_P$ ) within 5°C of 260°C	20 s	30 s
Ramp-down Rate ( $T_P$ to $T_L$ )	6°C/s max.	6°C/s max.
Time 25°C to Peak Temperature	6 minutes max.	8 minutes max.

**Disclaimer:**

- American Bright is continually improving the quality, reliability, function and design. American Bright reserves the right to make changes without further notices.
- The characteristic curves shown in this datasheet are representing typical performance which are not guaranteed.
- American Bright makes no warranty, representation or guarantee regarding the suitability of the products for any particular purpose or the continuing production of any product. To the maximum extent permitted by applicable law, American Bright disclaims (a) any and all liability arising out of the application or use of any product, (b) any and all liability, including without limitation special, consequential or incidental damages, and (c) any and all implied warranties, including warranties of fitness for particular.
- The products shown in this publication are designed for the general use in electronic applications such as office automation, equipment, communications devices, audio/visual equipment, electrical application and instrumentation purpose, non-infringement and merchantability.
- This product is not intended to be used for military, aircraft, automotive, medical, life sustaining or lifesaving applications or any other application which can result in human injury or death.
- Please contact American Bright sales agent for special application request.
- Immerge unit's body in solder paste is not recommended.
- Parameters provided in datasheets may vary in different applications and performance may vary over time. All operating parameters, including typical parameters, must be validated in each customer application by the customer's technical experts. Product specifications do not expand or otherwise modify American Bright's terms and conditions of purchase, including but not limited to the warranty expressed therein.

## Looking for pricing, stock, or lifecycle information?

Click below to explore more details on WIN SOURCE:

-  [View APC-817A1-SL on WIN SOURCE](#)
-  [American Bright Optoelectronics Corporation](#) Information

## Optimize Your Supply Chain with WIN SOURCE Solutions

-  Global Sourcing Solution
-  Obsolete Management
-  Cost Control Management
-  Shortage Management
-  Alternative Solution
-  Excess Inventory Management