



THE DATASHEET OF AP1010AEN





AP1010

18V 2ch H-Bridge Motor Driver IC

1. General Description

The AP1010 is a 2ch H-Bridge motor driver compatible with motor operating voltage 18V and can drive two DC motors or one stepping motor. The protection circuit has under voltage lockout circuit, thermal shutdown circuit, and overcurrent protection circuit, and overcurrent protection circuit can be disabled with the DIS OCP terminal. The package adopts a small 16-pin QFN package and contributes to downsize Printed Circuit Board.

2. Features

- | | |
|----------------------------------|--|
| • Motor Operating Voltage Range | 6.0V~18V (Control power supply is unnecessary) |
| • Maximum Output Current (DC) | 0.7A @Ta=25°C |
| • H-Bridge On-Resistance | RON(TOP+BOT) = 1.1Ω @Ta=25°C |
| • Parallel Connection Possible | |
| • Under Voltage Lockout Circuit | |
| • Thermal Shutdown Circuit | |
| • Overcurrent Protection Circuit | Overcurrent protection circuit is disabled when DIS OCP terminal = "H" |
| • Operating Temperature Range | -30°C~85°C |
| • Package | 16-pin QFN (3mm×3mm) |

3. Table of Contents

1. General Description	1
2. Features	1
3. Table of Contents	2
4. Block Diagram	3
5. Pin Configurations and Functions	4
5.1 Pin Configurations	4
5.2 Functions	4
6. Absolute maximum Ratings	5
7. Recommended Operating Conditions	6
8. Electrical Characteristics	6
9. Functional Descriptions	7
9.1 Operation Outline	7
9.2 Motor Driver Block Configuration	8
9.3 Protection Circuits	9
10. Recommended External Circuits	10
■ Driving Stepper Motor	10
■ Driving DC Motor	10
11. Package	11
11.1 Outline Dimensions	11
11.2 Recommended Land Pattern	11
11.3 Marking	11
12. Ordering Guide	12
13. Revise History	12
IMPORTANT NOTICE	13

4. Block Diagram

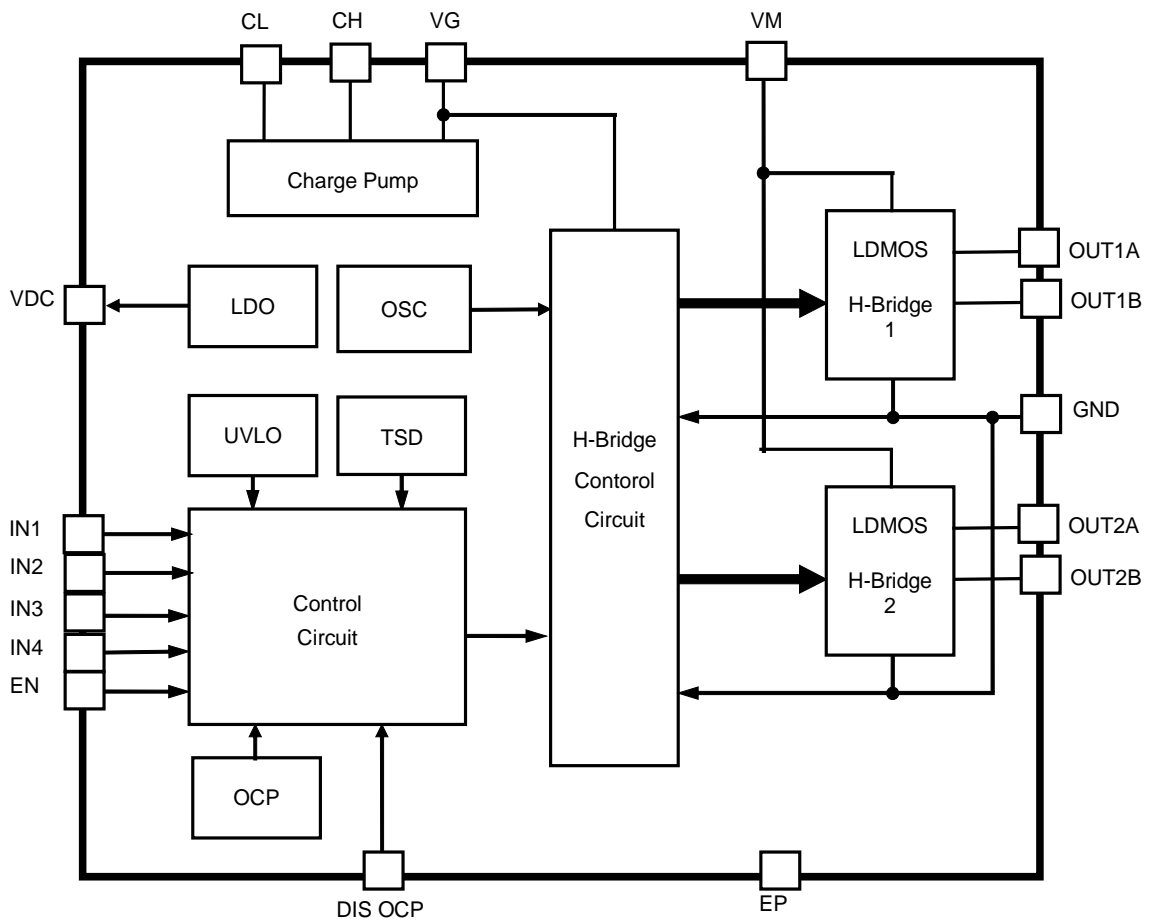
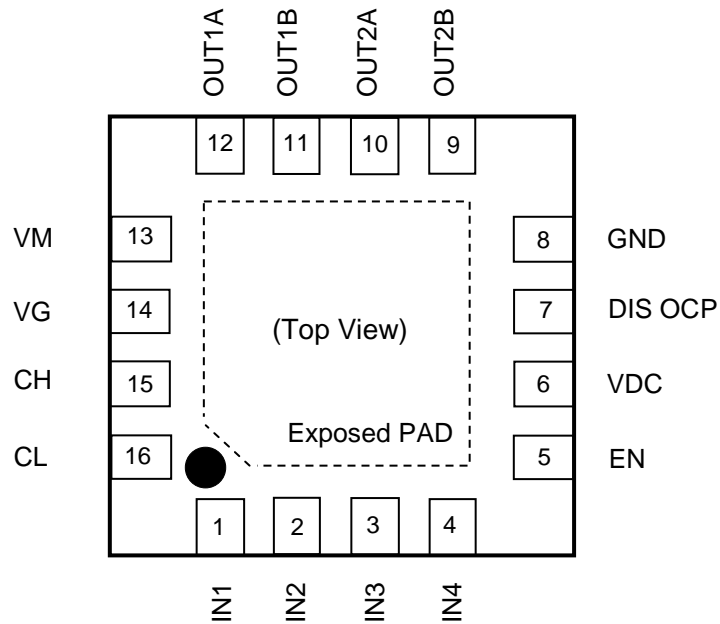

Figure 1. Block Diagram

5. Pin Configurations and Functions

5.1 Pin Configurations



5.2 Functions

Pin Number	Pin Name	I/O	Functions	Notes
1	IN1	I	Control Signal Input	Built-in 200kΩ Pull-down
2	IN2	I	Control Signal Input	Built-in 200kΩ Pull-down
3	IN3	I	Control Signal Input	Built-in 200kΩ Pull-down
4	IN4	I	Control Signal Input	Built-in 200kΩ Pull-down
5	EN	I	Enable Signal Input	Built-in 200kΩ Pull-down
6	VDC	O	Coupling terminal for internal power supply	Connect a 1.0 μF capacitor between VDC pin and GND.
7	DIS OCP	I	Over current protection function terminal	Built-in 200kΩ Pull-down
8	GND	P	Ground	
9	OUT2B	O	Motor Driver Output	
10	OUT2A	O	Motor Driver Output	
11	OUT1B	O	Motor Driver Output	
12	OUT1A	O	Motor Driver Output	
13	VM	P	Motor Power Supply	
14	VG	I/O	Connect Terminal for Stabilizing Capacitor.	
15	CH	I/O	Connect Terminal for Charge Pump Capacitor.	
16	CL	I/O	Connect Terminal for Charge Pump Capacitor.	
EP	EP	P	Ex-posed Pad	(Note 2)

Note 1. I(Input pin)、O(Output pin)、P(Power pin)、I/O(Input/Output pin)

Note 2. Exposed PAD must be connected to GND.

6. Absolute maximum Ratings

Parameter	Symbol	min	max	Unit	Condition
Motor Operating Voltage	VM	-0.3	19	V	
Input Terminal Voltage 1 (IN1, IN2, IN3, IN4, EN)	Vterm1	-0.3	6.0	V	
Input Terminal Voltage 2 (DIS OCP)	Vterm2	-0.3	V _{DC}	V	
VM Level Terminal Voltage (OUTnA, OUTnB)	Vterm3	-0.3	VM	V	
CH, VG Terminal Voltage	Vterm4	-0.3	24	V	
VDC Terminal Voltage	VDC	-0.3	6.0	V	
CL Terminal Voltage	VCL	-0.3	V _{DC}	V	
Maximum Output Current	Iload	-	0.7	A	Ta=25°C, 1ch (Note 4)
		-	0.5	A	Ta=85°C, 1ch (Note 4)
		-	0.5	A/ch	Ta=25°C, 2ch simultaneously (Note 4)
		-	0.35	A/ch	Ta=85°C, 2ch simultaneously (Note 4)
Power Dissipation	PD	-	1.83	W	Ta=25°C (Note 4, Note 5)
Junction Temperature	Tj	-	150	°C	
Storage Temperature	Tstg	-40	150	°C	

Note 3. All voltages are for GND = 0V.

Note 4. For Power Dissipation, the output current rating may be limited by duty cycle, Ta, and PCB board heat sinking design.

Note 5. A 2-layer board is used. R_{θJA} = 60°C/W.

WARNING: Operation at or beyond these limits may result in permanent damage to the device. Normal operation is not guaranteed at these extremes.

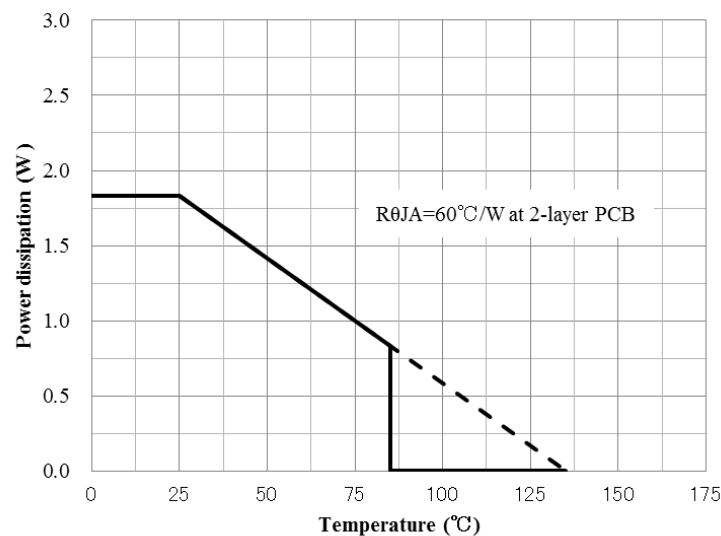

Figure 2. Maximum Power Dissipation

7. Recommended Operating Conditions

(Ta=25°C, unless otherwise specified.)

Parameter	Symbol	min	typ	max	Unit
Motor Operating Voltage	VM	6.0	12	18	V
Logic Terminal Voltage	VIO	0		5.5	V
Input Frequency Range	F _{in}	-	-	200	kHz
Operating Temperature Range	Ta	-30	-	85	°C

8. Electrical Characteristics

(Ta=25°C, VM=12V, unless otherwise specified.)

Parameter	Symbol	Condition	min	typ	max	Unit
Quiescent Current						
VM Quiescent Current at the time of Power Save	I _{VMOFF}	IN=All "L", EN="L"	-	-	10	μA
VM Quiescent Current at the time of Operating	I _{VM}	IN1=IN3="H"/"L" 200kHz, IN2=IN4="L"/"H" 200kHz, EN="H", Open between OUTA and OUTB	-	1.8	3.0	mA
Charge Pump						
Charge Pump Voltage	VG	VG=VM+V _{DC} , I _{load} =0A	-	-	17	V
Charge Pump Rise Time	t _{VGON}	EN="L"→"H", C _{VG} =0.1μF	-	0.6	3.0	ms
H-Bridge						
Driver on resistance (H-Bridge High+Low)	R _{ON}	I _{load} (1ch/2ch) = 0.1A/0.1A	-	1.1	1.7	Ω
H-Bridge Driver Body diode forward voltage	V _F	I _F = 100mA	-	0.8	1.2	V
Delay Time						
Output Delay Time ("L"→"H")	t _{PDLH}	Connected to 1kΩ between OUTA and OUTB. (Figure 3)	-	-	1.0	μs
Output Delay Time ("H"→"L")	t _{PDHL}		-	-	1.0	μs
Output Pulse Width	t _{PW}	Connected to 1kΩ between OUTA and OUTB. Input Pulse Width : 1μs (Figure 3)	0.5	1.0	1.5	μs
Control Logic						
VDC Terminal Voltage	V _{DC}		4.2	4.65	5.0	V
Input High Level Voltage	V _{IH}		2.0	-	-	V
Input Low Level Voltage (EN)	V _{IL1}		-	-	0.4	V
Input Low Level Voltage (IN1, IN2, IN3, IN4, DIS OCP)	V _{IL2}		-	-	0.6	V
Input Pulse Rise Time	t _R		-	-	1.0	μs
Input Pulse Fall Time	t _F		-	-	1.0	μs
Pull-down resistance	R _{PD}		100	200	300	kΩ
Input Low Level Current	I _{IL}		-1.0	-	1.0	μA
Protection Circuit						
Under Voltage Detect Voltage	VM _{UV}		3.85	4.3	4.65	V
Thermal Shutdown Temperature (Note 7)	T _{TSD}		135	155	175	°C
Temperature Hysteresis (Note 7)	T _{TSDHYS}		-	30	-	°C
Overcurrent protection	I _{OCP}	DIS OCP="L"	1.3	2.6	3.9	A

Note 6. All above voltage is defined to GND=0V.

Note 7. Not tested under mass-production.

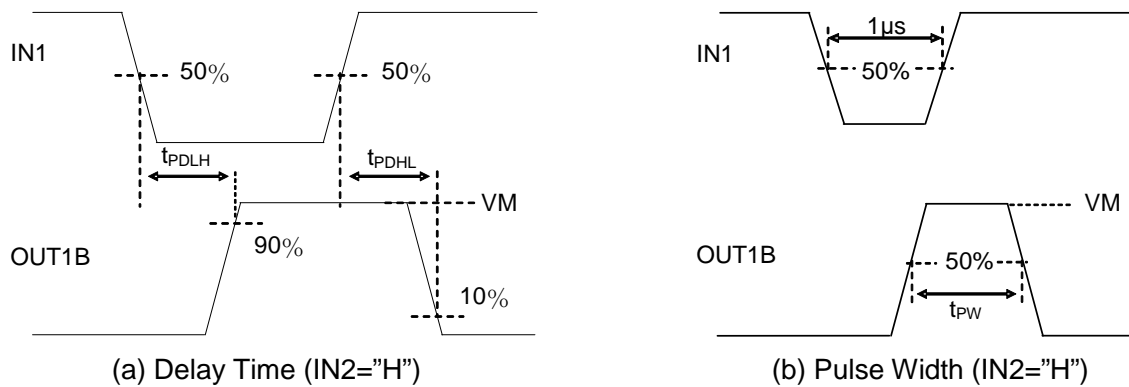

Figure 3. Timing Chart (Delay Time, Pulse Width)

9. Functional Descriptions

9.1 Operation Outline

Table 1. The relationship between input and output in each mode is as follows.

INPUT					OUTPUT				Mode
EN	IN1	IN2	IN3	IN4	OUT1A	OUT1B	OUT2A	OUT2B	
L	-	-	-	-	Hi-Z	Hi-Z	Hi-Z	Hi-Z	Power Save(Note 8)
H	L	L	-	-	Hi-Z	Hi-Z	-	-	Standby
H	H	L	-	-	H	L	-	-	CW
H	L	H	-	-	L	H	-	-	CCW
H	H	H	-	-	L	L	-	-	Brake
H	-	-	L	L	-	-	Hi-Z	Hi-Z	Standby
H	-	-	H	L	-	-	H	L	CW
H	-	-	L	H	-	-	L	H	CCW
H	-	-	H	H	-	-	L	L	Brake

Note 8. Charge Pump Block and TSD, UVLO, OCP don't operate at the Power Save.

Note 9. After inputting "H" to the EN pin, input "H or L" to IN 1 - 4 pin.

9.2 Motor Driver Block Configuration

The Nch LDMOS FET is placed on both sides of the high side and the low side in the output stage, making it possible to apply a small package. Hi-side FET is driven by VG. $V_G = V_M + V_{DC}$ is generated by the charge pump. Lo-side FET is driven by V_{DC} .

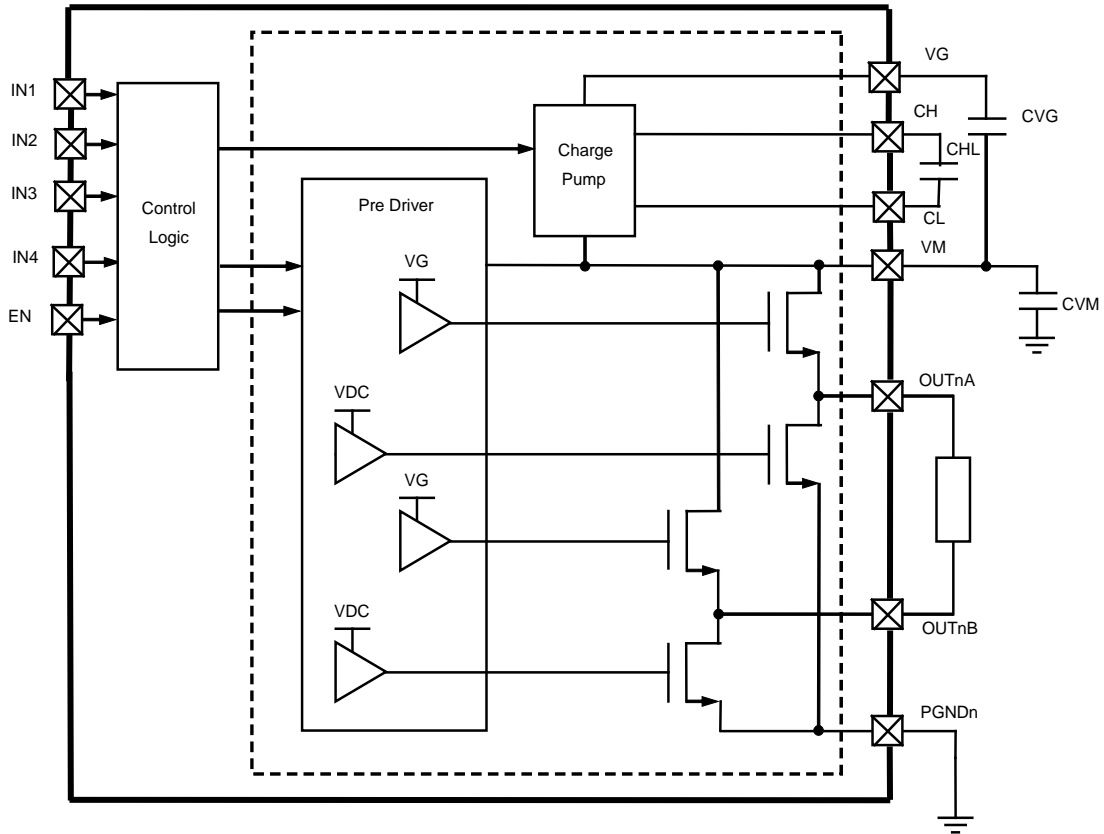

Figure 4. Driver Block Equivalent circuit

9.3 Protection Circuits

9.3.1 Under Voltage Lockout (UVLO)

If VM voltage is lower than 4.3V at the starting, the H-Bridge output is the Hi-Z.

9.3.2 Thermal Shutdown(TSD)

When the internal temperature of the IC reaches the specified temperature ($T_{TSD}=155^{\circ}\text{C}$), and the H-Bridge driver outputs Hi-Z. When the internal temperature after the detection is lowered about 30°C (T_{TSDHYS}), the driver resumes operation.

$$\text{Restart Temperature} = T_{TSD} - T_{TSDHYS}$$

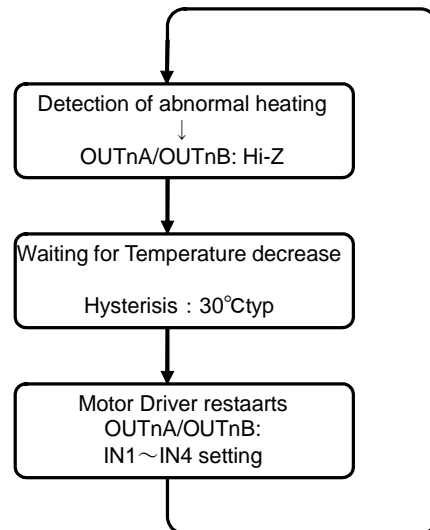

Figure 5. Detection of abnormal heating

9.3.3 Over current protection (OCP)

When the current of 2.6 A or more continues to flow to the H - Bridge driver for 10 μs , all H - Bridge driver outputs are set to Hi - Z, and automatically return after 200 ms.

Over current protection circuit can be used by setting the DIS OCP terminal to L level. When not using the overcurrent protection circuit, connect the DIS OCP terminal to the VDC terminal.

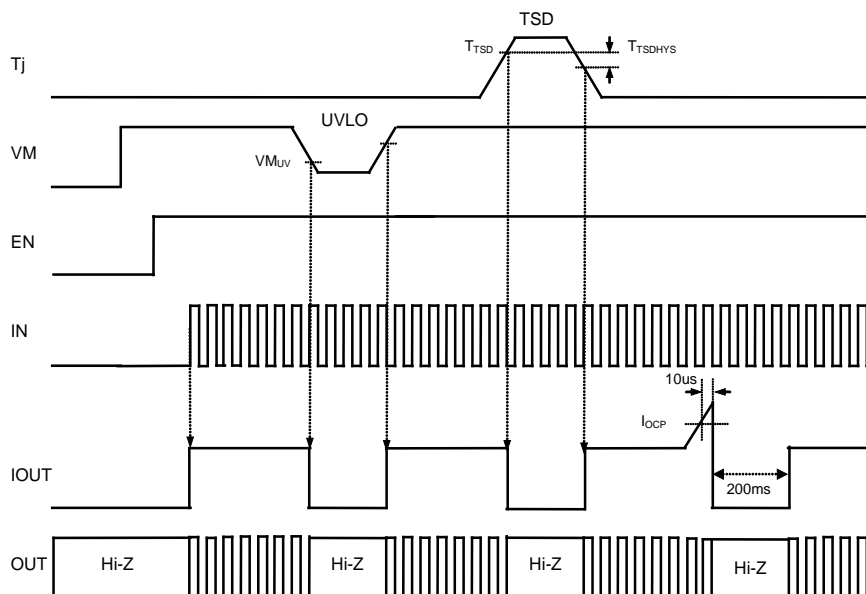
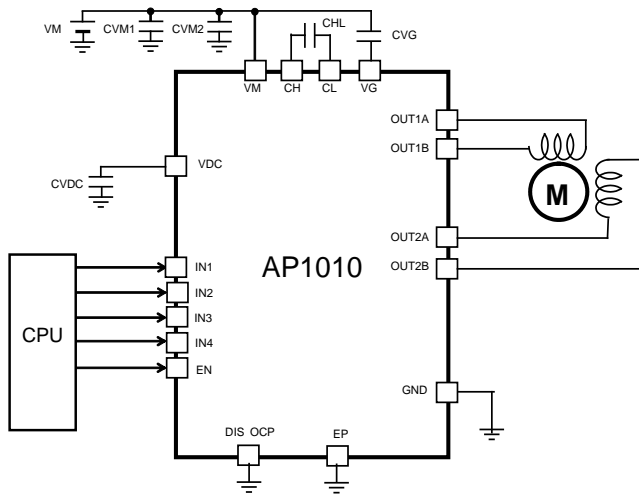

Figure 6. Protection Function Timing Chart

10. Recommended External Circuits

■ Driving Stepper Motor



■ Driving DC Motor

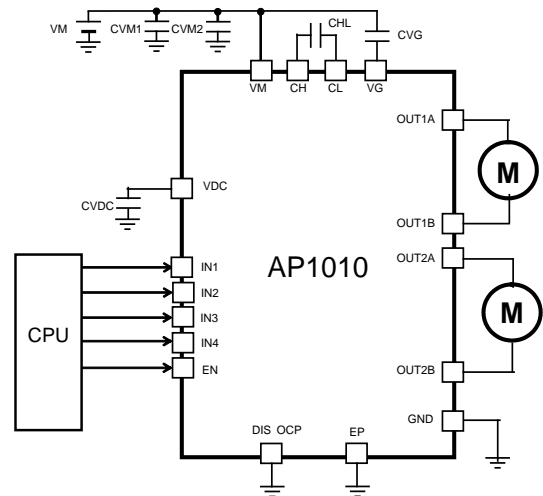

Figure 7. Recommended External Circuits

Table 2. Parts List

Items	Symbol	min	typ	max	Unit	Note
Motor driver power connection capacity(Decoupling capacitor)	CVM1	-	10	-	μF	(Note 10)
	CVM2	-	1	-	μF	
Charge pump capacity	CHL	0.047	0.1	0.22	μF	
	CVG	0.047	0.1	0.22	μF	
Internal power connection capacity (Decoupling capacitor)	CVDC	0.47	1.0	2.2	μF	

Note 10. Capacitance of CVM should be determined in consideration of the load current profile, the load capacitance, the line resistance and etc. of the actual system board.

Note 11. Please layout the large ground plane on the PCB.

Note 12. Please connect the exposed pad (heat sink) to the ground of the PCB.

11. Package

11.1 Outline Dimensions

• 16-pin QFN (Unit : mm)

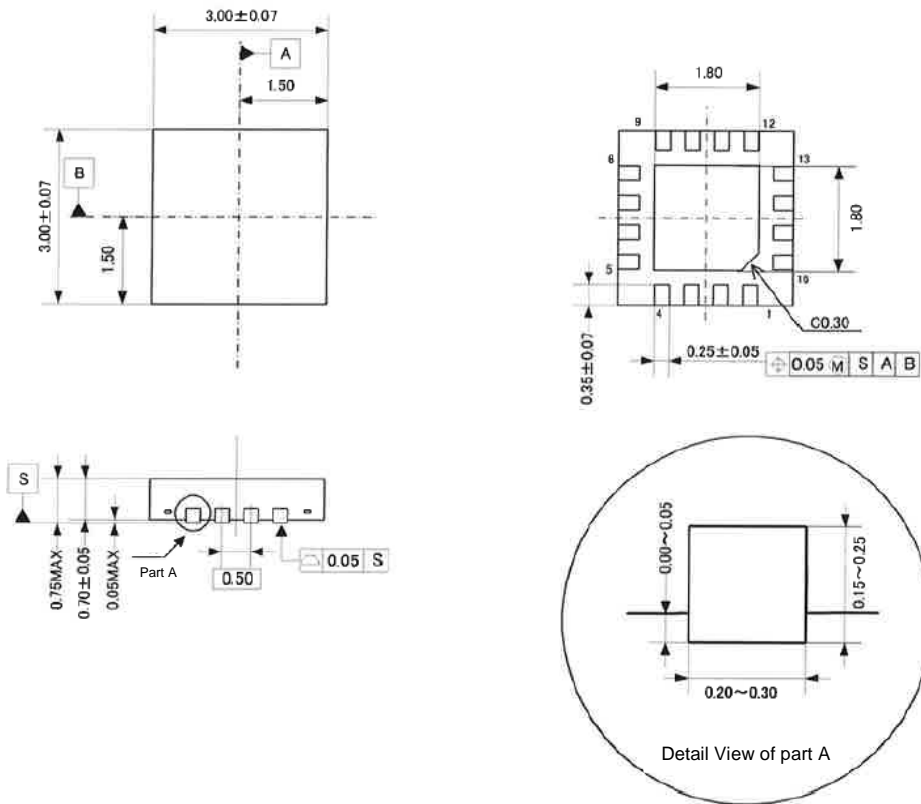

11.2 Recommended Land Pattern

• 16-pin QFN (Unit : mm)

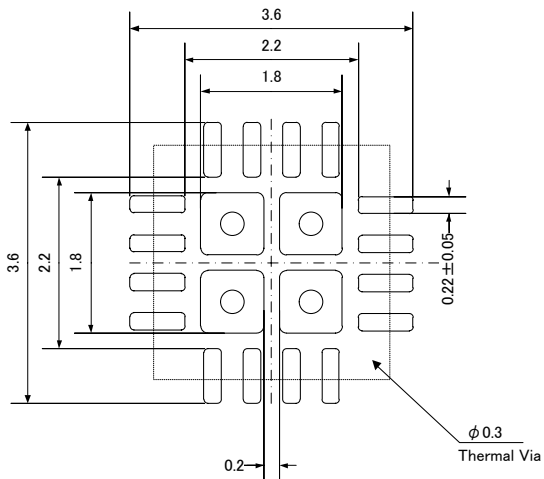

The optimum dimensions of the mount pad will vary depending on the substrate material, solder paste method, device accuracy, etc. In actual design, please optimize according to the situation.

11.3 Marking

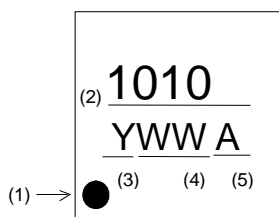

- (1) 1pin Indication
- (2) Market No.
- (3) Year code (last 1 digit)
- (4) Week code
- (5) Management code

12. Ordering Guide

AP1010AEN

-30°C~85°C

16-pin QFN

13. Revise History



Date (YY/MM/DD)	Revision	Page	Contents
17/07/11	00	-	First Edition
17/11/01	01	5	Correction of mistake in Note 5. A 4-layer board is used.→A 2-layer board is used.

IMPORTANT NOTICE



0. Asahi Kasei Microdevices Corporation ("AKM") reserves the right to make changes to the information contained in this document without notice. When you consider any use or application of AKM product stipulated in this document ("Product"), please make inquiries the sales office of AKM or authorized distributors as to current status of the Products.
1. All information included in this document are provided only to illustrate the operation and application examples of AKM Products. AKM neither makes warranties or representations with respect to the accuracy or completeness of the information contained in this document nor grants any license to any intellectual property rights or any other rights of AKM or any third party with respect to the information in this document. You are fully responsible for use of such information contained in this document in your product design or applications. AKM ASSUMES NO LIABILITY FOR ANY LOSSES INCURRED BY YOU OR THIRD PARTIES ARISING FROM THE USE OF SUCH INFORMATION IN YOUR PRODUCT DESIGN OR APPLICATIONS.
2. The Product is neither intended nor warranted for use in equipment or systems that require extraordinarily high levels of quality and/or reliability and/or a malfunction or failure of which may cause loss of human life, bodily injury, serious property damage or serious public impact, including but not limited to, equipment used in nuclear facilities, equipment used in the aerospace industry, medical equipment, equipment used for automobiles, trains, ships and other transportation, traffic signaling equipment, equipment used to control combustions or explosions, safety devices, elevators and escalators, devices related to electric power, and equipment used in finance-related fields. Do not use Product for the above use unless specifically agreed by AKM in writing.
3. Though AKM works continually to improve the Product's quality and reliability, you are responsible for complying with safety standards and for providing adequate designs and safeguards for your hardware, software and systems which minimize risk and avoid situations in which a malfunction or failure of the Product could cause loss of human life, bodily injury or damage to property, including data loss or corruption.
4. Do not use or otherwise make available the Product or related technology or any information contained in this document for any military purposes, including without limitation, for the design, development, use, stockpiling or manufacturing of nuclear, chemical, or biological weapons or missile technology products (mass destruction weapons). When exporting the Products or related technology or any information contained in this document, you should comply with the applicable export control laws and regulations and follow the procedures required by such laws and regulations. The Products and related technology may not be used for or incorporated into any products or systems whose manufacture, use, or sale is prohibited under any applicable domestic or foreign laws or regulations.
5. Please contact AKM sales representative for details as to environmental matters such as the RoHS compatibility of the Product. Please use the Product in compliance with all applicable laws and regulations that regulate the inclusion or use of controlled substances, including without limitation, the EU RoHS Directive. AKM assumes no liability for damages or losses occurring as a result of noncompliance with applicable laws and regulations.
6. Resale of the Product with provisions different from the statement and/or technical features set forth in this document shall immediately void any warranty granted by AKM for the Product and shall not create or extend in any manner whatsoever, any liability of AKM.
7. This document may not be reproduced or duplicated, in any form, in whole or in part, without prior written consent of AKM.

Looking for pricing, stock, or lifecycle information?

Click below to explore more details on WIN SOURCE:

-  [View AP1010AEN on WIN SOURCE](#)
-  [Asahi Kasei Microsystems Information](#)

Optimize Your Supply Chain with WIN SOURCE Solutions

-  Global Sourcing Solution
-  Obsolete Management
-  Cost Control Management
-  Shortage Management
-  Alternative Solution
-  Excess Inventory Management