



**THE DATASHEET OF
AOZ1380DI**



General Description

AOZ1380DI integrates two back-to-back power switches and control circuitry into one single package to provide all the functionality and protection needed for sourcing and sinking current through a USB Type-C port with PD capability. The device can sink current from the Type-C port through a back-to-back MOSFET with only 20mΩ ON resistance from VBUS to VCHG pin. The VBUS operating range is from 3.4V to 22V under sink mode with absolute maximum rating of 28V on both VBUS and VCHG pins. There is under-voltage lockout (UVLO) and over-voltage lockout (OVLO) on VBUS. The sink switch has an active low enable input to support dead battery operation and its soft-start is adjustable through an external capacitor through the SS pin.

AOZ1380DI also offers a current-sourcing path from 5V power supply to VBUS through a separate back-to-back MOSFET with 39mΩ ON resistance. The input operating range at V5V pin is from 3.4V to 5.5V. The sourcing switch is also protected by UVLO and OVLO. There is internal soft-start to control inrush current. The current limit can be adjusted from 500mA to 3.5A with an external resistor. The device has short circuit protection that shuts off the switch quickly to prevent input droop and system brown out. The sourcing switch also features a FON pin for fast turn-on capability to support the Fast Role Swap (FRS) function.

AOZ1380DI has True Reverse Current Blocking (TRCB) function in both sink and source modes. The back-to-back MOSFET automatically prevents reverse current when the output voltage exceeds the input voltage. The device is also protected by thermal shutdown. There are two FLT flags, FLT_SNK for sink mode and FLT_SRC for source mode, which are open drain outputs and each will be pulled low independently for fault condition.

AOZ1380DI is available in a 3mm x 5.2mm DFN-20L package and can operate from -40°C to +85°C temperature range.

Features

- 10A Sink Continuous Current
- 20A Sink Pulsed Current(10ms @ 2% Duty Cycle)
- Support Type-C PD sink and source mode
- 3mm x 5.2mm DFN-20L package
- Thermal shutdown protection
- IEC 61000-4-2 ±8kV on VBUS
- IEC 61000-4-5 40V on VBUS (no cap)
- ±2.5kV HBM rating
- ±1kV CDM rating
- IEC 62368-1
- Sink Switch Features:
 - 20mΩ ON resistance
 - 3.4V to 22V operating voltage
 - VBUS and VCHG rated 28V
 - True Reverse Current Blocking (TRCB)
 - Programmable Over-Voltage Protection (OVP)
 - Under Voltage Lock Out (UVLO)
 - Programmable soft-start
 - Enable active low for dead battery operation
- Source Switch Features:
 - 39mΩ ON resistance
 - FRS (Fast Role Swap) support
 - 3.4V to 5.5V operating voltage
 - True Reverse Current Blocking (TRCB)
 - Programmable current limit (OCP)
 - Internal soft-start
 - Enable active high

Applications

- Thunderbolt/USB Type-C PD power switch
- Portable devices
- Notebooks
- Ultrabooks



Typical Application

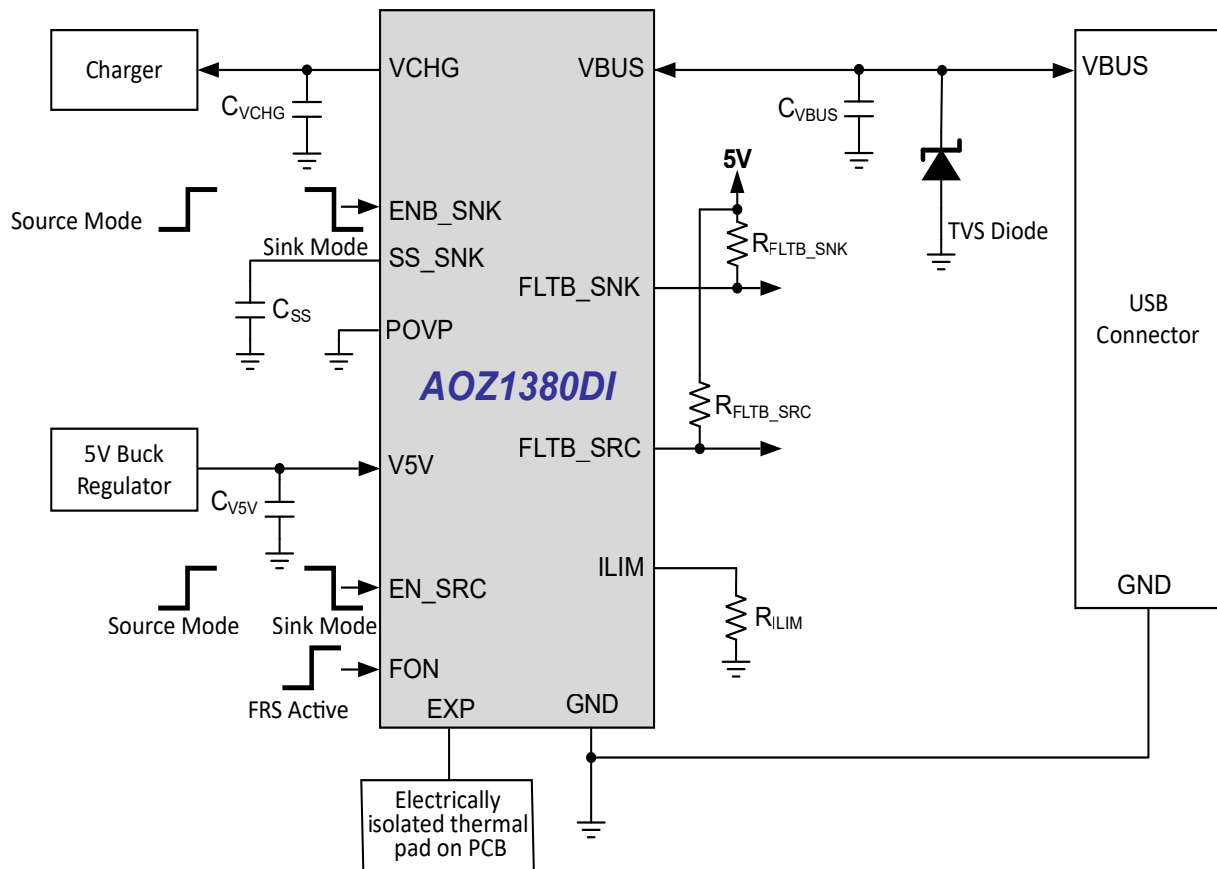

Ordering Information

Part Number	Fault Recovery	Temperature Range	Package	Environmental
AOZ1380DI-01	Auto-Recovery	-40°C to +85°C	DFN3x5.2-20L	RoHS
AOZ1380DI-02*	Latch-Off	-40°C to +85°C	DFN3x5.2-20L	RoHS

* (contact sales)



AOS Green Products use reduced levels of Halogens, and are also RoHS compliant. Please visit www.aosmd.com/media/AOSGreenPolicy.pdf for additional information.

Pin Configuration

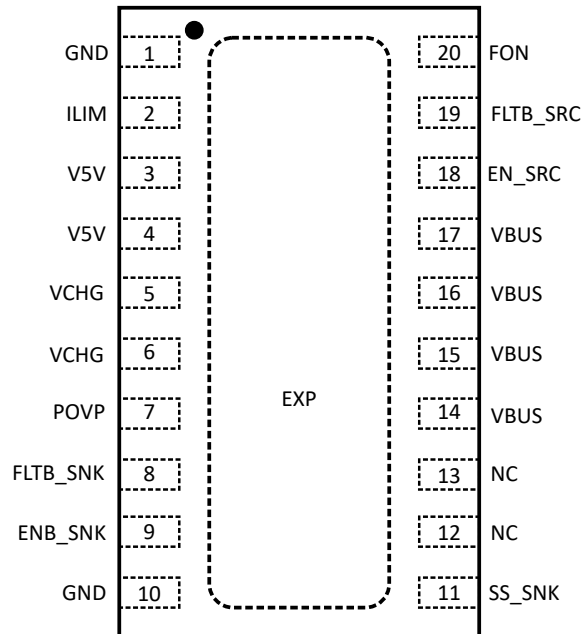

Figure 1. DFN3x5.2-20L
(Top Transparent View)

Pin Description

Pin Number	Pin Name	Pin Function
1, 10	GND	Ground connection
2	ILIM	Current limit setting for Source mode. Connect a resistor to this pin to set the threshold of current limit.
3,4	V5V	Source mode power input from 5V power bus
5,6	VCHG	Sink mode power output to battery charger
7	POVP	Over voltage setting for Sink mode. Connect this pin to GND to set the threshold to 24V. Leave floating to set the threshold to 5.8V.
8	FLT_B_SNK	Open drain fault indicator for Sink mode. Connect a pull up resistor from this pin to 5V supply
9	ENB_SNK	Enable for Sink mode. Active low.
11	SS_SNK	Soft start slew rate control for Sink mode.
12, 13	NC	No Connect
14, 15, 16, 17	VBUS	Common power bus for VCHG and V5V. It is connected to VCHG for Sink mode or V5V for Source mode.
18	EN_SRC	Enable for Source function. Active high.
19	FLT_B_SRC	Open drain fault indicator for Source mode. Connect a pull up resistor from this pin to 5V supply.
20	FON	Fast Role Swap (FRS) function control for Source mode.
EXP	EXP	Exposed Thermal Pad. It is the common drain node of the internal back-back sink switches and it must be electrically isolated. Solder to a metal surface directly underneath EXP and connect to floating Cu thermal pads on multiple PCB layers through VIAs. For best thermal performance make the floating Cu pads as large as possible and connect to EXP with multiple VIAs

Absolute Maximum Ratings

Exceeding the Absolute Maximum ratings may damage the device.

Parameter	Rating
VBUS, VCHG to GND	-0.3V to 28V
V5V to GND	-0.3V to 6V
Control Inputs ENB_SNK, EN_SRC, SS_SNK, POVP, ILIM, FON to GND	-0.3V to 6V
Outputs FLTB_SNK, FLTB_SRC to GND	-0.3V to 6V
Junction Temperature (T_J)	+150°C
Storage Temperature (T_S)	-65°C to +150°C
ESD Rating HBM/CDM	±2.5kV / ±1kV
IEC 61000-4-2 on VBUS	+/-8kV

Recommended Operating Conditions

The device is not guaranteed to operate beyond the Maximum Recommended Operating Conditions.

Parameter	Rating
VBUS, VCHG to GND	3.4V to 22V
V5V to GND	0 to 5.5V
Control Inputs ENB_SNK, EN_SRC, SS_SNK, ILIM, FON to GND	0 to 5.5V
Outputs FLTB_SNK, FLTB_SRC to GND	0 to 5.5V
POVP to GND	0 to 3V
Sink Switch DC Current (I_{SW_SNK})	0A to 10A
Peak Sink Switch Current (I_{SW_PK}) 10ms @ 2% Duty Cycle	20A
Source Switch DC Current (I_{SW_SRC})	0A to 3.5A
Ambient Temperature (T_A)	-40°C to +85°C
Package Thermal Resistance (AOS Evaluation Board) 3x5.2 DFN-20L (Θ_{JA})	36°C/W

Electrical Characteristics for Sink Mode Switch

$T_A = 25^\circ\text{C}$, $V_{BUS} = 20\text{V}$, $FON = 0\text{V}$, $ENB_SNK = 0\text{V}$, $EN_SRC = 0\text{V}$, $POVP = \text{GND}$, unless otherwise specified.

Symbol	Parameter	Conditions	Min	Typ	Max	Unit
General						
V_{BUS}	Input Supply Voltage		3.4		22	V
V_{UVLO_SNK}	Under-Voltage Lockout Threshold	VBUS Rising	3.0	3.25	3.35	V
$V_{UVLO_SNK_HYS}$	Under-Voltage Lockout Hysteresis	VBUS Falling		0.25		V
$I_{VBUS_ON_SNK}$	Input Quiescent Current	VBUS = 20V. $I_{VCHG} = 0\text{A}$		575		μA
$I_{VBUS_OFF_SNK}$	Input Shutdown Current	VBUS = 20V. $I_{VCHG} = 0\text{A}$. $ENB_SNK = 5\text{V}$		26		μA
I_{VCHG_OFF}	Output Leakage Current	VCHG = 20V. VBUS = 0V. $ENB_SNK = 5\text{V}$		24		μA
R_{ON_SNK}	Switch ON Resistance	VBUS = 20V. $I_{VBUS} = 1\text{A}$.		20		m Ω
Enable and Fault Logic						
$V_{ENB_SNK_H}$	Enable Input High Voltage	ENB_SNK rising	1.4			V
$V_{ENB_SNK_L}$	Enable Input Low Voltage	ENB_SNK falling			0.6	V
I_{ENB_SNK}	Enable Input Bias Current	ENB_SNK = 1.8V			10	μA
V_{FLT_SNK}	Fault pull-down voltage	$I_{SINK} = 3\text{mA}$			0.3	V
Over-Voltage Protection						
V_{OVLO_SNK}	Overvoltage Lockout Threshold	$POVP = \text{GND}$. VBUS rising	23	24	25	V
		$POVP = \text{OPEN}$. VBUS rising	5.5	5.8	6	V
$V_{OVLO_SNK_HYS}$	Overvoltage Lockout Hysteresis	VBUS falling		300		mV
$t_{DELAY_OVP_SNK}$	Overvoltage Turn-off Delay	From VBUS $\geq V_{OVLO_SNK}$ to switch turns off		1		μs
True Reverse Current Blocking (TRCB)						
V_{TRCB_SNK}	TRCB Threshold	VCHG-VBUS		26		mV
t_{TRCB_SNK}	TRCB delay Time	VCHG-VBUS $\geq V_{TRCB_SNK}$ to switch turns off		500		ns
Dynamic						
$t_{DLY_ON_SNK}$	Turn-On Delay Time	ENB_SNK to VCHG at 10% of VBUS, $C_{CHG} = 68\mu\text{F}$, $C_{SS} = 5.6\text{nF}$		20		ms
t_{ON_SNK}	Turn-On Rise Time	VCHG rising from 10% to 90% of VBUS, $C_{CHG} = 68\mu\text{F}$, $C_{SS} = 5.6\text{nF}$		1.9		ms
t_{REC}	Auto Restart Interval			64		ms

Electrical Characteristics for Source Mode Switch

$T_A = 25^\circ\text{C}$, $V_{5V} = 5\text{V}$, $FON = 0\text{V}$, $ENB_SNK = 5\text{V}$, $EN_SRC = 5\text{V}$, $R_{LIM} = 14.3\text{k}\Omega$ unless otherwise specified.

Symbol	Parameter	Conditions	Min	Typ	Max	Unit
General						
V_{V5V}	Input Supply Voltage		3.4		5.5	V
V_{UVLO_SRC}	Under-Voltage Lockout Threshold	V5V Rising	3.0	3.25	3.35	V
$V_{UVLO_SRC_HYS}$	Under-Voltage Lockout Hysteresis	V5V Falling		200		mV
I_{V5V_ON}	Input Quiescent Current	V5V = 5V. IO _{UT} = 0A		125		μA
I_{V5V_OFF}	Input Shutdown Current	V5V = 5V, EN _{SRC} = 0V		6		μA
R_{ON_SRC}	Switch On Resistance	V5V = 5V. IO _{UT} = 1A		39		m Ω
Enable and Fault Logic						
$V_{EN_SRC_H}$	Enable Input Logic High Threshold	EN _{SRC} rising	1.4			V
$V_{EN_SRC_L}$	Enable Input Logic Low Threshold	EN _{SRC} falling			0.4	V
I_{EN_SRC}	Enable Input Bias Current	EN _{SRC} = 1.8V		1	1.5	μA
V_{FON_H}	Fast-On Input Logic High Threshold	FON rising	1.4			V
V_{FON_L}	Fast-On Input Logic Low Threshold	FON falling			0.4	V
I_{FON}	Fast-On Input Bias Current	FON = 1.8V		1.5	4	μA
V_{FLT_SRC}	Fault Pull-down voltage	ISINK = 3mA			0.3	V
Over-Voltage Protection						
V_{OVLO_SRC}	Overvoltage Lockout Threshold	V5V rising	5.7	5.9	6	V
$V_{OVLO_SRC_HYS}$	Overvoltage Lockout Hysteresis	V5V falling		250		mV
$t_{DELAY_OVP_SRC}$	Overvoltage Turn-off Delay			3.5		μs
Over-Current Protection						
I_{LIM}	Current Limit Threshold	VBUS = 5V, $R_{LIM} = 4.02\text{k}\Omega$	3.15	3.5	3.85	A
		VBUS = 5V, $R_{LIM} = 7.1\text{k}\Omega$	1.78	2	2.22	A
		VBUS = 5V, $R_{LIM} = 14.3\text{k}\Omega$	0.9	1	1.1	A
$t_{OCP_FLT_SRC}$	Over Current Protection Fault Delay Time	From $I_{OUT} \geq I_{LIM}$ to FLT _{SRC} pulled low		10		ms
True Reverse Current Blocking (TRCB)						
$V_{T_TRCB_SRC}$	TRCB Protection Trip Point	VBUS - V5V, VBUS rising		25		mV
$V_{R_TRCB_SRC}$	TRCB Protection Release Trip Point	V5V - VBUS, VBUS falling		40		mV
$V_{TRCB_SRC_HYS}$	TRCB Hysteresis	$V_{T_TRCB_SRC} + V_{R_TRCB_SRC}$		65		mV
t_{TRCB_SRC}	TRCB Response Time	$VBUS - V5V > V_{T_TRCB_SRC} + 500\text{mV}$		600		ns

Electrical Characteristics Common to Source Mode

$T_A = 25^\circ\text{C}$, $V_{5V} = 5\text{V}$, $F_{ON} = 0\text{V}$, $ENB_SNK = 5\text{V}$, $EN_SRC = 5\text{V}$, $R_{LIM} = 14.3\text{k}\Omega$ unless otherwise specified.

Symbol	Parameter	Conditions	Min	Typ	Max	Unit
Dynamic						
$t_{DLY_ON_SRC}$	Turn-On Delay Time (From $EN_SRC = V_{EN_SRC_H}$ to $VBUS = 0.5\text{V}$)	$R_{VBUS} = 100\Omega$, $C_{VBUS} = 1\mu\text{F}$		2.1		ms
t_{ON_SRC}	Turn-On Time ($VBUS$ from 0.5V to 4.5V)	$R_{VBUS} = 100\Omega$, $C_{VBUS} = 1\mu\text{F}$		2.7		ms
t_{FON}	Fast Turn-On Time (From $EN_SRC = V_{EN_SRC_H}$ to $VBUS = 4.75\text{V}$)	$FON = 5\text{V}$, $R_{VBUS} = 100\Omega$, $C_{VBUS} = 1\mu\text{F}$		50	100	μs
t_{S_FON}	Fast Turn-On Setup Time	Before $EN_SRC = V_{EN_SRC_H}$	100			μs
t_{H_FON}	Fast Turn-On Hold Time	After $EN_SRC = V_{EN_SRC_H}$	40			μs
Thermal Shutdown						
T_{SD}	Thermal Shutdown Threshold	Temperature rising		140		$^\circ\text{C}$
T_{SD_HYS}	Thermal Shutdown Hysteresis	Temperature falling		30		

Functional Block Diagram

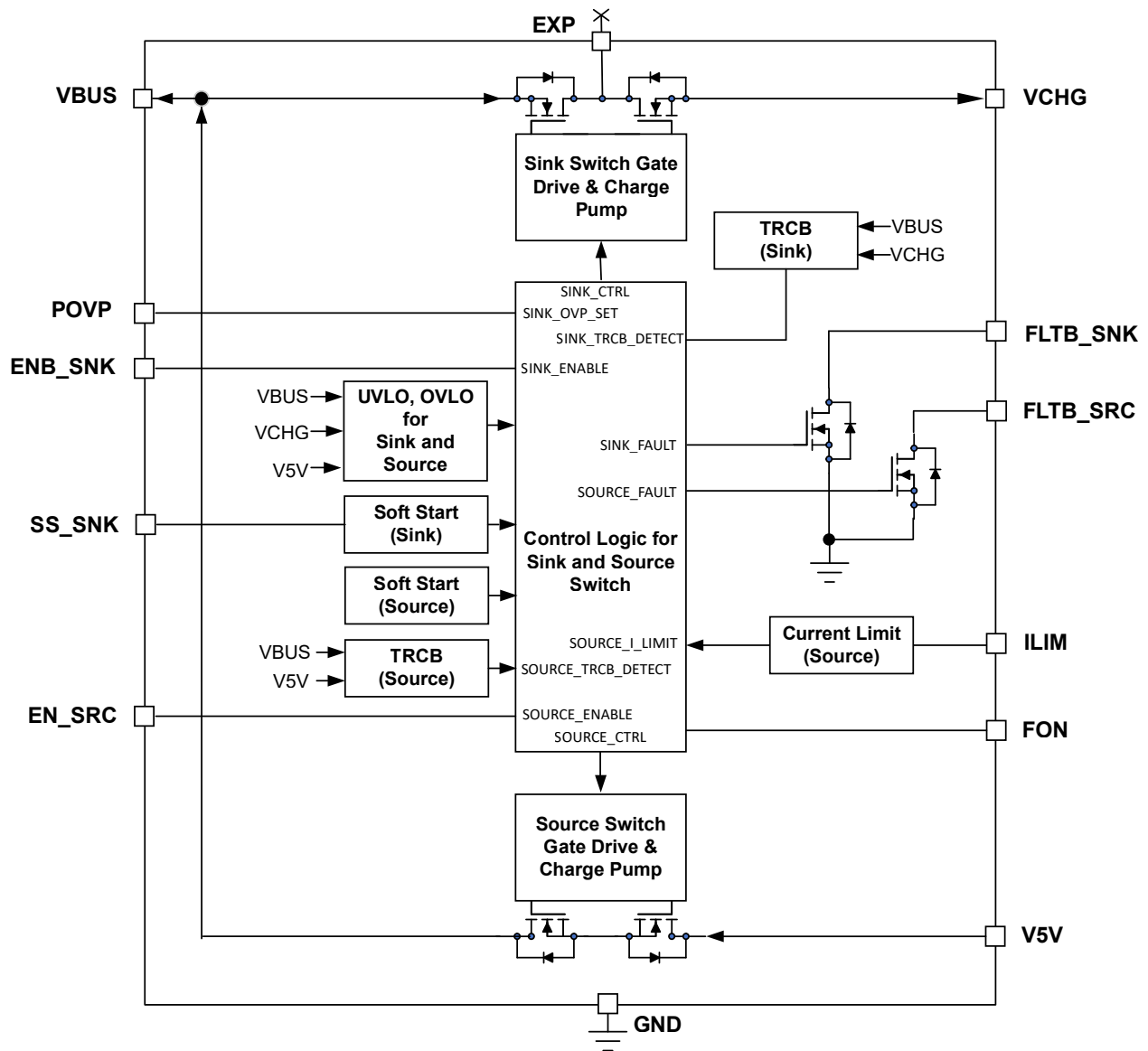

Figure 2. Functional Block Diagram

Timing Diagrams

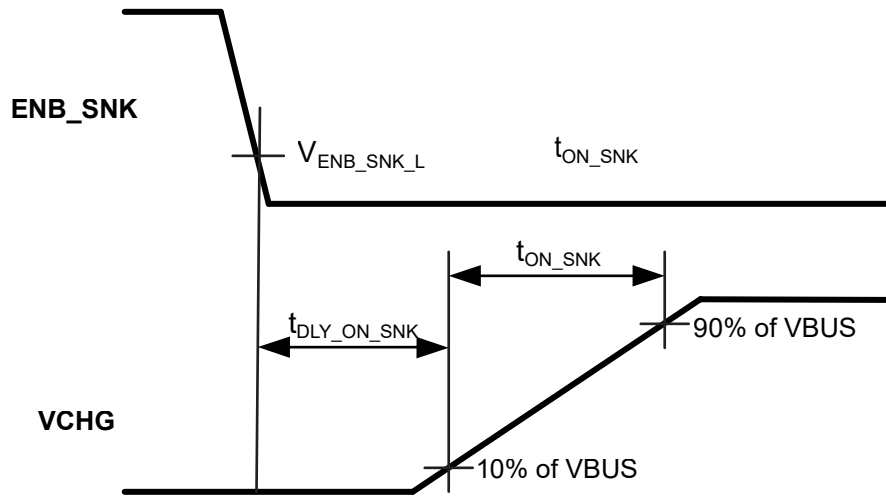

Figure 3. Turn On Delay and Turn On Time in Sink Mode

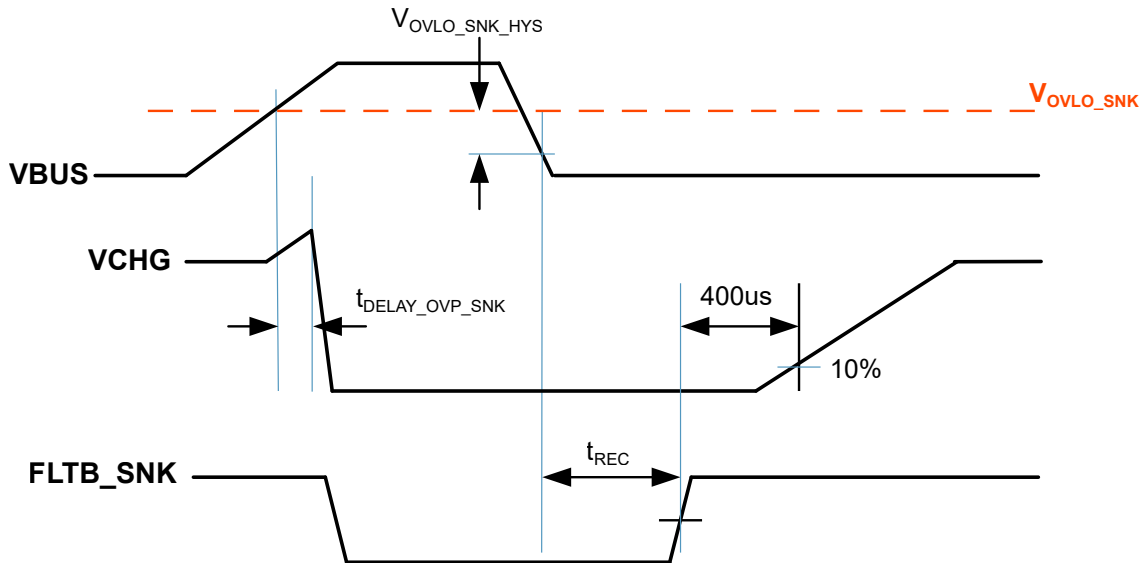

Figure 4. Over-Voltage Protection (OVP) Operation in Sink Mode

Timing Diagrams (Continued)

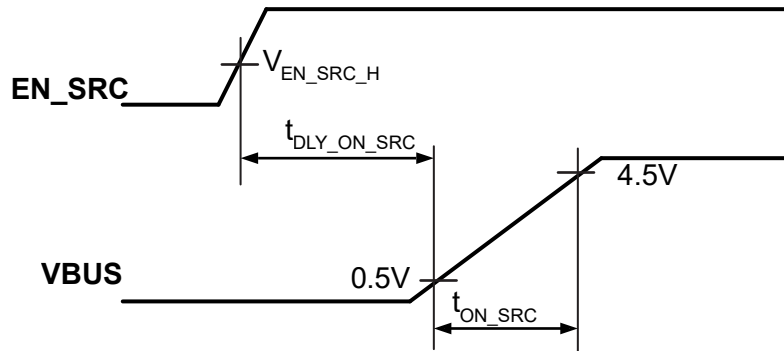

Figure 5. Turn On Delay and Turn On Time in Source Mode

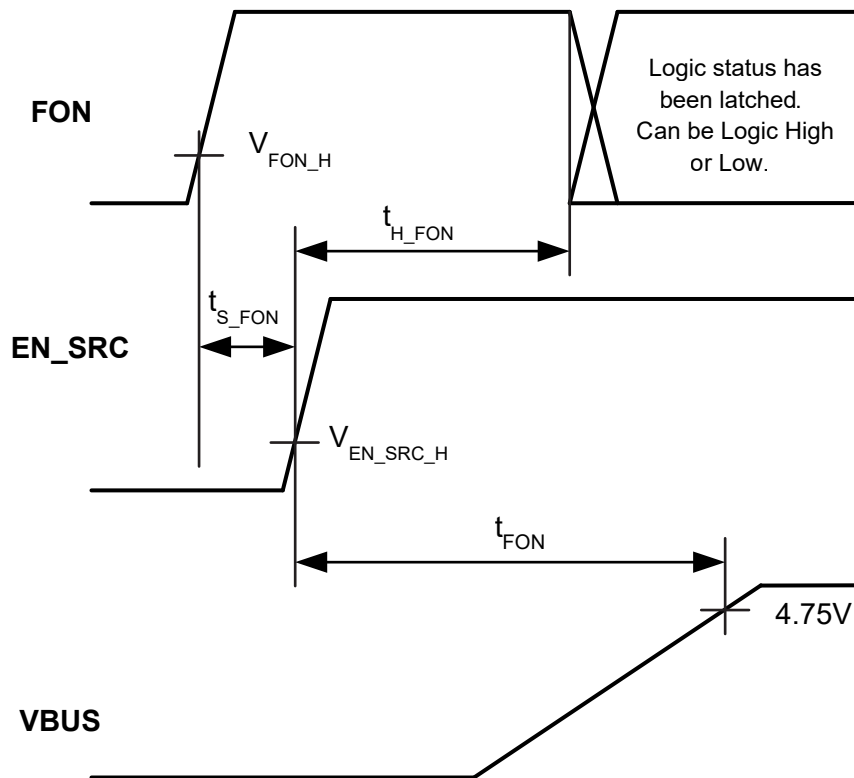

Figure 6. Turn On Time with Fast Role Swap (FRS) in Source Mode

Timing Diagrams (Continued)

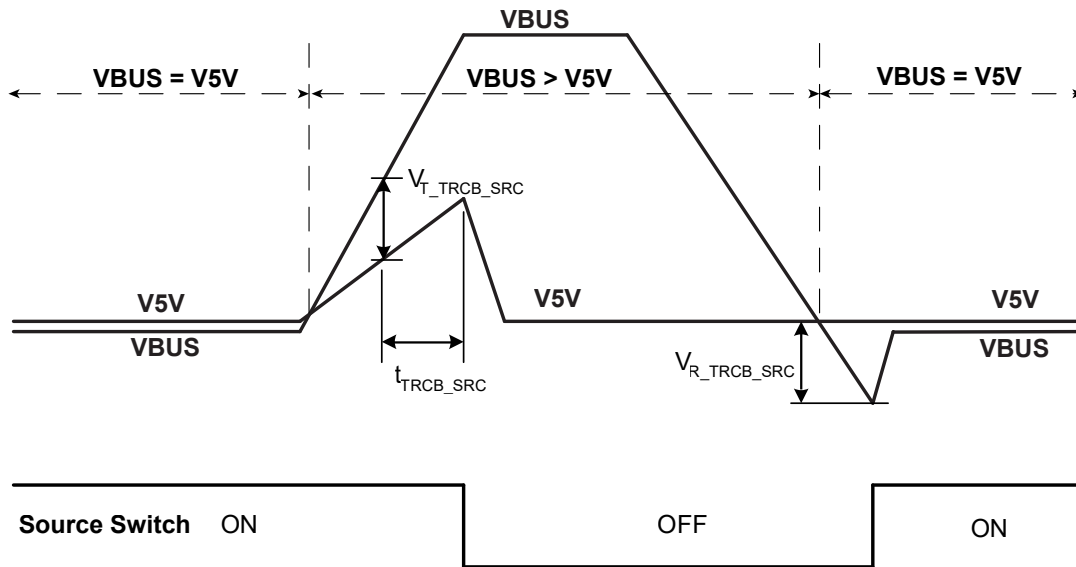

Figure 7. True Reverse Current Blocking (TRCB) Operation in Source Mode

Typical Characteristics for Sink Mode

$T_A = 25^\circ\text{C}$, $V_{BUS} = 20\text{V}$, $ENB_SNK = EN_SRC = 0\text{V}$, $C_{V_{BUS}} = 10\mu\text{F}$, $C_{V_{CHG}} = 120\mu\text{F}$, $C_{SS} = 5.6\text{nF}$, $POVP = \text{GND}$, no load, unless otherwise specified.

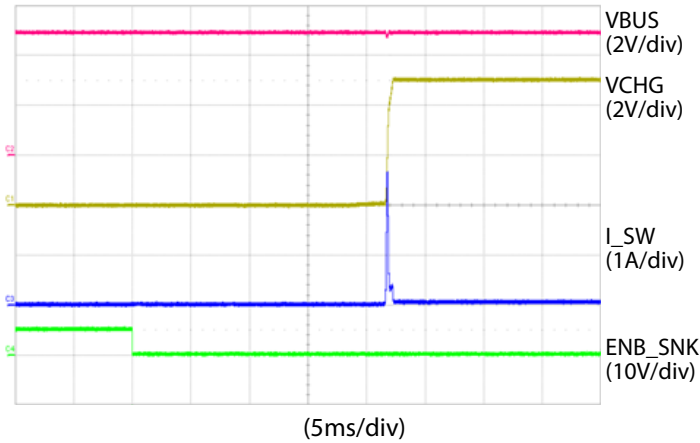

Figure 8. Sink Mode Soft Start Delay Time (VBUS = 5V)

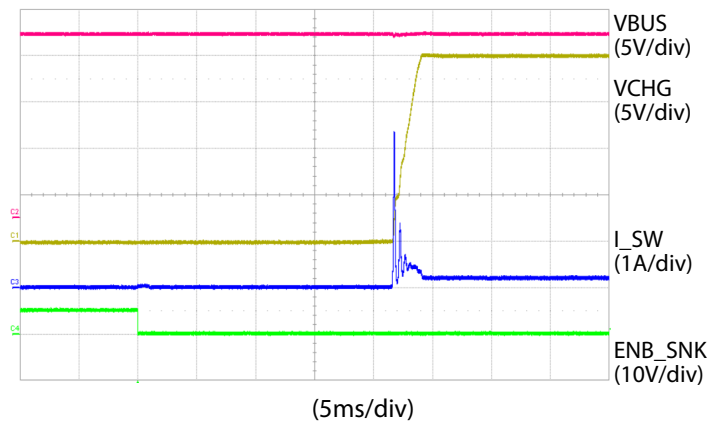

Figure 9. Sink Mode Soft Start Ramp (VBUS = 20V)

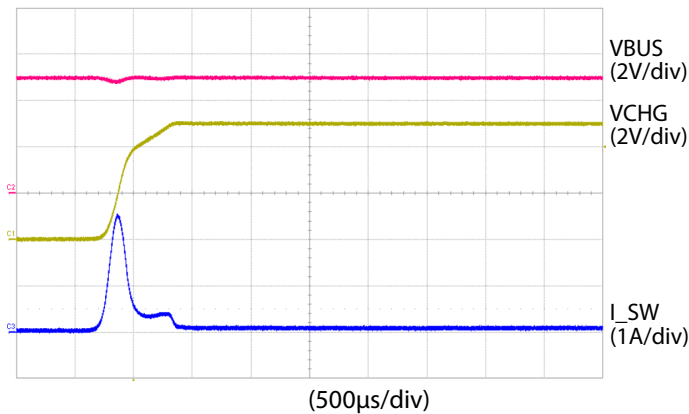

Figure 10. Sink Mode Soft Start Ramp (VBUS = 5V)

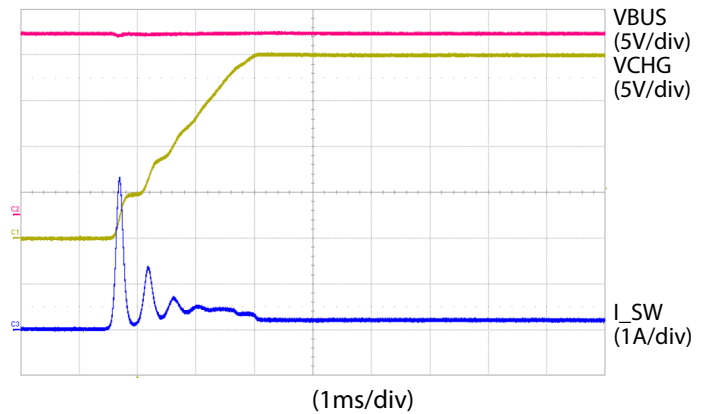

Figure 11. Sink Mode Soft Start Ramp (VBUS = 20V)

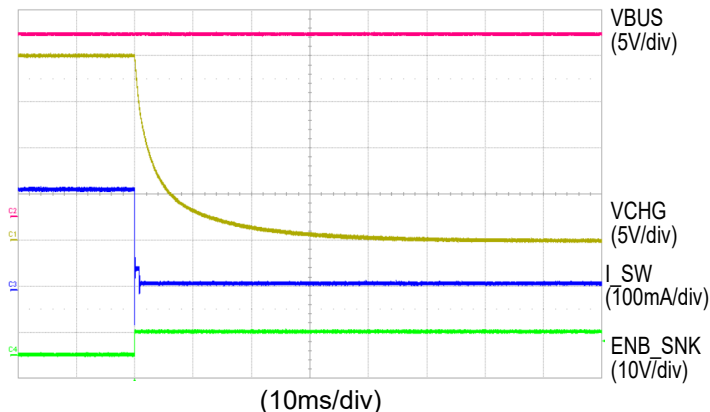

Figure 12. Sink Mode Shut Down

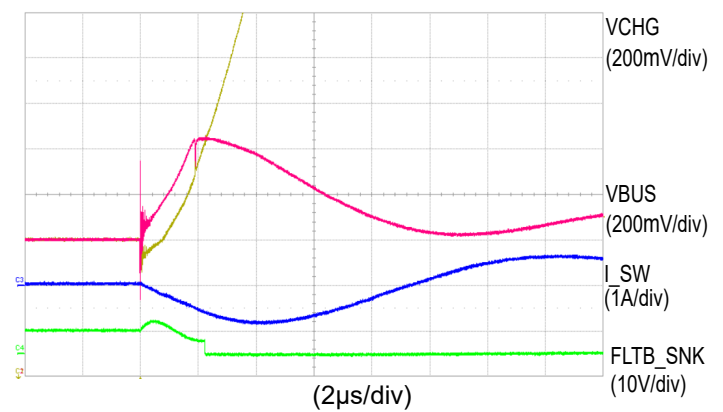

Figure 13. Sink Mode True Reverse Current Blocking (VBUS=5V)

Typical Characteristics for Sink Mode

$T_A = 25^\circ\text{C}$, $V_{BUS} = 20\text{V}$, $ENB_SNK = EN_SRC = 0\text{V}$, $C_{V_{BUS}} = 10\mu\text{F}$, $C_{V_{CHG}} = 120\mu\text{F}$, $C_{SS} = 5.6\text{nF}$, $POVP = \text{GND}$, no load, unless otherwise specified.

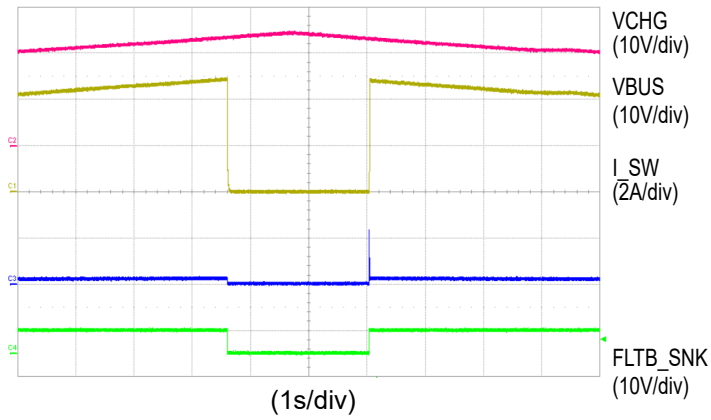

Figure 14. Sink Mode Over Voltage Protection

Typical Characteristics for Source Mode

TA = 25°C, V5V = 5V, ENB_SNK = EN_SRC = 5V, FON = 0V, C_{VBUS} = 10μF, C_{V5V} = 80μF, R_{LIM} = 4.75kΩ, Load = 1.9Ω, unless otherwise specified.

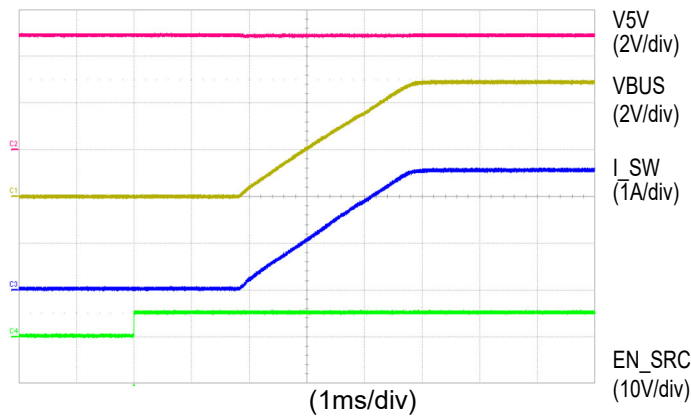

Figure 15. Source Mode Start Up by Enable

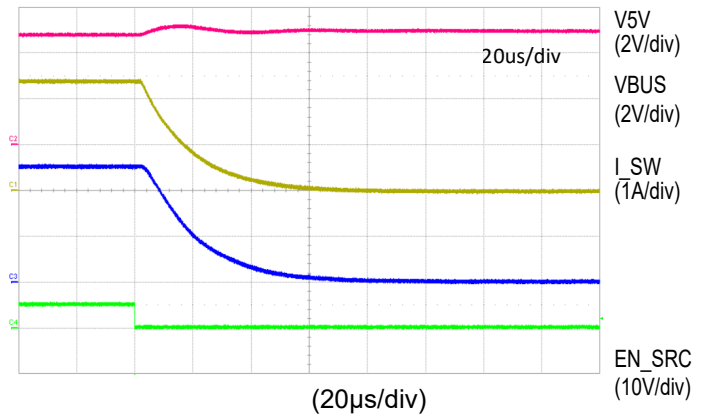

Figure 16. Source Mode Shut Down by Disable

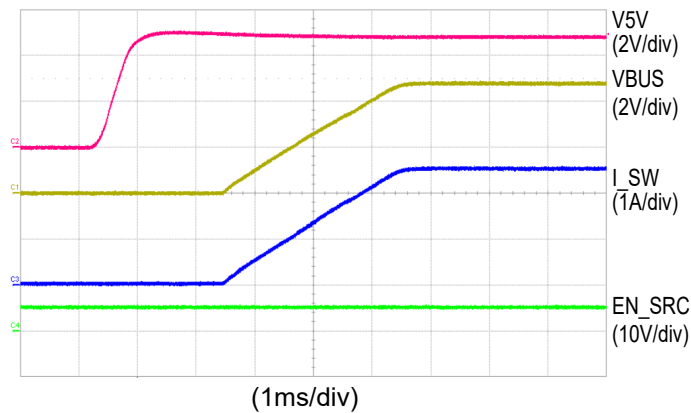

Figure 17. Source Mode Start Up by V5V Ramp

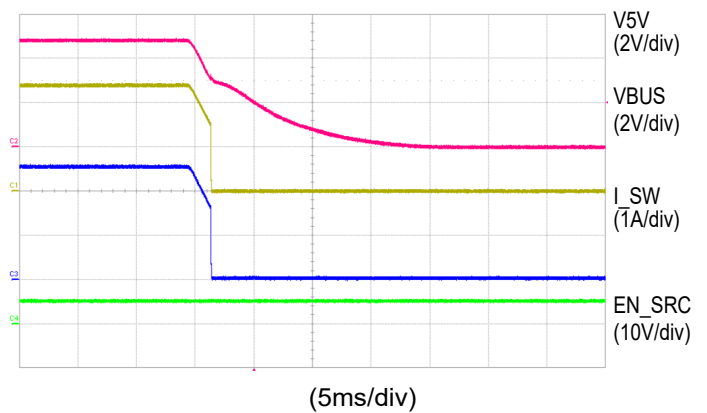

Figure 18. Source Mode Shut Down by V5V Ramp

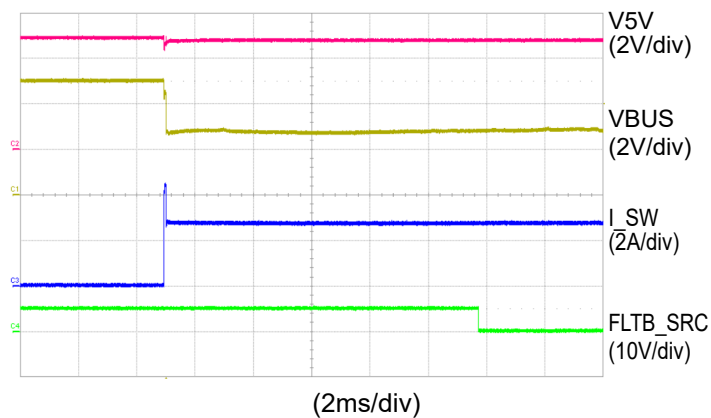

Figure 19. Source Mode Over Current Protection (Load = 1.2Ω)

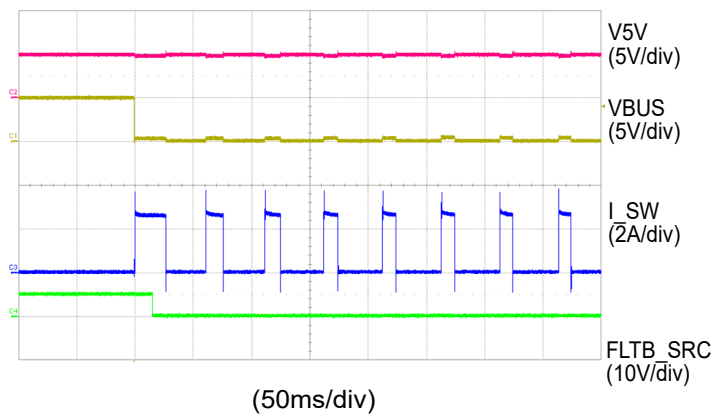

Figure 20. Source Mode Short Circuit Protection, Thermal Shut Down, and Auto Restart

Typical Performance Characteristics for Source Mode (Continued)

TA = 25°C, V5V = 5V, ENB_SNK = EN_SRC = 5V, FON = 0V, C_{VBUS} = 10μF, C_{V5V} = 80μF, R_{LIM} = 4.75kΩ, Load = 1.9Ω, unless otherwise specified.

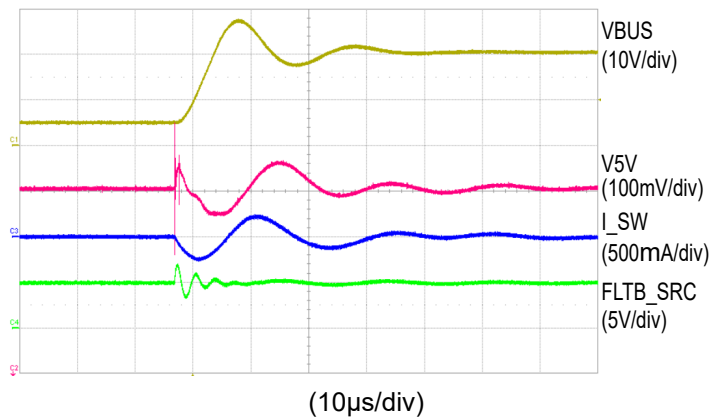

Figure 21. Source Mode True Reverse Current Blocking

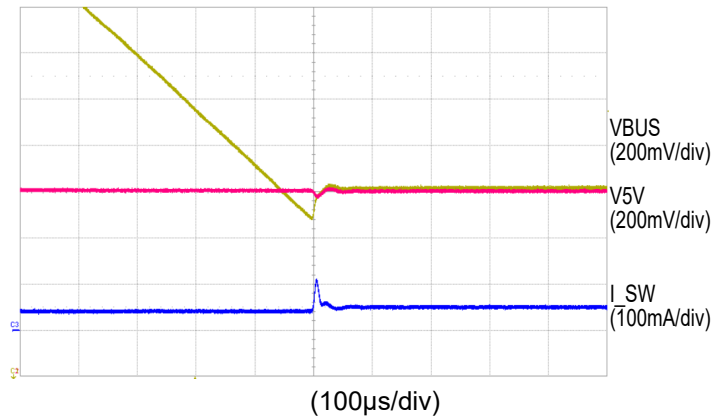

Figure 22. Source Mode Recovery from True Reverse Current Blocking Release

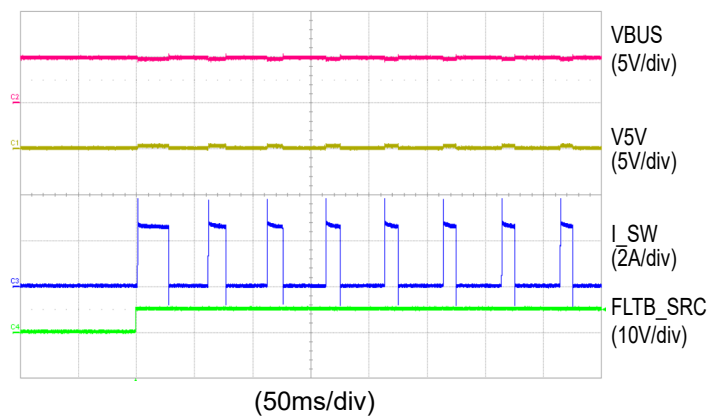

Figure 23. Source Mode Start Up to Short Condition

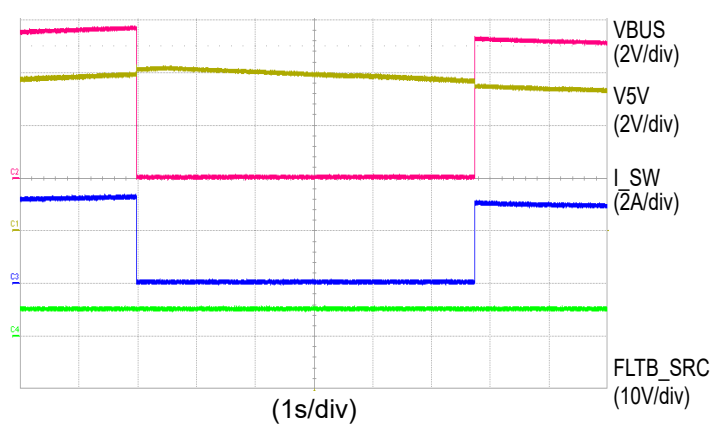

Figure 24. Source Mode Over Voltage Protection

Application Information

AOZ1380DI can operate in both sink and source mode as selected by ENB_SNK and EN_SRC. Only one mode can be active at any time. The sinking mode acts as a load for the USB Type-C connector. It passes current from the connector (VBUS) to the output supply (VCHG). The sourcing mode acts as a power supply for the connector. It passes current from (V5V) to the connector (VBUS).

Power Delivery Capability

During start-up, the voltage at VCHG linearly ramps up to the VBUS voltage over a period of time set by the soft-start time. This ramp time is referred to as the soft-start time and is typically in milliseconds. Figure 25 illustrates the soft-start condition and power dissipation.

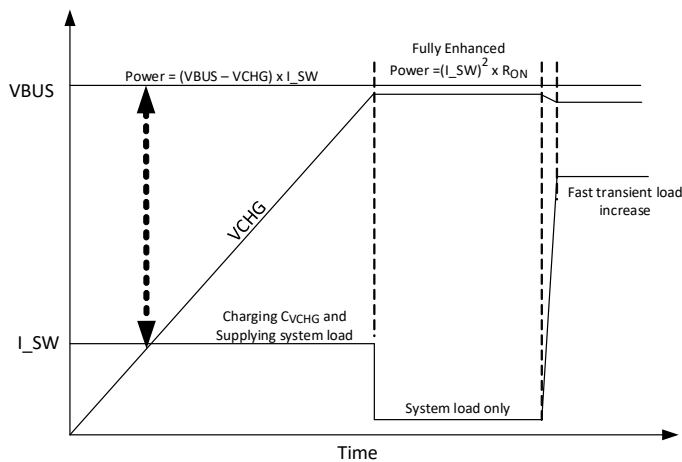

Figure 25. Soft start power dissipation

During this soft-start time, there will be a large voltage across the power switch. Also, there will be current I_{SW} through the switch to charge the output capacitance. In addition, there may be load current to the downstream system as well. This total current is calculated as:

$$I_{SW} = C_{VCHG} \left(\frac{dV_{CHG}}{dt} \right) + I_{SYS}$$

In the soft-start condition, the switch is operating in the linear mode, and power dissipation is high. The ability to handle this power is largely a function of the power MOSFET linear mode SOA and good package thermal performance (R_{thj-c}) as the soft-start ramp time is in milliseconds. $R_{thj-ambient}$, which is more a function of PCB thermal performance,

doesn't play a role. With a high-reliability MOSFET as the power switch and superior packaging technology, the AOZ1380DI is capable of dissipating this power. The power dissipated is:

$$\text{Power Dissipation} = I_{SW} \times (VBUS - V_{CHG})$$

To calculate the average power dissipation during the soft-start period: $\frac{1}{2}$ of the input voltage should be used as the output voltage will ramp towards the input voltage, as shown in Figure 25.

For example, if the output capacitance C_{VCHG} is $10\mu F$, the input voltage VBUS is 20V, the soft start time is 2ms, and there is an additional 1A of system current (I_{SYS}), then the average power being dissipated by the part is:

$$I_{SW} = 10\mu F \left(\frac{20V}{2ms} \right) + 1A = 1.1A$$

$$\text{Average Power Dissipation} = 1.1A \times \frac{20V}{2} = 11W$$

Referring to the SOA curve in Figure 26, the maximum power allowed for 2ms (DC) is 50W ($2.5A \times 20V$ or $5A \times 10V$). The AOZ1380DI power switch is robust enough to drive a large output capacitance with load in a reasonable soft start time.

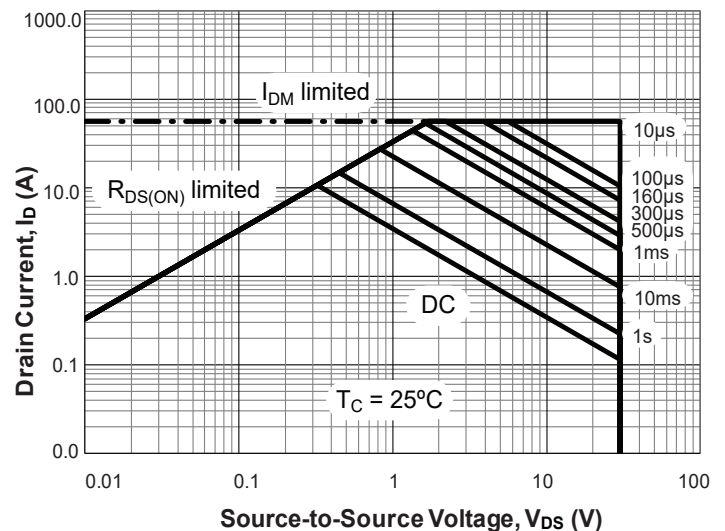

Figure 26. Safe Operating Area (SOA) curves for Sink power switch

After soft-start is completed, the power switch is fully on, and it is at its lowest resistance. The power switch acts as a resistor. Under this condition, the power dissipation is much lower than the soft-start period. However, as this

is a continuous current, a low on-resistance is required to minimize power dissipation. Attention must be paid to board layout so that losses dissipated in the sinking switch are dissipated to the PCB and hence the ambient. With a low on-resistance of 20mΩ, the AOZ1380DI provides the most efficient power delivery without much resistive power dissipation.

While Type C power delivery is limited to 20V @ 5A or a 100W, many high-end laptops require peak currents far in excess of the 5A. While the thermal design current (TDC) for a CPU may be low, peak current (IC_{Cmax} in the case of Intel and EDP in the case of AMD) of many systems is often 2 x thermal design current. These events are typical of short duration (<2ms) and low duty cycle, but they are important for system performance as a CPU/GPU capable of operating at several GHz can boost its compute power in those 2ms peak current events. The AOZ1380DI can handle such short, high current, transient pulses without any reliability degradation, thus enhancing the performance of high-end systems when plugged into the Type C adaptor. The shorter the pulse and the lower the duty cycle, the higher the pulse current that

the part can sustain. The part has enough time to dissipate the heat generated from the pulse current with longer off-time, as shown in Figure 27. For example, AOZ1380DI can maintain 20A for 10ms with a duty cycle of 2%.

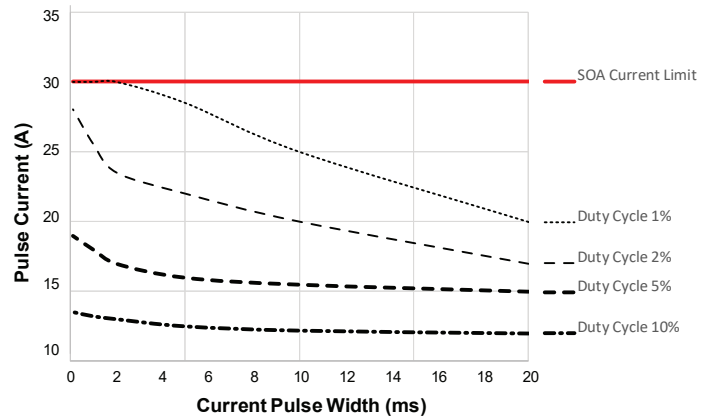

Figure 27. AOZ1380DI Sinking Switch Pulsed Current Magnitude vs. Duration for a given Duty Cycle

Sink Mode

The sinking mode power switch consists of a back-to-back connected N-channel MOSFET. It is capable of operating from 3.4V to 22V and rated up to 10A continuous current with peaks of up to 20A (for 10ms at a 2% duty cycle). It features adjustable soft-start, over-voltage, under-voltage, and over temperature protections.

When the switch is enabled, the overall resistance between VBUS and VCHG is 20mΩ, minimizing power loss and thermal dissipation. The back-to-back configuration of MOSFET completely isolates VBUS from VCHG when turned off or when VCHG > VBUS, preventing leakage current back to VBUS pin of the connector.

Enable (Active Low)

The ENB_SNK is the enable control for the sinking power path. The device is enabled when ENB_SNK input is low and device is not in the UVLO state. The ENB_SNK must be driven to a logic low or logic high to guarantee operation.

Input Under-Voltage Lockout (UVLO)

The internal circuitry of sinking path is powered from VBUS. The Under-Voltage Lockout (UVLO) circuit monitors the voltage at the VBUS pin and only allows the power switch to turn on when VBUS is higher than 3.4V.

Programmable Over-Voltage Protection (OVP)

The voltage at the VBUS pin is constantly monitored once the device is enabled. When VBUS exceeds the programmed over voltage threshold, Over-Voltage Protection (OVP) is activated and the following actions will be taken

- If the power switch is on, it will be turned off immediately to isolate VCHG from VBUS;
- OVP will prevent power switch to be turned on if it is in off state.

In either case FLTB_SNK pin is pulled low to report the fault condition.

The device over-voltage threshold can be programmed using the POVP pin. Connect POVP pin directly to ground (or use a 10kΩ or smaller resistor) to program the OVP threshold to 24V. Alternatively, the POVP pin may be floated (or use a 400KΩ resistor or greater to connect to ground) to program OVP threshold to 5.8V. An internal 8μA current source programs POVP pin based on the table below:

Table 1: OVP Setting for Sinking Mode Operation

POVP	OVP Threshold
GND	24V
Open	5.8V

True Reverse Current Blocking (TRCB)

The AOZ1380DI immediately turns off the power switch when the output voltage is greater than the input voltage by 26mV or more (VCHG ≥ VBUS + 26mV). The FLTB_SNK pin will also be immediately pulled low to indicate the fault condition. In addition, during first enable or auto restart, the power switch will remain off if output voltage exceeds input voltage by 26mV.

Thermal Shutdown Protection

When the die temperature reaches 140°C (typ), the power switch is turned off and FLTB_SNK will be pulled low. There is a 30°C (typ) hysteresis. Over-temperature fault is removed when die temperature drops below approximately 110°C.

Soft-Start Slew-Rate Control

When ENB_SNK pin is asserted low, the slew rate control circuitry applies voltage on the gate of the sink power switch in a manner such that the VCHG voltage is ramped up linearly until it reaches the input voltage level at VBUS. The output ramp up time depends on the VBUS and POVP setting and is programmed by an external soft-start capacitor (C_{SS}). The following formula provides the estimated 10% to 90% ramp up time.

$$t_{SS} = \left(\frac{V_{VBUS}}{V_{OVP}} \right) \times \left(\left(\frac{C_{SS}}{0.0023} \right) - 100 \right)$$

Where VVBUS and VOVP are in volts and C_{SS} is in nF, t_{SS} value will be in μs.

For example, if VBUS = 20V, VOVP = 24V, and C_{SS} = 2.7nF, the VCHG ramp time will be 895μs.

System Startup

The device is enabled when ENB_SNK ≤ 0.6V and VBUS is greater than the UVLO threshold. The OVP threshold is selected by sensing POVP. The device will check if a fault condition exists. When no fault exists, the power switch will turn on and VCHG will ramp up to the input voltage in a linear, monotonic fashion. The in-rush current is limited by the soft start.

Source Mode

The sourcing mode power switch consists of a back-to-back connected N-channel MOSFET. It is capable of operating from 3.4V to 5.5V. It features adjustable current limit, over-voltage, under-voltage, and over temperature protections.

When the switch is enabled, the overall resistance between V5V and VBUS is 39mΩ, minimizing power loss and thermal dissipation. The back-to-back configuration of MOSFET completely isolates VBUS from V5V when turned off or when VBUS > V5V, preventing leakage current back to VBUS pin of the connector.

Enable (Active High)

The EN_SRC is the enable control for the sourcing power path. The device is enabled when EN_SRC input is high and device is not in the UVLO state. The EN_SRC must be driven to a logic low or logic high to guarantee operation.

Input Under-Voltage LockOut (UVLO)

The internal circuitry of the sourcing path is powered from V5V. The Under-Voltage LockOut (UVLO) circuit monitors the voltage at the V5V pin and only allows the power switch to turn on when V5V is higher than 3.4V.

Over-Voltage Protection (OVP)

The voltage at the V5V is constantly monitored once the device is enabled. In case the input voltage exceeds the over-voltage lockout threshold (V_{OVLO_SRC}), the power switch is either turned off immediately or kept off, depending on its initial state. The $V_{OVLO_SRC_HYS}$ can restart when V5V drops below the hysteresis voltage $V_{OVLO_SRC_HYS}$. Over-Current Protection (OCP)

The sourcing path features adjustable current limit to prevent an over-current condition. An external resistor R_{LIM} connected between ILIM and GND pins sets the over-current protection threshold.

The current limit threshold can be estimated using the equation below:

$$I_{LIM} = \frac{14300}{R_{LIM}} \text{ (A)}$$

R_{LIM} is in ohms.

For example, for 1A current limit threshold, a 14.3k Ω R_{LIM} resistor should be selected. A 1% resistor is recommended for R_{LIM} .

Under current-limiting, FLT_B_SRC is pulled low after delay ($t_{OCP_FLT_SRC}$). Severe overload causes excessive power dissipation and the die temperature might increase and may trigger thermal shutdown.

Short Circuit Protection (SCP)

A short circuit condition will cause the chip to clamp the current to the programmed limit value. The short circuit condition will cause large power dissipation in the switches which will cause an over temperature condition.

True Reverse Current Blocking Protection (TRCB)

True Reverse Current Blocking (TRCB) prevents undesired current flow from output to input when the power switch is in either on or off state. When the device is enabled, the power switch is quickly turned off if VBUS voltage is higher than V5V voltage. The power switch is turned on again when the VBUS voltage falls below the input by 40mV.

Thermal Shutdown Protection

When the die temperature reaches 140°C (typ), the power switch is turned off and FLT_B_SRC will be pulled low. There is a 30°C (typ) hysteresis. Over-temperature fault is removed when die temperature drops below approximately 110°C.

Soft Start

The AOZ1380DI has internal soft-start circuitry for sourcing mode to limit in-rush current due to a large capacitive load. By default, the turn-on time is 2.7ms.

In case of fast turn-on (FON is logic high) or fast recovery from TRCB, soft-start is disabled to ensure the output rises quickly.

Fast Role Swap (FRS)

The FON input control allows the power switch to turn on quickly. FON should be asserted before the device is enabled. If $V5V > VBUS$, the power switch turns on quickly by minimizing the turn on delay and disabling the internal soft-start. Over-current protection is disabled during fast turn-on. If $VBUS > V5V$ (VBUS pre-biased), the device is enabled but true reverse blocking protection (TRCB) keeps the power switch off to prevent the V5V from being pulled to the higher VBUS voltage. The power switch is kept off until the TRCB event is removed.

Fast Recovery from TRCB

Once the TRCB event is removed, the power switch turns on again quickly. The recovery time is less than 80 μ s. Soft-start is not active during fast recovery.

Applicable to Both Sink and Source Mode

Fault Reporting

The AOZ1380DI has two fault pins, one for the sink switch (FLT_B_SNK) and one for the source switch (FLT_B_SRC). Both pins are open drain output. The FLT_B_SRC pin is asserted low when either an over-current, or an over-temperature condition occurs. The FLT_B_SNK pin is asserted low when an over-voltage, over-temperature, or true-reverse-current-blocking (TRCB) occurs.

VBUS Capacitor Selection

The USB specification limits the capacitance on VBUS to a maximum of 10 μ F. Use this maximum value for noise immunity due to system noise and cable plug/unplug transients

V5V Capacitor Selection

The V5V capacitor for sourcing path prevents large voltage transients from appearing at the input, and provides the instantaneous current needed each time the switch turns on to charge output capacitors and to limit input voltage

drop. It is also to prevent high-frequency noise on the power line from passing through to the output. The V5V capacitor should be located as close to the pin as possible. A 20 μ F ceramic capacitor is recommended. However, higher capacitor values further reduce the transient voltage drop at the input.

VCHG Capacitor Selection

The VCHG capacitor for sinking path has to supply enough current for a large load that it may encounter during system transient. This bulk capacitor must be large enough to supply fast transient load in order to prevent the output from dropping.

If VCHG capacitor is too large and the output voltage is lower than approximately 300mV of the input voltage at the end of soft-start-time, short-circuit protection will be triggered to turn-off the power switch.

Layout Guidelines

AOZ1380DI is a protection switch designed deliver high current. Layout is critical to remove the heat generated by this current. For the most efficient heat sinking, connect as much copper as possible to the exposed pad. The exposed pad is the common drain of the power switch which must be electrically isolated.

On the top layer expand the exposed pad island as much as possible for optimal thermal performance. The exposed pad copper plane must be electrically isolated. See example in Figure 28.

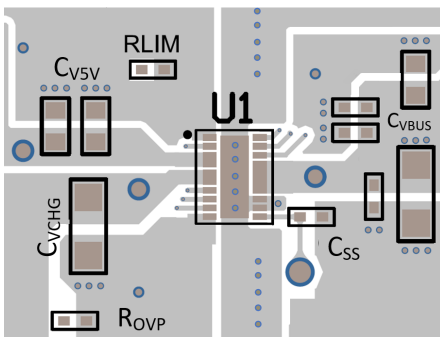

Figure 28. Top layer layout. Maximum number of VIAs from top layer exposed pad to inner layer.

There are two ways to create thermal islands on the inner layers. If the layer is flooded with a plane an isolated pad may be etched out as showed in Figure 29. If there are no flooded planes then an isolated island may be created as showed in Figure 29. The more layers that have these electrically isolated thermal heat sink islands the better the thermal performance will be. Connect all isolated thermal island (top, inner layers and bottom) together with as many VIAs as possible.

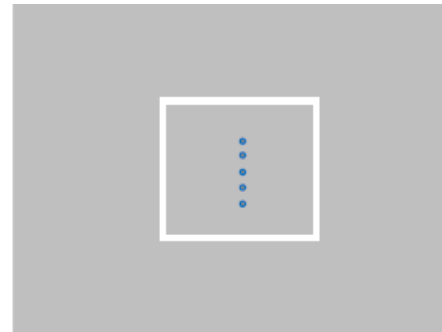

Figure 29. Inner layer layout. Create electrically isolated thermal island with flooded plane.

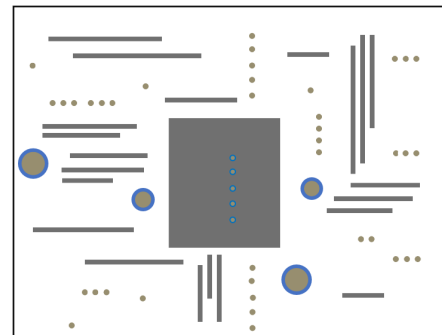

Figure 30. Inner layer layout. Create an isolated island with no flooded plane.

On the bottom layer, similar to the inner layers, create an isolated thermal island. Typically, there is more area available on the bottom area for a larger thermal pad. The top and bottom layers have better thermal performance than the inner layers because they are exposed to the atmosphere. See example in Figure 31.

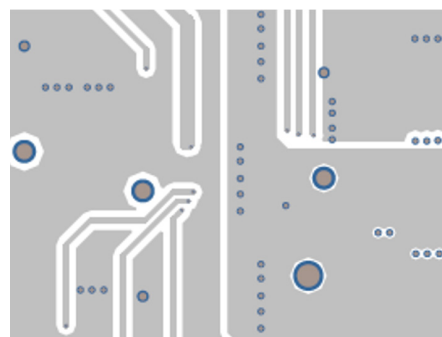
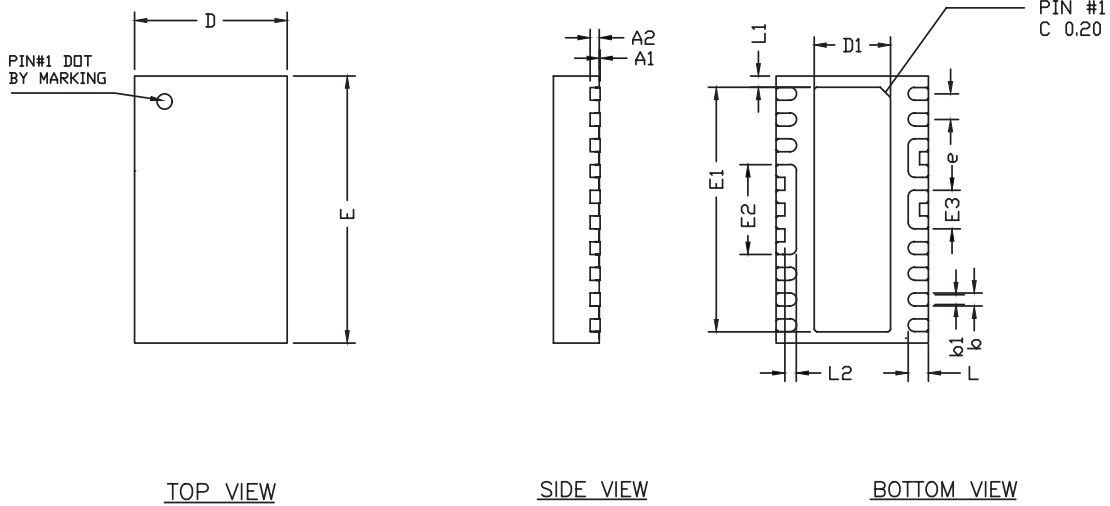

Figure 31. Bottom layer layout. Create a large electrically isolated thermal pad.

Package Dimensions, DFN3x5.2-20L



SIDE VIEW

RECOMMENDED LAND PATTERN

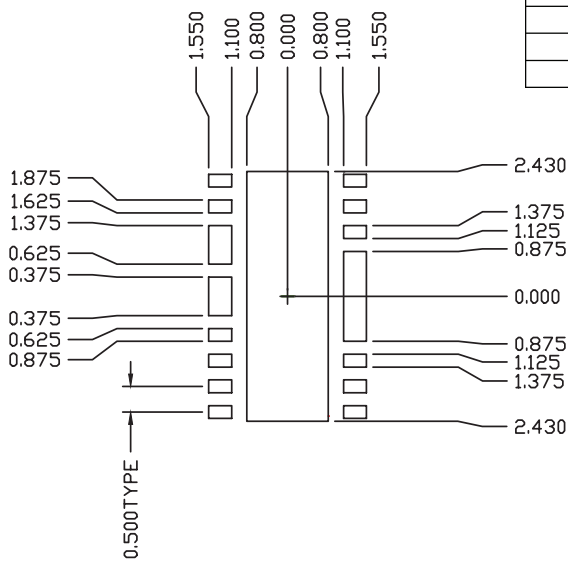

SYMBOLS	DIMENSION IN MM			DIMENSION IN INCHES		
	MIN	NOM	MAX	MIN	NOM	MAX
A	0.850	0.900	0.950	0.033	0.035	0.037
A1	0.000	-	0.050	0.000	-	0.002
A2	0.2REF			0.008REF		
D	2.900	3.000	3.100	0.114	0.118	0.122
E	5.100	5.200	5.300	0.201	0.205	0.209
D1	1.450	1.500	1.550	0.057	0.059	0.061
E1	4.710	4.760	4.810	0.185	0.187	0.189
E2	1.700	1.750	1.800	0.067	0.069	0.071
E3	0.700	0.750	0.800	0.028	0.030	0.031
L	0.350	0.400	0.450	0.014	0.016	0.018
L1	0.170	0.220	0.270	0.007	0.009	0.011
L2	0.174	0.224	0.274	0.007	0.009	0.011
b	0.200	0.250	0.300	0.008	0.010	0.012
b1	0.140	0.190	0.240	0.006	0.007	0.009
e	0.50BSC			0.02BSC		

NOTE
CONTROLLING DIMENSION IS MILLIMETER.
CONVERTED INCH DIMENSIONS ARE NOT NECESSARILY EXACT.

Tape and Reel Drawing, DFN3x5.2-20L

DFN3x5.2 20L EP1 S Carrier Tape

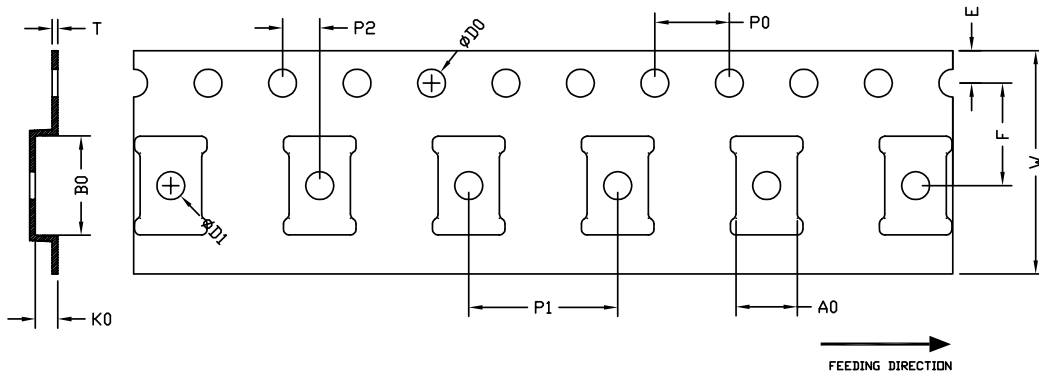

UNIT: MM

PACKAGE	A0	B0	K0	D0	D1	W	E	F	P0	P1	P2	T
DFN3x5.2	3.30 ±0.1	5.50 ±0.1	1.20 ±0.1	∅1.50 +0.1 -0.0	∅1.50 +0.2 -0.0	12.00 +0.3 -0.1	1.75 ±0.1	5.50 ±0.05	4.00 ±0.1	8.00 ±0.1	2.00 ±0.05	0.30 ±0.03

DFN3x5.2 20L EP1 S Reel

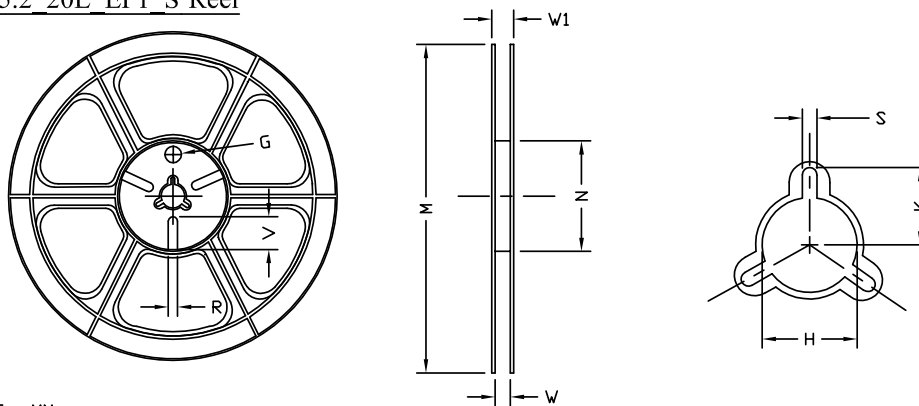

UNIT: MM

TAPE SIZE	REEL SIZE	M	N	W	W1	H	K	S	G	R	V
12 mm	∅330	∅330.00 ±0.50	∅97.00 ±0.10	13.00 ±0.30	17.40 ±1.00	∅13.00 +0.50 -0.20	10.60	2.00 ±0.50	---	---	---

DFN3x5.2 20L EP1 S Package Tape

Leader / Trailer
& Orientation

Unit Per Reel:
5000pcs

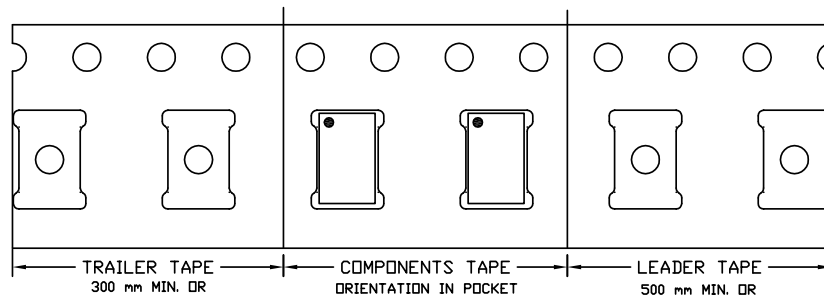

Part Marking

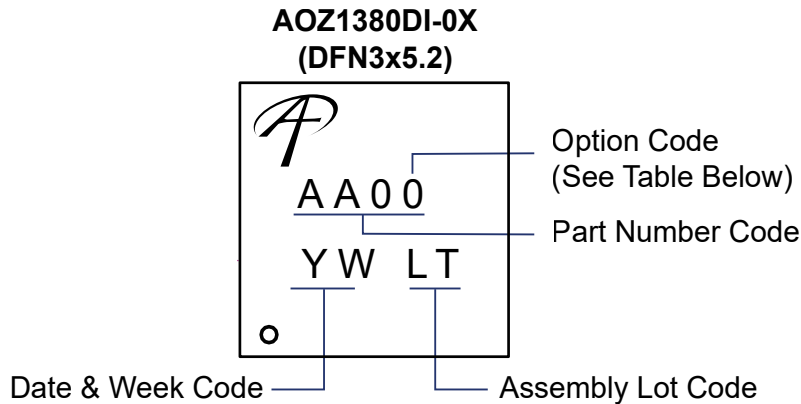

Part Number	Fault Recovery	Code
AOZ1380DI-01	Auto-Restart	AA00
AOZ1380DI-02 (Contact Sales)	Latch-Off	AA02

LEGAL DISCLAIMER

Applications or uses as critical components in life support devices or systems are not authorized. AOS does not assume any liability arising out of such applications or uses of its products. AOS reserves the right to make changes to product specifications without notice. It is the responsibility of the customer to evaluate suitability of the product for their intended application. Customer shall comply with applicable legal requirements, including all applicable export control rules, regulations and limitations.

AOS' products are provided subject to AOS' terms and conditions of sale which are set forth at:

http://www.aosmd.com/terms_and_conditions_of_sale

LIFE SUPPORT POLICY

ALPHA AND OMEGA SEMICONDUCTOR PRODUCTS ARE NOT AUTHORIZED FOR USE AS CRITICAL COMPONENTS IN LIFE SUPPORT DEVICES OR SYSTEMS.

As used herein:

1. Life support devices or systems are devices or systems which, (a) are intended for surgical implant into the body or (b) support or sustain life, and (c) whose failure to perform when properly used in accordance with instructions for use provided in the labeling, can be reasonably expected to result in a significant injury of the user.
2. A critical component in any component of a life support, device, or system whose failure to perform can be reasonably expected to cause the failure of the life support device or system, or to affect its safety or effectiveness.

Looking for pricing, stock, or lifecycle information?

Click below to explore more details on WIN SOURCE:

- ⊖ [View AOZ1380DI on WIN SOURCE](#)
- ⊖ [Alpha & Omega Semiconductor Inc. Information](#)

Optimize Your Supply Chain with WIN SOURCE Solutions

- ✓ Global Sourcing Solution
- ✓ Obsolete Management
- ✓ Cost Control Management
- ✓ Shortage Management
- ✓ Alternative Solution
- ✓ Excess Inventory Management