



**THE DATASHEET OF
AL8860QMP-13**



Description

The AL8860Q is a hysteresis mode DC-DC step-down LED driver, designed for driving single or multiple series of the connected LEDs efficiently from a voltage source higher than the LED voltage. The device can operate with an input supply voltage from 4.5V to 40V and provide an externally adjustable output current up to 1.5A for MSOP-8EP package. Depending upon supply voltage and external components, this converter can provide up to 40W output power.

The AL8860Q integrates the power switch and a high-side output current sensing circuit, which uses an external resistor to set the nominal average output current.

Dimming can be realized by applying an external control signal to the CTRL pin. The CTRL pin will accept either a DC voltage signal or a PWM signal.

The soft-start time can be adjusted by connecting an external capacitor from the CTRL pin to the ground. Applying a voltage of 0.2V or lower to the CTRL pin can turn off the switch and make the device enter into the standby mode with low power consumption.

The AL8860Q is qualified to AEC-Q100 Grade 1 and is automotive grade to support PPAPs.

Features

- Wide Input Voltage Range: 4.5V to 40V
- Output Current Up to 1.5A
- Internal 40V NDMOS Switch
- Typical 5% Output Current Accuracy
- Single Pin for On/Off and Brightness Control by DC Voltage or PWM Signal
- High Efficiency (>95%)
- LED Short-Circuit Protection
- Inherent LED Open-Circuit Protection
- Overtemperature Shutdown
- Up to 1MHz Switching Frequency
- Pb-Free MSOP-8EP Package
- **Totally Lead-Free & Fully RoHS Compliant (Notes 1 & 2)**
- **Halogen and Antimony Free. "Green" Device (Note 3)**
- **The AL8860Q is suitable for automotive applications requiring specific change control; this part is AEC-Q100 qualified, PPAP capable, and manufactured in IATF 16949 certified facilities.**

<https://www.diodes.com/quality/product-definitions/>

- Notes:
1. No purposely added lead. Fully EU Directive 2002/95/EC (RoHS), 2011/65/EU (RoHS 2) & 2015/863/EU (RoHS 3) compliant.
 2. See <https://www.diodes.com/quality/lead-free/> for more information about Diodes Incorporated's definitions of Halogen- and Antimony-free, "Green" and Lead-free.
 3. Halogen- and Antimony-free "Green" products are defined as those which contain <900ppm bromine, <900ppm chlorine (<1500ppm total Br + Cl) and <1000ppm antimony compounds.

Pin Assignments

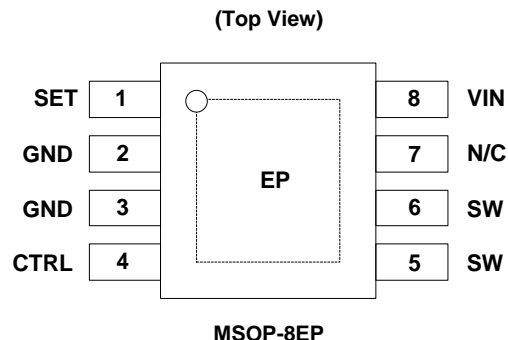

Applications

- Automotive interior LED lamps
- Automotive exterior LED lamps

Typical Application Circuit

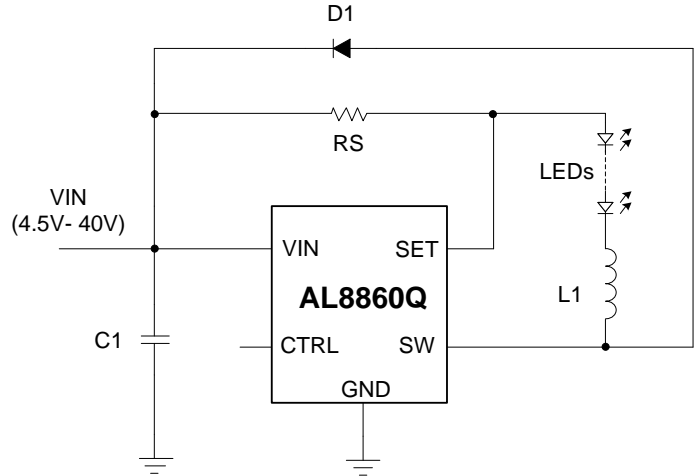

DC Power Source Input Buck Application

Pin Descriptions

Pin Number	Pin Name	Function
1	SET	Connect resistor R_s from this pin to V_{IN} to define nominal average output current: $I_{OUT_NOM} = 0.1/R_s$
2, 3	GND	Ground
4	CTRL	Multi-function On/Off and brightness control pin: <ul style="list-style-type: none"> • Leave floating for normal operation. • Drive voltage below 0.2V to turn off output current. • Drive with DC voltage ($0.3V < V_{CTRL} < 2.5V$) to adjust output current from 0 to 100% of I_{OUT_NOM}. Linear adjustment ranges from 5% to 100% of I_{OUT_NOM} • Drive with PWM signal from open-collector or open-drain transistor to adjust output current. Linear adjustment ranges from 1% to 100% of I_{OUT_NOM} for $f < 500Hz$ • Connect a capacitor from this pin to ground to increase soft-start time. (Default soft-start time = 0.1ms. Additional soft-start time is approximately 1.5ms/1nF)
5, 6	SW	Drain of NDMOS switch.
7	N/C	No Connection.
8	VIN	Input voltage (4.5V to 40V). Decouple to ground with 10 μ F or higher X7R ceramic capacitor close to device.
EP	EP	Exposed pad. Connect to GND and thermal mass for enhanced thermal impedance. Should not be used as electrical ground conduction path.

Functional Block Diagram

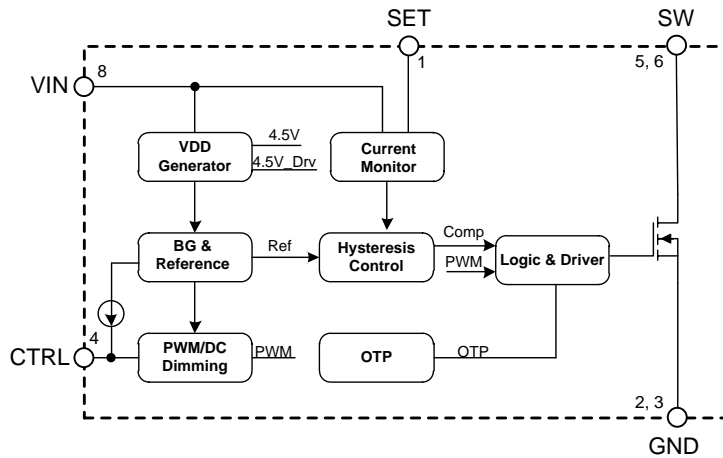

Absolute Maximum Ratings (Note 4)

Symbol	Parameter	Rating	Unit
V_{IN}	Input Voltage	-0.3 to 42	V
V_{SW}, V_{SET}	SW, SET Pin Voltage	-0.3 to 42	V
V_{CTRL}	CTRL Pin Voltage	-0.3 to 6	V
T_J	Operating Junction Temperature	-40 to +150	°C
T_{STG}	Storage Temperature Range	-65 to +150	°C
T_{LEAD}	Lead Temperature (Soldering, 10s)	+260	°C

Note: 4. Stresses greater than those listed under *Absolute Maximum Ratings* can cause permanent damage to the device. These are stress ratings only, and functional operation of the device at these or any other conditions beyond those indicated under *Recommended Operating Conditions* is not implied. Exposure to *Absolute Maximum Ratings* for extended periods can affect device reliability. Besides, if the voltage on CTRL pin is bigger than 5V, the device will enter the test mode for parameter test. Therefore, the voltage on CTRL pin should keep below 5V for normal operation.

ESD Ratings (Note 5)

Symbol	Parameter	Rating	Unit
V_{ESD}	Human Body Model (HBM), Per AEC-Q100-002	±3000	V
	Charged Device Model (CDM), Per AEC-Q100-011	±1000	

Note: 5. AEC-Q100-002 indicates that HBM stressing shall be accordance with the ANSI/ESDA/JEDEC JS-001 specification.

Recommended Operating Conditions

Symbol	Parameter	Min	Max	Unit
V_{IN}	Input Voltage	4.5	40	V
f_{SW}	Switching Frequency	—	1	MHz
I_{OUT}	Continuous Output Current	—	1.5	A
V_{CTRL}	Voltage Range for 10% to 100% DC Dimming Relative to GND Pin	0.4	2.5	V
V_{CTRL_HIGH}	Voltage High for PWM Dimming with Respect to GND Pin	2.6	5	V
V_{CTRL_LOW}	Voltage Low for PWM Dimming Relative to GND Pin	0	0.3	V
T_A	Operating Ambient Temperature	-40	+125	°C

Thermal Information (Note 6)

Symbol	Parameter	Rating	Unit
θ_{JA}	Junction-to-Ambient Thermal Resistance	56	°C/W
θ_{JC}	Junction-to-Case (Top) Thermal Resistance	15	°C/W

Note: 6. Device mounted on 2"x2" FR-4 substrate PC board, 2oz copper, with minimum recommended pad layout.

Electrical Characteristics (T_A = -40°C to +125°C, unless otherwise specified.)

Symbol	Parameter	Condition	Min	Typ	Max	Unit
INPUT VOLTAGE						
V _{IN}	Input Voltage	—	4.5	—	40	V
V _{INSU}	Internal Regulator Startup Threshold	—	—	3.8	4.5	V
V _{INSH}	Internal Regulator Hysteresis Threshold	—	200	—	630	mV
I _Q	Quiescent Current	CTRL Pin Floating, V _{IN} = 16V	—	0.55	—	mA
I _{SHDN}	Shutdown Supply Current	CTRL Pin Grounded	—	50	80	μA
HYSTERESTIC CONTROL						
V _{SENSE}	Mean Current-Sense Threshold Voltage	Measured on SET Pin with Respect to VIN Pin (T _A = +25°C)	96	100	104	mV
		Measured on SET Pin with Respect to VIN Pin (T _A = -40°C to +125°C)	95	100	105	mV
V _{SENSE_HYS}	Sense Threshold Hysteresis	—	—	±20	—	%
I _{SET}	SET Pin Input Current	V _{SET} = V _{IN} - 0.1	—	8	—	μA
ENABLE						
V _{EN}	Voltage Range on CTRL Pin	For Analog Dimming	0.3	—	2.5	V
	Analog Dimming Range	For Analog Dimming	5	—	100	%
V _{EN_ON}	DC Voltage on CTRL Pin to Enable	V _{EN} Rising	—	0.25	—	V
V _{EN_OFF}	DC Voltage on CTRL Pin to Disable	V _{EN} Falling	—	0.2	—	V
SWITCHING OPERATION						
R _{ON}	SW Switch On Resistance	@I _{SW} = 100mA	—	0.2	—	Ω
I _{SW_LEAK}	SW Switch Leakage Current	—	—	—	5	μA
t _{SS}	Soft-Start Time	V _{IN} = 16V, C _{EN} = 1nF	—	1.5	—	ms
f _{SW}	Operating Frequency	V _{IN} = 16V, V _O = 9.6V (3 LEDs), L = 47μF, ΔI = 0.25A (I _{LED} = 1A)	—	250	—	kHz
t _{ON_REC}	Recommended Minimum Switch ON Time	For 4% Accuracy	—	500	—	ns
f _{SW_MAX}	Recommended Maximum Switch Frequency	—	—	—	1.0	MHz
D _{SW_MAX}	Maximum Duty Cycle	—	—	98	—	%
t _{PD}	Internal Comparator Propagation Delay (Note 7)	—	—	100	—	ns
THERMAL SHUTDOWN						
T _{OTP}	Overtemperature Shutdown	—	—	+150	—	°C
T _{OTP_HYS}	Temperature Protection Hysteresis	—	—	+30	—	°C

Note: 7. Guaranteed by design.

Typical Performance Characteristics ($T_A = +25^\circ\text{C}$, $V_{IN} = 16\text{V}$, unless otherwise specified.)

Quiescent Current vs. Input Voltage



Quiescent Current vs. Temperature

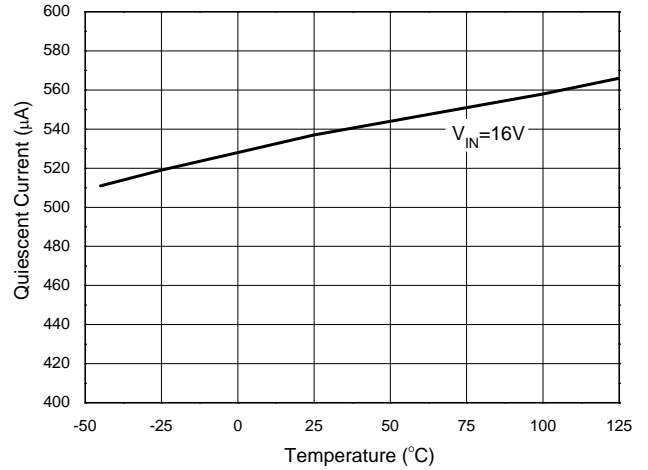

Shutdown Current vs. Input Voltage

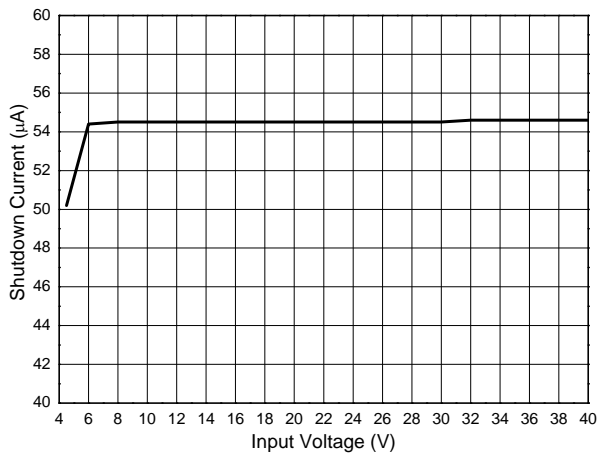

Shutdown Current vs. Temperature

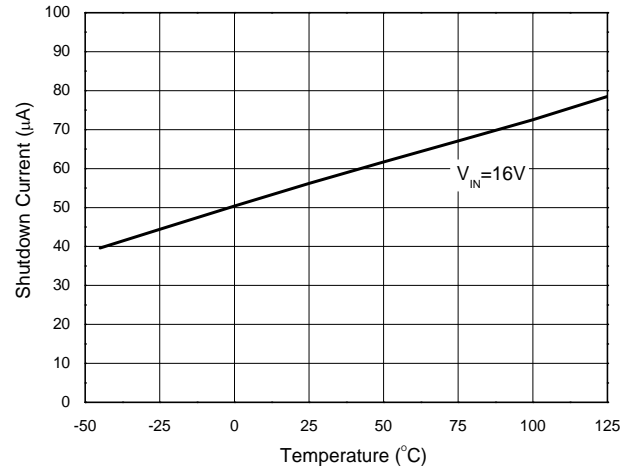

SET Threshold Voltage vs. Input Voltage

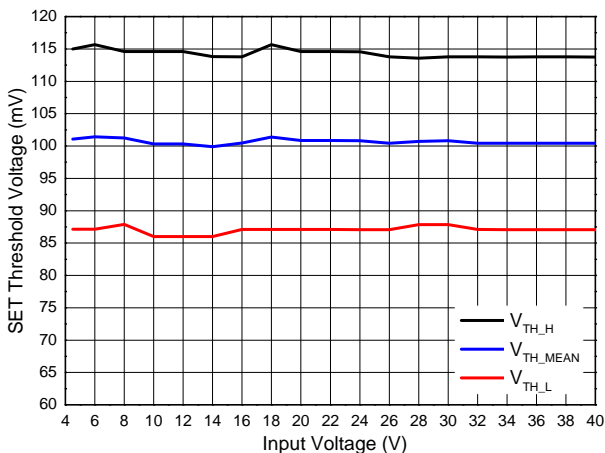

**PWM Dimming ($V_{IN}=16\text{V}$, 3 LEDs, $L = 47\mu\text{H}$, $R_S=0.3\Omega$)
Output Current vs. Duty Cycle**

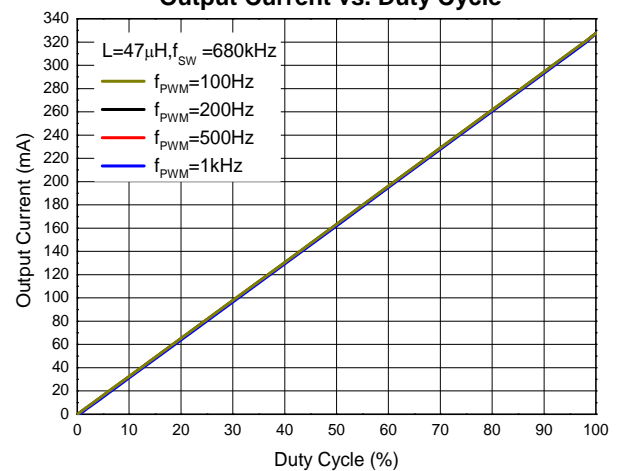

Typical Performance Characteristics ($T_A = +25^\circ\text{C}$, $V_{IN} = 16\text{V}$, unless otherwise specified.) (continued)

Analog Dimming ($V_{IN}=16\text{V}$, 3 LEDs, $L=47\mu\text{H}$, $R_S=0.3\Omega$)
LED Current vs. CTRL Pin Voltage

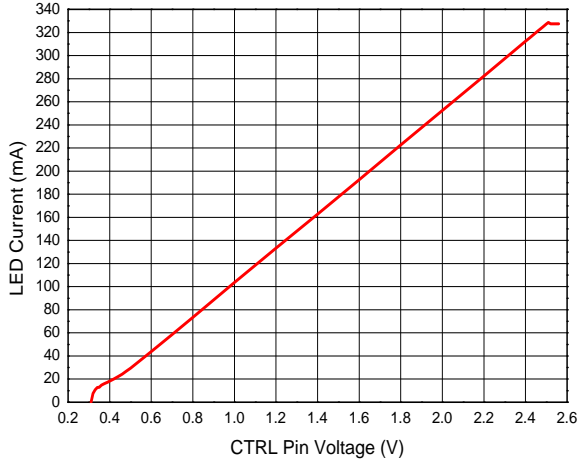

Efficiency vs. Input Voltage
($R_S=0.1\Omega$, $L=68\mu\text{H}$)

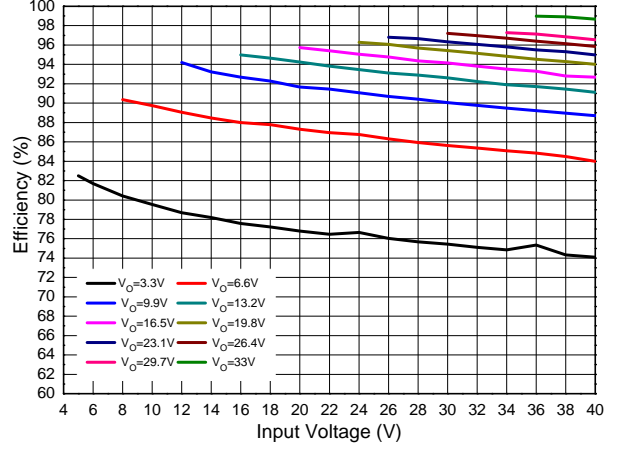

Efficiency vs. Input Voltage
($R_S=0.067\Omega$, $L=47\mu\text{H}$)

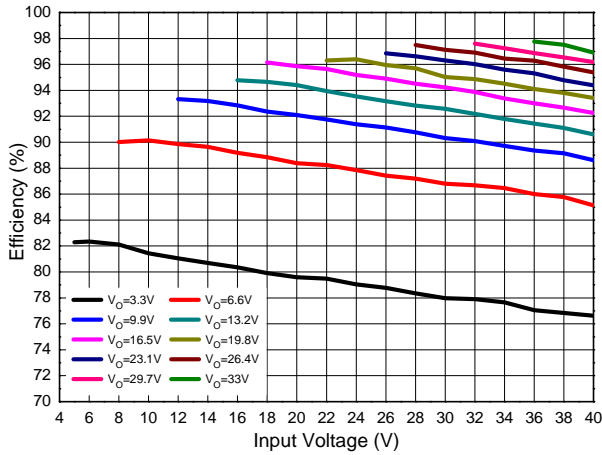

LED Current vs. Input Voltage
($R_S=0.1\Omega$, $L=68\mu\text{H}$)

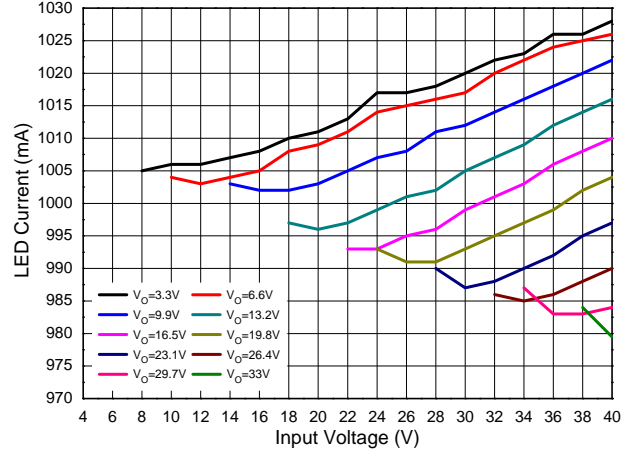

LED Current vs. Input Voltage
($R_S=0.067\Omega$, $L=47\mu\text{H}$)

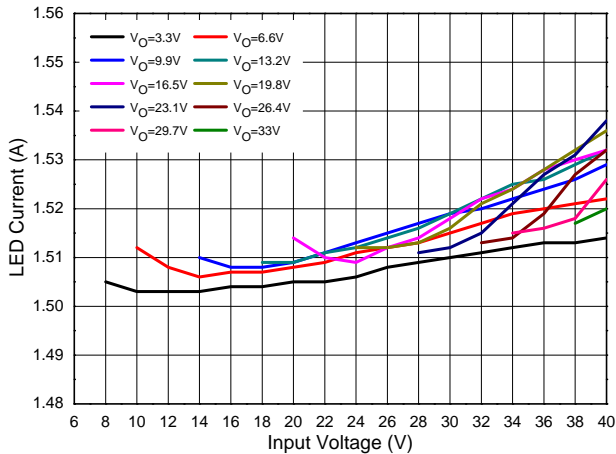

Operating Frequency vs. Input Voltage
($R_S=0.1\Omega$, $L=68\mu\text{H}$)

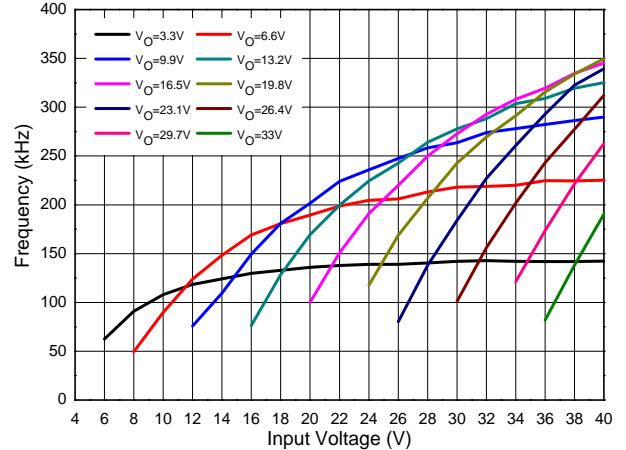

Typical Performance Characteristics ($T_A = +25^\circ\text{C}$, $V_{IN} = 16\text{V}$, unless otherwise specified.) (continued)

Operating Frequency vs. Input Voltage
($R_S=0.067\Omega$, $L=47\mu\text{H}$)

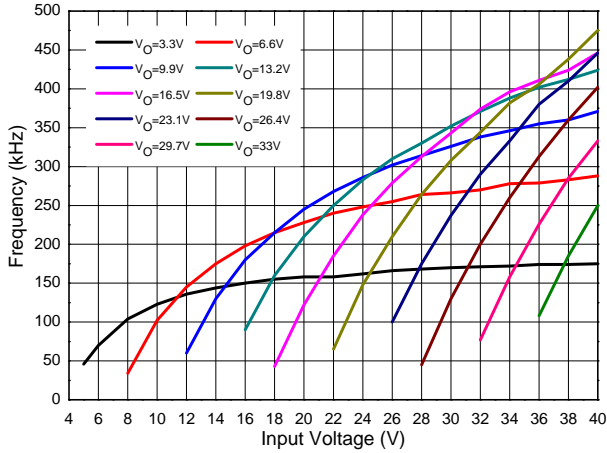

LED Current vs. Output Voltage
($R_S=0.1\Omega$, $L=68\mu\text{H}$)

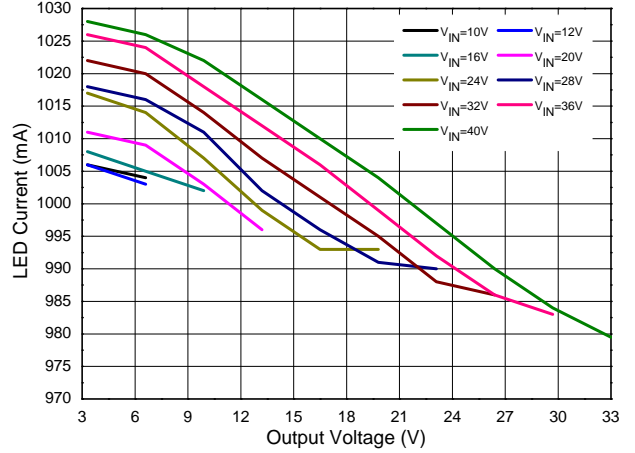

LED Current vs. Output Voltage
($R_S=0.067\Omega$, $L=47\mu\text{H}$)

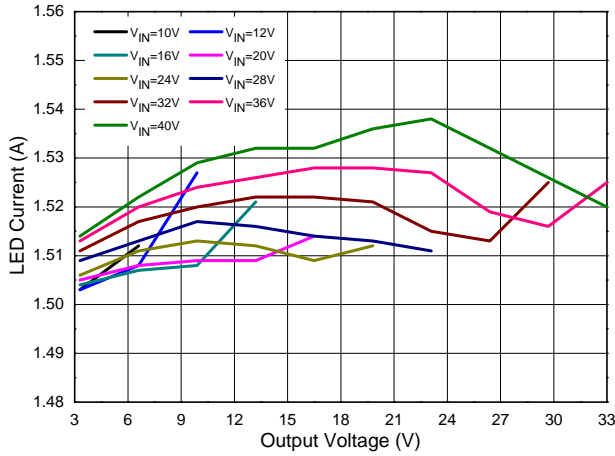

Switching Duty Cycle vs. Input Voltage
($R_S=0.067\Omega$, $L=68\mu\text{H}$)

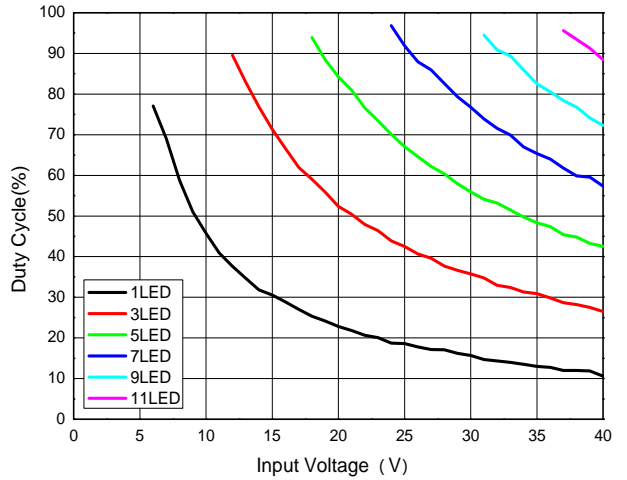

Performance Characteristics ($V_{IN} = 16V$, 3 LEDs, $R_S = 0.3\Omega$, $L = 47\mu H$, $T_A = +25^\circ C$, unless otherwise specified.)

Steady State



Startup Delay Time

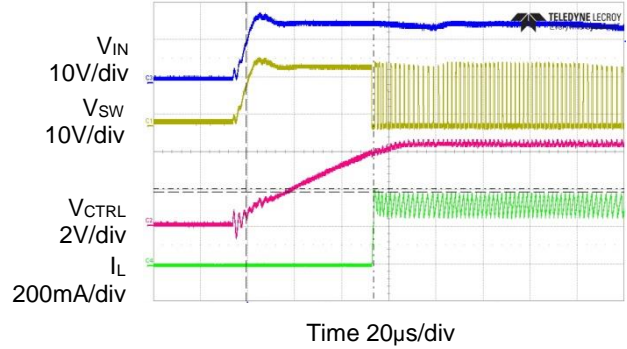

PWM Dimming (100Hz, Duty=50%)

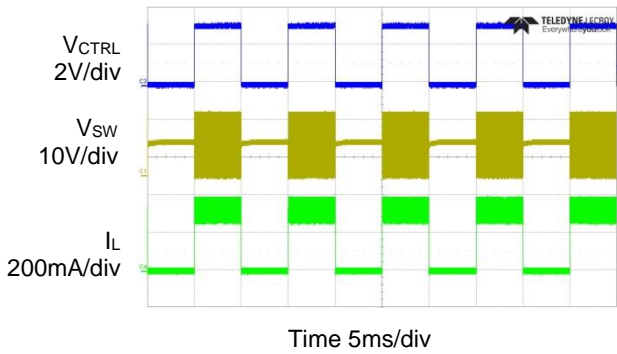

Pulse Skip Mode

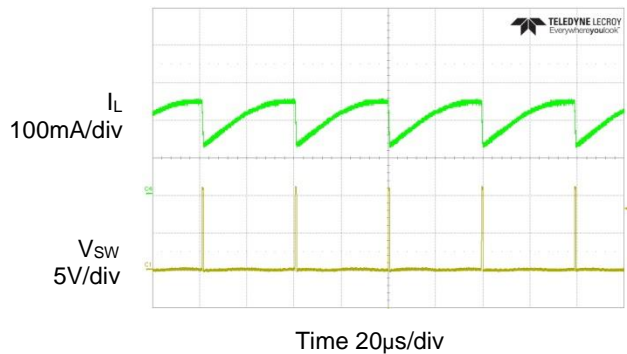

LED Open Protection

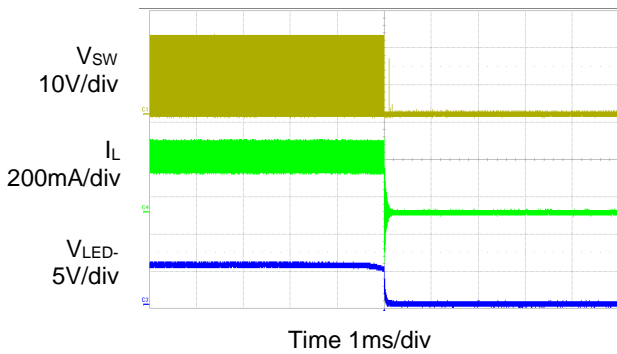

Application Information

The AL8860Q is a hysteretic mode LED driver with integrated power switch, and is available in thermal enhanced MSOP-8EP package.

AL8860Q Operation

In normal operation, when normal input voltage is applied at VIN pin, the AL8860Q internal switch will turn on. Current starts to flow through the sense resistor Rs, the inductor L1, and the LEDs. The current ramps up linearly, and the slew rate is determined by the input voltage VIN, VOUT and the inductor L1.

This rising current produces a voltage ramp across Rs. The internal circuit of the AL8860Q senses the voltage across Rs and applies a proportional voltage to the input of the internal comparator. When this voltage reaches an internal upper threshold, the internal switch is turned off. The inductor current continues to flow through Rs, L1, LEDs and diode D1, and back to the supply rail, but it decays with the rate determined by the forward voltage drop of LEDs and the diode D1.

This decaying current produces a falling voltage on Rs, which is sensed by the AL8860Q. A voltage proportional to the sense voltage across Rs will be applied at the input of internal comparator. When this voltage falls to the internal lower-set threshold, the internal switch is turned on again.

This switch-on-and-off cycle continues to provide the average LED current set by the sense resistor Rs.

LED Current Configuration

The nominal average output current in the LED(s) is determined by the value of the external current-sense resistor (Rs) connected between VIN pin and SET pin, and is given by:

$$I_{OUT(NOM)} = \frac{0.1}{R_S}$$

The table below provides values of nominal average output current for setting resistor (Rs) in the *Typical Application Circuit* shown on page 2.

Rs (Ω)	Nominal Average Output Current (mA)
0.066	1500
0.1	1000
0.13	760
0.15	667
0.3	333

The above values assume that the CTRL pin is floating and at a nominal reference voltage for internal comparator. It is possible to use different values of Rs if the CTRL pin is driven by an external dimming signal.

Analog Dimming

Applying a DC voltage from 0.3V to 2.5V on CTRL pin can adjust output current from 0 to 100% of IOUT_NOM linearly, as shown in Figure 1. If the CTRL pin is brought higher than 2.5V, the LED current will be clamped to 100% of IOUT_NOM. And the output switch will turn off if the CTRL voltage falls below the threshold of 0.3V.

PWM Dimming

The LED current can be adjusted digitally by applying a low-frequency pulse-width-modulated (PWM) logic signal to the CTRL pin to turn the device on and off. This will produce an average output current proportional to the duty cycle of the control signal. To achieve a high resolution, the PWM frequency is recommended to be lower than 500Hz; however, high dimming frequencies can be used at the expense of dimming dynamic range and accuracy. Typically, for a PWM frequency of 500Hz, the accuracy is better than 1% for PWM ranging from 1% to 100%.

The accuracy of the low duty-cycle dimming is affected by both the PWM frequency and also the switching frequency of the AL8860Q. For best accuracy/resolution, the switching frequency should be increased while the PWM frequency should be reduced.

The CTRL pin is designed to be driven by 3.3V logic level directly from a logic output with either an open-drain output or a push-pull output stage.

Application Information (continued)

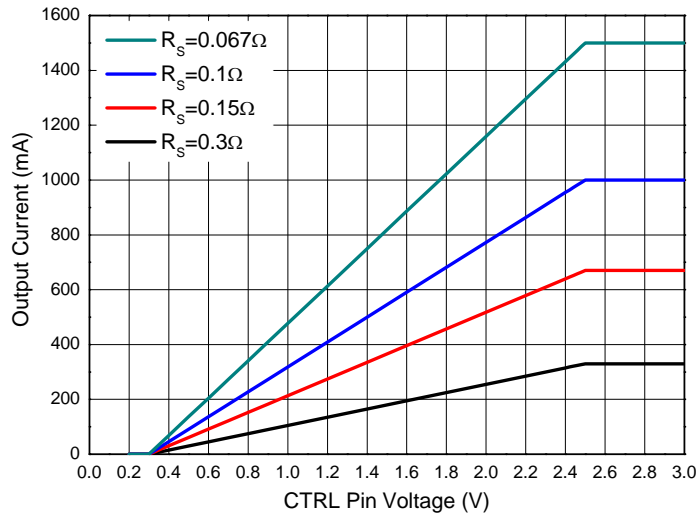

Figure 1. Analog Dimming Curve

Soft-Start

The default soft-start time for the AL8860Q is 0.1ms, and this can provide very fast turn-on of the output, improving the PWM dimming accuracy.

Nevertheless, adding an external capacitor from the CTRL pin to ground will provide a longer soft-start delay. This is achieved by increasing the time of the CTRL pin voltage rising to the turn-on threshold and slowing down the rising rate of the control voltage at the input of hysteresis comparator. The additional soft-start time is related to the capacitance between the CTRL pin and the GND pins, and the typical value will be 1.5ms/nF.

Capacitor Selection

A low ESR capacitor should be used for input decoupling, as the ESR of this capacitor appears in series with the supply source impedance and will reduce the overall efficiency. This capacitor can supply the relative high peak current to the coil and smooth the ripple on the input current.

The needed minimum capacitance is determined by input power, cable's length and peak current. 4.7μF to 10μF is a commonly used value for most cases. A higher value will improve the performance at lower input voltages, especially when the source impedance is high. The input capacitor should be placed as close as possible to the IC.

For maximum stability overtemperature and voltage, capacitors with X7R, X5R, or better dielectric are recommended. Capacitors with Y5V dielectric are not suitable for decoupling in this application and should NOT be used.

Diode Selection

For maximum efficiency and performance, the freewheeling diode (D1) should be a fast low capacitance Schottky diode with low reverse leakage current. It also provides better efficiency than the silicon diodes, due to the lower forward voltage and reduced recovery time.

It is important to select parts with a peak current rating above the peak coil current and a continuous current rating higher than the maximum output load current. It is very important to control the reverse leakage current of the diode when operating above +85°C. Excess leakage current will increase power dissipation.

The higher forward voltage and overshoot due to the reverse-recovery time in silicon diodes will increase the peak output voltage on the SW pin. If a silicon diode is used, more care should be taken to ensure the total voltage appearing on the SW pins including supply ripple won't exceed the specified maximum value.

Application Information (continued)

Inductor Selection

Recommended inductor value for the AL8860Q is in the range of 33µH to 100µH. Higher inductance is recommended at higher supply voltages in order to minimize output current tolerance due to the switching delays, which will result in the increased ripple and lower efficiency. Higher inductance also results in a better line regulation. The inductor should be mounted as close to the device as possible with low resistance connections to SW pins.

The chosen coil should have saturation current higher than the peak output current and a continuous current rating above the required mean output current.

The inductor value should be chosen to maintain the operating duty cycle and the switch-on/off times within the specified limits over the supply voltage and the load current range. The following equations can be used as a guide.

SW Pin Switch 'On' Time

$$t_{ON} = \frac{L\Delta I}{V_{IN} - V_{LED} - I_{LED}(R_S + R_L + R_{sw})}$$

SW Pin Switch 'Off' Time

$$t_{OFF} = \frac{L\Delta I}{V_{LED} + V_D + I_{LED}(R_S + R_L)}$$

Where: L is the coil inductance; R_L is the coil resistance; R_s is the current-sense resistance; I_{LED} is the required LED current; ΔI is the coil peak-peak ripple current (Internally set to 0.4 x I_{LED}); V_{IN} is the supply voltage; V_{LED} is the total LED forward voltage; R_{sw} is the switch resistance (0.3Ω nominal); V_D is the diode forward voltage at the required load current.

Thermal Protection

The AL8860Q includes overtemperature protection (OTP) circuitry that will turn off the device if its junction temperature reaches T_{OTP}. This is to protect the device from excessive heat damage. The OTP circuitry includes thermal hysteresis that will cause the device to restart the normal operation once its junction temperature has cooled down by approximately T_{OTP_HYS}.

LED Open-Circuit Protection

The AL8860Q has the default open LED protection. If the LEDs become open circuit, the AL8860Q will stop switching; the voltage at the SET pin will rise to the voltage at the VIN pin, and the voltage at the SW pin will then fall to the voltage at the GND. No excessive voltages will be seen by the AL8860Q.

LED Short-Circuit Protection

If the LED chain becomes shorted together (the anode of the top LED becomes shorted to the cathode of the bottom LED). The AL8860Q will continue to switch and the current through the AL8860Q's internal switch will still be at the regulated current, so no excessive heat will be generated within the AL8860Q. However, the duty cycle will change dramatically and the switching frequency will most likely decrease. See Figure 2 for an example of this status at 24V input voltage driving 3 LEDs.

The on-time of the internal power MOSFET switch is significantly reduced because almost all of the input voltage is now developed across the inductor. The off-time is significantly increased because the reverse voltage across the inductor is now just the Schottky diode voltage (See Figure 2) causing a much slower decay in inductor current.

Application Information (continued)

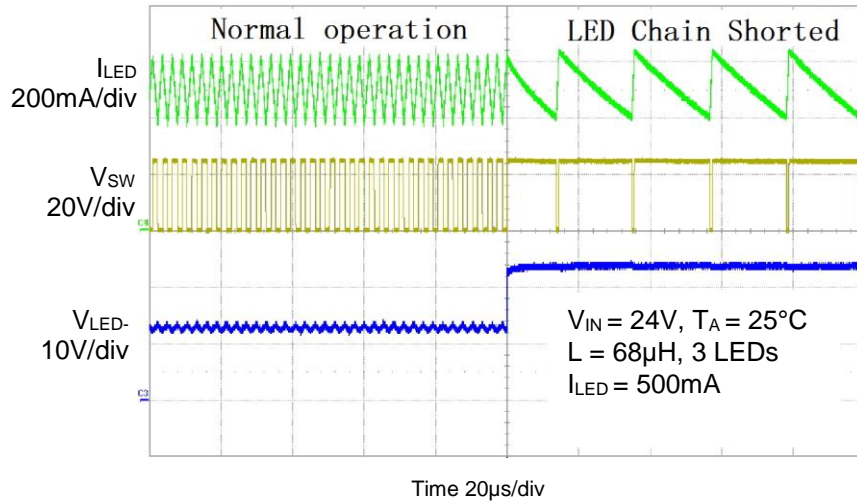

Figure 2. Switching Characteristics (Normal Operation to LED Chain Shorted Out)

EMI and Layout Considerations

The AL8860Q is a switching regulator with fast edges and measures small differential voltages; as a result, care has to be taken with decoupling and layout of the PCB. To help with these effects the AL8860Q has been developed to minimize radiated emissions by controlling the switching speeds of the internal power MOSFET. The rise and fall times are controlled to get the right compromise between power dissipation due to switching losses and radiated EMI. The turn-on edge (falling edge) dominates the radiated EMI which is due to an interaction among the Schottky diode (D1), Switching MOSFET and PCB tracks. After the Schottky diode reverse-recovery time of around 5ns has occurred, the falling edge of the SW pin sees a resonant loop between the Schottky diode capacitance and the track inductance, L_{TRACK} . See Figure 3.

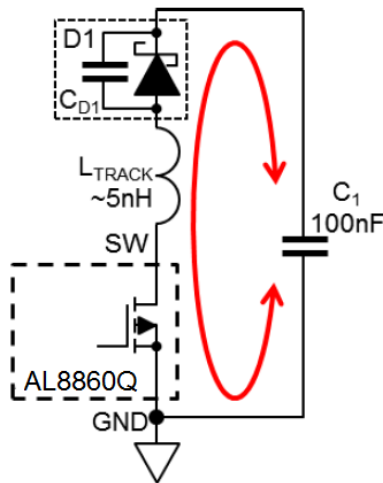

Figure 3. PCB Loop Resonance

The tracks from the SW pin to the anode of the Schottky diode, D1, and then from D1's cathode to the decoupling capacitors C1 should be as short as possible. There is an inductance internally in the AL8860Q which can be assumed to be around 1nH. For PCB tracks a figure of 0.5nH per mm can be used to estimate the primary resonant frequency. If the track is capable of handling 1A, increasing the thickness will have a minor effect on the inductance and length will dominate the size of the inductance. The resonant frequency of any oscillation is determined by the combined inductance in the track and the effective capacitance of the Schottky diode.

Application Information (continued)

Recommendations for minimizing radiated EMI and other transients and thermal considerations are:

1. The decoupling capacitor (C1) has to be placed as close as possible to the VIN pin and D1 cathode.
2. The freewheeling diode's (D1) anode, the SW pin and the inductor have to be placed as close as possible to each other to avoid ringing.
3. The Ground return path from C1 must be a low impedance path with the ground plane as large as possible.
4. The LED current-sense resistor (Rs) has to be placed as close as possible to the VIN and SET pins.
5. The majority of the conducted heat from the AL8860Q is through the GND pin 2. A maximum earth plane with thermal vias into a second earth plane will minimise self-heating.
6. To reduce emissions via long leads on the supply input and LEDs, low RF impedance capacitors should be used at the point where the wires are joined to the PCB.

Ordering Information (Note 8)

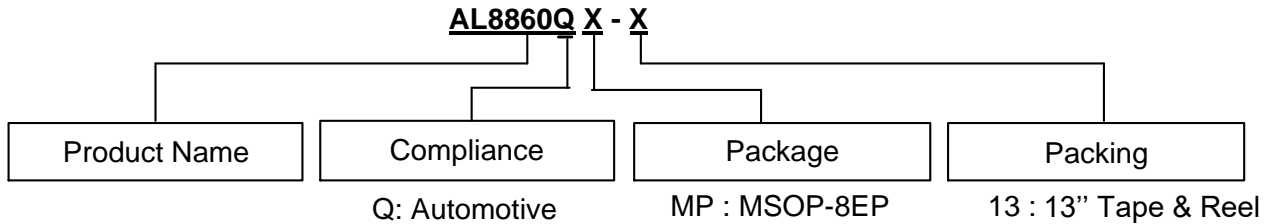

Part Number	Package Code	Package	Packing	
			Qty.	Carrier
AL8860QMP-13	MP	MSOP-8EP	2500	13'' Tape & Reel

Note: 8. For packaging details, go to our website at <https://www.diodes.com/design/support/packaging/diodes-packaging/>.

Marking Information

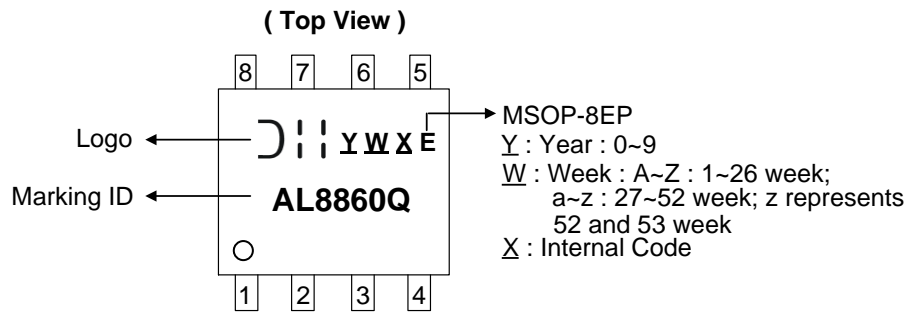

Part Number	Package	Marking ID
AL8860QMP-13	MSOP-8EP	AL8860Q

Package Outline Dimensions

Please see <http://www.diodes.com/package-outlines.html> for the latest version.

MSOP-8EP

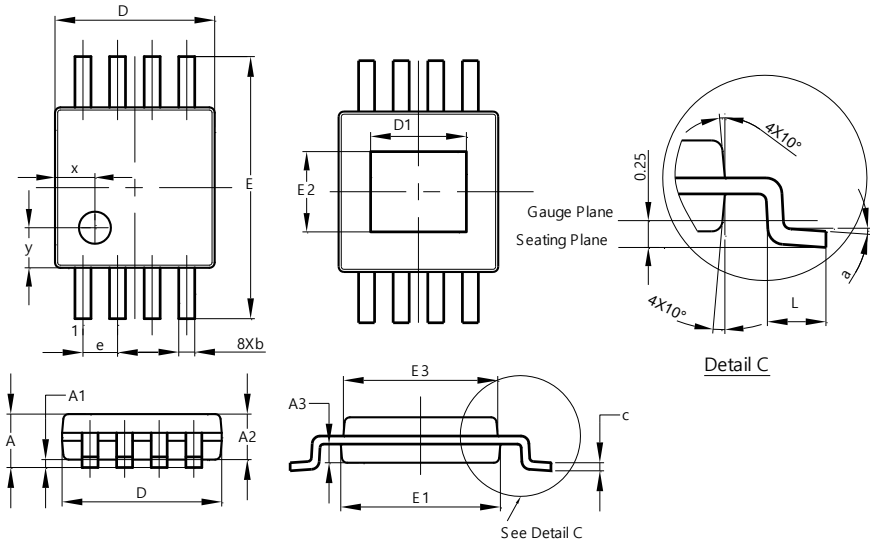

MSOP-8EP			
Dim	Min	Max	Typ
A	-	1.10	-
A1	0.05	0.15	0.10
A2	0.75	0.95	0.86
A3	0.29	0.49	0.39
b	0.22	0.38	0.30
c	0.08	0.23	0.15
D	2.90	3.10	3.00
D1	1.60	2.00	1.80
E	4.70	5.10	4.90
E1	2.90	3.10	3.00
E2	1.30	1.70	1.50
E3	2.85	3.05	2.95
e	-	-	0.65
L	0.40	0.80	0.60
a	0°	8°	4°
x	-	-	0.750
y	-	-	0.750
All Dimensions in mm			

Suggested Pad Layout

Please see <http://www.diodes.com/package-outlines.html> for the latest version.

MSOP-8EP

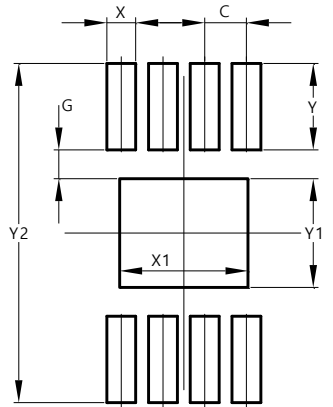

Dimensions	Value (in mm)
C	0.650
G	0.450
X	0.450
X1	2.000
Y	1.350
Y1	1.700
Y2	5.300

Mechanical Data

- Moisture Sensitivity: Level 1 per JESD22-A113
- Terminals: Finish – Matte Tin Plated Leads, Solderable per M2003 JESD22-B102 ③
- Weight: 0.026 grams (Approximate)

IMPORTANT NOTICE



1. DIODES INCORPORATED (Diodes) AND ITS SUBSIDIARIES MAKE NO WARRANTY OF ANY KIND, EXPRESS OR IMPLIED, WITH REGARDS TO ANY INFORMATION CONTAINED IN THIS DOCUMENT, INCLUDING, BUT NOT LIMITED TO, THE IMPLIED WARRANTIES OF MERCHANTABILITY, FITNESS FOR A PARTICULAR PURPOSE OR NON-INFRINGEMENT OF THIRD PARTY INTELLECTUAL PROPERTY RIGHTS (AND THEIR EQUIVALENTS UNDER THE LAWS OF ANY JURISDICTION).
2. The Information contained herein is for informational purpose only and is provided only to illustrate the operation of Diodes' products described herein and application examples. Diodes does not assume any liability arising out of the application or use of this document or any product described herein. This document is intended for skilled and technically trained engineering customers and users who design with Diodes' products. Diodes' products may be used to facilitate safety-related applications; however, in all instances customers and users are responsible for (a) selecting the appropriate Diodes products for their applications, (b) evaluating the suitability of Diodes' products for their intended applications, (c) ensuring their applications, which incorporate Diodes' products, comply the applicable legal and regulatory requirements as well as safety and functional-safety related standards, and (d) ensuring they design with appropriate safeguards (including testing, validation, quality control techniques, redundancy, malfunction prevention, and appropriate treatment for aging degradation) to minimize the risks associated with their applications.
3. Diodes assumes no liability for any application-related information, support, assistance or feedback that may be provided by Diodes from time to time. Any customer or user of this document or products described herein will assume all risks and liabilities associated with such use, and will hold Diodes and all companies whose products are represented herein or on Diodes' websites, harmless against all damages and liabilities.
4. Products described herein may be covered by one or more United States, international or foreign patents and pending patent applications. Product names and markings noted herein may also be covered by one or more United States, international or foreign trademarks and trademark applications. Diodes does not convey any license under any of its intellectual property rights or the rights of any third parties (including third parties whose products and services may be described in this document or on Diodes' website) under this document.
5. Diodes' products are provided subject to Diodes' Standard Terms and Conditions of Sale (<https://www.diodes.com/about/company/terms-and-conditions/terms-and-conditions-of-sales/>) or other applicable terms. This document does not alter or expand the applicable warranties provided by Diodes. Diodes does not warrant or accept any liability whatsoever in respect of any products purchased through unauthorized sales channel.
6. Diodes' products and technology may not be used for or incorporated into any products or systems whose manufacture, use or sale is prohibited under any applicable laws and regulations. Should customers or users use Diodes' products in contravention of any applicable laws or regulations, or for any unintended or unauthorized application, customers and users will (a) be solely responsible for any damages, losses or penalties arising in connection therewith or as a result thereof, and (b) indemnify and hold Diodes and its representatives and agents harmless against any and all claims, damages, expenses, and attorney fees arising out of, directly or indirectly, any claim relating to any noncompliance with the applicable laws and regulations, as well as any unintended or unauthorized application.
7. While efforts have been made to ensure the information contained in this document is accurate, complete and current, it may contain technical inaccuracies, omissions and typographical errors. Diodes does not warrant that information contained in this document is error-free and Diodes is under no obligation to update or otherwise correct this information. Notwithstanding the foregoing, Diodes reserves the right to make modifications, enhancements, improvements, corrections or other changes without further notice to this document and any product described herein. This document is written in English but may be translated into multiple languages for reference. Only the English version of this document is the final and determinative format released by Diodes.
8. Any unauthorized copying, modification, distribution, transmission, display or other use of this document (or any portion hereof) is prohibited. Diodes assumes no responsibility for any losses incurred by the customers or users or any third parties arising from any such unauthorized use.
9. This Notice may be periodically updated with the most recent version available at <https://www.diodes.com/about/company/terms-and-conditions/important-notice>

The Diodes logo is a registered trademark of Diodes Incorporated in the United States and other countries.
All other trademarks are the property of their respective owners.
© 2023 Diodes Incorporated. All Rights Reserved.

www.diodes.com

Looking for pricing, stock, or lifecycle information?

Click below to explore more details on WIN SOURCE:

-  [View AL8860QMP-13 on WIN SOURCE](#)
-  [Diodes Incorporated Information](#)

Optimize Your Supply Chain with WIN SOURCE Solutions

-  Global Sourcing Solution
-  Obsolete Management
-  Cost Control Management
-  Shortage Management
-  Alternative Solution
-  Excess Inventory Management