



**THE DATASHEET OF
AL3353S-13**



Description

The AL3353 is a highly-integrated and cost-effective Light Emitting Diode (LED) controller optimized for LCD monitor and LCD TV backlighting application. It provides a high-performance LED backlight solution with low-BOM cost.

The AL3353 contains a PWM boost driver, which uses current mode control and fixed frequency operation to regulate the LED current. The LED current is sensed through an external current sense resistor. The voltage across the sensing resistor is compared with reference level of 400mV; the error is amplified to control the pulse width of the power switch thus to regulate the current flowing the LED.

The AL3353 offers PWM-to-analog dimming mode for a wide range of dimming control.

The AL3353 has comprehensive protection features such as power MOSFET overcurrent protection (OCP), output overvoltage protection (OVP), diode and inductor short protection, LED cathode short-to-GND protection, IC power supply undervoltage lockout (UVLO), LED open protection, V_{OUT} short protection, and overtemperature protection (OTP).

The AL3353 is available in the SO-8 (Type TH2) package.

Features

- Wide Input Voltage Range: 9V to 40V
- High Precision Feedback Reference Voltage: 400mV/±1.5%
- Current Mode PWM Controller with Good Dynamic Response
- PWM to Analog Dimming Mode
- Built-In Comprehensive Protections
 - Undervoltage Lockout (UVLO)
 - Output Overvoltage Protection (OVP)
 - Power MOSFET Overcurrent Protection (OCP)
 - Diode and Inductor Short Protection
 - LED Cathode Short to GND Protection
 - LED Open Protection
 - V_{OUT} Short Protection
 - Overtemperature Protection (OTP)
- Available in Pb-Free SO-8 (Type TH2) Package
- **Totally Lead-Free & Fully RoHS Compliant (Notes 1 & 2)**
- **Halogen and Antimony Free. "Green" Device (Note 3)**

Notes:

1. No purposely added lead. Fully EU Directive 2002/95/EC (RoHS), 2011/65/EU (RoHS 2) & 2015/863/EU (RoHS 3) compliant.
2. See <https://www.diodes.com/quality/lead-free/> for more information about Diodes Incorporated's definitions of Halogen- and Antimony-free, "Green" and Lead-free.
3. Halogen- and Antimony-free "Green" products are defined as those which contain <900ppm bromine, <900ppm chlorine (<1500ppm total Br + Cl) and <1000ppm antimony compounds.

Pin Assignments

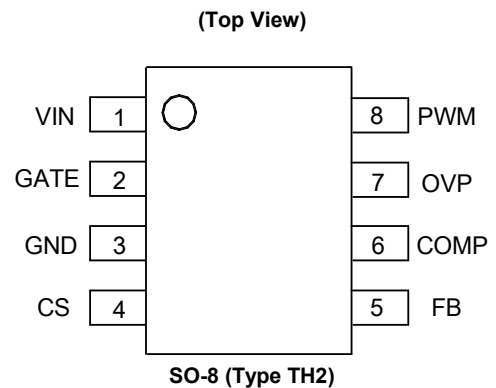

Applications

- LCD TV
- LCD Monitor
- Flat Panel Display

Typical Applications Circuit

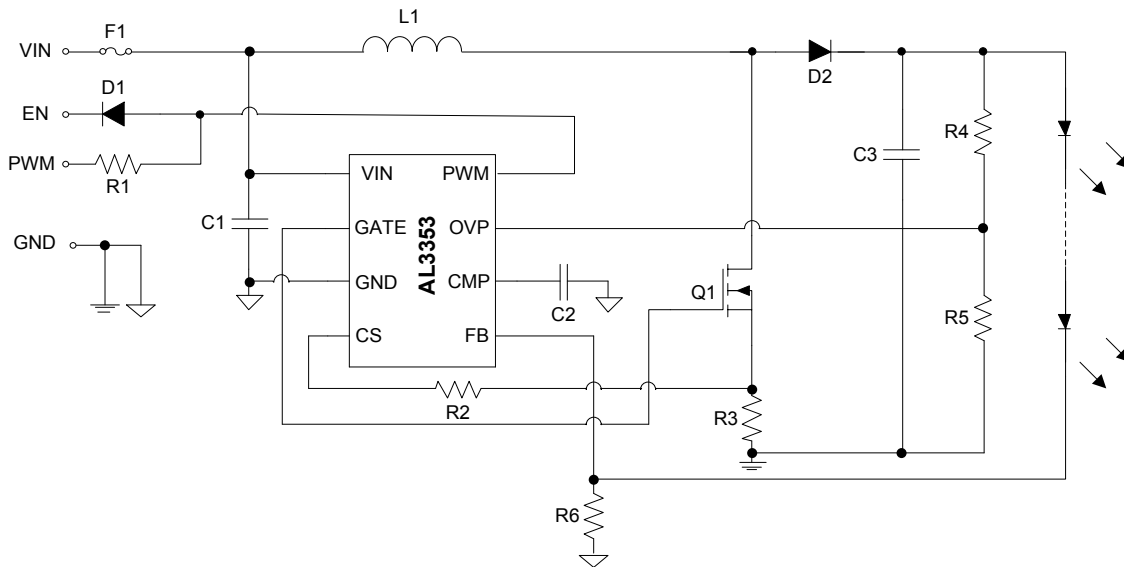

Figure 1. Typical Application Schematic

Pin Descriptions

Pin Number	Pin Name	Function
1	VIN	Power Supply Input
2	GATE	Gate Drive Output
3	GND	Ground
4	CS	Current Sense Input
5	FB	LED Current Feedback
6	COMP	Boost Converter Loop Compensation
7	OVP	Overvoltage Protection Sense
8	PWM	PWM Signal Input for Analog Dimming Control

NEW PRODUCT

Functional Block Diagram

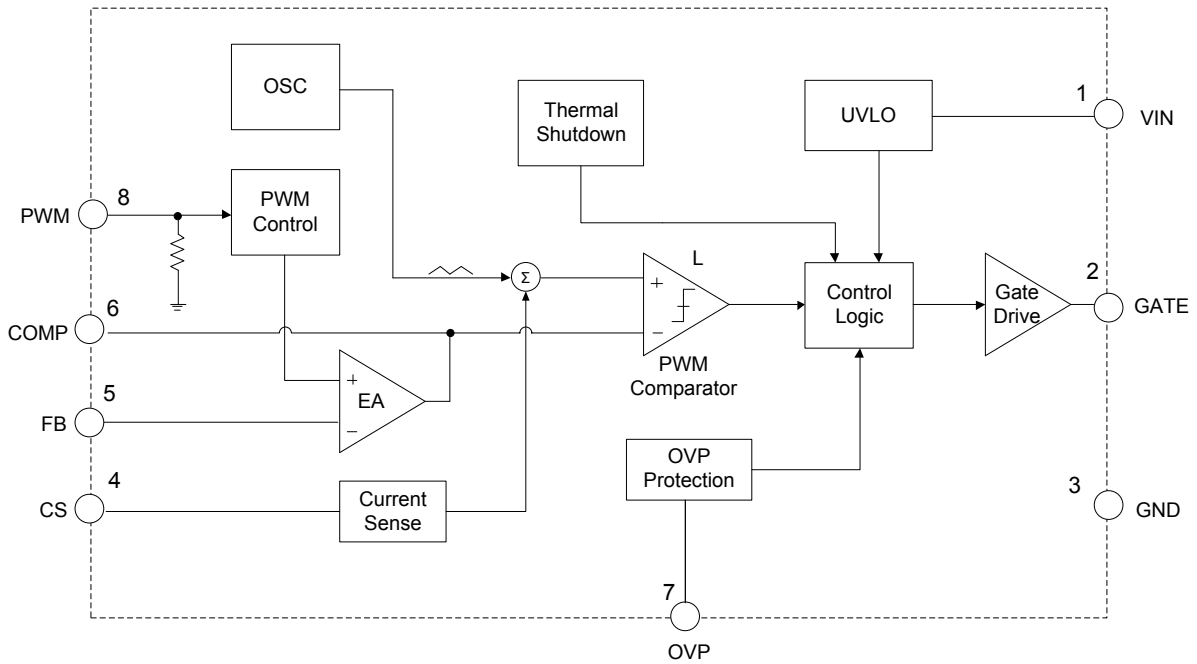

Absolute Maximum Ratings (@T_A = +25°C, unless otherwise specified. Note 4)

Symbol	Parameter	Rating	Unit
V _{IN} , V _{GATE} , V _{OVP}	V _{IN} , GATE, OVP Pin Voltage	-0.3 to 43	V
V _{CS} , V _{FB} , V _{COMP}	CS, FB, COMP Pin Voltage	-0.3 to 7	V
V _{PWM}	PWM Pin Voltage (Note 5)	-0.3 to 7	V
T _J	Operating Junction Temperature	+150	°C
T _{STG}	Storage Temperature Range	-65 to +150	°C
T _{LEAD}	Lead Temperature (Soldering, 10sec)	+260	°C
θ _{JA}	Thermal Resistance (Junction to Ambient) (Note 6)	+105	°C/W
θ _{JC}	Thermal Resistance (Junction to Case) (Note 6)	6.6	°C/W
—	ESD (Charge Device Model)	750	V
—	ESD (Human Body Model)	2000	V

- Notes:
- Stresses greater than those listed under *Absolute Maximum Ratings* can cause permanent damage to the device. These are stress ratings only and functional operation of the device at these or any other conditions beyond those indicated under *Recommended Operating Conditions* is not implied. Exposure to *Absolute Maximum Ratings* for extended periods may affect device reliability.
 - Rating value refers to DC only. For small duty cycle pulse in less than 100ns in one period (typical 8.33µs), negative spike value is relaxed to -5V.
 - Device mounted on 1" × 1" FR-4 substrate PCB, 2oz copper, with minimum recommended pad layout.

Recommended Operating Conditions

Symbol	Parameter	Min	Max	Unit
V _{IN}	V _{IN} Pin Voltage	9	40	V
f _{PWM}	PWM Frequency for Analog Dimming	5	50	kHz
T _A	Ambient Temperature	-40	+105	°C

Electrical Characteristics ($V_{IN} = 12V$, $V_{PWM} = 5V$, @ $T_A = +25^\circ C$, unless otherwise specified.) (Note 7)

Symbol	Parameter	Conditions	Min	Typ	Max	Unit
Supply Voltage						
V_{IN}	Input Voltage	—	9.0	—	40	V
I_{OP}	Operating Supply Current	$V_{IN} = 12V$, $V_{PWM} = 5V$, no load	—	2	3	mA
I_{SHDN}	Shutdown Supply Current	PWM low > 50mS, Sleep Mode	—	130	180	μA
Under Voltage Lockout						
V_{UVLO}	Input UVLO Threshold	V_{IN} Rising	7.8	8.3	8.8	V
V_{HYS}	Input UVLO Hysteresis	—	—	800	—	mV
Soft Start						
I_{SS_SLOP}	Soft Start Slope	—	—	22	—	mV/ms
Error Amplifier						
V_{FB}	Feedback Reference Voltage	Reference voltage at non-inverting input	394	400	406	mV
A_m	Open-Loop Voltage Gain	—	—	70	—	dB
G_m	Transconductance of EA	—	—	100	—	$\mu A/V$
I_{SOURCE}	Output Source Current	—	—	30	—	μA
I_{SINK}	Output Sink Current	—	—	60	—	μA
PWM to Analog Dimming Control						
—	PWM Duty	—	0	—	100	%
V_{PWM_H}	PWM Logic Input for Analog Dimming	—	2.5	—	—	V
V_{PWM_L}		—	—	—	1.2	V
Protection Threshold						
V_{OVP_OV}	Output Over Voltage Threshold Voltage	—	1.9	2.0	2.1	V
V_{OVP_UVLO}	OVP UVLO Threshold Voltage	Normal operation	—	250	—	mV
		System startup	—	150	—	mV
V_{CS_OCP}	Over Current Threshold Voltage	Duty = 90%	425	500	575	mV
V_{CS_HIGH}	CS High Protection Threshold	Diode or Inductor short	1.1	1.2	1.3	V
V_{CMP_HIGH}	COMP High-Protection Threshold	FB short to GND	2.9	3.2	3.5	V
T_{OTP}	Overtemperature Threshold	—	—	+160	—	$^\circ C$
Gate Driver						
f_{OSC}	Oscillator Frequency	—	110	120	130	kHz
D_{MAX}	Max. Duty Cycle	—	93	95	97	%
V_{GATE}	Gate Pin Output Voltage	$V_{IN} = 24V$	—	13	—	V
t_{RISE}	Rising Time	1nF load	—	40	—	ns
t_{FALL}	Falling Time		—	20	—	ns

Note: 7. These parameters, although guaranteed by design, are not 100% tested in production.

Performance Characteristics

Operating Frequency vs. Ambient Temperature

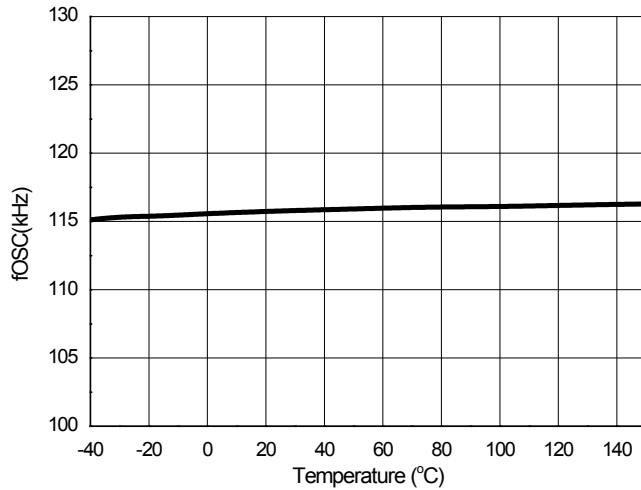

Reference Voltage vs. Ambient Temperature

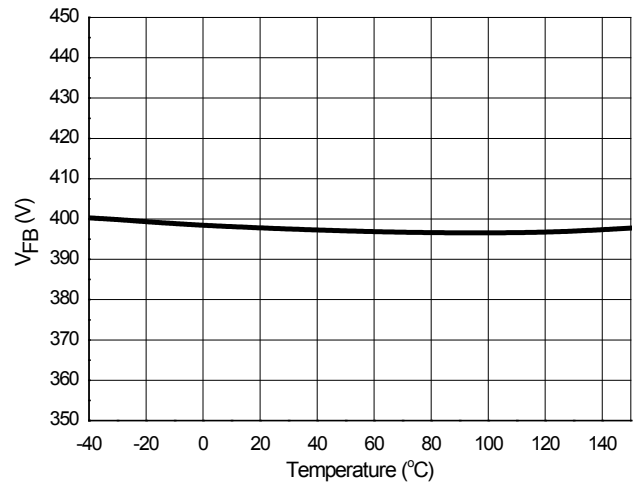

Input UVLO Threshold (VIN Rising) vs. Ambient Temperature

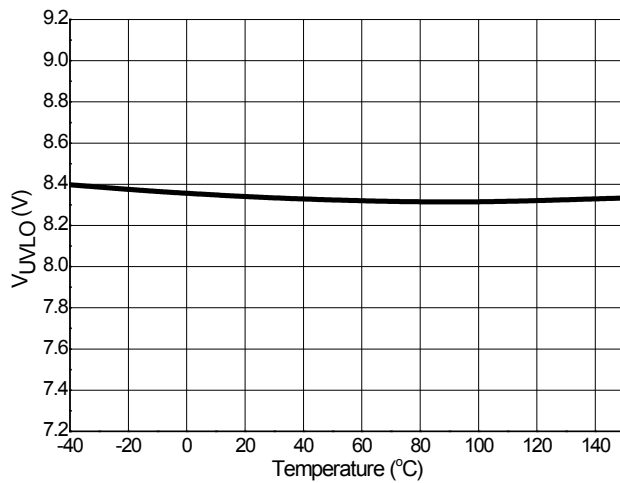

Overvoltage Threshold Voltage vs. Ambient Temperature

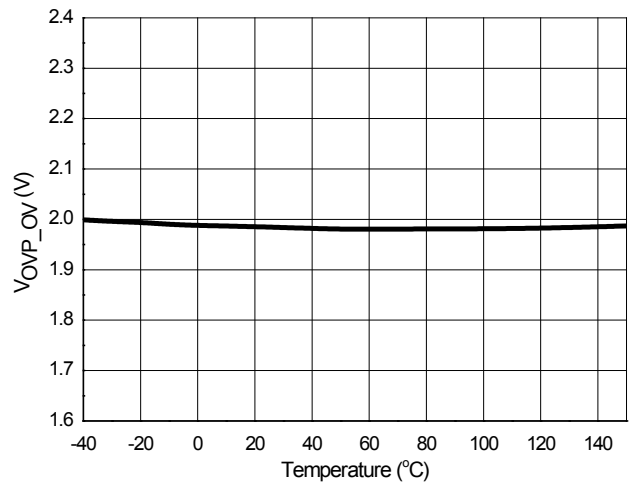

NEW PRODUCT

Performance Characteristics (continued)

NEW PRODUCT

Shutdown Supply Current vs. Ambient Temperature

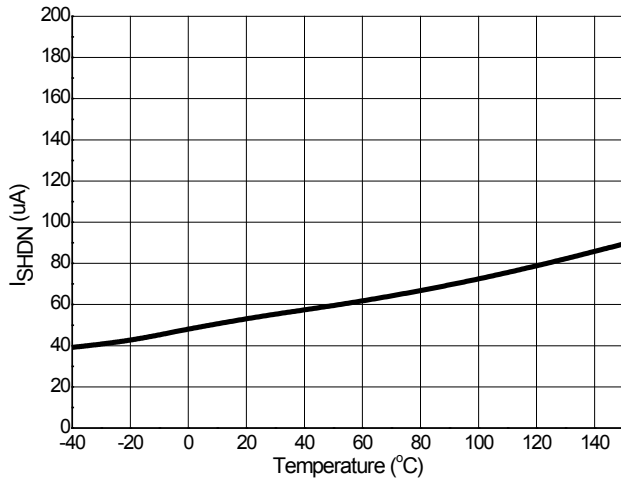

Operating Supply Current vs. Ambient Temperature

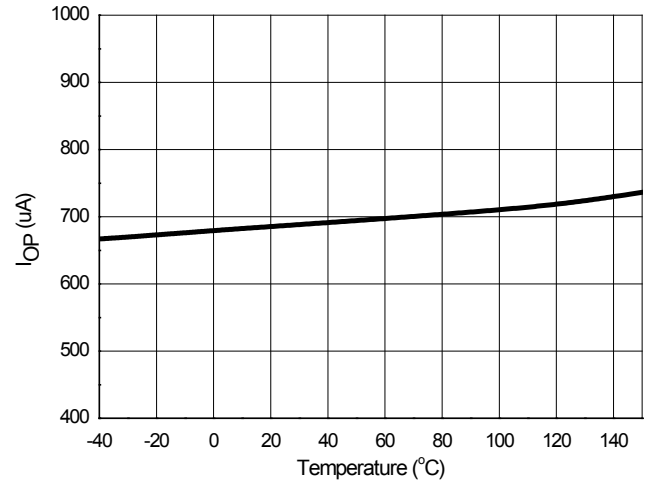

Overcurrent Threshold Voltage vs. Duty

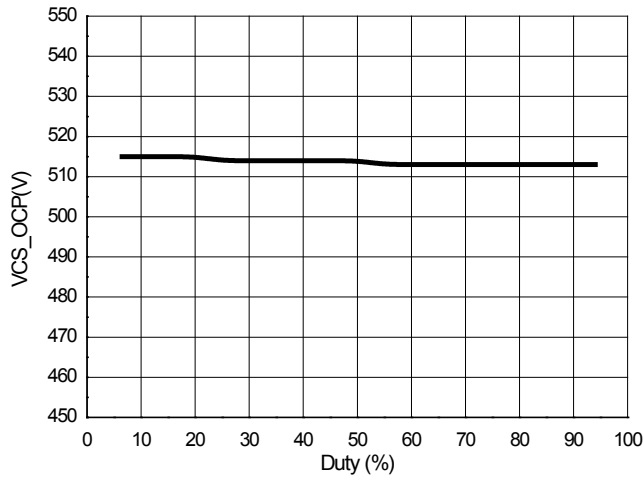

PWM-to-Analog Dimming Curve

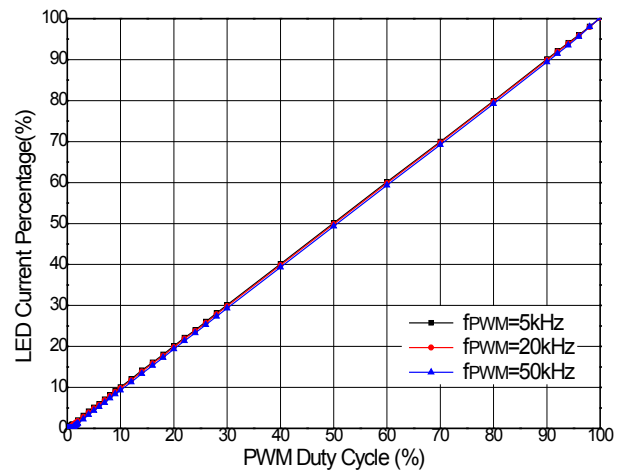

Function Description

The AL3353 is a LED driver controller designed for boost converters in a constant-frequency mode. It implements a peak-current mode control scheme and an internal transconductance amplifier to accurately control the output current over wide input and load conditions.

The AL3353 has comprehensive protection features such as power MOSFET overcurrent protection (OCP), output overvoltage protection (OVP), diode and inductor short protection, LED cathode short-to-GND protection, IC power supply undervoltage lockout (UVLO), LED open protection, V_{OUT} short protection, and overtemperature protection (OTP).

Startup

The AL3353 is enabled by applying a voltage greater than 2.5V to the PWM pin. The PWM pin is pulled down to GND with an onchip 220k Ω resistor. When the first rising edge is applied to the PWM pin, the AL3353 powers up immediately and remains powered up until the PWM input is lower than 1.3V for at least 20ms (typical). At this time, the IC enters standby mode. During standby mode, the current consumption of the AL3353 is lower than 130 μ A (typical). Once AL3353 is enabled, the internal 5V regulator is activated and consumes less than 4mA.

When PWM is active high, the AL3353 checks the topology connection first. The IC monitors the OVP pin to detect whether the Schottky diode is connected, or the boost output is short to GND. If the voltage at OVP pin is lower than 150mV, the output is disabled. The AL3353 also checks other faults (UVLO, CS high, CMP high, FB high, OCP, and OTP), and the boost converter boosts up the output with the internal soft start if no fault conditions.

UVLO

AL3353 contains an undervoltage lockout (UVLO) protection. AL3353 is not turned ON until the power supply (V_{IN}) reaches 8.3V (typical). Whenever the input voltage falls below approximately 7.5V (typical), the device is turned off. The UVLO circuit has a hysteresis of 800mV.

LED Current Regulation

The AL3353 senses the FB pin voltage to control the LED current. The error between the sensed voltage and the internal FB reference voltage is amplified and compared to the CS pin sensing current signal plus the slope compensation to determine the power MOSFET on-time. The error amplifier sources or sinks current to the COMP pin to adjust the required inductor current responding to the load changes. The slope compensation signal is added to the current-sense signal to guarantee system stability at high duty cycle.

The error amplifier reference is set by internal reference voltage and the PWM duty cycle at PWM pin. And the average LED current is approximated by Equation 1:

$$I_{LED}[\text{mA}] = \frac{400\text{mV} \cdot \text{DUTY}}{R_{FB}[\Omega]} \quad (1)$$

AL3353 enters the pulse-skip mode at light load to improve efficiency and prevent overcharging the output capacitor. AL3353 turns the GATE signal high for a minimum on time (typical 600ns) and remains low until another pulse is required to maintain the boost converter output voltage.

Dimming Control

The LED current is controlled by the external PWM signal with different duty cycles. The AL3353 can support PWM signals with a frequency ranging from 5kHz to 50kHz, and the PWM signal must be higher than 2.5V for high logic and lower than 1.3V for low logic. With a duty cycle same as the external PWM signal, an internal square wave is filtered to provide reference voltage of EA input, which determines the FB reference.

Function Description (continued)

Slope Compensation

The AL3353 adopts a peak-current mode control scheme. The main advantages of current mode are inherent cycle-by-cycle current limit of the power MOSFET and simple control-loop characteristics. However, current-mode control can cause the subharmonic oscillation for duty cycles greater than 50%, leading to system instability. The AL3353 has a build-in slope compensation to avoid the subharmonic oscillation.

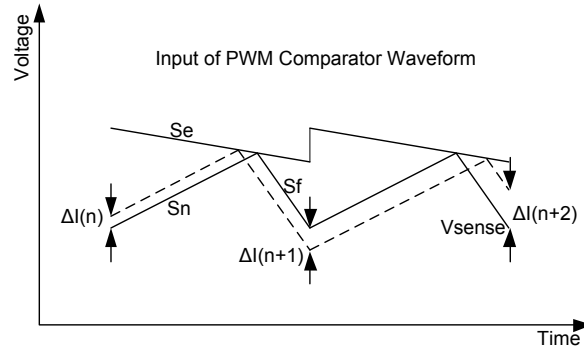

Figure 2 Subharmonic Oscillation at Duty >50% and Compensation Slope to Avoid Subharmonic Oscillation

In Figure 2, $\Delta I(n)$, $\Delta I(n+1)$, and $\Delta I(n+2)$ represent the inductor current increments when there is disturbance in the inductor current. The relationship of the inductor current increment can be calculated with Equation 2.

$$\Delta I_{(n+1)} = \frac{S_f - S_e}{S_n + S_e} \cdot \Delta I_{(n)} \quad (2)$$

Where:

- S_n is the slope of the inductor current when rising
- S_f is the slope of the inductor current when falling
- S_e is the slope of control signal.

If the control signal has no compensation, the inductor current ramps up until the slope reaches the control signal and then ramps down. If the PWM duty is higher than 50%, the distribution is not converged from duty to duty, and the system runs into subharmonic oscillation. To avoid subharmonic oscillation, a control compensation is required, and $(S_f - S_e) / (S_n + S_e)$ must always be smaller than 1. For boost applications, the slopes S_e , S_f , and S_n can be calculated with the following equations:

$$S_e = V_{SL} \cdot f_s \quad (3)$$

$$S_f = R_{sen} \cdot (V_{OUT} - V_{IN}) / L \quad (4)$$

$$S_n = R_{sen} \cdot V_{IN} / L \quad (5)$$

Where R_{sen} is the current sense resistance and typical value of V_{SL} is 100mV.

From the equations, the factor $(S_f - S_e) / (S_n + S_e)$ decreases if S_e increases. When the duty cycle is greater than 50%, lower inductance can also result in the factor increase. For more flexibility, slope compensation amplitude can be increased by adding one external resistor, R_{SL} , in the CS path. Figure 3 shows the circuit setup. The externally generated slope compensation is then added to the internal slope compensation of the AL3353. When using external slope compensation, the equation for S_e becomes:

$$S_e = (V_{SL} + I_S \cdot R_{SL}) \cdot f_s \quad (6)$$

Where I_S typical value is 50 μ A.

Function Description (cont.)

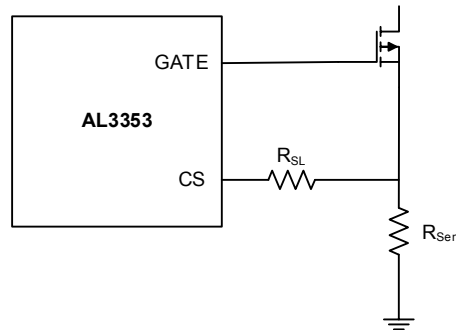

Figure 3. Adding External Slope Compensation

A best practice is to only add as much slope compensation as necessary to avoid subharmonic oscillation. Additional slope compensation minimizes the influence of the sensed current in the control loop. With very large slope compensation, the control loop characteristics are similar to a voltage mode regulator, which compares the error voltage to a saw tooth waveform rather than the inductor current.

LED Open Protection

AL3353 shuts down the output if the output voltage is higher than the preset threshold level. When LED failure happens, the LED current and the resulted voltage drop on sensing resistor is nearly zero; the converter runs at a maximum duty cycle that boosts the output voltage to a very high level. To prevent this from happening, the output voltage is monitored through the OVP pin, and the converter is shut down if the output voltage exceeds the preset level. This protection is latched and AL3353 can be reset from VIN or PWM.

LED Cathode Short-to-GND Protection

When the LED cathode is short to GND, the output voltage increases to the OVP voltage, and IC turns off the GATE signal. However in some conditions, if the output power is limited by the OCP protection before the output voltage reaches the OVP voltage, the GATE never turns off. In this case, large current goes through both the power MOSFET and Schottky diode and leads to damages. To enhance safety, the AL3353 monitors the voltage on the COMP pin and latches the GATE signal if the COMP voltage is continuously greater than 3.2V for 37ms.

Diode and Inductor Short Protection

When the Schottky diode or the inductor is short, the current of the power MOSFET increases significantly, which would cause the MOSFET damage if the IC continues working. AL3353 monitors the voltage on the CS pin cycle by cycle. If the CS pin voltage is greater than 1.2V (typical) for continuous 17 cycles, the IC latches and shuts down the GATE output to prevent the MOSFET from permanent damage.

V_{OUT} Short Protection

V_{OUT} short condition is monitored by the voltage at OVP pin. In normal operation, when the OVP voltage drops below a threshold of approximately 0.25V (typical), V_{OUT} short protection is triggered, and the GATE turns off. This state is latched and can be reset from VIN or PWM.

Thermal Shut Down

The AL3353 includes a thermal protection circuit to ensure that the system does not run into condition of thermal runaway and blow up. When the junction temperature exceeds +160°C (typical), the controller and current sources latch shutdown.

Application Information

The AL3353 is a highly integrated and cost-effective LED controller optimized for LCD monitor and LCD TV backlighting application. It provides a high-performance LED backlight solution with low-BOM cost.

To build a boost converter with AL3353, several configurations are required. The LED current, OCP, and OVP must be set with corresponding resistors; a proper inductor, power MOSFET and Schottky diode must be selected.

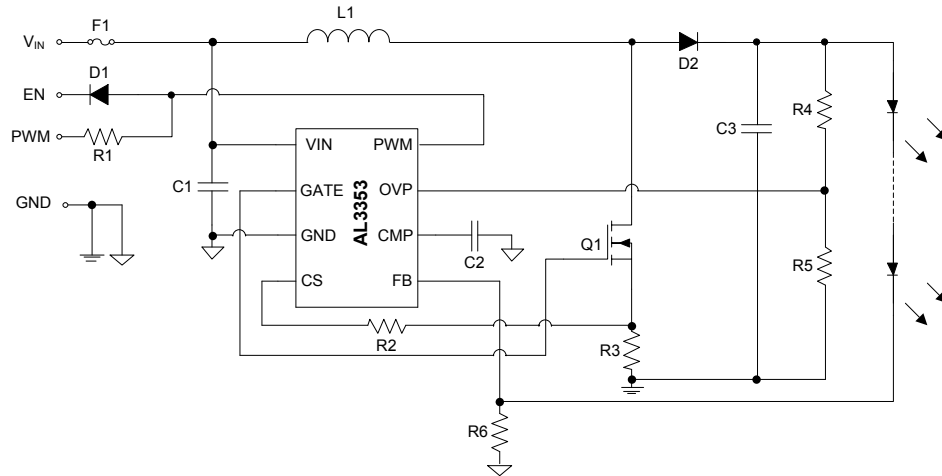

Figure 4. Typical Circuit Schematic of AL3353 LED Driver Application

LED Current Setting

The LED current is controlled by the feedback resistor (R6 in Figure 4). LED current accuracy is determined by the regulator's feedback threshold accuracy and is independent of the LED's forward voltage variation. So, precision resistors are preferred.

$$I_{LED} = \frac{400mV}{R_{FB}} \text{ (mA)} \quad (7)$$

Inductor Design

An inductor is the energy storage component in a converter. Designing an inductor means specifying its size, structure, material, inductance, saturation level, dc-resistance (DCR), and core loss. In a boost converter, inductance has a direct impact on the inductor ripple current. The peak-to-peak inductor ripple current can be calculated as:

$$I_{P-P} = \frac{V_{IN} \cdot (V_{OUT} - V_{IN})}{V_{OUT} \cdot L \cdot f} \quad (8)$$

Where

- V_{IN} is the input voltage
- V_{OUT} is the output voltage
- f is the switching frequency
- L is the inductance

The boost converter average inductor current can be calculated with Equation 9 where η is the converter efficiency. The inductor current ripple rate is defined with Equation 10.

$$I_L = \frac{I_{LED} \cdot V_{OUT}}{V_{IN} \cdot \eta} \quad (9)$$

$$\gamma = \frac{I_{P-P}}{I_L} \quad (10)$$

Higher inductance means lower-ripple current, lower RMS (root mean square) current, lower voltage ripple on both input and output, and higher efficiency unless the resistive loss of the inductor dominates the overall loss. However, higher inductance also means a bigger inductor size and a slower response to transients. For optimal practical design, the inductor current ripple rate γ is set 0.3 to 0.5.

Application Information (cont.)

The saturation level is another important parameter in designing inductor. The maximum peak inductor current can be calculated with Equation 11:

$$I_{PK} = \frac{I_{LED} \cdot V_{OUT}}{V_{IN} \cdot \eta} + \frac{I_{P-P}}{2} \quad (11)$$

The inductor saturation current should be higher than the inductor peak current with a reasonable margin.

Considering the system efficiency, cost requirements and the peak inductor current limitations, an inductor is then designed accordingly.

OCP Setting

To protect the power MOSFET from overcurrent and other anomalies, AL3353 integrates an overcurrent protection (OCP) function. AL3353 senses the CS pin voltage and enters the OCP protection when the threshold voltage is touched. The OCP current should be set 30%, which is higher than the maximum peak inductor current at the lowest input voltage and full load output. The OCP resistor (R3 in Figure 4) sets the desired OCP current with the Equation 12.

$$R_{OCP} = \frac{500mV}{I_{OCP}} \quad (12)$$

OVP Setting

AL3353 shuts down the output if the output voltage is higher than the preset output threshold voltage. The threshold voltage must be set higher than the nominal output voltage with at least 20% margin to avoid mis-trigger. The threshold voltage is set by a resistor divider (R4 and R5 in Figure 4) with Equation 13.

$$V_{OUT_OVP} = \frac{R_4 + R_5}{R_5} \cdot 2V \quad (13)$$

The output threshold voltage cannot be set too high of a voltage because the AL3353 monitors the OVP pin voltage during start up and shuts the system if OVP pin voltage is lower than 150mV.

MOSFET Selection

To select a proper power MOSFET a few key parameters are considered, such as the drain-source breakdown voltage (BV_{DSS}), on-resistance ($R_{DS(ON)}$), and package type (i.e. TO-220, TO-252, etc.). The MOSFET BV_{DSS} should be higher than the OVP voltage with 20% margin, since the MOSFET stress voltage when OVP is exactly the output voltage. The package of a power MOSFET greatly affects its thermal performance, a TO-252 (DPAK) package is recommended for typical applications. A low $R_{DS(ON)}$ MOSFET is beneficial for both system efficiency and the MOSFET thermal performance, but lower $R_{DS(ON)}$ usually means higher cost. Taking the peak inductor current and RMS current into account, a trade-off of system efficiency, thermal performance, and cost is required for selection.

Diode Selection

To maximize converter efficiency, the use of a Schottky diode is strongly recommended. In a boost converter, the average forward current of the rectifier diode I_F is equal to the output current I_{OUT} .

$$I_F = I_{OUT} \quad (14)$$

In practical application diode selection, the forward current rating should be at least 3 times the LED current.

The peak repetitive reverse voltage (V_{RRM}) of the diode must be higher than the OVP voltage with at least 20% margin because the stress voltage when OVP is exactly the output voltage. A low forward drop diode is preferable for its efficiency advantages and low power dissipation of the diode.

Constant Voltage Application

Besides boost converter for LED driver applications, the AL3353 can also be applied in constant output voltage boost applications. Figure 5 shows the typical circuit schematic for constant voltage applications.

Application Information (cont.)

To make the output voltage constant, a resistor divider (R6 and R7) is added, and the FB pin is connected to sense the divided output voltage. The output voltage V_{OUT} is set with Equation 15.

$$V_{OUT} = \frac{R_6 + R_7}{R_7} \cdot 0.4V \tag{15}$$

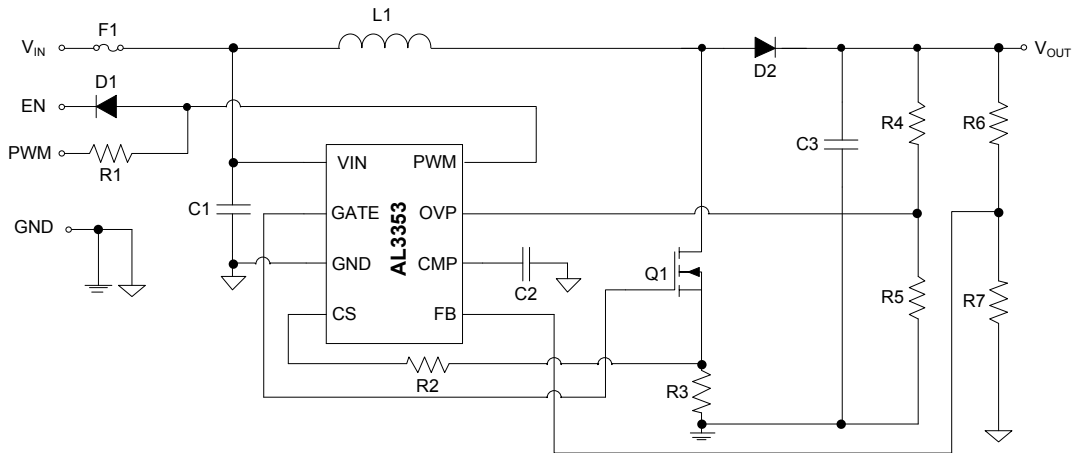

Figure 5. Typical Circuit Schematic of AL3353 Constant Output Voltage Application

For the OCP setting, OVP setting, inductor design, power MOSFET selection and Schottky diode selection, the above configuration guides for LED driver are also applicable.

Layout Guide

The PCB layout is critical for the optimal performance of the boost converter design. A good PCB layout is fundamental to correct operation and high performance of the converter. The EMI performance is especially dependent on the PCB layout. So, the following important guidelines should be followed:

1. The traces of the power loops must be wide and short, and the power components must be placed close together to make the loop area as small as possible. There are two high-current power loops in the converter. One is the high-current input loop, and the other is the high-current output loop. The high-current input loop goes from the positive terminal of the CIN to the inductor, to the MOSFET, to the current-sense resistor, and then to the negative terminal of CIN. The high-current output loop goes from the positive terminal of the CIN to the inductor, to the diode, to the positive terminal of the COUT, reconnecting between the COUT, and the CIN ground terminals.

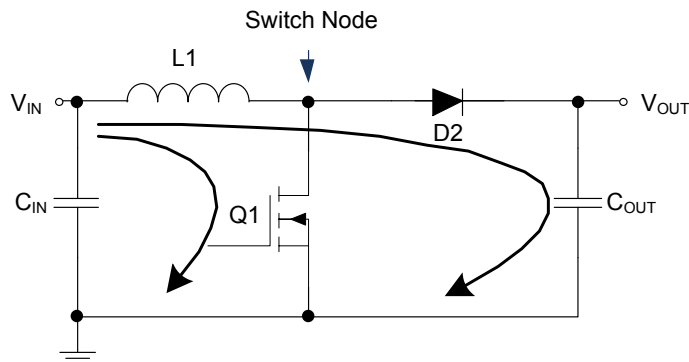
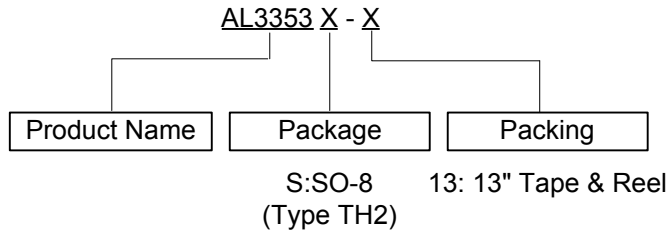

Figure 6. The Power Loops of a Boost Converter

2. A decoupling capacitor of the VIN pin is recommended, and it should be placed as close as possible to the pin to reduce the noise on the power source for the internal logic circuit.
3. To keep the gate signal clean, the gate driving trace must be placed away from the inductor because the alternating magnetic field is the primary noise source in a switching converter
4. For the OVP resistor divider, both resistors must be placed close to the IC, and the divider must be grounded close to the IC ground.
5. For the compensation capacitor, it should be placed as close as possible to the COMP pin.
6. Copper area of the power loop, especially around the switching node, must be as big as possible for good thermal performance.

Ordering Information



Part Number	Package Code	Package	13" Tape and Reel	
			Quantity	Part Number Suffix
AL3353S-13	S	SO-8 (Type TH2)	4000/Tape & Reel	-13

Marking Information

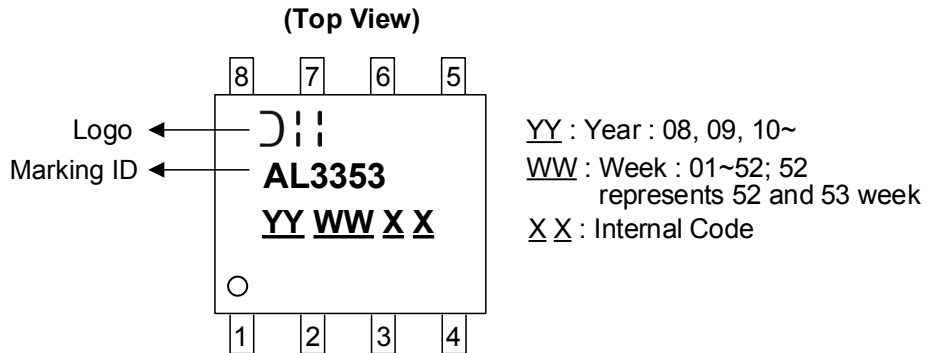

NEW PRODUCT

Package Outline Dimensions (All dimensions in mm(inch).)

Please see <http://www.diodes.com/package-outlines.html> for the latest version.

SO-8 (Type TH2)

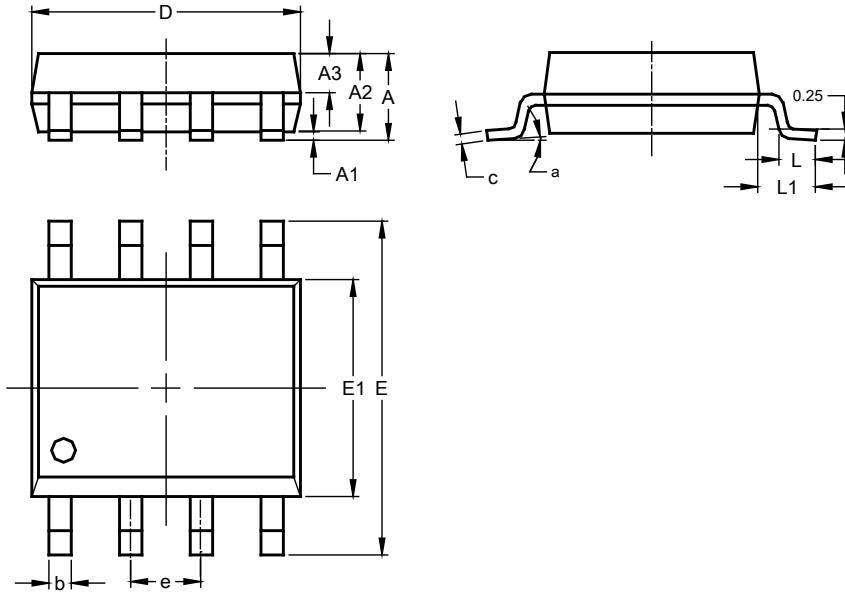

SO-8 (Type TH2)			
Dim	Min	Max	Typ
A	—	1.75	—
A1	0.10	0.225	—
A2	1.30	1.50	1.40
A3	0.60	0.70	0.65
b	0.39	0.47	—
c	0.20	0.24	—
D	4.80	5.00	4.90
E	5.80	6.20	6.00
E1	3.80	4.00	3.90
e	1.27BSC		
h	0.25	0.50	—
L	0.50	0.80	—
L1	1.05REF		
Ø	0°	8°	—
All Dimensions in mm			

Suggested Pad Layout

Please see <http://www.diodes.com/package-outlines.html> for the latest version.

SO-8 (Type TH2)

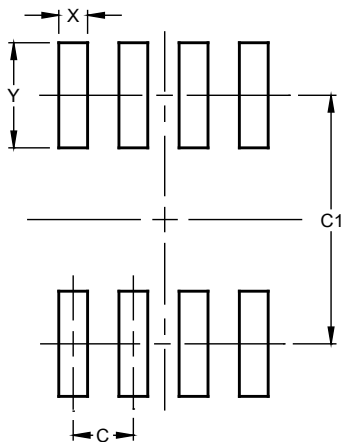

Dimensions	Value (in mm)
C	1.27
C1	5.20
X	0.60
Y	2.20

IMPORTANT NOTICE

DIODES INCORPORATED MAKES NO WARRANTY OF ANY KIND, EXPRESS OR IMPLIED, WITH REGARDS TO THIS DOCUMENT, INCLUDING, BUT NOT LIMITED TO, THE IMPLIED WARRANTIES OF MERCHANTABILITY AND FITNESS FOR A PARTICULAR PURPOSE (AND THEIR EQUIVALENTS UNDER THE LAWS OF ANY JURISDICTION).

Diodes Incorporated and its subsidiaries reserve the right to make modifications, enhancements, improvements, corrections or other changes without further notice to this document and any product described herein. Diodes Incorporated does not assume any liability arising out of the application or use of this document or any product described herein; neither does Diodes Incorporated convey any license under its patent or trademark rights, nor the rights of others. Any Customer or user of this document or products described herein in such applications shall assume all risks of such use and will agree to hold Diodes Incorporated and all the companies whose products are represented on Diodes Incorporated website, harmless against all damages.

Diodes Incorporated does not warrant or accept any liability whatsoever in respect of any products purchased through unauthorized sales channel. Should Customers purchase or use Diodes Incorporated products for any unintended or unauthorized application, Customers shall indemnify and hold Diodes Incorporated and its representatives harmless against all claims, damages, expenses, and attorney fees arising out of, directly or indirectly, any claim of personal injury or death associated with such unintended or unauthorized application.

Products described herein may be covered by one or more United States, international or foreign patents pending. Product names and markings noted herein may also be covered by one or more United States, international or foreign trademarks.

This document is written in English but may be translated into multiple languages for reference. Only the English version of this document is the final and determinative format released by Diodes Incorporated.

LIFE SUPPORT

Diodes Incorporated products are specifically not authorized for use as critical components in life support devices or systems without the express written approval of the Chief Executive Officer of Diodes Incorporated. As used herein:

A. Life support devices or systems are devices or systems which:

1. are intended to implant into the body, or
2. support or sustain life and whose failure to perform when properly used in accordance with instructions for use provided in the labeling can be reasonably expected to result in significant injury to the user.

B. A critical component is any component in a life support device or system whose failure to perform can be reasonably expected to cause the failure of the life support device or to affect its safety or effectiveness.

Customers represent that they have all necessary expertise in the safety and regulatory ramifications of their life support devices or systems, and acknowledge and agree that they are solely responsible for all legal, regulatory and safety-related requirements concerning their products and any use of Diodes Incorporated products in such safety-critical, life support devices or systems, notwithstanding any devices- or systems-related information or support that may be provided by Diodes Incorporated. Further, Customers must fully indemnify Diodes Incorporated and its representatives against any damages arising out of the use of Diodes Incorporated products in such safety-critical, life support devices or systems.

Copyright © 2019, Diodes Incorporated

www.diodes.com

Looking for pricing, stock, or lifecycle information?

Click below to explore more details on WIN SOURCE:

- ⊖ [View AL3353S-13 on WIN SOURCE](#)
- ⊖ [Diodes Incorporated Information](#)

Optimize Your Supply Chain with WIN SOURCE Solutions

- ✓ Global Sourcing Solution
- ✓ Obsolete Management
- ✓ Cost Control Management
- ✓ Shortage Management
- ✓ Alternative Solution
- ✓ Excess Inventory Management