



**THE DATASHEET OF
AL1673-20CSP-13**



Description

The AL1673 is a high performance single stage Flyback/Buck-Boost converter, targeting dimmable LED lighting application. It is operating at BCM mode which results in good EMI and efficiency.

The AL1673 can support multiple dimming modes. When a 0.3~2.4V DC signal is applied on APWM pin, the device will operate in analog dimming mode. When a digital signal is applied on APWM pin, the device works at PWM dimming mode.

The AL1673 features low start-up current and low operation current. It integrates multiple protections including over voltage, short circuit, over current and over temperature protection. It also integrates 600V/2A high voltage MOSFET.

The AL1673 is available in SO-8EP package.

Features

- Valley Switching for Low Switching Loss
- Low Start-Up Current
- High PF and Low THD
- High Efficiency
- Tight LED Current Variation Range
- Tight Output Open Voltage Variation Range
- Integrates 600V/2A MOSFET
- Support Both PWM Dimming and Analog Dimming
 - PWM Dimming Range:3% to 100% at 1kHz PWM Frequency
 - Analog Dimming and PWM-to-DC Dimming Range:18% to 100%;
- Internal Protections
 - Under Voltage Lock Out (UVLO)
 - Output Over Voltage Protection (OVP)
 - Output Short Protection (OSP)
 - Over Current Protection (OCP)
 - Thermal Fold-back Protection (TFP)
 - Over Temperature Protection (OTP)
- Low System Cost
- Package: SO-8EP
- **Totally Lead-Free & Fully RoHS Compliant (Notes 1 & 2)**
- **Halogen and Antimony Free. "Green" Device (Note 3)**

Notes:

1. No purposely added lead. Fully EU Directive 2002/95/EC (RoHS) & 2011/65/EU (RoHS 2) compliant.
2. See http://www.diodes.com/quality/lead_free.html for more information about Diodes Incorporated's definitions of Halogen- and Antimony-free, "Green" and Lead-free.
3. Halogen- and Antimony-free "Green" products are defined as those which contain <900ppm bromine, <900ppm chlorine (<1500ppm total Br + Cl) and <1000ppm antimony compounds.

Pin Assignments

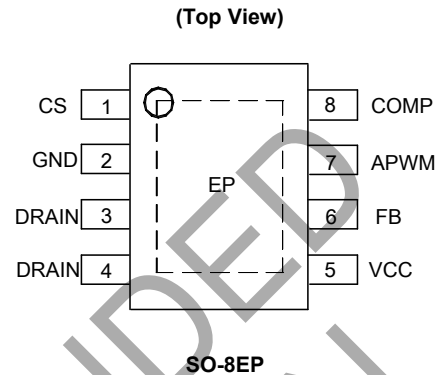

Applications

- General LED Lighting Driver with Dimming Function
- General Purpose Constant Current Source
- Smart LED Lighting

Typical Applications Circuit

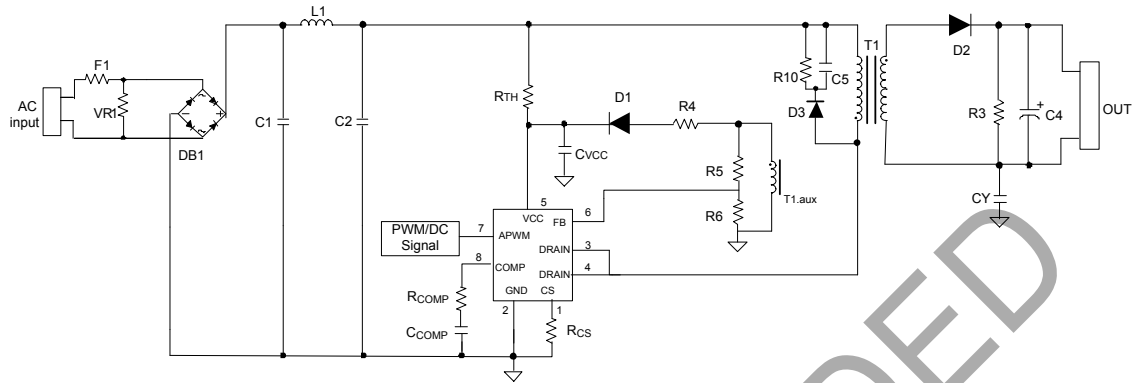

AL1673 Flyback Application Circuit

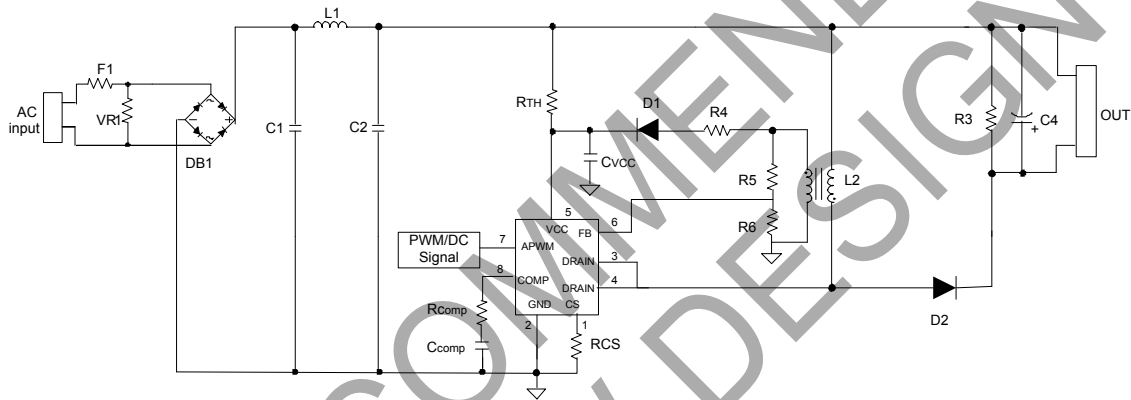

AL1673 Buck-Boost Application Circuit

Pin Descriptions

Pin Number	Pin Name	Function
1	CS	Current sense pin, connect this pin to the source of the primary switch
2	GND	Ground
3,4	DRAIN	Drain of internal MOS
5	VCC	Supply voltage of gate driver and control circuits of the IC
6	FB	The feedback voltage sensing from the auxiliary winding
7	APWM	Analog dimming input pin or PWM signal input pin in PWM dimming mode
8	COMP	Loop compensation pin
9	Exposed Pad	Drain of internal MOS

Absolute Maximum Ratings (@ $T_A = +25^\circ\text{C}$, unless otherwise specified.) (Note 4)

Symbol	Parameter	Rating	Unit
V_{CC}	Power Supply Voltage	-0.3 to 30	V
V_{CS}	Voltage at CS to GND	-0.3 to 7	V
V_{FB}	FB Input	-0.3 to 7	V
V_{COMP}	Loop Compensation Pin	-0.3 to 7	V
V_{DRAIN}	Drain Voltage of Internal MOS	600	V
I_{DS}	Continuous Drain Current $T_C = +25^\circ\text{C}$	2	A
V_{APWM}	Voltage at APWM to GND	-0.3 to 7	V
T_J	Operating Junction Temperature	-40 to +150	$^\circ\text{C}$
T_{STG}	Storage Temperature	-65 to +150	$^\circ\text{C}$
T_{LEAD}	Lead Temperature (Soldering, 10 sec)	+300	$^\circ\text{C}$
P_D	Power Dissipation at $T_A = +50^\circ\text{C}$ (Note 5)	1.53	W
θ_{JA}	Thermal Resistance Junction-to-Ambient (Note 5)	65	$^\circ\text{C}/\text{W}$
θ_{JC}	Thermal Resistance (Junction to Case) (Note 5)	22.4	$^\circ\text{C}/\text{W}$
-	ESD (Human Body Model)	2000	V
	ESD (Machine Model)	200	V

- Note:
- Stresses greater than those listed under "Absolute Maximum Ratings" may cause permanent damage to the device. These are stress ratings only, and functional operation of the device at these or any other conditions beyond those indicated under "Recommended Operating Conditions" is not implied. Exposure to "Absolute Maximum Ratings" for extended periods may affect device reliability. All voltages unless otherwise stated and measured with respect to GND.
 - Device mounted on 2"x2" FR-4 substrate PCB, 2oz copper, with minimum recommended pad layout.

Recommended Operating Conditions (@ $T_A = +25^\circ\text{C}$, unless otherwise specified.)

Symbol	Parameter	Min	Max	Unit
T_A	Ambient Temperature (Note 6)	-40	+105	$^\circ\text{C}$

- Note:
- The device may operate normally at $+125^\circ\text{C}$ ambient temperature under the condition not trigger temperature protection.

Electrical Characteristics (@T_A = +25°C, unless otherwise specified.)

Symbol	Parameter	Condition	Min	Typ	Max	Unit
UVLO Section						
Startup Threshold Voltage	V _{CC_TH}	-	17	18.5	20	V
Minimal Operating Voltage	V _{OPR_MIN}	After Turn On	7	7.8	8.5	V
V _{CC} OVP Voltage	V _{CC_OVP}	-	25	27	29.9	V
Standby Current Section						
Startup Current	I _{ST}	V _{CC} = V _{CC_TH} - 0.5V, Before start up	-	0.8	-	μA
Operating Current	I _{CC}	FB CS connect to GND, C _{GATE} =100pF	-	1	-	mA
Shunt Current in OVP Mode	I _{CC_OVP}	V _{CC} >V _{CC_OVP}	3	5	7	mA
Switch Time Parameter						
Maximum On Time	T _{ON_MAX}	-	-	25	-	μs
Maximum Off Time	T _{OFF_MAX}	-	-	35	-	μs
Minimum Off Time	T _{OFF_MIN}	-	1	2	6	μs
Maximum Frequency	F _{MAX}	-	120	150	230	kHz
Internal CS reference						
Internal Reference Voltage	V _{REF}	-	0.291	0.3	0.309	V
Primary Current Clamp Voltage	V _{CS_OCP}	-	1.1	1.2	1.3	V
Error Amplifier						
G _m	G _m Trans-Conductance	-	10	16.7	22	μA/V
I _{SOURCE}	Amplifier Source Current	-	7	10	15	μA
Feedback Input Section						
FB CV Threshold	V _{FB_CV}	-	1.4	1.5	1.6	V
APWM Section						
PWM Dimming low Threshold Voltage	V _{APWM_L}	-	-	0.3	-	V
PWM Dimming High Threshold Voltage	V _{APWM_H}	-	-	2.4	-	V
Linear Dimming Range on APWM	-	-	0.3	-	2.4	V
Internal High Voltage MOSFET						
R _{DS(ON)}	Drain-Source on State Resistance	-	-	3.4	-	Ω
V _{DS}	Drain-source Break-down Voltage	-	600	-	-	V
I _{DSS}	Drain-source Leakage Current	V _{DS} = 600V ,V _{GS} =0V	-	-	1	μA
Thermal Fold-back Section						
Thermal Foldback Temperature (Note 7)	T _{REG}	-	-	+145	-	°C
Over Temperature Protection Section						
Shutdown Temperature (Notes 7&8)	-	-	-	+165	-	°C

Notes: 7. These parameters, although guaranteed by design, are not 100% tested in production.

8. The device will latch when OTP happens and the device won't operate constantly at this temperature.

Performance Characteristics (Note 9)

Startup Threshold Voltage vs. Ambient Temperature

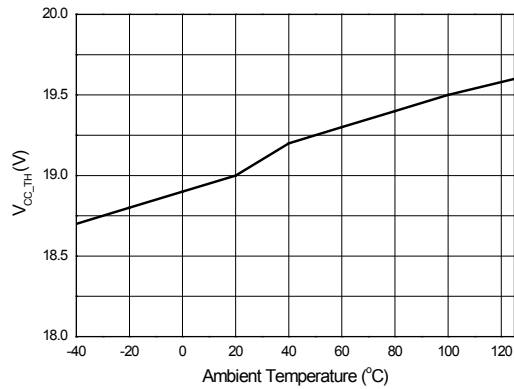

Minimum Operating Voltage vs. Ambient Temperature

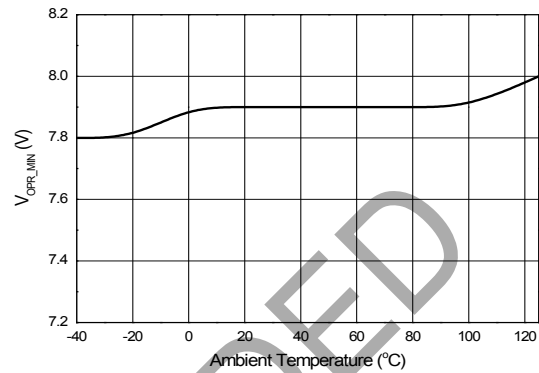

Operating Current vs. Ambient Temperature

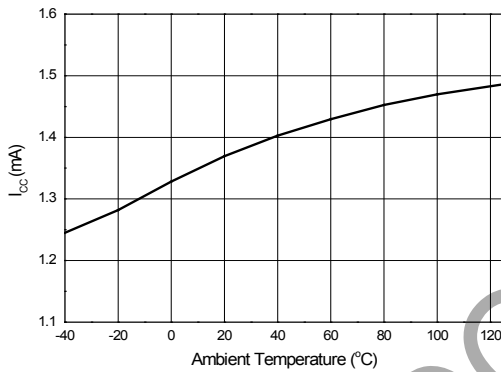

FB CV Threshold vs. Ambient Temperature

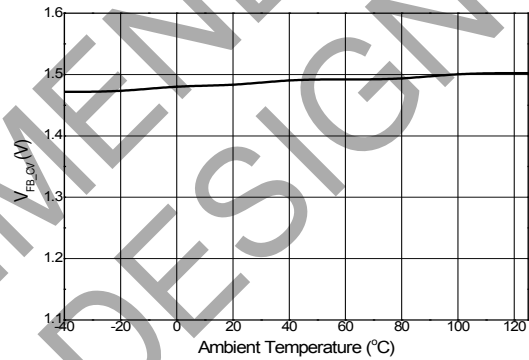

Internal Reference Voltage vs. Ambient Temperature

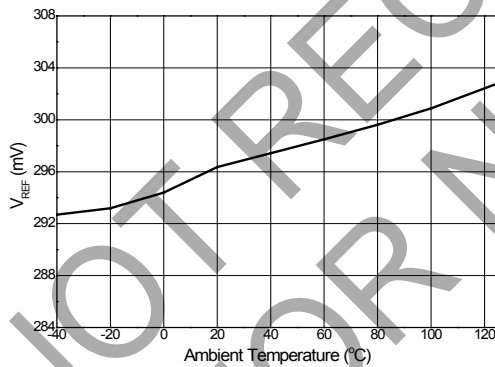

FB CV Threshold vs. V_{CC} Voltage

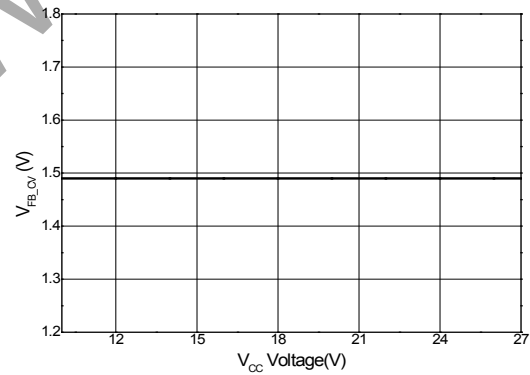

Internal Reference Voltage vs. V_{CC} Voltage

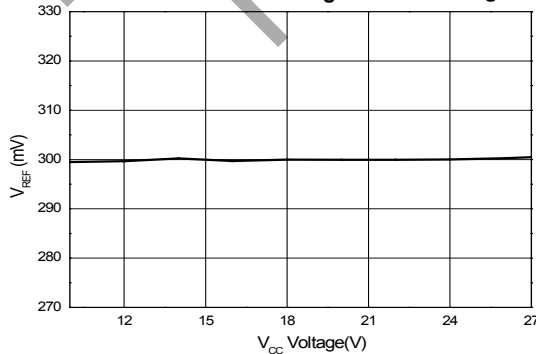

Note: 9. These electrical characteristics are tested under DC condition. The ambient temperature is equal to the junction temperature of the device.

Functional Description and Application Information

The AL1673 is a constant current high PF Flyback/Buck-boost converter with primary side regulation (PSR) control, targeting LED lighting applications. The device integrates 600V/2A high voltage MOSFET, and eliminates the opto-couplers or the secondary feedback circuits, which will help to cost down the whole system. High power factor is achieved by constant on time operation. In order to reduce the switching losses and improve EMI performance, quasi-resonant switching mode is applied. The AL1673 integrates multiple protections including UVLO protection, V_{CC} over voltage protection, output open voltage protection, over current protection, thermal fold-back protection and over temperature protection. AL1673 can support multiple dimming modes including analog dimming mode and PWM dimming.

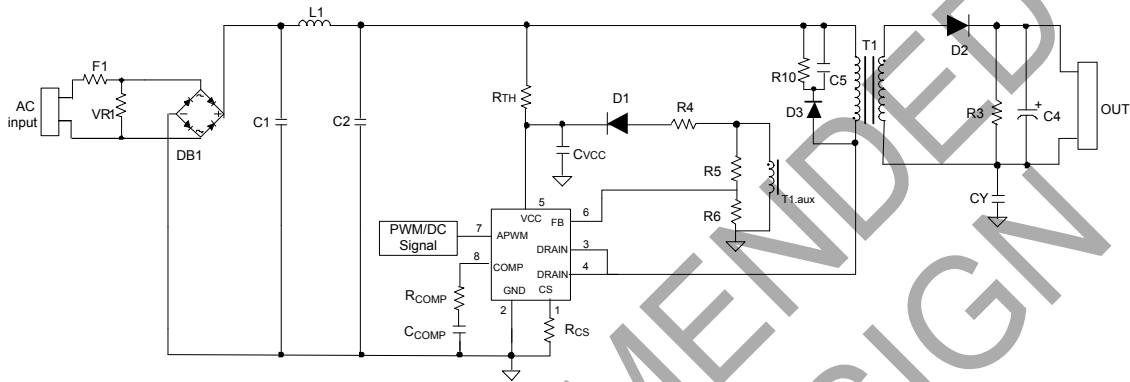

Figure.1 AL1673 Flyback Application Circuit

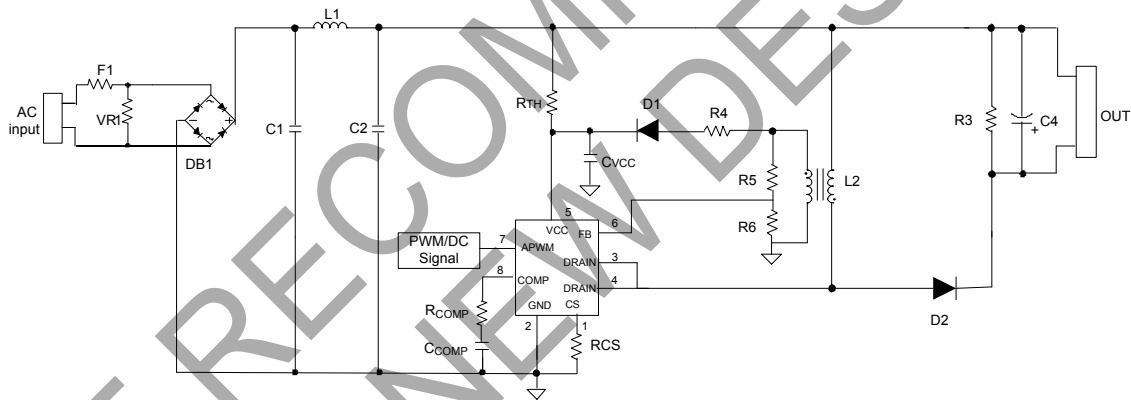

Figure.2 AL1673 Buck-Boost Application Circuit

Start-Up

After AC supply is powered on, the capacitor C_{VCC} across VCC and GND pin will be charged up by BUS voltage through a start-up resistor R_{TH} . Once V_{CC} reaches V_{CC_TH} , the internal blocks start to work. V_{CC} will be supplied by V_{BUS} until the auxiliary winding of Flyback transformer could supply enough energy to maintain V_{CC} above V_{OPR_MIN} . If V_{CC} voltage is lower than V_{OPR_MIN} switch will be turned off.

After V_{CC} exceeds V_{CC_TH} , the drive block won't start to switch on/off signals until V_{COMP} is over the initial voltage V_{COMP_ST} which can be programmed by R_{COMP} . The formula is shown as below. Such design can program startup on time to reduce the startup time or reduce the output overshoot current.

$$V_{COMP_ST} = 1.4V - 700\mu A \cdot R_{COMP} \quad \text{----- (1)}$$

Where V_{COMP_ST} is the pre-charged voltage of COMP pin, R_{COMP} is shown as Figures 1 and 2.

Generally, a big capacitance of C_{COMP} is necessary to achieve high power factor and stabilize the system loop (1 μ F to 2 μ F is recommended). The pre-charged voltage in start-up procedure can be programmed by R_{COMP} .

Functional Description and Application Information (Cont.)

Protections

1. Output Open Protection (OVP)

The output voltage is reflected by the voltage on transformer's auxiliary winding. Both FB pin and VCC pin of IC integrate over voltage protection function. When there is a rapid line and load transient, the output voltage may exceed the regulated value. If V_{CC} exceeds V_{CC_OVP} or V_{FB} exceeds V_{FB_CV} , the over voltage protection will be triggered, switch will be turned off and V_{CC} will be discharged. Once V_{CC} is below V_{OPR_MIN} , the IC will shut down and be powered on again by BUS voltage through start up resistor.

Thus, output over voltage depends on the minimum voltage between both OVP protections' limitation. It can be gotten by below formula.

$$V_{OVP} = \text{Min} \left(\frac{N_S}{N_{AUX}} \cdot V_{CC_OVP}, \frac{N_S}{N_{AUX}} \cdot \frac{R5 + R6}{R6} \cdot V_{FB_CV} \right) \quad \text{----- (2)}$$

Where V_{OVP} is the output over voltage setting; R5 and R6 that is shown as Figure 1, it is the resistor divider from auxiliary winding; N_{AUX} is the turns of auxiliary winding; N_S is turns of the secondary winding. V_{CC_OVP} is OVP Voltage of V_{CC} .

2. Output short protection (OSP)

When the output is shorted, the output voltage is clamped to zero. The output voltage of the auxiliary winding, which is proportional to the output winding, will drop down too. Once V_{CC} is below V_{OPR_MIN} , the IC will shut down and power on again by the BUS voltage through the start up resistor.

3. Over Current Protection (OCP)

The AL1673 has a build-in cycle by cycle over current protection of primary inductor current. When CS pin voltage reaches the voltage V_{CS_OCP} , switch will be turned off until next switch period. The maximum peak current ($I_{PEAK(MAX)}$) of the inductor can be calculated as below:

$$I_{PEAK(MAX)} = \frac{V_{CS_OCP}}{R_{CS}} \quad \text{----- (3)}$$

Where V_{CS_OCP} means primary current clamp voltage that is 1.2V.

R_{CS} is current sense resistor which is shown as Figures 1 and 2.

4. Thermal Fold-back Protection (TFP)

The AL1673 has thermal fold-back function: it adopts self-adaptive control method which can prevent the system from breaking down caused by over temperature. The overheating temperature is set at +145°C. When the temperature of the IC is higher than this point; the device will decrease the voltage reference of the CS linearly till OTP happens. By this way, the device can limit system's input power at high ambient temperature, preventing system's temperature increases further.

5. Over Temperature Protection (OTP)

The AL1673 has build-in over temperature protection (OTP) function. When the temperature goes up to +165°C, the over temperature protection will be triggered, which leads to a latch mode protection. When OTP happens, the system need to be powered off and on again to restart.

Output Constant-current Control

According to the definition of mean output current, the mean output current can be obtained as below.

$$I_{O_MEAN} = \frac{1}{\pi} \cdot \int_0^{\pi} \frac{1}{2} \cdot I_{SP} \cdot \frac{t_{ONS}}{t_{SW}} dt \quad \text{----- (4)}$$

Where I_{O_MEAN} is the mean output current; I_{SP} is secondary peak current of transformer; t_{ONS} is discharge time of secondary side of transformer; t_{SW} is the switch period.

According to the principle of AL1673 close loop control, the voltage of R_{CS} will be sampled when switch is turned off and the value will be held until discharge time t_{ONS} is over. It can be described by following formula:

Functional Description and Application Information (Cont.)

$$V_{REF} = \frac{1}{\pi} \cdot \int_0^{\pi} I_P \cdot R_{CS} \cdot \frac{t_{ONS}}{t_{SW}} dt \tag{5}$$

Where I_P is primary peak current of transformer; R_{CS} is current sense resistor which is shown as Figures 1 and 2. t_{ONS} is discharge time of secondary side of transformer; t_{SW} is the switch period. V_{REF} is internal reference voltage that is equal to 0.3V. The peak current at secondary side has following relationship with primary side peak current, if the effect of the leakage inductor is neglected.

$$I_{SP} = N_{PS} \cdot I_P \tag{6}$$

Where N_{PS} is the turns ratio of Flyback transformer ($N_{PS}=1$ for Buck-boost); I_P is the primary peak current of the transformer.

According to these above formulas, the mean output current can be induced finally by below expressions.

$$I_{O_MEAN} = \frac{N_{PS} \cdot V_{REF}}{2 \cdot R_{CS}} \tag{7}$$

Where I_{O_MEAN} is the mean output current; R_{CS} is current sense resistor which is shown as Figures 1 and 2; V_{REF} is internal reference voltage that is equal to 0.3V; N_{PS} is the turns ratio of Flyback transformer ($N_{PS}=1$ for Buck-boost); Therefore, the constant output current control can be realized with appropriate parameter design.

PF and THD Compensation Circuit

For normal application, AL1673 can provide high PF and low THD. But there is a phase difference between input current and input voltage especially at high input voltage, thus PF and THD may not be the best situation. The below circuit can optimize this situation by reducing the phase difference. V_{BUS} is connected to the voltage point after rectifier. In normal application resistor R_{N1} is usually a several hundred kΩ resistor, R_{N2} is a hundred Ω resistor, C_{N1} is a several μF capacitor. PF and THD can be improved by debugging these components.

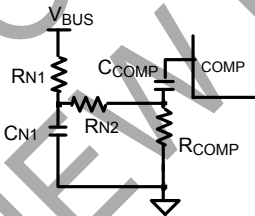

Figure 3. PF and THD Optimization Circuit

Dimming Mode

The AL1673 can support two dimming modes: analog dimming and PWM dimming.

1. Analog Dimming Mode

In analog dimming mode, the dimming signal is added to APWM pin directly to realize dimming function. The setting circuit is shown as Figure 4. A capacitance of hundreds nF is recommended for C_{APWM} . When V_{APWM} is higher than 2.4V, the driver will output 100% of rated current; when the voltage V_{APWM} is in the range from 0.3 to 2.4V, the output current will change linearly with the voltage V_{APWM} . When V_{APWM} is lower than 0.3V, switch will be turned off and the output current drops to zero. The dimming curve is shown as Figure 5 and the dimming range is from 12% to 100%.

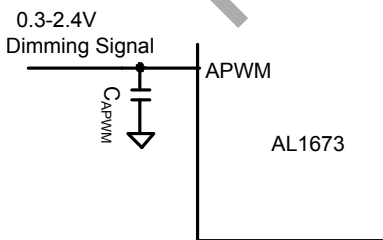

Figure 4. Analog Dimming Setting Circuit

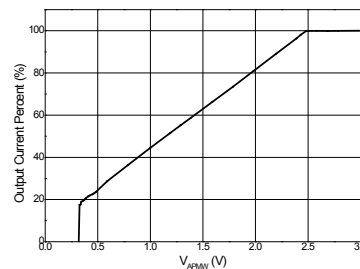

Figure 5. Analog Dimming Curve

Functional Description and Application Information (Cont.)

2. PWM Dimming Mode

In PWM dimming mode, dimming signal will be added to APWM pin. The setting circuit is shown as Figure 6. The output current is chopped by the dimming signal directly. The logic high level of the dimming signal need to be higher 2.4V while the logic low level is lower than 0.3V. Switch is turned off at logic low level. The dimming curve is shown as Figure 7. The dimming range can be 100 to 1% with 1kHz frequency of PWM signal.

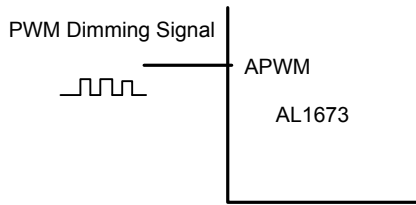

Figure 6. PWM Dimming Setting Circuit

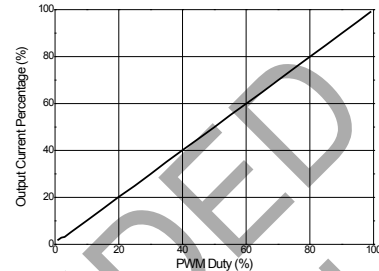

Figure 7. PWM Dimming Curve (PWM Frequency is 1 KHz)

Operation Parameters Design

Setting the Current Sense Resistor R_{CS}

The current sense resistance can be calculated as following:

$$R_{CS} = \frac{N_{PS} \cdot V_{REF}}{2 \cdot I_{O_MEAN}} \quad \text{----- (8)}$$

Where I_{O_MEAN} is the mean output current; R_{CS} is current sense resistor which is shown as Figures 1 and 2;

V_{REF} is internal reference voltage that is equal to 0.3V; N_{PS} is the turns ratio of Flyback transformer (N_{PS}=1 for Buck-boost).

Setting Transformer Selection (T1)

N_{PS} is limited by the electrical stress of the switch MOSFET, can be calculated by below formula.

$$N_{PS} \leq \frac{V_{MOS_ (BR)DS} \cdot 90\% - \sqrt{2} \cdot V_{IN_MAX} - \Delta V_S}{V_O + V_{D_F}} \quad \text{----- (9)}$$

Where V_{MOS_(BR)DS} is the breakdown voltage of the switch MOSFET. V_{IN_MAX} is the max rated input voltage. ΔV_S is the overshoot voltage clamped by RCD snobbier during OFF time. V_O is the output voltage. V_{D_F} is the forward voltage of secondary diode. N_{PS} is the turns ratio of Flyback transformer (N_{PS}=1 for Buck-boost);

For boundary conduction mode and constant on time method, the peak current of primary inductance can be calculated as below.

$$I_P = \frac{2 \cdot \pi \cdot I_{O_MEAN}}{N_{PS} \cdot \int_0^{\pi} \sin(\theta) \cdot \frac{\sqrt{2} \cdot V_{IN_RMS} \cdot \sin(\theta)}{\sqrt{2} \cdot V_{IN_RMS} \cdot \sin(\theta) + N_{PS} \cdot V_O} d\theta} \quad \text{----- (10)}$$

Where V_{IN_RMS} is the rate input voltage; I_P is the primary inductance current. N_{PS} is the turns ratio of Flyback transformer (N_{PS}=1 for Buck-boost); I_{O_MEAN} is the mean output current; V_O is the output voltage.

The switching frequency is not constant for AL1673 due to boundary conduction mode. To set the minimum switching frequency f_{MIN} at the crest of the minimum AC input, primary inductance can be obtained by below formula.

$$L_P = \frac{\sqrt{2} \cdot V_{IN_RMS} \cdot N_{PS} \cdot V_O}{I_P \cdot (\sqrt{2} V_{IN_RMS} + N_{PS} V_O) \cdot f_{MIN}} \quad \text{----- (11)}$$

Functional Description and Application Information (Cont.)

Where V_{IN_RMS} is the minimum input AC voltage; I_P is the primary inductance current. N_{PS} is the turns ratio of Flyback transformer ($N_{PS}=1$ for Buck-boost);

I_{O_MEAN} is the mean output current; V_O is the output voltage; f_{MIN} is the minimum switching frequency at the crest of the minimum input AC voltage.

According to the Faraday's Law, the winding number of the inductance can be calculated by:

$$N_P = \frac{L_P \cdot I_P}{A_e \cdot B_m} \quad \text{----- (12)}$$

$$N_S = \frac{N_P}{N_{PS}} \quad \text{----- (13)}$$

Where,

A_e is the core effective area.

B_m is the maximum magnetic flux density.

NOT RECOMMENDED
FOR NEW DESIGN

Ordering Information

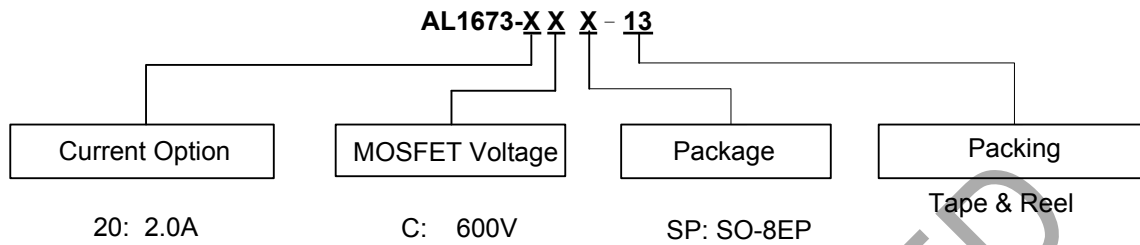

Part Number	Package Code	Package	13" Tape and Reel	
			Quantity	Part Number Suffix
AL1673-20CSP-13	SP	SO-8EP	2500/Tape & Reel	-13

Marking Information

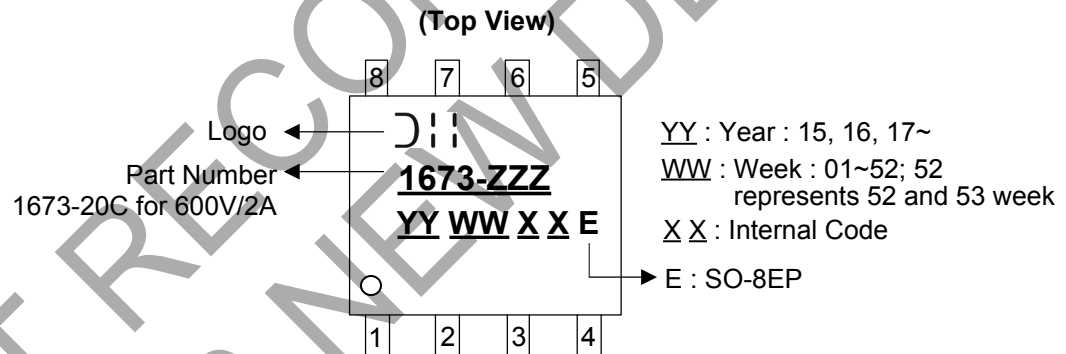

Package Outline Dimensions (All dimensions in mm.)

(1) Package Type: SO-8EP

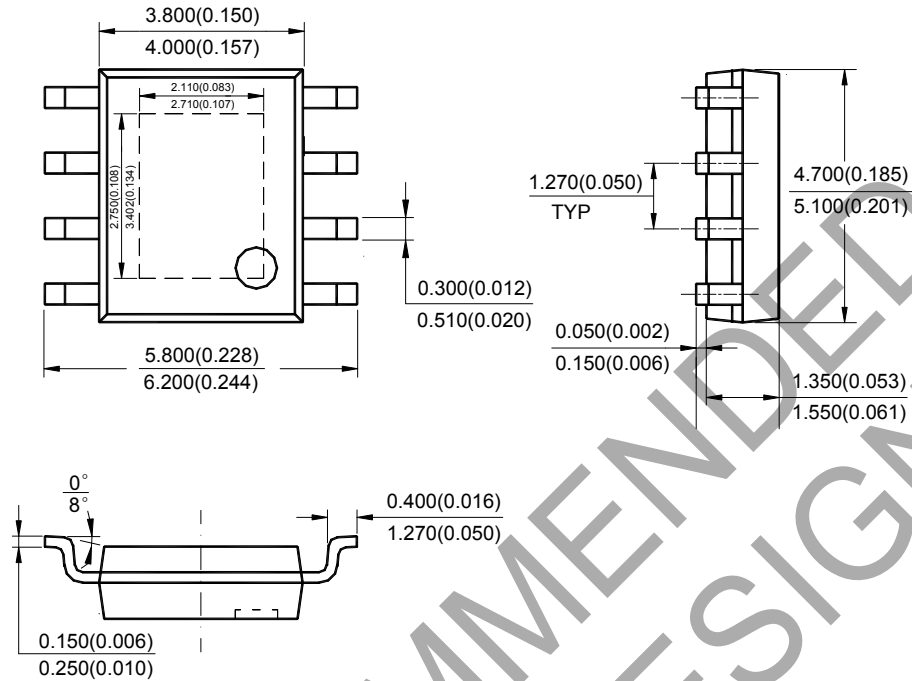

Note: Eject hole, oriented hole and mold mark is optional.

NOT RECOMMENDED FOR NEW DESIGN

Suggested Pad Layout

(1) Package Type: SO-8EP

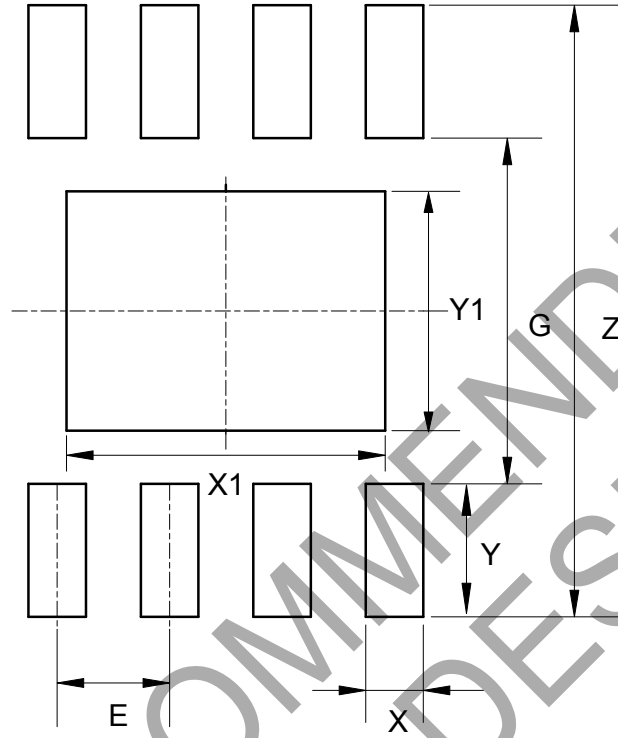

Dimensions	Z (mm)/(inch)	G (mm)/(inch)	X (mm)/(inch)	Y (mm)/(inch)	X1 (mm)/(inch)	Y1 (mm)/(inch)	E (mm)/(inch)
Value	6.900/0.272	3.900/0.154	0.650/0.026	1.500/0.059	3.600/0.142	2.700/0.106	1.270/0.050

NOT RECOMMENDED FOR NEW DESIGN

IMPORTANT NOTICE

1. DIODES INCORPORATED AND ITS SUBSIDIARIES (“DIODES”) MAKE NO WARRANTY OF ANY KIND, EXPRESS OR IMPLIED, WITH REGARDS TO ANY INFORMATION CONTAINED IN THIS DOCUMENT, INCLUDING, BUT NOT LIMITED TO, THE IMPLIED WARRANTIES OF MERCHANTABILITY, FITNESS FOR A PARTICULAR PURPOSE OR NON-INFRINGEMENT OF THIRD PARTY INTELLECTUAL PROPERTY RIGHTS (AND THEIR EQUIVALENTS UNDER THE LAWS OF ANY JURISDICTION).
2. The Information contained herein is for informational purpose only and is provided only to illustrate the operation of Diodes products described herein and application examples. Diodes does not assume any liability arising out of the application or use of this document or any product described herein. This document is intended for skilled and technically trained engineering customers and users who design with Diodes products. Diodes products may be used to facilitate safety-related applications; however, in all instances customers and users are responsible for (a) selecting the appropriate Diodes products for their applications, (b) evaluating the suitability of the Diodes products for their intended applications, (c) ensuring their applications, which incorporate Diodes products, comply the applicable legal and regulatory requirements as well as safety and functional-safety related standards, and (d) ensuring they design with appropriate safeguards (including testing, validation, quality control techniques, redundancy, malfunction prevention, and appropriate treatment for aging degradation) to minimize the risks associated with their applications.
3. Diodes assumes no liability for any application-related information, support, assistance or feedback that may be provided by Diodes from time to time. Any customer or user of this document or products described herein will assume all risks and liabilities associated with such use, and will hold Diodes and all companies whose products are represented herein or on Diodes’ websites, harmless against all damages and liabilities.
4. Products described herein may be covered by one or more United States, international or foreign patents and pending patent applications. Product names and markings noted herein may also be covered by one or more United States, international or foreign trademarks and trademark applications. Diodes does not convey any license under any of its intellectual property rights or the rights of any third parties (including third parties whose products and services may be described in this document or on Diodes’ website) under this document.
5. Diodes products are provided subject to Diodes’ Standard Terms and Conditions of Sale (<https://www.diodes.com/about/company/terms-and-conditions/terms-and-conditions-of-sales/>) or other applicable terms. This document does not alter or expand the applicable warranties provided by Diodes. Diodes does not warrant or accept any liability whatsoever in respect of any products purchased through unauthorized sales channel.
6. Diodes products and technology may not be used for or incorporated into any products or systems whose manufacture, use or sale is prohibited under any applicable laws and regulations. Should customers or users use Diodes products in contravention of any applicable laws or regulations, or for any unintended or unauthorized application, customers and users will (a) be solely responsible for any damages, losses or penalties arising in connection therewith or as a result thereof, and (b) indemnify and hold Diodes and its representatives and agents harmless against any and all claims, damages, expenses, and attorney fees arising out of, directly or indirectly, any claim relating to any noncompliance with the applicable laws and regulations, as well as any unintended or unauthorized application.
7. While efforts have been made to ensure the information contained in this document is accurate, complete and current, it may contain technical inaccuracies, omissions and typographical errors. Diodes does not warrant that information contained in this document is error-free and Diodes is under no obligation to update or otherwise correct this information. Notwithstanding the foregoing, Diodes reserves the right to make modifications, enhancements, improvements, corrections or other changes without further notice to this document and any product described herein. This document is written in English but may be translated into multiple languages for reference. Only the English version of this document is the final and determinative format released by Diodes.
8. Any unauthorized copying, modification, distribution, transmission, display or other use of this document (or any portion hereof) is prohibited. Diodes assumes no responsibility for any losses incurred by the customers or users or any third parties arising from any such unauthorized use.

Copyright © 2021 Diodes Incorporated

www.diodes.com

Looking for pricing, stock, or lifecycle information?

Click below to explore more details on WIN SOURCE:

 [View AL1673-20CSP-13 on WIN SOURCE](#)

 [Diodes Incorporated](#) Information

Optimize Your Supply Chain with WIN SOURCE Solutions

-  Global Sourcing Solution
-  Obsolete Management
-  Cost Control Management
-  Shortage Management
-  Alternative Solution
-  Excess Inventory Management