



**THE DATASHEET OF
AH49FDNTR-G1**



Description

The AH49F is a small, versatile linear Hall-effect device that is operated by the magnetic field from a permanent magnet or an electromagnet. The output voltage is set by the supply voltage and varies in proportion to the strength of the magnetic field.

The integrated circuitry features low noise output, which makes it unnecessary to use external filtering components. It also includes precision resistors to provide increased temperature stability and accuracy. The operating temperature range of these linear Hall sensors is -40°C to +105°C, appropriate for commercial, consumer, and industrial environments.

The AH49F is available in standard TO92S (Type A), SC59 and U-DFN2020-6 (Type C) packages.

Features

- Power Consumption of 3.0mA at $V_{CC} = 5V$ for Energy Efficiency
- Single Current Sourcing Output
- Linear Voltage Output for Circuit Design Flexibility
- Low Noise Output Virtually Eliminates the Need for Filtering
- A Stable and Accurate Output
- Temperature Range: -40°C to +105°C
- Responds to Either Positive or Negative Gauss
- The Maximum Instantaneous Supply Voltage Up to 50V
- High ESD Rating: 6000V (Human Body Model)
600V (Machine Model)
- Small Low Profile U-DFN2020-6 (Type C) and Industry Standard SC59 and TO92S (Type A) Packages
- **Totally Lead-free & Fully RoHS Compliant (Notes 1 & 2)**
- **Halogen and Antimony Free. "Green" Device (Note 3)**

- Notes:
1. No purposely added lead. Fully EU Directive 2002/95/EC (RoHS), 2011/65/EU (RoHS 2) & 2015/863/EU (RoHS 3) compliant.
 2. See <https://www.diodes.com/quality/lead-free/> for more information about Diodes Incorporated's definitions of Halogen- and Antimony-free, "Green" and Lead-free.
 3. Halogen- and Antimony-free "Green" products are defined as those which contain <900ppm bromine, <900ppm chlorine (<1500ppm total Br + Cl) and <1000ppm antimony compounds.

Pin Assignments

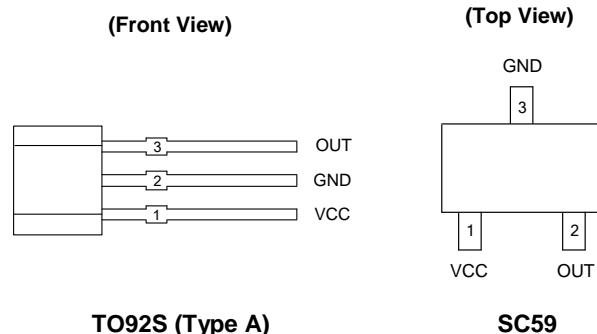

(Top View)

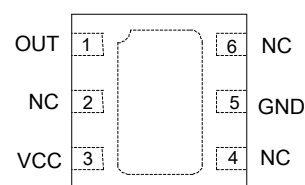

U-DFN2020-6 (Type C)

Applications

- Position Sensing
- Liquid Level Sensing
- Weight Sensing
- Ferrous Metal Detector
- Vibration Sensing
- Rotary Encoder
- Magnetic Code Reading
- Motor Control
- Current Sensing

Pin Descriptions

Package Type: TO92S (Type A)

Pin Number	Pin Name	Description
1	VCC	Power supply pin
2	GND	Ground pin
3	OUT	Output pin

Package Type: SC59

Pin Number	Pin Name	Description
1	VCC	Power supply pin
2	OUT	Output pin
3	GND	Ground pin

Package Type: U-DFN2020-6 (Type C)

Pin Number	Pin Name	Description
1	OUT	Output pin
2	NC	No connection (Note 4)
3	VCC	Power supply pin
4	NC	No connection (Note 4)
5	GND	Ground pin
6	NC	No connection (Note 4)
Pad	Pad	Center exposed pad is internally connected to GND. It can be connected to GND or left open circuit on the PCB. (Note 5)

Notes: 4. NC is "No Connection" pin and is not connected internally. This pin can be left open or tied to ground.
 5. PAD is the bottom side exposed pad.

Functional Block Diagram

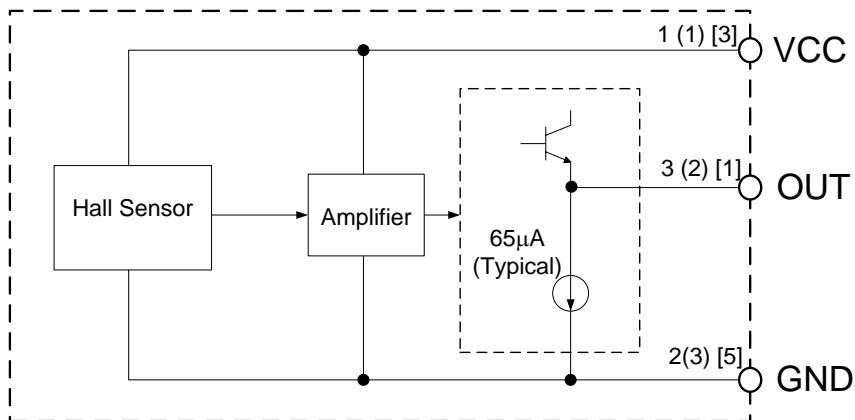

A(B)[C]
 A for TO92S (Type A)
 B for SC59
 C for U-DFN2020-6 (Type C)

Absolute Maximum Ratings (Note 6)

Symbol	Parameter	Rating		Unit
V _{CC}	Supply Voltage	10		V
V _{CC_INST}	Instantaneous Supply Voltage	50		V
P _D	Power Dissipation	TO92S (Type A)	400	mW
		SC59	230	
		U-DFN2020-6 (Type C)	230	
T _A	Ambient Temperature	-40 to +125		°C
T _{STG}	Storage Temperature	-50 to +150		°C
—	ESD (Human Body Model)	6000		V
—	ESD (Machine Model)	600		V

Notes: 6. Stresses greater than those listed under *Absolute Maximum Ratings* can cause permanent damage to the device. These are stress ratings only, and functional operation of the device at these or any other conditions beyond those indicated under *Recommended Operating Conditions* is not implied. Exposure to *Absolute Maximum Ratings* for extended periods can affect device reliability.

Recommended Operating Conditions (@T_A = +25°C)

Symbol	Parameter	Min	Max	Unit
V _{CC}	Supply Voltage	3	8	V
T _{OP}	Operating Temperature	-40	+105	°C

Electrical Characteristics (@V_{CC} = 5V, T_A = +25°C, unless otherwise specified.)

Symbol	Parameters	Conditions	Min	Typ	Max	Unit
I _{CC}	Supply Current	—	2	3	4	mA
V _{NULL}	Quiescent Output Voltage	B = 0 (Gauss)	2.25	2.5	2.75	V
V _{SEN}	Output Voltage Sensitivity	B = 0 to ±600 (Gauss)	1.7	2.1	2.5	mV/Gauss
V _{OUT_S}	Output Voltage Span	—	1.0 to (V _{CC} - 1.0)	0.8 to (V _{CC} - 0.8)	—	V
R _{OUT}	Output Resistor	—	—	60	120	Ω
B	Linear Magnetic Range	—	±500	±800	—	Gauss
—	Linearity of Span	—	—	0.7	—	%
—	Output Noise	Bandwidth=10Hz to 10kHz	—	90	—	μV

Transferring Characteristics (@V_{CC} = 5V)

When there is no external magnetic field (B=0Gauss), the quiescent output voltage is one-half the supply voltage in general.

For TO92S (Type A) and U-DFN2020-6 (Type C) packages, if a South magnetic pole approaches the part marking surface (the side with part marking ID) of the Hall effect sensor, the circuit will drive the output voltage higher. In contrary, a North magnetic pole will drive the output voltage lower. The variations of voltage level up or down from the quiescent output voltage (the null voltage) are symmetrical and proportional to the magnetic flux density. In the SC59, the die is placed underneath the lead frame and therefore when a magnet pole approaches the SC59 part marking surface, the direction of the magnetic field in to the die is reversed compared to TO92S (Type A). This results in a reverse response to the magnetic flux density in SC59 package compared with TO92S (Type A) and U-DFN2020-6 (Type C) packages. (i.e. if the reverse magnetic pole approaches the part marking surface of SC59, the output is the same as TO92S (Type A) package.) The largest magnetic sensitivity is obtained with a supply voltage of 8V, but at the cost of increased supply current and a slight loss of output symmetry. So, it is not recommended to work in such condition unless the output voltage magnitude is a main issue. The output signal can be capacitively coupled to a next-level amplifier for further amplifying if the changing frequency of the magnetic field is high.

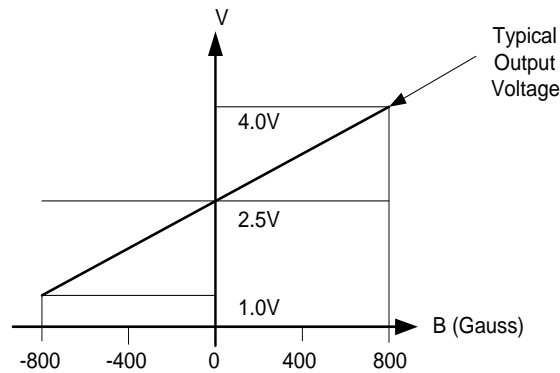

Transfer Characteristic

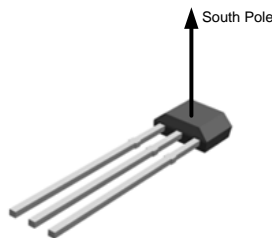

Magnetic Characteristic For TO92S (Type A)

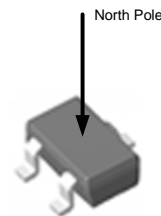

Magnetic Characteristic For SC59

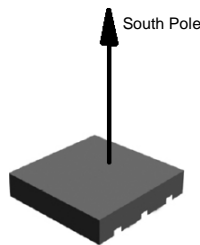

Magnetic Characteristic For U-DFN2020-6 (Type C)

Performance Characteristics

Supply Current vs. Supply Voltage

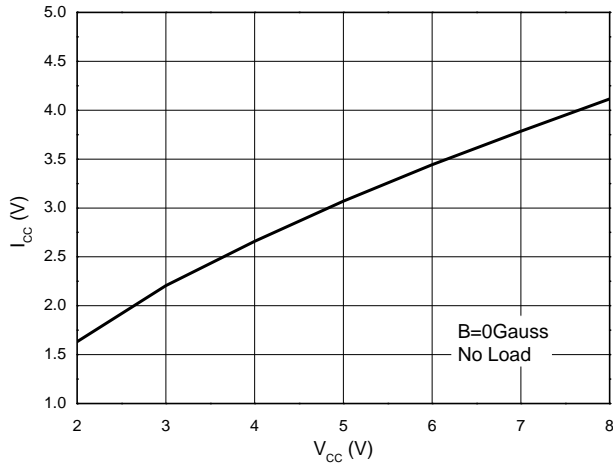

Output Voltage vs. Magnetic Field

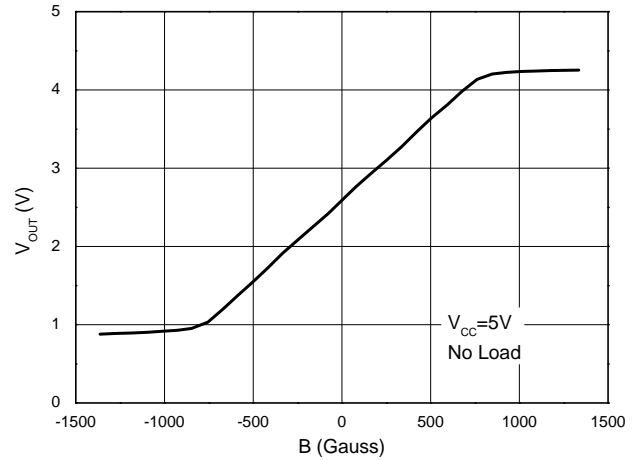

Output Voltage vs. Supply Voltage

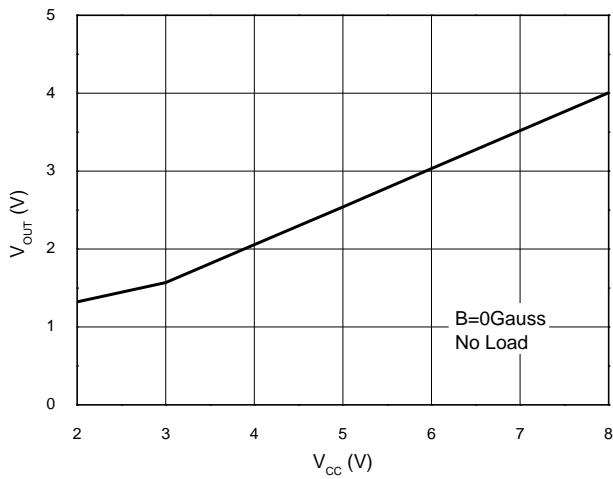

Output Voltage vs. Ambient Temperature

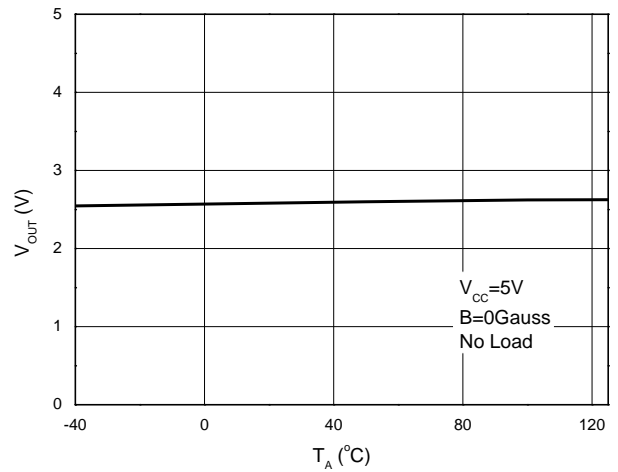

Power Dissipation vs. Ambient Temperature

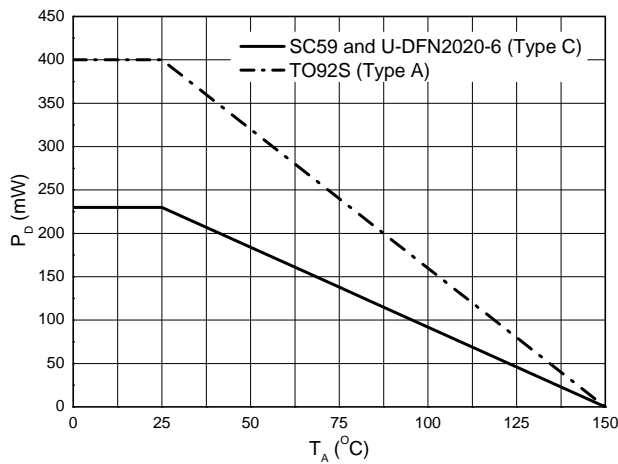

Ordering Information

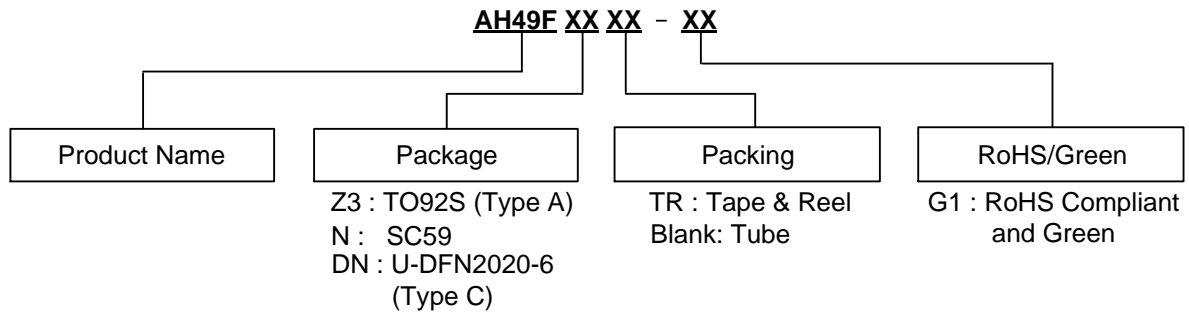

Package	Temperature Range	Part Number	Marking ID	Packing
TO92S (Type A)	-40°C to +105°C	AH49FZ3-G1	49FG	1000/Bulk
SC59		AH49FNTR-G1	GT6	3000/Tape & Reel
U-DFN2020-6 (Type C)		AH49FDNTR-G1	CN	3000/Tape & Reel

Marking Information

(1) Package Type: TO92S (Type A)

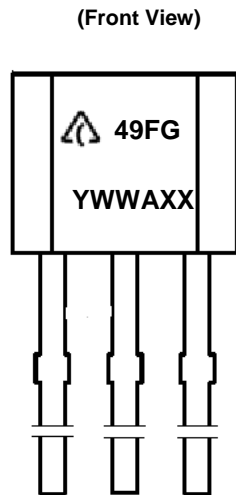

First Line: Logo and Identification Code
 Second Line: Date Code
 Y: Year 0 to 9
 WW: Week 00 to 52 (Work Week of Molding)
 A: Assembly House Code
 XX: 7th and 8th Digits: Batch No.

Part Number	Package	Identification Code
AH49F	TO92S (Type A)	49FG

Marking Information (continued)

(2) Package Type: SC59

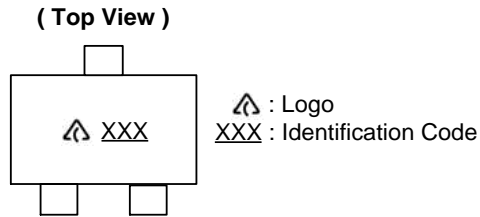

Part Number	Package	Identification Code
AH49F	SC59	GT6

(3) Package Type: U-DFN2020-6 (Type C)

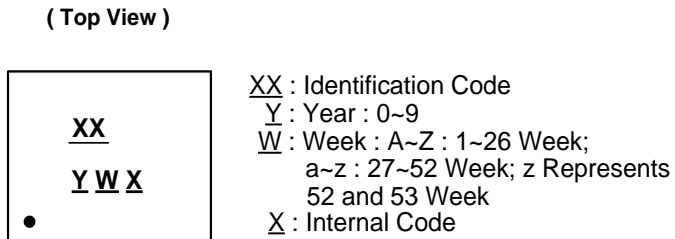

Part Number	Package	Identification Code
AH49F	U-DFN2020-6 (Type C)	CN

Package Outline Dimensions

Please see <http://www.diodes.com/package-outlines.html> for the latest version.

(1) Package Type: T092S (Type A)

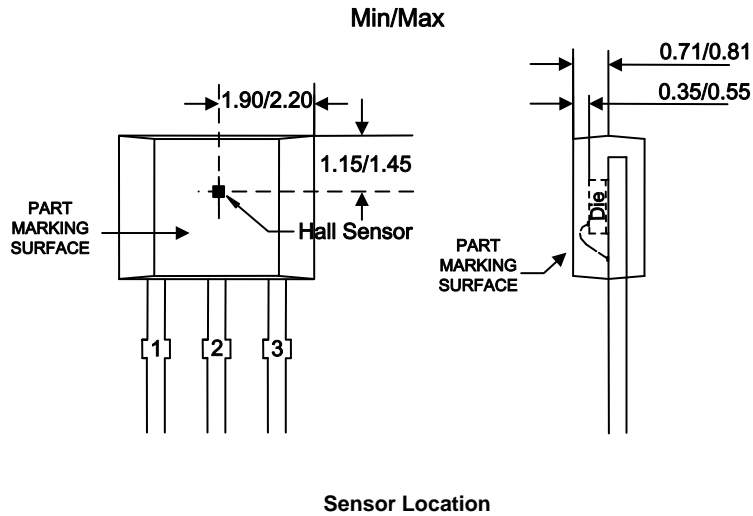
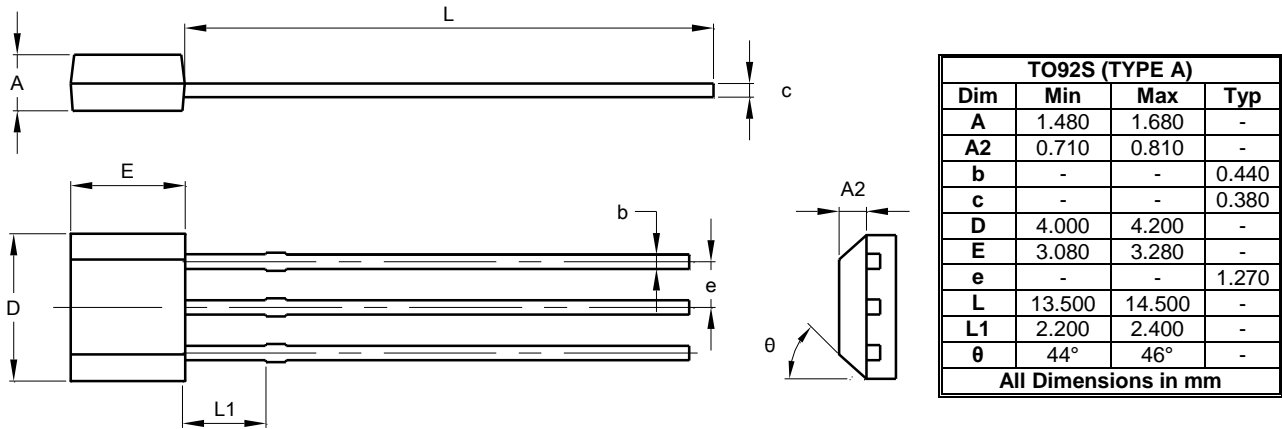

Package Outline Dimensions (continued)

Please see <http://www.diodes.com/package-outlines.html> for the latest version.

(2) Package Type: SC59

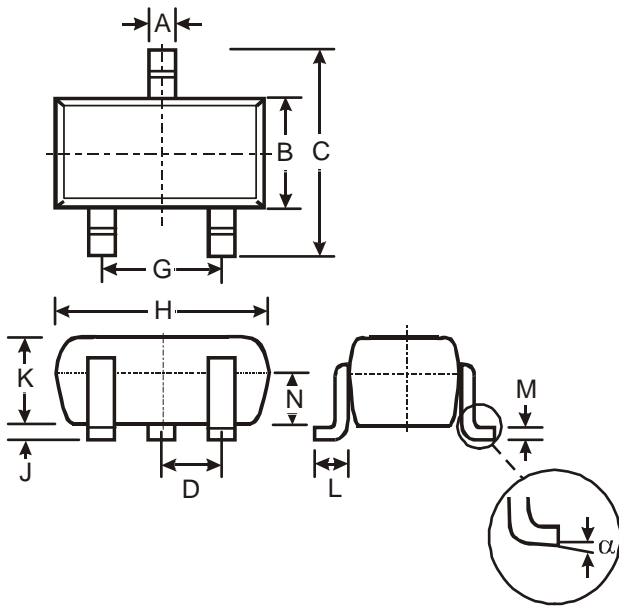

SC59			
Dim	Min	Max	Typ
A	0.35	0.50	0.38
B	1.50	1.70	1.60
C	2.70	3.00	2.80
D	-	-	0.95
G	-	-	1.90
H	2.90	3.10	3.00
J	0.013	0.10	0.05
K	1.00	1.30	1.10
L	0.35	0.55	0.40
M	0.10	0.20	0.15
N	0.70	0.80	0.75
α	0°	8°	-

All Dimensions in mm

Min/Max

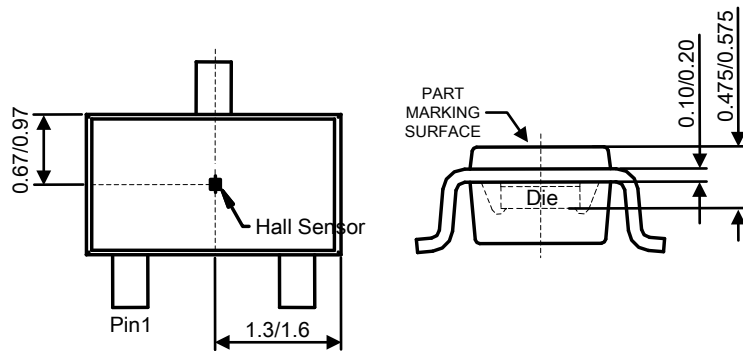

Sensor Location

Package Outline Dimensions (continued)

Please see <http://www.diodes.com/package-outlines.html> for the latest version.

(3) Package Type: U-DFN2020-6 (Type C)

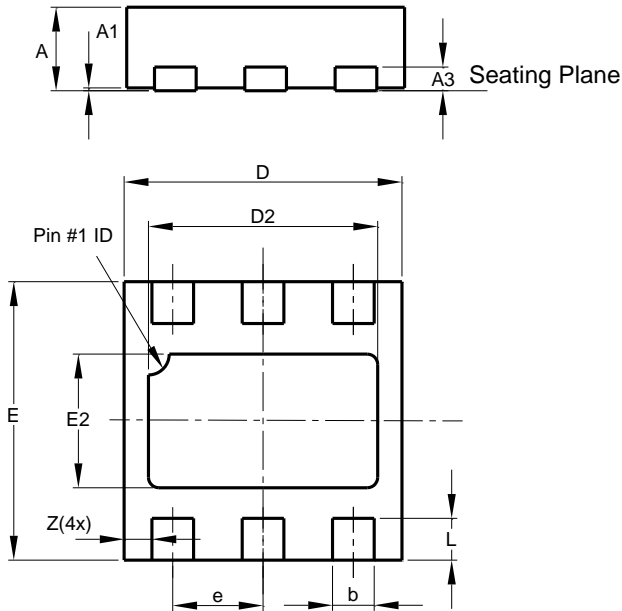

U-DFN2020-6 Type C			
Dim	Min	Max	Typ
A	0.57	0.63	0.60
A1	0.00	0.05	0.02
A3	—	—	0.15
b	0.25	0.35	0.30
D	1.95	2.075	2.00
D2	1.55	1.75	1.65
E	1.95	2.075	2.00
E2	0.86	1.06	0.96
e	—	—	0.65
L	0.25	0.35	0.30
Z	—	—	0.20
All Dimensions in mm			

Min/Max

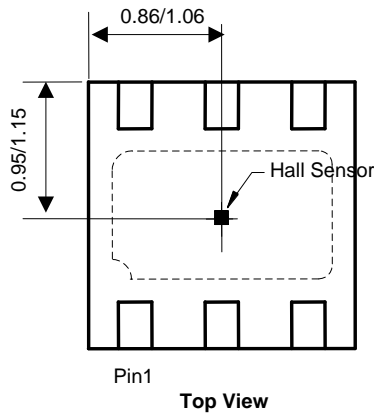

Sensor Location

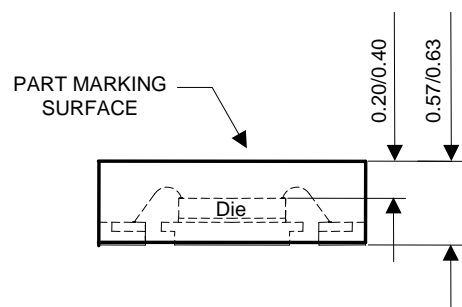

Suggested Pad Layout

Please see <http://www.diodes.com/package-outlines.html> for the latest version.

(1) Package Type: SC59

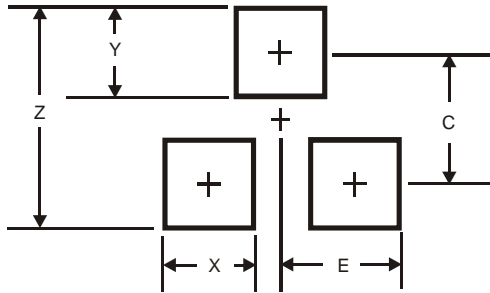

Dimensions	Value (in mm)
Z	3.4
X	0.8
Y	1.0
C	2.4
E	1.35

(2) Package Type: U-DFN2020-6 (Type C)

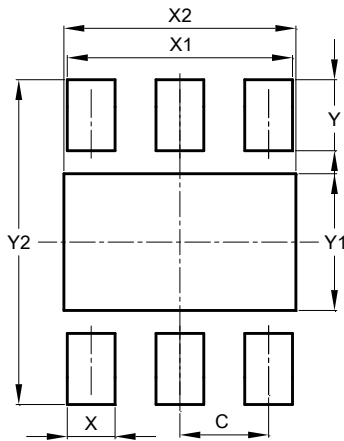

Dimensions	Value (in mm)
C	0.650
X	0.350
X1	1.650
X2	1.700
Y	0.525
Y1	1.010
Y2	2.400

IMPORTANT NOTICE

DIODES INCORPORATED MAKES NO WARRANTY OF ANY KIND, EXPRESS OR IMPLIED, WITH REGARDS TO THIS DOCUMENT, INCLUDING, BUT NOT LIMITED TO, THE IMPLIED WARRANTIES OF MERCHANTABILITY AND FITNESS FOR A PARTICULAR PURPOSE (AND THEIR EQUIVALENTS UNDER THE LAWS OF ANY JURISDICTION).

Diodes Incorporated and its subsidiaries reserve the right to make modifications, enhancements, improvements, corrections or other changes without further notice to this document and any product described herein. Diodes Incorporated does not assume any liability arising out of the application or use of this document or any product described herein; neither does Diodes Incorporated convey any license under its patent or trademark rights, nor the rights of others. Any Customer or user of this document or products described herein in such applications shall assume all risks of such use and will agree to hold Diodes Incorporated and all the companies whose products are represented on Diodes Incorporated website, harmless against all damages.

Diodes Incorporated does not warrant or accept any liability whatsoever in respect of any products purchased through unauthorized sales channel. Should Customers purchase or use Diodes Incorporated products for any unintended or unauthorized application, Customers shall indemnify and hold Diodes Incorporated and its representatives harmless against all claims, damages, expenses, and attorney fees arising out of, directly or indirectly, any claim of personal injury or death associated with such unintended or unauthorized application.

Products described herein may be covered by one or more United States, international or foreign patents pending. Product names and markings noted herein may also be covered by one or more United States, international or foreign trademarks.

This document is written in English but may be translated into multiple languages for reference. Only the English version of this document is the final and determinative format released by Diodes Incorporated.

LIFE SUPPORT

Diodes Incorporated products are specifically not authorized for use as critical components in life support devices or systems without the express written approval of the Chief Executive Officer of Diodes Incorporated. As used herein:

A. Life support devices or systems are devices or systems which:

1. are intended to implant into the body, or
2. support or sustain life and whose failure to perform when properly used in accordance with instructions for use provided in the labeling can be reasonably expected to result in significant injury to the user.

B. A critical component is any component in a life support device or system whose failure to perform can be reasonably expected to cause the failure of the life support device or to affect its safety or effectiveness.

Customers represent that they have all necessary expertise in the safety and regulatory ramifications of their life support devices or systems, and acknowledge and agree that they are solely responsible for all legal, regulatory and safety-related requirements concerning their products and any use of Diodes Incorporated products in such safety-critical, life support devices or systems, notwithstanding any devices- or systems-related information or support that may be provided by Diodes Incorporated. Further, Customers must fully indemnify Diodes Incorporated and its representatives against any damages arising out of the use of Diodes Incorporated products in such safety-critical, life support devices or systems.

Copyright © 2019, Diodes Incorporated

www.diodes.com

Looking for pricing, stock, or lifecycle information?

Click below to explore more details on WIN SOURCE:

- ⊖ [View AH49FDNTR-G1 on WIN SOURCE](#)
- ⊖ [Diodes Incorporated Information](#)

Optimize Your Supply Chain with WIN SOURCE Solutions

- ✓ Global Sourcing Solution
- ✓ Obsolete Management
- ✓ Cost Control Management
- ✓ Shortage Management
- ✓ Alternative Solution
- ✓ Excess Inventory Management