



**THE DATASHEET OF
ADS8380EVM**



ADS8380EVM

This user's guide describes the characteristics, operation, and use of the ADS8380 18-bit, 600-kHz, high-speed, serial interface analog-to-digital converter evaluation board (EVM). A complete circuit description, schematic diagram, and bill of materials are included.

The following related documents are available on the TI Web site at www.ti.com.

Data Sheets:	Literature Numbers:
ADS8380	SLAS387
REF1004C-2.5	SBVS002
SN74AHC1G125	SCLS377
THS4031	SLOS224
OPA132	SBOS054

Contents

1	EVM Overview	2
2	Analog Interface.....	2
3	Digital Interface	4
4	Power Supplies	5
5	Using the EVM	6
6	ADS8380EVM Bill Of Materials	7
8	Board Layers	9
9	Schematics	13

List of Figures

1	Input Buffer Circuit.....	3
2	Top Layer	9
3	Power Plane	10
4	Ground Plane	11
5	Bottom Layer.....	12

List of Tables

1	Analog Input Connector	2
2	Jumper Setting	4
3	Pinout for Serial Control Connector P2	5
4	Power Supply Test Points	5
5	Power Connector J2 Pinout	5
7	ADS8380EVM Bill of Materials.....	7

1 EVM Overview

1.1 Features

- Full-featured evaluation board for the ADS8380 18-bit, 600-kHz, single-channel, high-speed serial-interface analog-to-digital converter (ADC)
- Onboard signal conditioning
- Onboard reference
- Input and output digital buffer

2 Analog Interface

The ADS8380 analog-to-digital converter has both a positive and negative analog input pin. A signal for the positive input pin can be applied at connector P1, pin 2 (shown in [Table 1](#)) or applied to the center pin of SMA connector J1. The EVM ships with the negative input pin shorted to ground close to the converter using via SJP7. The negative and positive input pins have a range of -200 mV to +200 mV and -200 mV to VREF+200 mV, respectively.

Table 1. Analog Input Connector

Description	Signal Name	Connector Pin No.		Signal Name	Description
Inverting Input	-IN	P1.1	P1.2	+IN	Noninverting Input
Reserved	N/A	P1.3	P1.4	N/A	Reserved
Reserved	N/A	P1.5	P1.6	N/A	Reserved
Reserved	N/A	P1.7	P1.8	N/A	Reserved
Ground	AGND	P1.9	P1.10	N/A	Reserved
Ground	AGND	P1.11	P1.12	N/A	Reserved
Reserved	N/A	P1.13	P1.14	N/A	Reserved
Ground	AGND	P1.15	P1.16	N/A	Reserved
Ground	AGND	P1.17	P1.18	N/A	Reserved
Reserved	N/A	P1.19	P1.20	REF+	External Reference Input

2.1 Signal Conditioning

It is a recommended practice to buffer the analog input to any SAR-type converter with a high-speed, fast-settling, low-noise amplifier. The amplifier circuit shown in [Figure 1](#) is the buffer circuit used on the ADS8380EVM. This circuit consists of the THS4031, a high-speed, low-noise, low-distortion amplifier configured as an inverting gain of one. The circuit shown in [Figure 1](#) was optimized to achieve the ac specifications (i.e., SNR, THD, SFDR, etc.) listed in the ADS8380 data sheet. The 12- Ω series resistor works with the capacitor to filter the input signal, but also isolates the amplifier from the capacitive load. The 6800-pF capacitor to ground at the input of the ADC works with the series resistor to filter the input signal, behaves like a charge reservoir, and provides a short to ground for high-frequency noise and kickback currents when the device switches from hold to sample mode. This external filter capacitor also works with the amplifier to charge the internal sampling capacitor during sampling mode.

The type of input capacitors used in the signal path can make a few decibels of difference in ac performance. Polypropylene or C0G-type capacitors are recommended for the input signal path. Polypropylene capacitors cause the least distortion of the input signal and have excellent long-term stability, but are expensive and bulky. C0G ceramic capacitors cost less, come in smaller packages, and perform as well as polypropylene capacitors in many applications, but are not as stable over time and temperature. The 68-pF and 6800-pF capacitors installed on the EVM are low-cost C0G type, manufactured by TDK Corporation.

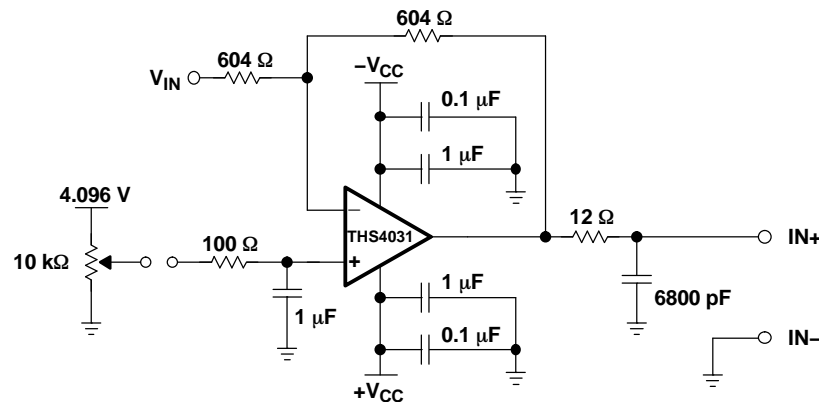

Figure 1. Input Buffer Circuit

2.2 Reference Voltage

The ADS8380EVM allows the designer to select internal, onboard, or user-supplied reference-voltage sources. The internal reference is a 4.096-V reference voltage generated by the ADS8380 on pin 9. The onboard reference can be either a REF3040 (U1) or REF1004-2.5 (U13). The EVM ships with the REF1004-2.5 installed. The reference amplifier, U3, is set for a gain of 1.6, enabling it to take a 2.5-V input and output 4.1 V for use with the converter, or as part of the dc offset voltage circuit for the input buffer (U4). The user-supplied reference voltage is applied to connector P1, pin 20 and can be routed through the reference buffer and filtered, if desired. The EVM allows a number of configurations. See [Table 1](#) for jumper settings or the full schematic in [Section 9](#) for more information. The common SOIC footprint of U13 allows users to evaluate this converter with various reference ICs.

The ADS8380EVM ships with the internal reference tied directly to the reference pin of the converter.

Table 2. Jumper Setting

Reference Designator	Description	Pins/Pads	
		1-2	2-3
SJP1	Buffer onboard reference (REF1004-2.5)	Shorted ⁽¹⁾	Open
	Buffer user-supplied reference voltage applied at P1 pin 20	Open	Shorted
SJP2	Connect external reference directly to SJP4	Shorted ⁽¹⁾	Open
	Connect buffered external reference to SJP4	Open	Shorted
SJP3	Connect U2 negative supply to ground	Shorted	Open
	Connect U2 negative supply to -VCC	Open	Shorted ⁽¹⁾
SJP4	Connect internal reference to REFIN	Shorted ⁽¹⁾	Open
	Connect external reference to REFIN	Open	Shorted
SJP5	Connect U4 negative supply to ground	Shorted	Open
	Connect U4 negative supply to -VCC	Open	Shorted ⁽¹⁾
SJP6	Connect DC offset voltage to U4	Shorted ⁽¹⁾	N/A
SJP7	Connect -IN pin to analog ground	Shorted ⁽¹⁾	N/A
W1	Connect +5VD to BVDD	Shorted ⁽¹⁾	Open
	Connect +3.3VD to BVDD	Open	Shorted
W2	Set signal straight binary/2s complement ($\overline{SB}/2C$) high	Shorted	N/A
W3	Set power down signal (PD) high	Shorted	N/A
W4	Set frame sync signal (FS) high	Shorted	N/A
W5	Set chip select signal (\overline{CS}) low	Shorted	N/A

⁽¹⁾ Factory Installed

3 Digital Interface

The ADS8380EVM is designed for easy interfacing to multiple platforms. Samtec plug and socket connectors provide a convenient dual row header/socket combination at P1 and P2 to plug into prototype boards or through ribbon cable to user system boards.

The digital input and output signals for the converter is available at connector P2 on the ADS8380EVM; see [Table 3](#) for the connector pinout.

Table 3. Pinout for Serial Control Connector P2

Description	Signal Name	Connector Pin		Signal Name	Description
Chip Select	\overline{CS}	P2.1	P2.2	SB/2C	Straight binary or 2s complement output
Serial Clock	SCLK	P2.3	P2.4	DGND	Ground
Reserved	N/A	P2.5	P2.6	N/A	Reserved
Frame Sync	FS	P2.7	P2.8	N/A	Reserved
Reserved	N/A	P2.9	P2.10	N/A	Reserved
Reserved	N/A	P2.11	P2.12	N/A	Reserved
Serial Data Out	SDO	P2.13	P2.14	N/A	Reserved
BUSY	BUSY	P2.15	P2.16	N/A	Reserved
Convert Start	\overline{CONVST}	P2.17	P2.18	DGND	Ground
Power down	PD	P2.19	P2.20	N/A	Reserved

4 Power Supplies

The EVM accepts four power supplies:

- A dual $\pm V_s$ dc supply for the dual-supply operational amplifiers. The maximum recommended voltage is ± 12 Vdc.
- A single +5-Vdc supply for the analog section of the board (A/D + Reference).
- A single +5-Vdc or +3.3-Vdc supply for the digital section of the board (A/D + buffers).

There are two ways to provide these voltages. The first way is to connect the voltages to the test points listed in [Table 4](#).

Table 4. Power Supply Test Points

Test Point	Signal	Description
TP1	+VA	Connect +12-Vdc supply for amplifier
TP2	-VA	Connect -12-Vdc supply for amplifier
TP3	+BVDD	Apply +3.3 Vdc or +5 Vdc. See ADC data sheet for full range.
TP4	+AVCC	Apply +5 Vdc

The second way is to use the power connector J2 and derive the voltages elsewhere. [Table 5](#) gives the pinout for J2. If using this connector, set W1 jumper to connect +3.3VD or +5VD from J2 to +BVDD. Shunt pins 1-2 to select +5VD, or pins 2-3 to select +3.3VD as the source for the digital buffer voltage supply (+BVDD).

Table 5. Power Connector J2 Pinout

Signal	J2 Pin		Signal
+VA(+12V)	1	2	-VA(-12 V)
+5VA	3	4	N/C
DGND	5	6	AGND
N/C	7	8	N/C
+3.3VD	9	10	+5VD

5 Using the EVM

The ADS8380EVM serves three functions:

1. As a reference design
2. As a prototype board
3. As a software test platform

5.1 Reference Design

As a reference design, the ADS8380EVM contains the essential circuitry to showcase the analog-to-digital converter. This essential circuitry includes the input amplifier, reference circuit, and buffers. The EVM analog-input circuit is optimized for a 100-kHz input signal; therefore, users may need to adjust the resistor and capacitor values to accommodate higher frequencies. In ac-type applications where signal distortion is a concern, polypropylene or C0G-type capacitors are recommended for use in the signal path.

5.2 Prototype Board

As a prototype board, the buffer circuit has resistor pads for configuring the input as either single-ended or fully differential input. The input circuit can be modified to accommodate user prototype needs, whether it be evaluating another differential amplifier or limiting noise for best performance. The analog, power, and digital connectors can be made to plug into a standard 0.1-in. breadboard or ribbon cables to interface directly to FPGAs or processors.

5.3 Software Test Platform

As a software test platform, connectors P1 and P2 plug into the serial interface connectors of the 5-6K Interface Board. The 5-6K Interface Board plugs into the TMS320C5000 and TMS320C6000 Digital Signal Processor starter kits (DSK). See the *5-6K Interface Board User's Guide* ([SLAU104](#)) for more information.

6 ADS8380EVM Bill Of Materials

The following table contains a complete bill of materials for the ADS8380EVM. The schematic diagram is also provided for reference. Contact the Product Information Center or email dataconvapps@list.ti.com for questions regarding this EVM.

Table 7. ADS8380EVM Bill of Materials

Item No.	QTY	Value	Reference Designator	Footprint	Manufacturer	Manufacturer's Part Number	Description
1	1	49.9 Ω	R1	805	Panasonic - ECG or Alternate	ERJ-6ENF49R9V	RES 49.9 Ω 1/10W 1% 0805 SMD
2	1	1.2 kΩ	R2	603	Yageo America or Alternate	9C06031A1201FKHFT	RES 1.20 kΩ 1/10 W 1% 0603 SMD
3	2	NI	R4, R5	805	Not Installed	Not Installed	
4	3	0 Ω	R6, R15, R30	603	Panasonic - ECG or Alternate	ERJ-3GEY0R00V	RES 0 Ω 1/16 W 5% 0603 SMD
5	7	10 kΩ	R7, R8, R9, R10, R11, R12, R32	603	Panasonic - ECG or Alternate	ERJ-3EKF1002V	RES 10 KΩ 1/16 W 1% 0603 SMD
6	1	10 kΩ	R13	BOURNS_32X4W	Bourns	3214W-1-103E	TRIMPOT 10 KΩ 4MM TOP ADJ SMD
7	1	768 Ω	R14	603	Panasonic - ECG or Alternate	ERJ-3EKF7680V	RES 768 Ω 1/16 W 1% 0603 SMD
8	2	0 Ω	R16, R17	805	Panasonic - ECG or Alternate	ERJ-6GEY0R00V	RES 0 Ω 1/10 W 5% 0805 SMD
9	2	604 Ω	R18, R19	805	Panasonic - ECG or Alternate	ERJ-6ENF6040V	RES 604 Ω 1/10 W 1% 0805 SMD
10	1	100 Ω	R20	805	Panasonic - ECG or Alternate	ERJ-6ENF1000V	RES 100 Ω 1/10 W 1% 0805 SMD
11	1	12 Ω	R21	805	Panasonic - ECG or Alternate	ERJ-6GEYJ120V	RES 12 Ω 1/8 W 5% 0805 SMD
12	8	100	R22, R23, R24, R25, R26, R27, R28, R29	603	Panasonic - ECG or Alternate	ERJ-3EKF1000V	RES 100 Ω 1/16 W 1% 0603 SMD
13	1	1 kΩ	R31	603	Panasonic - ECG or Alternate	ERJ-3EKF1001V	RES 1 kΩ 1/16 W 1% 0603 SMD
14	1	49.9 kΩ	R33	805	Panasonic - ECG or Alternate	ERJ-6ENF4992V	RES 49.9 kΩ 1/10 W 1% 0805 SMD
15	1	47 μF	C1	1206	TDK Corporation or Alternate	C3216X5R0J476M	CAP CER 47 μF 6.3 V X5R 20% 1206
16	5	1 μF	C2, C3, C4, C5, C31	805	TDK Corporation or Alternate	C2012X7R1E105K	CAP CER 1 μF 25 V X7R 0805 T/R
17	8	NI	C6, C7, C21, C23, C44, C45, C59, C60	603	Not Installed	Not Installed	Multilayer Ceramic
18	4	0.1 μF	C8, C9, C10, C11	805	TDK Corporation or Alternate	C2012X7R1E104K	CAP CER 0.1 μF 25 V X7R 10% 0805
19	12	0.1 μF	C12, C13, C16, C17, C18, C52, C53, C54, C55, C56, C57, C58	603	TDK Corporation or Alternate	C1608X7R1E104K	CAP CER 0.1 μF 25 V X7R 10% 0603
20	6	2.2 μF	C14, C15, C19, C20, C28, C50	603	TDK Corporation or Alternate	C1608X5R1A225MT	CAP CER 2.2 μF 6.3 V X5R 20% 0603
21	3	NI	C22, C32, R3	805	Not Installed	Not Installed	Multilayer Ceramic
22	1	10 μF	C24	3528	Kemet or Alternate	T491B106K016AS	CAPACITOR TANT 10 μF 16 V 10% SMD
23	8	0.01 μF	C25, C26, C27, C29, C30, C42, C43, C51	603	TDK Corporation or Alternate	C1608X7R1H103KT	CAP CER 10000 pF 50 V X7R 10% 0603
24	1	6800 μF	C33	805	TDK Corporation or Alternate	C2012C0G1H682J	CAP CER 6800 pF 50 V C0G 5% 0805
25	4	10 μF	C34, C35, C36, C37	1206	TDK Corporation or Alternate	C3216X5R1C106KT	CAP CER 10 μF 16 V X5R 20% 1206
26	4	10 μF	C38, C39, C40, C41	6032	Panasonic - ECG or Alternate	ECS-T1EC106R	CAP 10 μF 25 V Tantalum TE SMD
27	5	1000 pF	C46, C47, C48, C49, C62	603	TDK Corporation or Alternate	C1608C0G1H102KT	CAP CER 1000 pF 50 V C0G 0603 T/R

Table 7. ADS8380EVM Bill of Materials (continued)

Item No.	QTY	Value	Reference Designator	Footprint	Manufacturer	Manufacturer's Part Number	Description
28	1	1 μ F	C61	603	TDK Corporation or Alternate	C1608X5R1A105KT	CAP CER 1 μ F 10 V X5R 10% 0603
29	4	MMZ2012R601A	L1, L2, L3, L4	805	TDK Corporation or	MMZ2012R601A	FERRITE CHIP 600 Ω 500 mA 0805
30	1	NI	U1	3-SOT-23	Not Installed	Not Installed	REF3040 SOT23-3 CMOS Voltage Reference
31	1	OPA132	U2	8-SOP(D)	Texas Instruments	OPA132U	High-Speed FET-Input Operational Amplifier
32	8	SN74X1G125	U3, U6, U7, U8, U9, U10, U11, U12	5-SOT(DBV)	Texas Instruments	SN74AHC1G125DBVR	Single Bus Buffer Gate/Line Driver with 3-State Output
33	1	THS4031	U4	8-SOT(D)	Texas Instruments	THS4031CD	100-MHz Low-Noise High-Speed Amplifier
34	1	ADS8380	U5	28-PQFP (QFN)	Texas Instruments	ADS8380IBRHPT	18-Bit 600 kSPS Serial Analog-to-Digital Converter
35	1	REF1004-2.5	U13	8-SOP(D)	Texas Instruments	REF1004C-2.5	2.5-V Micropower Voltage Reference
36	1	SMA_PCB_MT	J1	SMA_JACK	Johnson Components Inc.	142-0701-301	Right Angle SMA Connector
37	1	Power Supply	J2	5X2X.1_SMT_Socket	Samtec	SSW-105-22-S-D-VS	0.025-In. SMT Socket - Bottom Side of PWB
38	1				Samtec	TSM-105-01-T-D-V-P	0.025-In. SMT Plug - Top Side of PWB
39	2	10X2X.1	P1, P2	10X2X.1_SMT_P LUG_& SOCKET	Samtec	SSW-110-22-S-D-VS	0.025-In. SMT Socket - Bottom Side of PWB
40	2				Samtec	TSM-110-01-T-D-V-P	0.025-In. SMT Plug - Top Side of PWB
41	1	3POS_JUMPER	W1	3pos_jump	Samtec	TSW-103-07-L-S	3-Position Jumper_0.1-In. Spacing
42	4	2POS_JUMPER	W2, W3, W4, W5	2pos_jump	Samtec	TSW-102-07-L-S	2-Position Jumper_0.1-In. Spacing
43	2	SJP2	SJP6, SJP7	SJP2	Not Installed	Not Installed	Pad 2 Position Jumper
44	5	SJP3	SJP1, SJP2, SJP3, SJP4, SJP5	SJP3	Not Installed	Not Installed	Pad 3 Position Jumper
45	10	TP_.025	TP1, TP2, TP3, TP4, TP5, TP6, TP7, TP8, TP10, TP13,	test_point2	Keystone Electronics	5000K-ND	Test Point PC Mini 0.040-In. D Red
46	4	TP_0.25	TP9, TP11, TP12, TP14	test_point2	Keystone Electronics	5001K-ND	Test Point PC Mini 0.040-In D Black

8 Board Layers

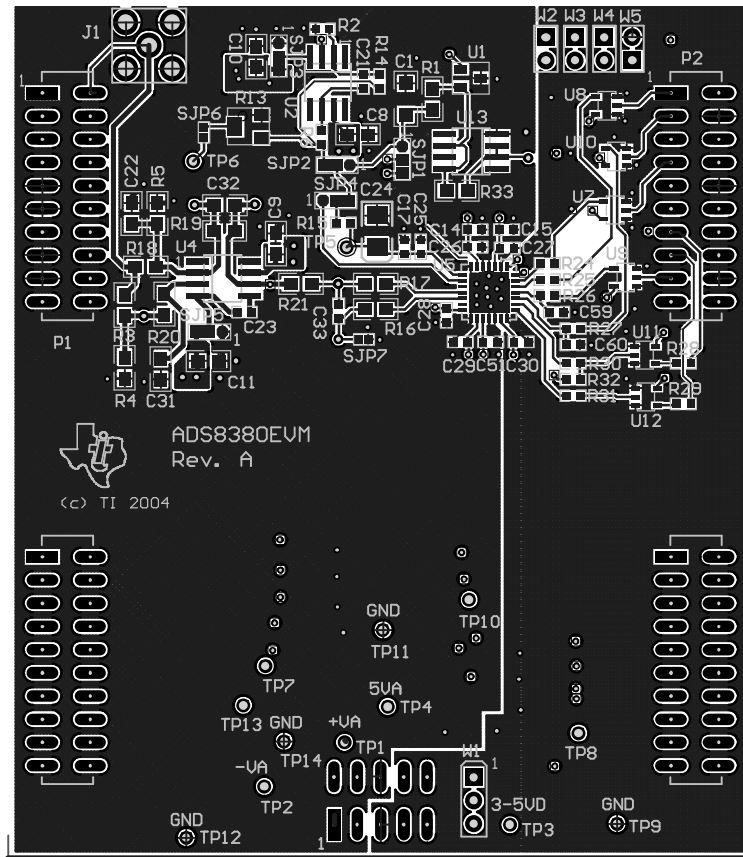

Figure 2. Top Layer

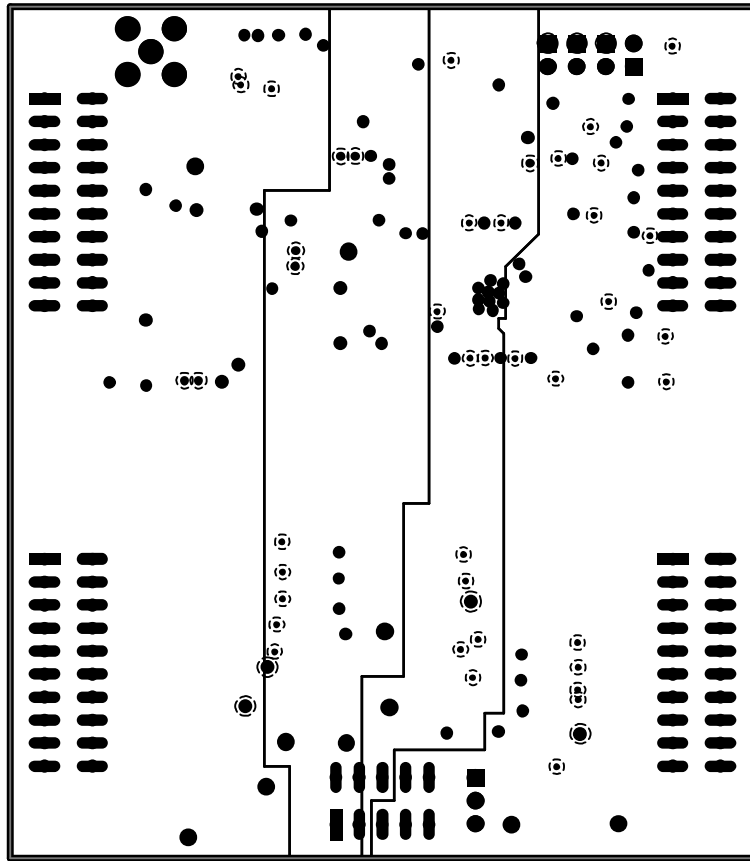

Figure 3. Power Plane

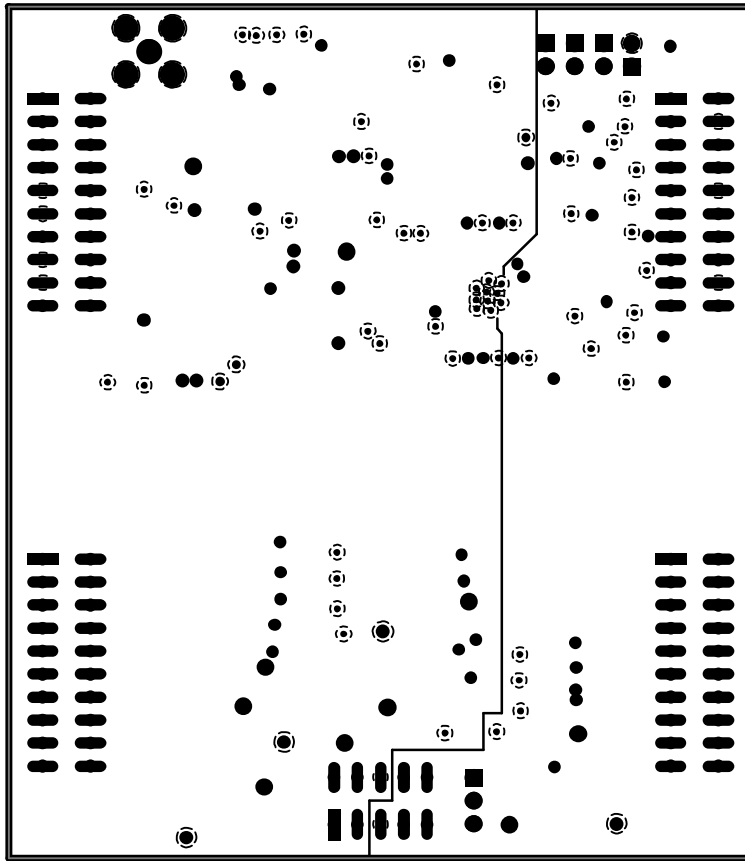

Figure 4. Ground Plane

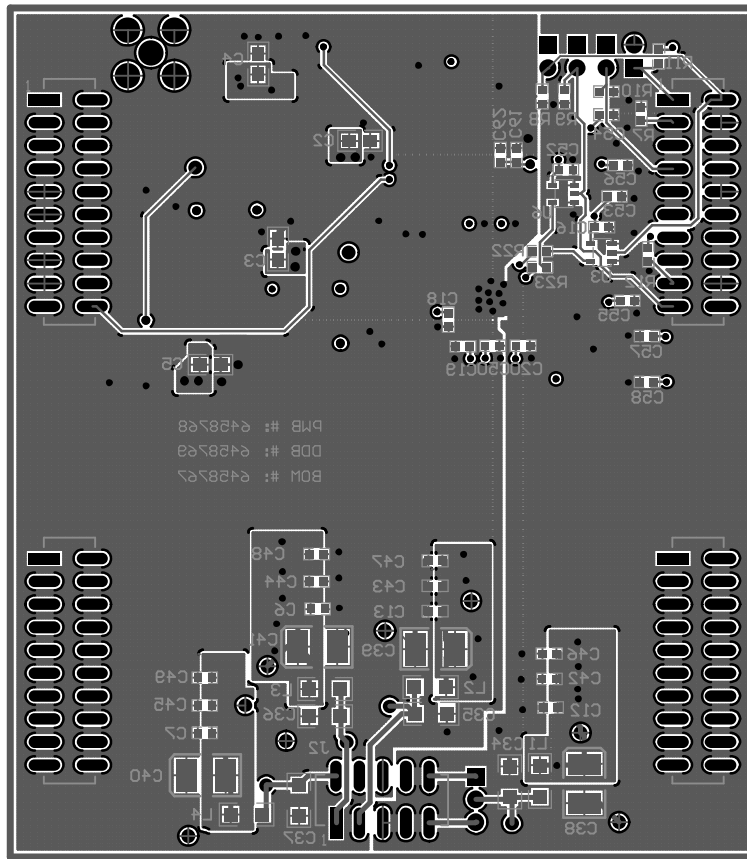
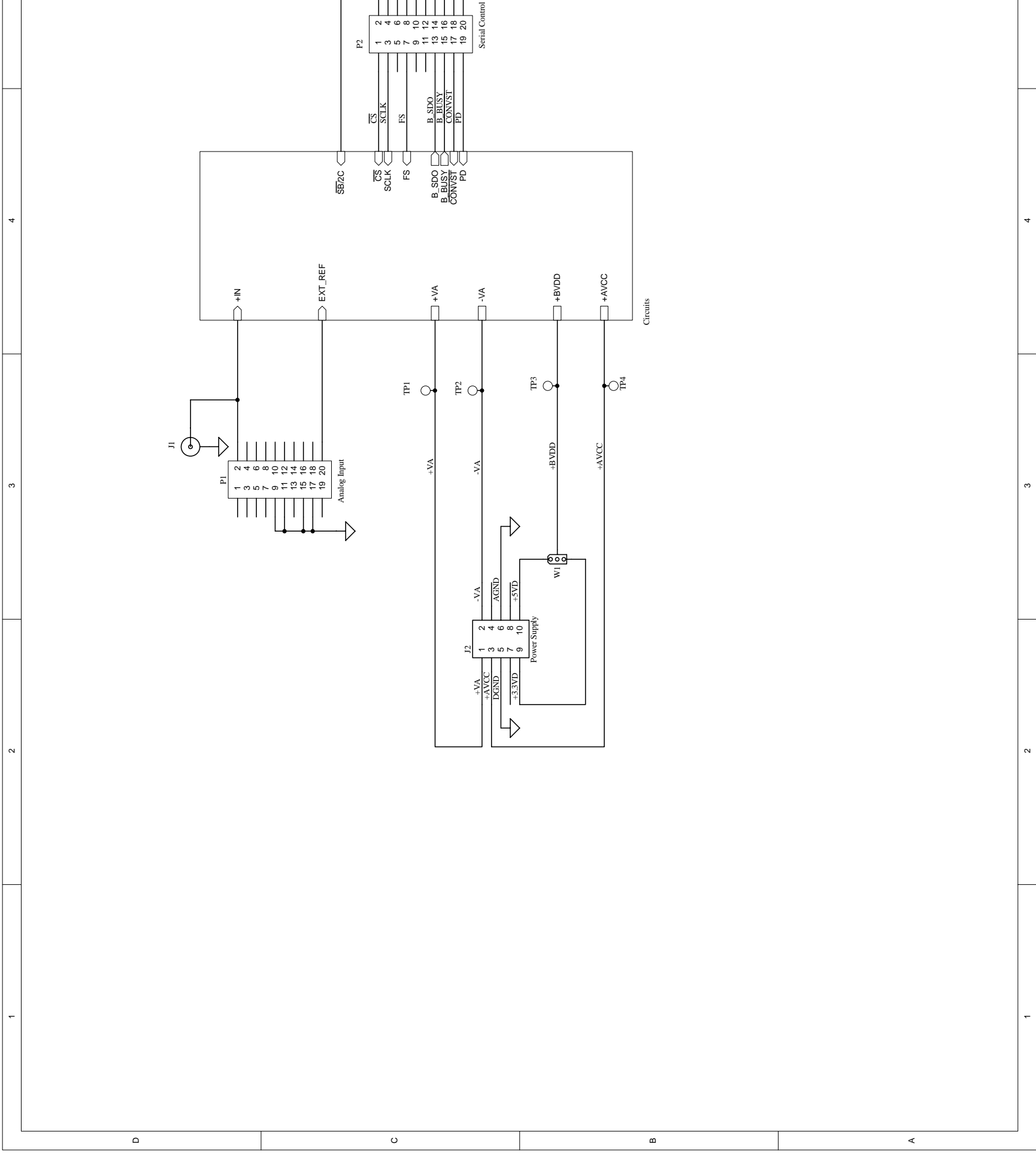
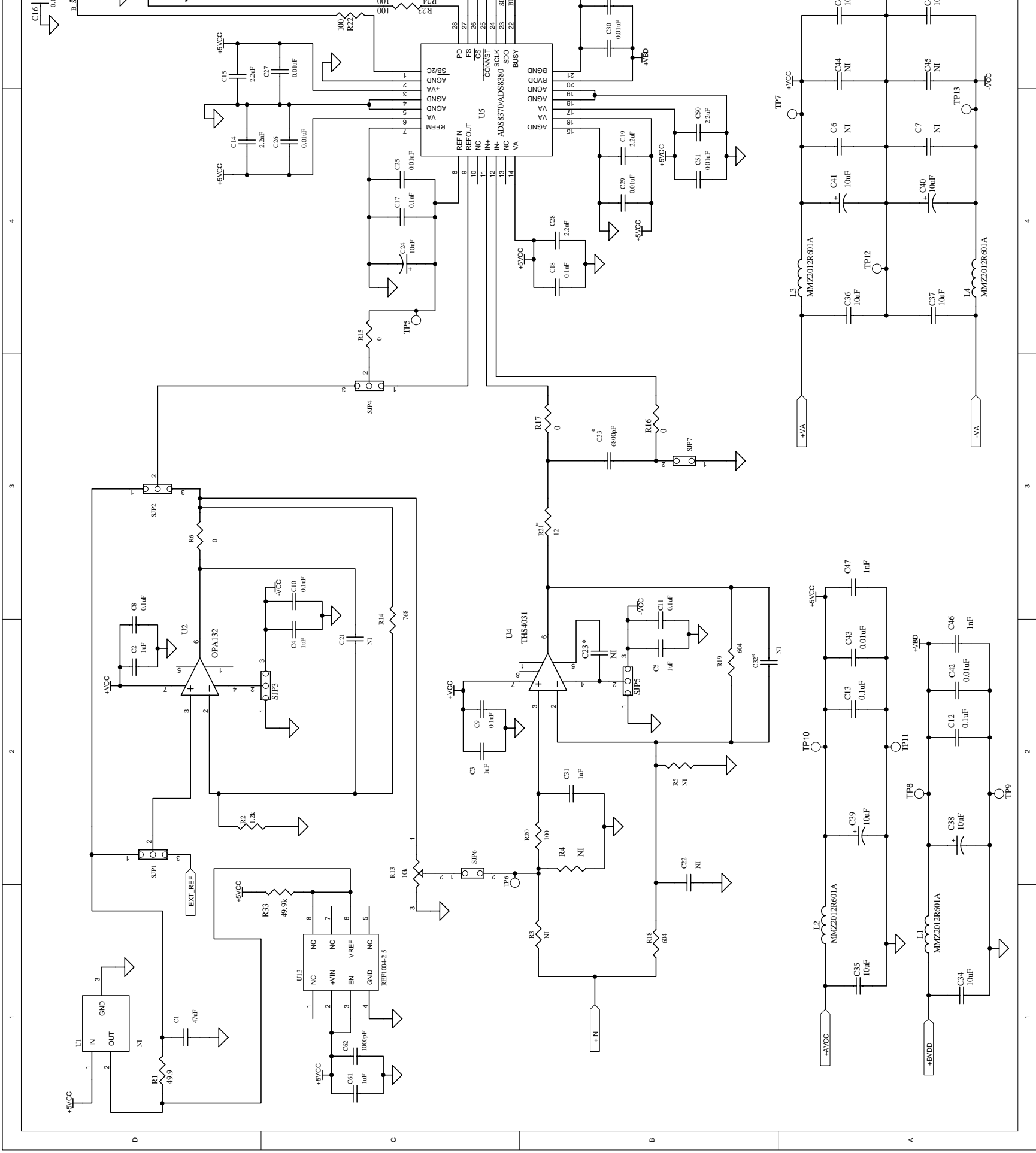

Figure 5. Bottom Layer

9 Schematics

Schematic diagrams are appended following this page.





IMPORTANT NOTICE

Texas Instruments Incorporated and its subsidiaries (TI) reserve the right to make corrections, modifications, enhancements, improvements, and other changes to its products and services at any time and to discontinue any product or service without notice. Customers should obtain the latest relevant information before placing orders and should verify that such information is current and complete. All products are sold subject to TI's terms and conditions of sale supplied at the time of order acknowledgment.

TI warrants performance of its hardware products to the specifications applicable at the time of sale in accordance with TI's standard warranty. Testing and other quality control techniques are used to the extent TI deems necessary to support this warranty. Except where mandated by government requirements, testing of all parameters of each product is not necessarily performed.

TI assumes no liability for applications assistance or customer product design. Customers are responsible for their products and applications using TI components. To minimize the risks associated with customer products and applications, customers should provide adequate design and operating safeguards.

TI does not warrant or represent that any license, either express or implied, is granted under any TI patent right, copyright, mask work right, or other TI intellectual property right relating to any combination, machine, or process in which TI products or services are used. Information published by TI regarding third-party products or services does not constitute a license from TI to use such products or services or a warranty or endorsement thereof. Use of such information may require a license from a third party under the patents or other intellectual property of the third party, or a license from TI under the patents or other intellectual property of TI.

Reproduction of information in TI data books or data sheets is permissible only if reproduction is without alteration and is accompanied by all associated warranties, conditions, limitations, and notices. Reproduction of this information with alteration is an unfair and deceptive business practice. TI is not responsible or liable for such altered documentation.

Resale of TI products or services with statements different from or beyond the parameters stated by TI for that product or service voids all express and any implied warranties for the associated TI product or service and is an unfair and deceptive business practice. TI is not responsible or liable for any such statements.

Following are URLs where you can obtain information on other Texas Instruments products and application solutions:

Products		Applications	
Amplifiers	amplifier.ti.com	Audio	www.ti.com/audio
Data Converters	dataconverter.ti.com	Automotive	www.ti.com/automotive
DSP	dsp.ti.com	Broadband	www.ti.com/broadband
Interface	interface.ti.com	Digital Control	www.ti.com/digitalcontrol
Logic	logic.ti.com	Military	www.ti.com/military
Power Mgmt	power.ti.com	Optical Networking	www.ti.com/opticalnetwork
Microcontrollers	microcontroller.ti.com	Security	www.ti.com/security
		Telephony	www.ti.com/telephony
		Video & Imaging	www.ti.com/video
		Wireless	www.ti.com/wireless

Mailing Address: Texas Instruments
Post Office Box 655303 Dallas, Texas 75265

Looking for pricing, stock, or lifecycle information?

Click below to explore more details on WIN SOURCE:

 [View ADS8380EVM](#) on WIN SOURCE

 [Texas Instruments](#) Information

Optimize Your Supply Chain with WIN SOURCE Solutions

-  Global Sourcing Solution
-  Obsolete Management
-  Cost Control Management
-  Shortage Management
-  Alternative Solution
-  Excess Inventory Management