



**THE DATASHEET OF
ADP121CB-1.2-EVALZ**



FEATURES

- Input voltage range:** 2.3 V to 5.5 V
- Output current range:** 0 mA to 150 mA
- Output voltage accuracy:** $\pm 1\%$
- Operating temperature range:** -40°C to $+125^{\circ}\text{C}$

GENERAL DESCRIPTION

The ADP121 evaluation boards are used to demonstrate the functionality of the [ADP121](#) linear regulators.

Simple device measurements such as line and load regulation, dropout, and ground current can be demonstrated with just a single voltage supply, a voltmeter, a current meter, and load resistors.

For more details about the ADP121 linear regulators, see the ADP121 data sheet.

EVALUATION BOARD BLOCK DIAGRAMS

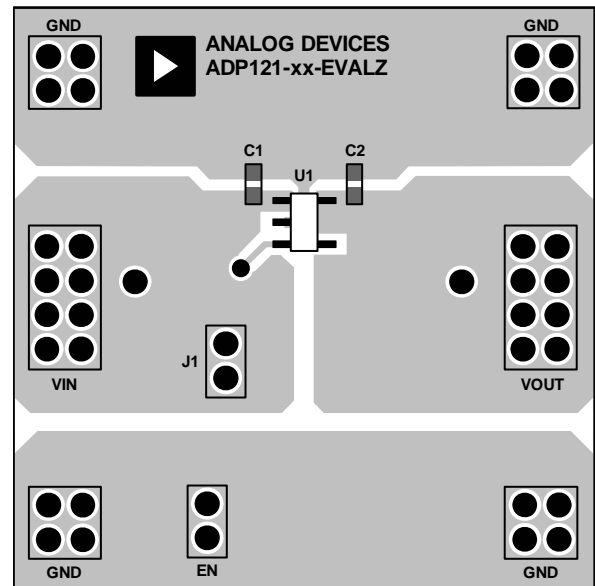

NOTES

- xx = 28 (2.8V), 30 (3.0V), 33 (3.3V).

Figure 1. TSOT

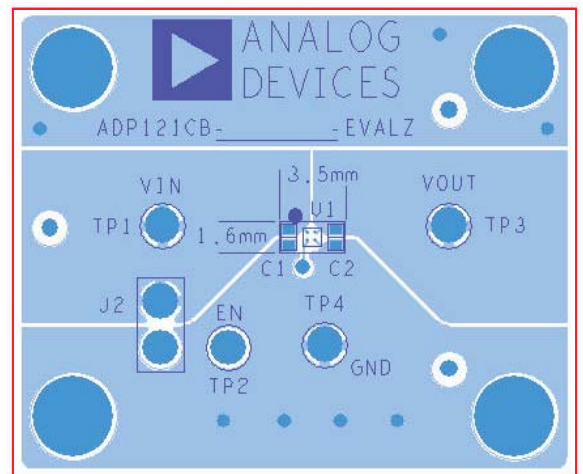

Figure 2. WLCSP

Rev. A

Evaluation boards are only intended for device evaluation and not for production purposes. Evaluation boards are supplied "as is" and without warranties of any kind, express, implied, or statutory including, but not limited to, any implied warranty of merchantability or fitness for a particular purpose. No license is granted by implication or otherwise under any patents or other intellectual property by application or use of evaluation boards. Information furnished by Analog Devices is believed to be accurate and reliable. However, no responsibility is assumed by Analog Devices for its use, nor for any infringements of patents or other rights of third parties that may result from its use. Analog Devices reserves the right to change devices or specifications at any time without notice. Trademarks and registered trademarks are the property of their respective owners. Evaluation boards are not authorized to be used in life support devices or systems.

TABLE OF CONTENTS

Features	1	Load Regulation	5
General Description	1	Dropout Voltage	5
Evaluation Board Block Diagrams	1	Measuring Ground Current	6
Revision History	2	Ground Current Consumption	7
Evaluation Board Hardware.....	3	Ordering Information.....	8
Evaluation Board Configurations	3	Bill of Materials.....	8
Measuring Output Voltage	4	Ordering Guide	8
Line Regulation.....	5	ESD Caution.....	8

REVISION HISTORY

4/09—Rev. 0 to Rev. A

Changes to Figure 2.....	1
Changes to Figure 5 and Figure 6.....	4
Changes to Figure 12.....	6
Changes to Ordering Guide	8

7/08—Revision 0: Initial Version

EVALUATION BOARD HARDWARE

EVALUATION BOARD CONFIGURATIONS

The EVAL-ADP121 is supplied with different components depending on which version is ordered. Components common to all versions are C1, C2, and J1 or J2. Figure 3 and Figure 4 show schematics for these evaluation board configurations.

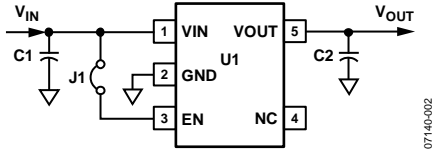

Figure 3. Evaluation Board Circuit Diagram, TSOT

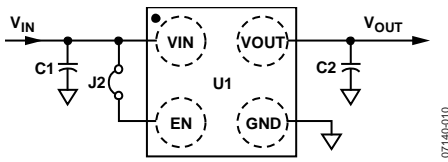

Figure 4. Evaluation Board Circuit Diagram, WLCSP

Table 1. Evaluation Board Hardware Components

Component	Function	Description
U1 ¹	Linear regulator	ADP121 low dropout linear regulator.
C1	Input capacitor	1 μ F input bypass capacitor.
C2	Output capacitor	1 μ F output capacitor. Required for stability and transient performance.
J1 or J2	Jumper	Jumper. Connects EN to IN for automatic startup.

¹ This component varies depending on the evaluation board type ordered.

MEASURING OUTPUT VOLTAGE

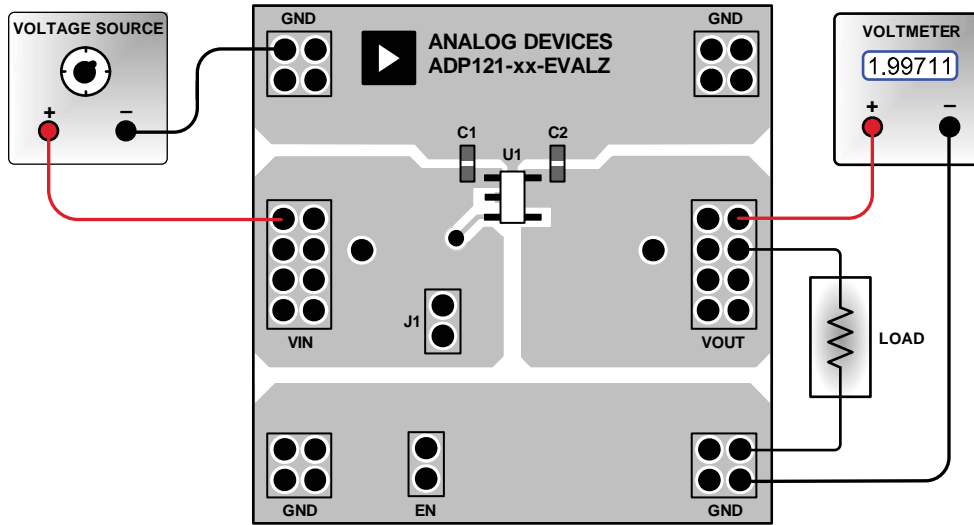

Figure 5. Output Voltage Measurement, TSOT

07140-003

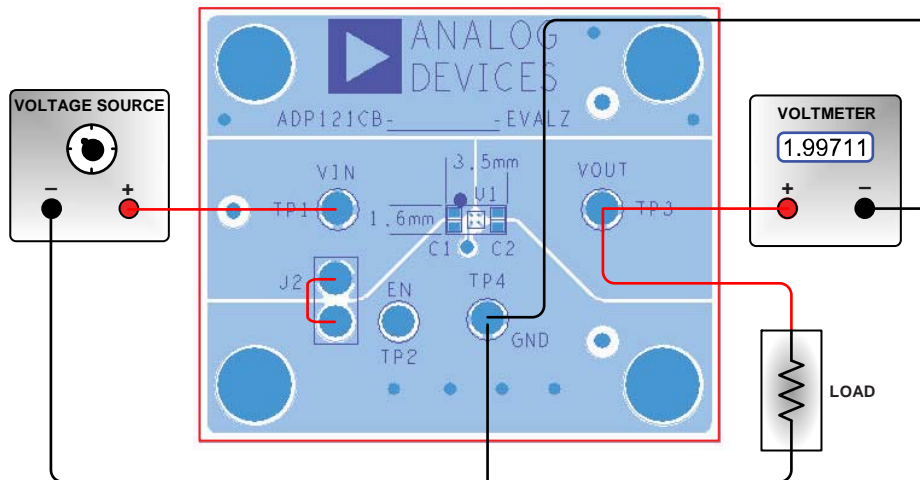

Figure 6. Output Voltage Measurement, WLCSP

07140-015

Figure 5 and Figure 6 show how the evaluation board can be connected to a voltage source and a voltmeter for basic output voltage accuracy measurements. A resistor can be used as the load for the regulator. Ensure that the resistor has a power rating adequate to handle the power expected to be dissipated across it. An electronic load can also be used as an alternative. Ensure that the voltage source can supply enough current for the expected load levels.

Use the following steps to connect to a voltage source and voltmeter:

1. Connect the negative terminal (–) of the voltage source to one of the GND pads on the evaluation board.
2. Connect the positive terminal (+) of the voltage source to the VIN pad of the evaluation board.
3. Connect a load between the VOUT pad and one of the GND pads.
4. Connect the negative terminal (–) of the voltmeter to one of the GND pads.
5. Connect the positive terminal (+) of the voltmeter to the VOUT pad.

The voltage source can now be turned on. If J1 or J2 is inserted (connecting EN to VIN for automatic startup), the regulator powers up.

If the load current is large, the user needs to connect the voltmeter as close as possible to the output capacitor to reduce the effects of IR drops.

LINE REGULATION

For line regulation measurements, the regulator’s output is monitored while its input is varied. For good line regulation, the output must change as little as possible with varying input levels. To ensure that the device is not in dropout mode during this measurement, V_{IN} must be varied between V_{OUT} nominal + 0.5 V (or 2.3 V, whichever is greater) and V_{IN} maximum. For example, an ADP121 with a fixed 1.8 V output needs V_{IN} to be varied between 2.3 V and 5.5 V. This measurement can be repeated under different load conditions. Figure 7 shows the typical line regulation performance of the ADP121 with fixed 1.8 V output.

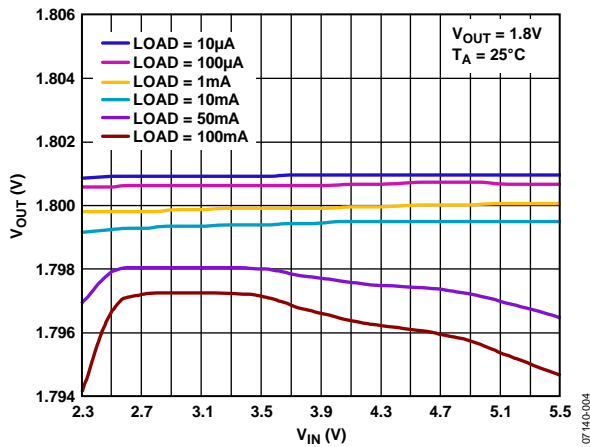

Figure 7. Output Voltage vs. Input Voltage

LOAD REGULATION

For load regulation measurements, the regulator’s output is monitored while the load is varied. For good load regulation, the output must change as little as possible with varying loads. The input voltage must be held constant during this measurement. The load current can be varied from 0 mA to 150 mA. Figure 8 shows the typical load regulation performance of the ADP121 with fixed 1.8 V output for an input voltage of 2.3 V.

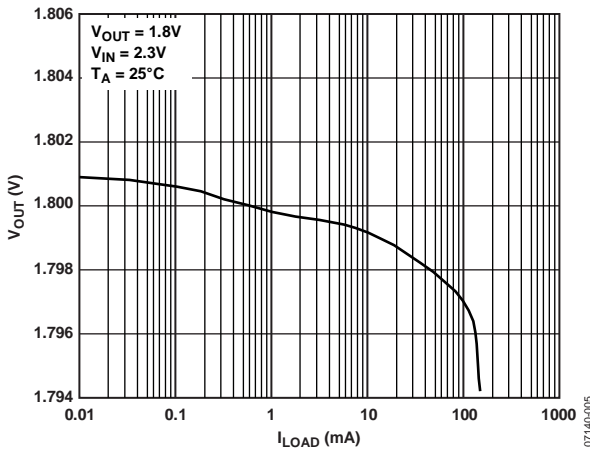

Figure 8. Output Voltage vs. Load Current

DROPOUT VOLTAGE

Dropout voltage can be measured using the configuration shown in Figure 5 and Figure 6. Dropout voltage is defined as the input-to-output voltage differential when the input voltage is set to the nominal output voltage. This applies only for output voltages above 2.3 V. Dropout voltage increases with larger loads. For more accurate measurements, a second voltmeter can be used to monitor the input voltage across the input capacitor. The input supply voltage may need to be adjusted to account for IR drops, especially if large load currents are used. Figure 9 and Figure 10 show the typical curves of dropout voltage measurements with different load currents for different output voltages.

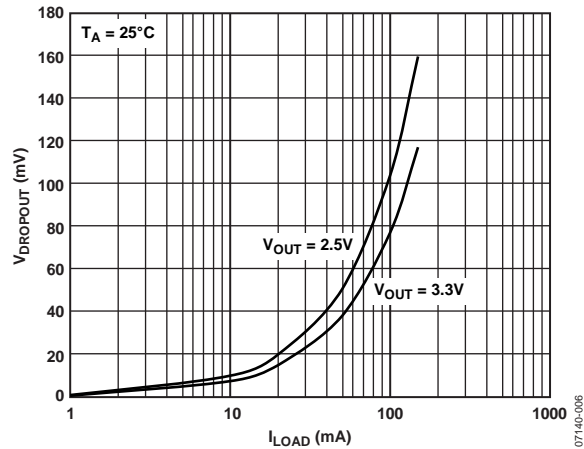

Figure 9. TSOT Dropout Voltage vs. Load Current

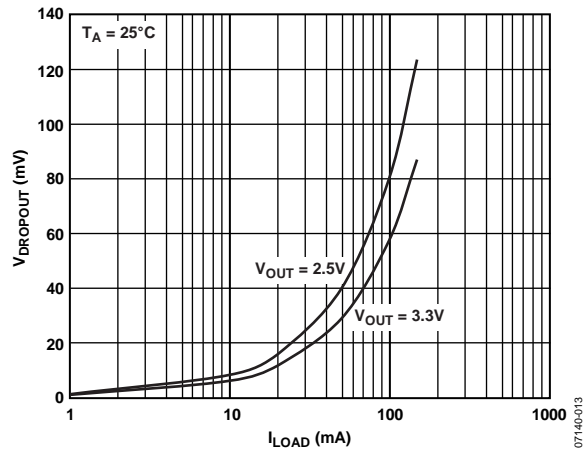

Figure 10. WLCSP Dropout Voltage vs. Load Current

MEASURING GROUND CURRENT

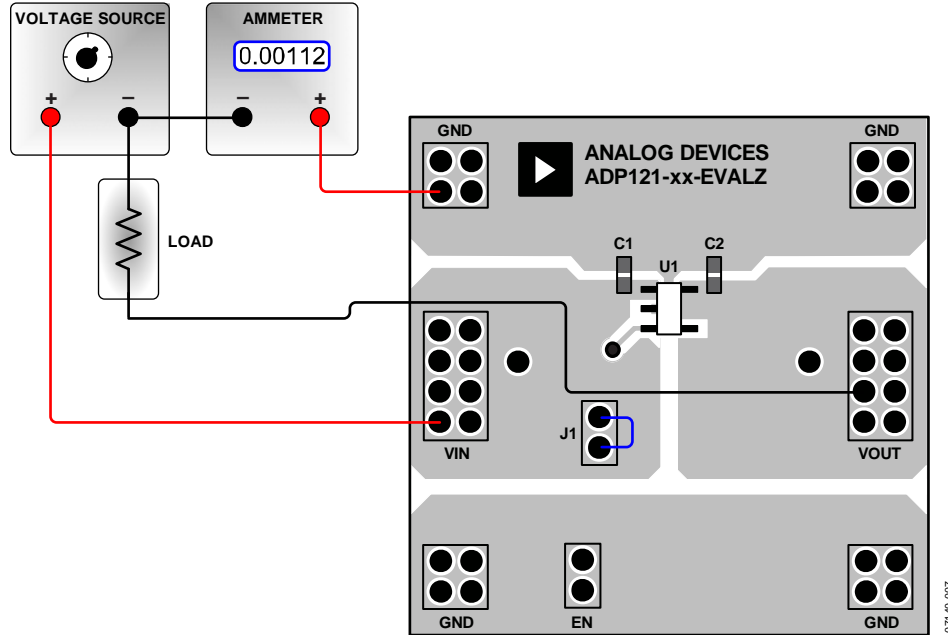

Figure 11. Ground Current Measurement, TSOT

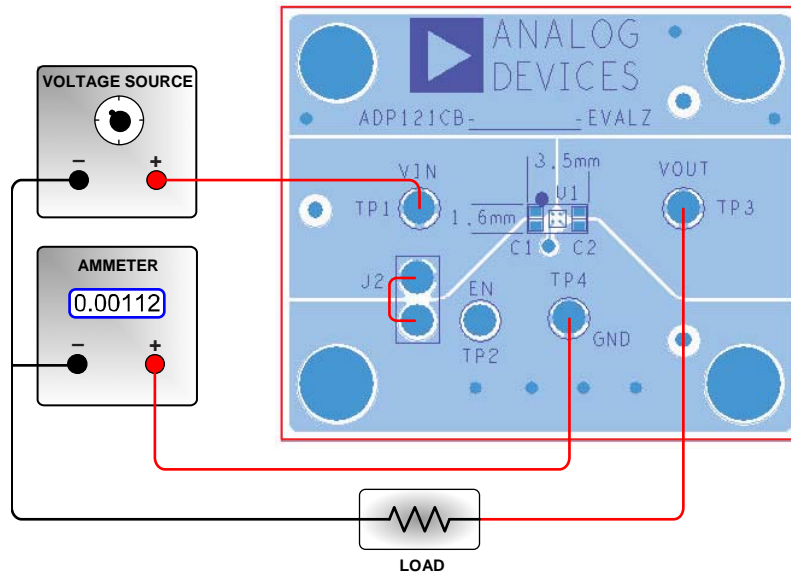

Figure 12. Ground Current Measurement, WLCSP

Figure 11 and Figure 12 show the evaluation board connected to a voltage source and an ammeter for ground current measurements. A resistor can be used as the load for the regulator. Ensure that the resistor has a power rating that is adequate to handle the power expected to be dissipated across it. An electronic load can be used as an alternative. Ensure that the voltage source used can supply enough current for the expected load levels.

Use the following steps to connect to a voltage source and ammeter:

1. Connect the positive terminal (+) of the voltage source to the VIN pad on the evaluation board.

2. Connect the positive terminal (+) of the ammeter to one of the GND pads of the evaluation board.
3. Connect the negative terminal (-) of the ammeter to the negative (-) terminal of the voltage source.
4. Connect a load between the negative (-) terminal of the voltage source and the VOUT pad of the evaluation board.

The voltage source can now be turned on. If J1 or J2 is inserted (connecting EN to VIN for automatic startup), the regulator powers up.

GROUND CURRENT CONSUMPTION

Ground current measurements can determine how much current the regulator’s internal circuits consume while the circuits perform the regulation function. To be efficient, the regulator needs to consume as little current as possible. Typically, the regulator uses the maximum current when supplying its largest load level (150 mA). Figure 13 shows the typical ground current consumption for various load levels at an input voltage of 2.3 V. When the device is disabled (EN = GND), the ground current drops to less than 1 μA.

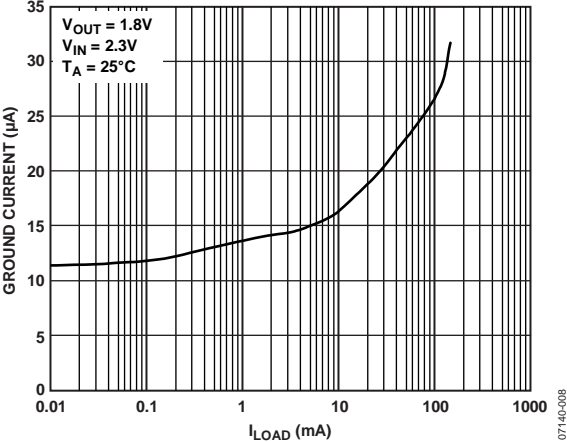

Figure 13. Ground Current vs. Load Current

07140-008

EVAL-ADP121

ORDERING INFORMATION

BILL OF MATERIALS

Table 2.

Qty	Reference Designator	Description	Manufacturer/Vendor	Vendor Part No.
2	C1, C2	Capacitor, MLCC, 1 μ F, 10 V, 0402, X5R	Murata or equivalent	GRM155R61A105KE15
1	J1 or J2	Header, single, STR, 2 pins	Digi-Key Corp.	S1012E-36-ND
1	U1	IC, LDO regulator	Analog Devices, Inc.	ADP121-AUJZ33R7 ADP121-AUJZ30R7 ADP121-AUJZ28R7 ADP121-ACBZ33R7 ADP121-ACBZ30R7 ADP121-ACBZ28R7 ADP121-ACBZ20R7 ADP121-ACBZ18R7

ORDERING GUIDE

Model	Output Voltage	Description
ADP121-3.3-EVALZ ¹	3.3	ADP121 3.3 V Output Evaluation Board [TSOT]
ADP121-3.0-EVALZ ¹	3.0	ADP121 3.0 V Output Evaluation Board [TSOT]
ADP121-2.8-EVALZ ¹	2.8	ADP121 2.8 V Output Evaluation Board [TSOT]
ADP121-1.8-EVALZ ¹	1.8	ADP121 1.8 V Output Evaluation Board [TSOT]
ADP121-1.5-EVALZ ¹	1.5	ADP121 1.5 V Output Evaluation Board [TSOT]
ADP121-1.2-EVALZ ¹	1.2	ADP121 1.2 V Output Evaluation Board [TSOT]
ADP121CB-3.3-EVALZ ¹	3.3	ADP121-1 3.3 V Output Evaluation Board [WLCSP]
ADP121CB-3.0-EVALZ ¹	3.0	ADP121-1 3.0 V Output Evaluation Board [WLCSP]
ADP121CB-2.8-EVALZ ¹	2.8	ADP121-1 2.8 V Output Evaluation Board [WLCSP]
ADP121CB-2.0-EVALZ ¹	2.0	ADP121-1 2.0 V Output Evaluation Board [WLCSP]
ADP121CB-1.8-EVALZ ¹	1.8	ADP121-1 1.8 V Output Evaluation Board [WLCSP]
ADP121CB-1.5-EVALZ ¹	1.5	ADP121 1.5 V Output Evaluation Board [WLCSP]
ADP121CB-1.2-EVALZ ¹	1.2	ADP121 1.2 V Output Evaluation Board [WLCSP]
ADP121-BL1-EVZ ¹		Blank Evaluation Board

¹ Z = RoHS Compliant Part.

ESD CAUTION



ESD (electrostatic discharge) sensitive device.

Charged devices and circuit boards can discharge without detection. Although this product features patented or proprietary protection circuitry, damage may occur on devices subjected to high energy ESD. Therefore, proper ESD precautions should be taken to avoid performance degradation or loss of functionality.

Looking for pricing, stock, or lifecycle information?

Click below to explore more details on WIN SOURCE:

- ⊖ [View ADP121CB-1.2-EVALZ on WIN SOURCE](#)
- ⊖ [Analog Devices Inc. Information](#)

Optimize Your Supply Chain with WIN SOURCE Solutions

- ✓ Global Sourcing Solution
- ✓ Obsolete Management
- ✓ Cost Control Management
- ✓ Shortage Management
- ✓ Alternative Solution
- ✓ Excess Inventory Management