



**THE DATASHEET OF
ADN4650BRWZ-RL7**



FEATURES

- 5 kV rms/3.75 kV rms LVDS isolator
- Complies with TIA/EIA-644-A LVDS standard
- Multiple dual-channel configurations
- Up to 600 Mbps switching with low jitter
 - 4.5 ns maximum propagation delay
 - 151 ps maximum peak-to-peak total jitter at 600 Mbps
 - 100 ps maximum pulse skew
 - 600 ps maximum part to part skew
- 2.5 V or 3.3 V supplies
- 75 dBc power supply ripple rejection and glitch immunity
- ±8 kV IEC 61000-4-2 ESD protection across isolation barrier
- High common-mode transient immunity: >25 kV/μs
- Passes EN55022 Class B radiated emissions limits with 600 Mbps PRBS
- Safety and regulatory approvals (20-lead SOIC package)**
 - UL: 5000 V rms for 1 minute per UL 1577
 - CSA Component Acceptance Notice 5A
 - VDE certificate of conformity
 - DIN V VDE V 0884-10 (VDE V 0884-10):2006-12
 - VIORM = 424 V peak
- Fail-safe output high for open, short, and terminated input conditions ([ADN4651/ADN4652](#))
- Operating temperature range: -40°C to +125°C
- Choice of package and isolation options
 - 3.75 kV rms in highly integrated 20-lead SSOP
 - 5 kV rms in 20-lead SOIC with 7.8 mm creepage/clearance

APPLICATIONS

- Analog front-end (AFE) isolation
- Data plane isolation
- Isolated high speed clock and data links
- Isolated serial peripheral interface (SPI) over LVDS

GENERAL DESCRIPTION

The [ADN4650/ADN4651/ADN4652](#)¹ are signal isolated, low voltage differential signaling (LVDS) buffers that operate at up to 600 Mbps with very low jitter.

The devices integrate Analog Devices, Inc., iCoupler® technology, enhanced for high speed operation, to provide galvanic isolation of the TIA/EIA-644-A compliant LVDS drivers and receivers. This technology allows drop-in isolation of an LVDS signal chain.

Multiple channel configurations are offered, and the LVDS receivers on the [ADN4651/ADN4652](#) include a fail-safe mechanism to

¹ Protected by U.S. Patents 5,952,849; 6,873,065; 6,903,578; and 7,075,329. Other patents are pending.

Rev. E **Document Feedback**
 Information furnished by Analog Devices is believed to be accurate and reliable. However, no responsibility is assumed by Analog Devices for its use, nor for any infringements of patents or other rights of third parties that may result from its use. Specifications subject to change without notice. No license is granted by implication or otherwise under any patent or patent rights of Analog Devices. Trademarks and registered trademarks are the property of their respective owners.

FUNCTIONAL BLOCK DIAGRAMS

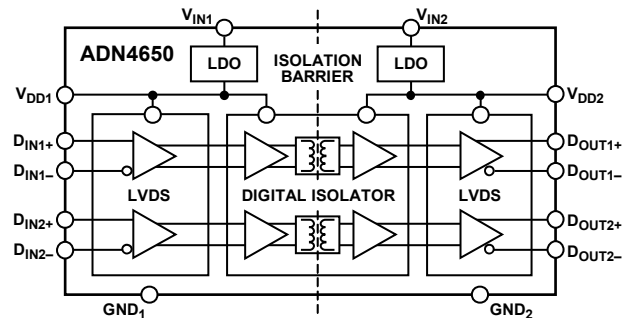

Figure 1.

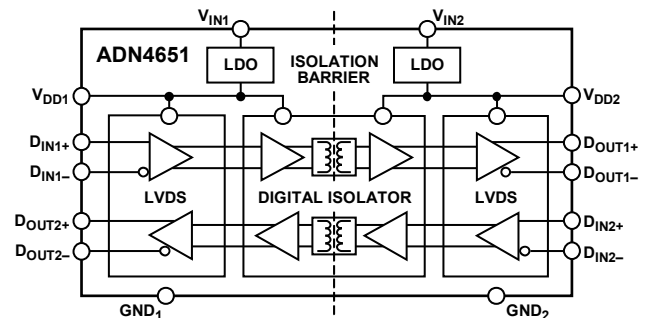

Figure 2.

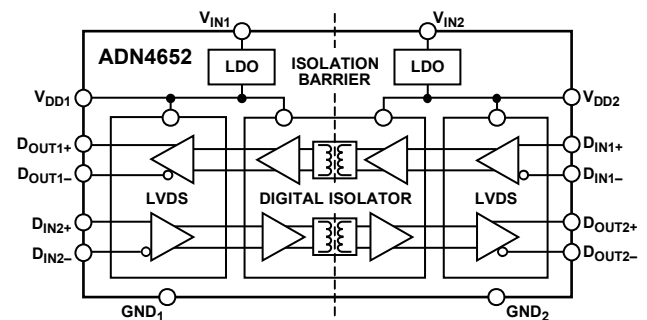

Figure 3.

ensure a Logic 1 on the corresponding LVDS driver output when the inputs are floating, shorted, or terminated, but not driven.

For high speed operation with low jitter, the LVDS and isolator circuits rely on a 2.5 V supply. An integrated on-chip low dropout regulator (LDO) can provide the required 2.5 V from an external 3.3 V power supply. The devices are fully specified over a wide industrial temperature range and are available in a 20-lead, wide body SOIC package with 5 kV rms isolation or a 20-lead SSOP package with 3.75 kV rms isolation.

TABLE OF CONTENTS

Features	1	Thermal Resistance	8
Applications	1	ESD Caution	8
General Description	1	Pin Configurations and Function Descriptions	9
Functional Block Diagrams	1	Typical Performance Characteristics	12
Revision History	2	Test Circuits and Switching Characteristics	17
Specifications	3	Theory of Operation	18
Receiver Input Threshold Test Voltages	4	Truth Table and Fail-Safe Receiver	18
Timing Specifications	4	Isolation	19
Insulation and Safety Related Specifications	5	PCB Layout	19
Package Characteristics	6	Magnetic Field Immunity	19
Regulatory Information	6	Insulation Lifetime	20
DIN V VDE V 0884-10 (VDE V 0884-10) Insulation Characteristics	6	Applications Information	22
Recommended Operating Conditions	7	Outline Dimensions	24
Absolute Maximum Ratings	8	Ordering Guide	24

REVISION HISTORY

6/2019—Rev. D to Rev. E

Changes to Features Section	1
Changed UL (Pending) Column to UL Column, CSA (Pending) Column to CSA Column, VDE (Pending) Column to VDE Column, Table 7, and DIN V VDE V 0884-10 (VDE V 0884-110) Insulation Characteristics (Pending) Section to DIN V VDE V 0884-10 (VDE V 0884-110) Insulation Characteristics Section	6

1/2017—Rev. C to Rev. D

Changes to Ordering Guide	24
---------------------------------	----

9/2016—Rev. B to Rev. C

Added 20-Lead SSOP	Throughout
Changes to Title, Features Section, and General Description	1
Added Table 5; Renumbered Sequentially	5
Change to Figure 5	7
Changes to PCB Layout Section	19
Changes to Surface Tracking Section	20
Updated Outline Dimensions	24
Changes to Ordering Guide	24

4/2016—Rev. A to Rev. B

Added ADN4652	Universal
Changes to Features Section and General Description Section	1
Added Figure 3; Renumbered Sequentially	1
Changes to Supply Current Parameter, Table 1	3

Changes to Skew Parameter and Fail-Safe Delay Parameter,

Table 3	4
Changes to Table 12	9
Moved Figure 7	10
Added Table 13	10
Added Figure 8 and Table 14, Renumbered Sequentially	11
Changes to PCB Layout Section	19
Changes to Ordering Guide	24

2/2016—Rev. 0 to Rev. A

Added ADN4650	Universal
Changes to Features Section and General Description Section	1
Added Figure 1; Renumbered Sequentially	1
Changes to Supply Current Parameter, Table 1	3
Changes to Skew Parameter and Fail-Safe Delay Parameter, Table 3	4
Added Figure 5	9
Changes to Table 12	9
Changes to Figure 30 Caption and Figure 31 Caption	14
Change to Figure 34	15
Changes to Truth Table and Fail-Safe Receiver Section	16
Added Table 13; Renumbered Sequentially	16
Change to Applications Information Section	20
Added Figure 41	20
Changes to Ordering Guide	22

11/2015—Revision 0: Initial Version

SPECIFICATIONS

For all minimum/maximum specifications, $V_{DD1} = V_{DD2} = 2.375\text{ V}$ to 2.625 V , $T_A = T_{MIN}$ to T_{MAX} , unless otherwise noted. For all typical specifications, $V_{DD1} = V_{DD2} = 2.5\text{ V}$, $T_A = 25^\circ\text{C}$.

Table 1.

Parameter	Symbol	Min	Typ	Max	Unit	Test Conditions/Comments
INPUTS (RECEIVERS)						
Input Threshold						See Figure 36 and Table 2
High	V_{TH}			100	mV	
Low	V_{TL}	-100			mV	
Differential Input Voltage	$ V_{ID} $	100			mV	See Figure 36 and Table 2
Input Common-Mode Voltage	V_{IC}	$0.5 V_{ID} $		$2.4 - 0.5 V_{ID} $	V	See Figure 36 and Table 2
Input Current	I_{IH}, I_{IL}	-5		+5	μA	$D_{INx\pm} = V_{DD}$ or 0 V , other input = 1.2 V , $V_{DD} = 2.5\text{ V}$ or 0 V
Differential Input Capacitance ¹	$C_{INx\pm}$		2		pF	$D_{INx\pm} = 0.4 \sin(30 \times 10^6 \pi t)\text{ V} + 0.5\text{ V}$, other input = 1.2 V
OUTPUTS (DRIVERS)						
Differential Output Voltage	$ V_{OD} $	250	310	450	mV	See Figure 34 and Figure 35, $R_L = 100\ \Omega$
V_{OD} Magnitude Change	$ \Delta V_{OD} $			50	mV	See Figure 34 and Figure 35, $R_L = 100\ \Omega$
Offset Voltage	V_{OS}	1.125	1.17	1.375	V	See Figure 34, $R_L = 100\ \Omega$
V_{OS} Magnitude Change	ΔV_{OS}			50	mV	See Figure 34, $R_L = 100\ \Omega$
V_{OS} Peak-to-Peak ¹	$V_{OS(PP)}$			150	mV	See Figure 34, $R_L = 100\ \Omega$
Output Short-Circuit Current	I_{OS}			-20	mA	$D_{OUTx\pm} = 0\text{ V}$
				12	mA	$ V_{OD} = 0\text{ V}$
Differential Output Capacitance ¹	$C_{OUTx\pm}$		5		pF	$D_{OUTx\pm} = 0.4 \sin(30 \times 10^6 \pi t)\text{ V} + 0.5\text{ V}$, other input = 1.2 V , V_{DD1} or $V_{DD2} = 0\text{ V}$
POWER SUPPLY						
Supply Current	$I_{DD1}, I_{IN1}, I_{DD2},$ or I_{IN2}					
ADN4651/ADN4652 Only				55	mA	No output load, inputs with $100\ \Omega$, no applied $ V_{ID} $
ADN4650 Only				58	mA	All outputs loaded, $R_L = 100\ \Omega$, $f = 300\text{ MHz}$
				50	mA	No output load, inputs with $100\ \Omega$, $ V_{ID} = 200\text{ mV}$
				60	mA	All outputs loaded, $R_L = 100\ \Omega$, $f = 300\text{ MHz}$
LDO Input Range	V_{IN1} or V_{IN2}	3.0	3.3	3.6	V	No external supply on V_{DD1} or V_{DD2}
LDO Output Range	V_{DD1} or V_{DD2}	2.375	2.5	2.625	V	
Power Supply Ripple Rejection, Phase Spur Level	PSRR		-75		dBc	Phase spur level on $D_{OUTx\pm}$ with 300 MHz clock on $D_{INx\pm}$ and applied ripple of 100 kHz , 100 mV p-p on a 2.5 V supply to V_{DD1} or V_{DD2}
COMMON-MODE TRANSIENT IMMUNITY ²	$ CM $	25	50		kV/ μs	$V_{CM} = 1000\text{ V}$, transient magnitude = 800 V

¹ These specifications are guaranteed by design and characterization.

² $|CM|$ is the maximum common-mode voltage slew rate that can be sustained while maintaining any D_{OUTx+}/D_{OUTx-} pin in the same state as the corresponding D_{INx+}/D_{INx-} pin (no change on output), or producing the expected transition on any D_{OUTx+}/D_{OUTx-} pin if the applied common-mode transient edge is coincident with a data transition on the corresponding D_{INx+}/D_{INx-} pin. The common-mode voltage slew rates apply to both rising and falling common-mode voltage edges.

RECEIVER INPUT THRESHOLD TEST VOLTAGES

Table 2. Test Voltages for Receiver Operation

Applied Voltages		Input Voltage, Differential (V _{ID}) (V)	Input Voltage, Common-Mode (V _{IC}) (V)	Driver Output (V _{OD}) (mV)
D _{INx+} (V)	D _{INx-} (V)			
1.25	1.15	0.1	1.2	>250
1.15	1.25	-0.1	+1.2	<-250
2.4	2.3	0.1	2.35	>250
2.3	2.4	-0.1	+2.35	<-250
0.1	0	0.1	0.05	>250
0	0.1	-0.1	+0.05	<-250
1.5	0.9	0.6	1.2	>250
0.9	1.5	-0.6	+1.2	<-250
2.4	1.8	0.6	2.1	>250
1.8	2.4	-0.6	+2.1	<-250
0.6	0	0.6	0.3	>250
0	0.6	-0.6	+0.3	<-250

TIMING SPECIFICATIONS

For all minimum/maximum specifications, V_{DD1} = V_{DD2} = 2.375 V to 2.625 V, T_A = T_{MIN} to T_{MAX}, unless otherwise noted. All typical specifications, V_{DD1} = V_{DD2} = 2.5 V, T_A = 25°C.

Table 3.

Parameter	Symbol	Min	Typ	Max ¹	Unit	Test Conditions/Comments
PROPAGATION DELAY	t _{PLH} , t _{PHL}		4	4.5	ns	See Figure 37, from any D _{INx+} /D _{INx-} to D _{OUTx+} /D _{OUTx-}
SKEW						See Figure 37, across all D _{OUTx+} /D _{OUTx-}
Duty Cycle ²	t _{SK(D)}			100	ps	
Channel to Channel ³	t _{SK(CH)}		200	500	ps	
			150	300	ps	ADN4650 only
Part to Part ⁴	t _{SK(PP)}			600	ps	ADN4650, ADN4651, ADN4652, or combinations
				500	ps	ADN4650 to ADN4650 only
JITTER ⁵						See Figure 37, for any D _{OUTx+} /D _{OUTx-}
Random Jitter, RMS ⁶ (1σ)	t _{RJ(RMS)}		2.6	4.8	ps rms	300 MHz clock input
Deterministic Jitter ^{7,8}	t _{DJ(PP)}		30	96	ps	600 Mbps, 2 ²³ – 1 PRBS
With Crosstalk	t _{DJC(PP)}		30		ps	600 Mbps, 2 ²³ – 1 PRBS
Total Jitter at BER 1 × 10 ⁻¹²	t _{TJ(PP)}		70	151	ps	300 MHz/600 Mbps, 2 ²³ – 1 PRBS ⁹
Additive Phase Jitter	t _{ADDJ}		387		fs rms	100 Hz to 100 kHz, f _{OUT} = 10 MHz ¹⁰
			376		fs rms	12 kHz to 20 MHz, f _{OUT} = 300 MHz ¹¹
RISE/FALL TIME	t _R , t _F			350	ps	See Figure 37, any D _{OUTx+} /D _{OUTx-} , 20% to 80%, R _L = 100 Ω, C _L = 5 pF
FAIL-SAFE DELAY ¹²	t _{FSH} , t _{FSL}		1	1.2	μs	ADN4651/ADN4652 only; see Figure 37 and Figure 4, any D _{OUTx+} /D _{OUTx-} , R _L = 100 Ω
MAXIMUM DATA RATE		600			Mbps	

¹ These specifications are guaranteed by design and characterization.

² Duty cycle or pulse skew is the magnitude of the maximum difference between t_{PLH} and t_{PHL} for any channel of a device, that is, |t_{PLH} – t_{PHL}|.

³ Channel to channel or output skew is the difference between the largest and smallest values of t_{PLHX} within a device or the difference between the largest and smallest values of t_{PHLX} within a device, whichever of the two is greater.

⁴ Part to part output skew is the difference between the largest and smallest values of t_{PLHX} across multiple devices or the difference between the largest and smallest values of t_{PHLX} across multiple devices, whichever of the two is greater.

⁵ Jitter parameters are guaranteed by design and characterization. Values do not include stimulus jitter. V_{ID} = 400 mV p-p, t_R = t_F = 0.3 ns (20% to 80%).

⁶ This specification is measured over a population of ~7,000,000 edges.

⁷ Peak-to-peak jitter specifications include jitter due to pulse skew (t_{SK(D)}).

⁸ This specification is measured over a population of ~3,000,000 edges.

⁹ Using the formula t_{TJ(PP)} = 14 × t_{RJ(RMS)} + t_{DJ(PP)}.

¹⁰ With input phase jitter of 250 fs rms subtracted.

¹¹ With input phase jitter of 100 fs rms subtracted.

¹² The fail-safe delay is the delay before D_{OUTx±} is switched high to reflect idle input to D_{INx±} (|V_{ID}| < 100 mV, open or short/terminated input condition).

Timing Diagram

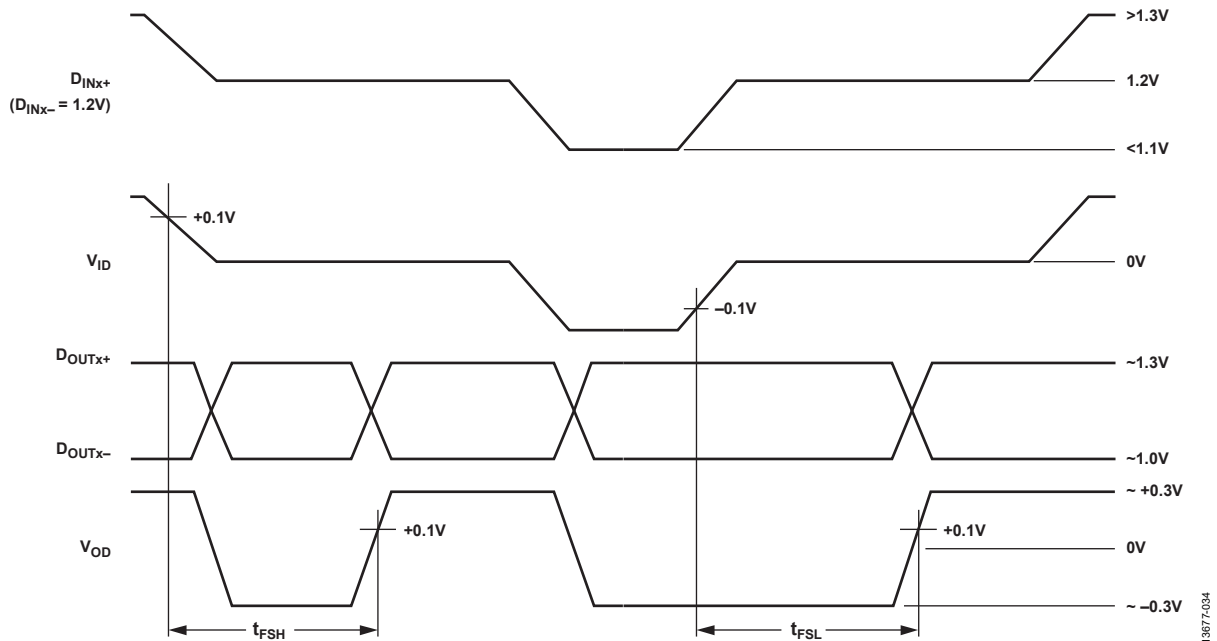

Figure 4. Fail-Safe Timing Diagram

13877-034

INSULATION AND SAFETY RELATED SPECIFICATIONS

For additional information, see www.analog.com/icouplersafety.

Table 4. 20-Lead SOIC Package

Parameter	Symbol	Value	Unit	Test Conditions/Comments
Rated Dielectric Insulation Voltage		5000	V rms	1-minute duration
Minimum External Air Gap (Clearance)	L (I01)	7.8	mm min	Measured from input terminals to output terminals, shortest distance through air
Minimum External Tracking (Creepage)	L (I02)	7.8	mm min	Measured from input terminals to output terminals, shortest distance path along body
Minimum Clearance in the Plane of the Printed Circuit Board (PCB Clearance)	L (PCB)	8.1	mm min	Measured from input terminals to output terminals, shortest distance through air, line of sight, in the PCB mounting plane
Minimum Internal Gap (Internal Clearance)		17	$\mu\text{m min}$	Insulation distance through insulation
Tracking Resistance (Comparative Tracking Index)	CTI	>400	V	DIN IEC 112/VDE 0303 Part 1
Material Group		II		Material Group (DIN VDE 0110, 1/89, Table 1)

Table 5. 20-Lead SSOP Package

Parameter	Symbol	Value	Unit	Test Conditions/Comments
Rated Dielectric Insulation Voltage		3750	V rms	1-minute duration
Minimum External Air Gap (Clearance)	L (I01)	5.3	mm min	Measured from input terminals to output terminals, shortest distance through air
Minimum External Tracking (Creepage)	L (I02)	5.3	mm min	Measured from input terminals to output terminals, shortest distance path along body
Minimum Clearance in the Plane of the Printed Circuit Board (PCB Clearance)	L (PCB)	5.6	mm min	Measured from input terminals to output terminals, shortest distance through air, line of sight, in the PCB mounting plane
Minimum Internal Gap (Internal Clearance)		22	$\mu\text{m min}$	Insulation distance through insulation
Tracking Resistance (Comparative Tracking Index)	CTI	>400	V	DIN IEC 112/VDE 0303 Part 1
Material Group		II		Material Group (DIN VDE 0110, 1/89, Table 1)

PACKAGE CHARACTERISTICS

Table 6.

Parameter	Symbol	Min	Typ	Max	Unit	Test Conditions/Comments
Resistance (Input to Output) ¹	R _{I-O}		10 ¹³		Ω	
Capacitance (Input to Output) ¹	C _{I-O}		2.2		pF	f = 1 MHz
Input Capacitance ²	C _I		3.7		pF	
IC Junction to Ambient Thermal Resistance	θ _{JA}					Thermal simulation with 4-layer standard JEDEC PCB
20-Lead SOIC			45.7		°C/W	
20-Lead SSOP			69.6		°C/W	

¹ The device is considered a 2-terminal device: Pin 1 through Pin 10 are shorted together, and Pin 11 through Pin 20 are shorted together.

² Input capacitance is from any input data pin to ground.

REGULATORY INFORMATION

See Table 12 and the Insulation Lifetime section for details regarding recommended maximum working voltages for specific cross-isolation waveforms and insulation levels.

Table 7.

UL	CSA	VDE
To Be Recognized Under UL 1577 Component Recognition Program ¹	To be approved under CSA Component Acceptance Notice 5A	To be certified according to DIN V VDE V 0884-10 (VDE V 0884-10):2006-12 ²
Single Protection, Isolation Voltage 20-lead SOIC, 5000 V rms 20-lead SSOP, 3750 V rms		Reinforced insulation, V _{IORM} = 424 V peak, V _{IOSM} = 6000 V peak
File E214100	File 205078	Basic insulation, V _{IORM} = 424 V peak, V _{IOSM} = 10,000 V peak File 2471900-4880-0001

¹ In accordance with UL 1577, each ADN4650/ADN4651/ADN4652 is proof tested by applying an insulation test voltage ≥6000 V rms (20-lead SOIC) or ≥4500 V rms (20-lead SSOP) for 1 sec.

² In accordance with DIN V VDE V 0884-10, each ADN4650/ADN4651/ADN4652 is proof tested by applying an insulation test voltage ≥795 V peak for 1 sec (partial discharge detection limit = 5 pC).

DIN V VDE V 0884-10 (VDE V 0884-10) INSULATION CHARACTERISTICS

This isolator is suitable for reinforced electrical isolation only within the safety limit data. Protective circuits ensure the maintenance of the safety data.

Table 8.

Description	Test Conditions/Comments	Symbol	Characteristic	Unit
Installation Classification per DIN VDE 0110 For Rated Mains Voltage ≤ 150 V rms For Rated Mains Voltage ≤ 300 V rms For Rated Mains Voltage ≤ 600 V rms			I to IV I to IV I to III	
Climatic Classification			40/125/21	
Pollution Degree per DIN VDE 0110, Table 1			2	
Maximum Working Insulation Voltage		V _{IORM}	424	V peak
Input to Output Test Voltage, Method B1	V _{IORM} × 1.875 = V _{pd(m)} , 100% production test, t _{ini} = t _m = 1 sec, partial discharge < 5 pC	V _{pd(m)}	795	V peak
Input to Output Test Voltage, Method A After Environmental Tests Subgroup 1	V _{IORM} × 1.5 = V _{pd(m)} , t _{ini} = 60 sec, t _m = 10 sec, partial discharge < 5 pC	V _{pd(m)}	636	V peak
After Input and/or Safety Test Subgroup 2 and Subgroup 3	V _{IORM} × 1.2 = V _{pd(m)} , t _{ini} = 60 sec, t _m = 10 sec, partial discharge < 5 pC		509	V peak
Highest Allowable Overvoltage		V _{IOTM}	5000	V peak
Surge Isolation Voltage				
Basic	V _{PEAK} = 12.8 kV, 1.2 μs rise time, 50 μs, 50% fall time	V _{IOSM}	10,000	V peak
Reinforced	V _{PEAK} = 10 kV, 1.2 μs rise time, 50 μs, 50% fall time	V _{IOSM}	6000	V peak

Description	Test Conditions/Comments	Symbol	Characteristic	Unit
Maximum Junction Temperature	(see Figure 5)	T_S	150	°C
Total Power Dissipation at 25°C		P_S	2.78	W
20-Lead SOIC			1.8	W
20-Lead SSOP			>10 ⁹	Ω
Insulation Resistance at T_S	$V_{IO} = 500\text{ V}$	R_S		

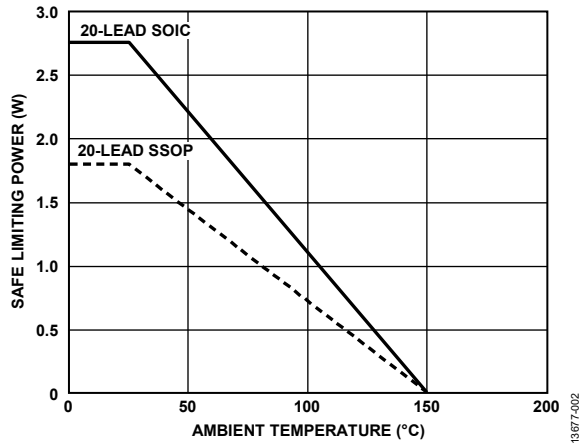

Figure 5. Thermal Derating Curve, Dependence of Safety Limiting Values with Ambient Temperature per DIN V VDE V 0884-10

RECOMMENDED OPERATING CONDITIONS

Table 9.

Parameter	Symbol	Rating
Operating Temperature	T_A	-40°C to +125°C
Supply Voltages		
Supply to LDO	V_{IN1}, V_{IN2}	3.0 V to 3.6 V
LDO Bypass, V_{INx} Shorted to V_{DDx}	V_{DD1}, V_{DD2}	2.375 V to 2.625 V

ABSOLUTE MAXIMUM RATINGS

Table 10.

Parameter	Rating
V_{IN1} to GND_1/V_{IN2} to GND_2	-0.3 V to +6.5 V
V_{DD1} to GND_1/V_{DD2} to GND_2	-0.3 V to +2.8 V
Input Voltage (D_{INx+} , D_{INx-}) to GND_x on the Same Side	-0.3 V to $V_{DD} + 0.3$ V
Output Voltage (D_{OUTx+} , D_{OUTx-}) to GND_x on the Same Side	-0.3 V to $V_{DD} + 0.3$ V
Short-Circuit Duration (D_{OUTx+} , D_{OUTx-}) to GND_x on the Same Side	Continuous
Operating Temperature Range	-40°C to +125°C
Storage Temperature Range	-65°C to +150°C
Junction Temperature (T_J Maximum)	150°C
Power Dissipation	$(T_J \text{ maximum} - T_A)/\theta_{JA}$
ESD	
Human Body Model (All Pins to Respective GND_x , 1.5 k Ω , 100 pF)	± 4 kV
IEC 61000-4-2 (LVDS Pins to Isolated GND_x Across Isolation Barrier)	
20-Lead SOIC	± 8 kV
20-Lead SSOP	± 7 kV

Stresses at or above those listed under Absolute Maximum Ratings may cause permanent damage to the product. This is a stress rating only; functional operation of the product at these or any other conditions above those indicated in the operational section of this specification is not implied. Operation beyond the maximum operating conditions for extended periods may affect product reliability.

Table 12. Maximum Continuous Working Voltage¹

Parameter	Rating		Constraint
	20-Lead SOIC	20-Lead SSOP	
AC Voltage			
Bipolar Waveform			
Basic Insulation	495 V peak	424 V peak	50-year minimum insulation lifetime for 1% failure
Reinforced Insulation	495 V peak	424 V peak	50-year minimum insulation lifetime for 1% failure
Unipolar Waveform			
Basic Insulation	990 V peak	848 V peak	50-year minimum insulation lifetime for 1% failure
Reinforced Insulation	875 V peak	620 V peak	Lifetime limited by package creepage, maximum approved working voltage
DC Voltage			
Basic Insulation	1079 V peak	754 V peak	Lifetime limited by package creepage, maximum approved working voltage
Reinforced Insulation	536 V peak	380 V peak	Lifetime limited by package creepage, maximum approved working voltage

¹ The maximum continuous working voltage refers to the continuous voltage magnitude imposed across the isolation barrier. See the Insulation Lifetime section for more details.

THERMAL RESISTANCE

θ_{JA} is specified for the worst case conditions, that is, a device soldered in a circuit board for surface-mount packages.

Table 11. Thermal Resistance

Package Type	θ_{JA}	Unit
20-Lead SOIC	45.7	°C/W
20-lead SSOP	69.6	°C/W

ESD CAUTION



ESD (electrostatic discharge) sensitive device. Charged devices and circuit boards can discharge without detection. Although this product features patented or proprietary protection circuitry, damage may occur on devices subjected to high energy ESD. Therefore, proper ESD precautions should be taken to avoid performance degradation or loss of functionality.

PIN CONFIGURATIONS AND FUNCTION DESCRIPTIONS

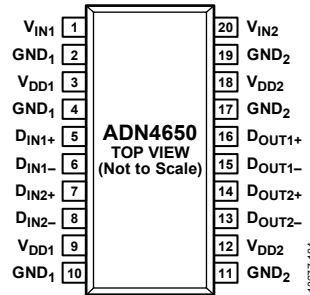

Figure 6. ADN4650 Pin Configuration

Table 13. ADN4650 Pin Function Descriptions

Pin No.	Mnemonic	Description
1	V _{IN1}	Optional 3.3 V Power Supply/LDO Input for Side 1. Bypass V _{IN1} to GND ₁ using a 1 μ F capacitor. Alternatively, if using a 2.5 V supply, connect V _{IN1} directly to V _{DD1} .
2, 4, 10	GND ₁	Ground, Side 1.
3, 9	V _{DD1}	2.5 V Power Supply for Side 1. Connect both pins externally and bypass to GND ₁ with 0.1 μ F capacitors. If supplying 3.3 V to V _{IN1} , connect a 1 μ F capacitor between Pin 3 and GND ₁ for proper regulation of the 2.5 V output of the internal LDO.
5	D _{IN1+}	Noninverted Differential Input 1.
6	D _{IN1-}	Inverted Differential Input 1.
7	D _{IN2+}	Noninverted Differential Input 2.
8	D _{IN2-}	Inverted Differential Input 2.
11, 17, 19	GND ₂	Ground, Side 2.
12, 18	V _{DD2}	2.5 V Power Supply for Side 2. Connect both pins externally and bypass to GND ₂ with 0.1 μ F capacitors. If supplying 3.3 V to V _{IN2} , connect a 1 μ F capacitor between Pin 18 and GND ₂ for proper regulation of the 2.5 V output of the internal LDO.
13	D _{OUT2-}	Inverted Differential Output 2.
14	D _{OUT2+}	Noninverted Differential Output 2.
15	D _{OUT1-}	Inverted Differential Output 1.
16	D _{OUT1+}	Noninverted Differential Output 1.
20	V _{IN2}	Optional 3.3 V Power Supply/LDO Input for Side 2. Bypass V _{IN2} to GND ₂ using a 1 μ F capacitor. Alternatively, if using a 2.5 V supply, connect V _{IN2} directly to V _{DD2} .

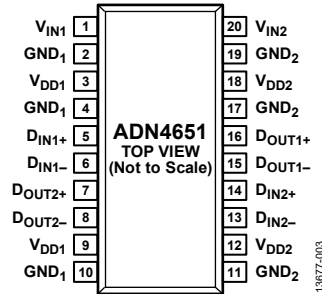

Figure 7. ADN4651 Pin Configuration

Table 14. ADN4651 Pin Function Descriptions

Pin No.	Mnemonic	Description
1	V _{IN1}	Optional 3.3 V Power Supply/LDO Input for Side 1. Bypass V _{IN1} to GND ₁ using a 1 μF capacitor. Alternatively, if using a 2.5 V supply, connect V _{IN1} directly to V _{DD1} .
2, 4, 10	GND ₁	Ground, Side 1.
3, 9	V _{DD1}	2.5 V Power Supply for Side 1. Connect both pins externally and bypass to GND ₁ with 0.1 μF capacitors. If supplying 3.3 V to V _{IN1} , connect a 1 μF capacitor between Pin 3 and GND ₁ for proper regulation of the 2.5 V output of the internal LDO.
5	D _{IN1+}	Noninverted Differential Input 1.
6	D _{IN1-}	Inverted Differential Input 1.
7	D _{OUT2+}	Noninverted Differential Output 2.
8	D _{OUT2-}	Inverted Differential Output 2.
11, 17, 19	GND ₂	Ground, Side 2.
12, 18	V _{DD2}	2.5 V Power Supply for Side 2. Connect both pins externally and bypass to GND ₂ with 0.1 μF capacitors. If supplying 3.3 V to V _{IN2} , connect a 1 μF capacitor between Pin 18 and GND ₂ for proper regulation of the 2.5 V output of the internal LDO.
13	D _{IN2-}	Inverted Differential Input 2.
14	D _{IN2+}	Noninverted Differential Input 2.
15	D _{OUT1-}	Inverted Differential Output 1.
16	D _{OUT1+}	Noninverted Differential Output 1.
20	V _{IN2}	Optional 3.3 V Power Supply/LDO Input for Side 2. Bypass V _{IN2} to GND ₂ using a 1 μF capacitor. Alternatively, if using a 2.5 V supply, connect V _{IN2} directly to V _{DD2} .

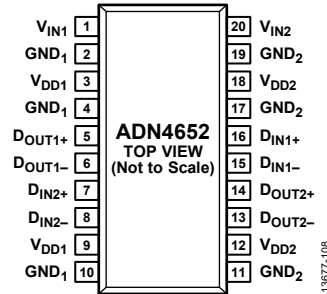

Figure 8. ADN4652 Pin Configuration

Table 15. ADN4652 Pin Function Descriptions

Pin No.	Mnemonic	Description
1	V _{IN1}	Optional 3.3 V Power Supply/LDO Input for Side 1. Bypass V _{IN1} to GND ₁ using a 1 μ F capacitor. Alternatively, if using a 2.5 V supply, connect V _{IN1} directly to V _{DD1} .
2, 4, 10	GND ₁	Ground, Side 1.
3, 9	V _{DD1}	2.5 V Power Supply for Side 1. Connect both pins externally and bypass to GND ₁ with 0.1 μ F capacitors. If supplying 3.3 V to V _{IN1} , connect a 1 μ F capacitor between Pin 3 and GND ₁ for proper regulation of the 2.5 V output of the internal LDO.
5	D _{OUT1+}	Noninverted Differential Output 1.
6	D _{OUT1-}	Inverted Differential Output 1.
7	D _{IN2+}	Noninverted Differential Input 2.
8	D _{IN2-}	Inverted Differential Input 2.
11, 17, 19	GND ₂	Ground, Side 2.
12, 18	V _{DD2}	2.5 V Power Supply for Side 2. Connect both pins externally and bypass to GND ₂ with 0.1 μ F capacitors. If supplying 3.3 V to V _{IN2} , connect a 1 μ F capacitor between Pin 18 and GND ₂ for proper regulation of the 2.5 V output of the internal LDO.
13	D _{OUT2-}	Inverted Differential Output 2.
14	D _{OUT2+}	Noninverted Differential Output 2.
15	D _{IN1-}	Inverted Differential Input 1.
16	D _{IN1+}	Noninverted Differential Input 1.
20	V _{IN2}	Optional 3.3 V Power Supply/LDO Input for Side 2. Bypass V _{IN2} to GND ₂ using a 1 μ F capacitor. Alternatively, if using a 2.5 V supply, connect V _{IN2} directly to V _{DD2} .

TYPICAL PERFORMANCE CHARACTERISTICS

$V_{DD1} = V_{DD2} = 2.5\text{ V}$, $T_A = 25^\circ\text{C}$, $R_L = 100\ \Omega$, 300 MHz input with $|V_{ID}| = 200\text{ mV}$, and $V_{IC} = 1.1\text{ V}$, unless otherwise noted.

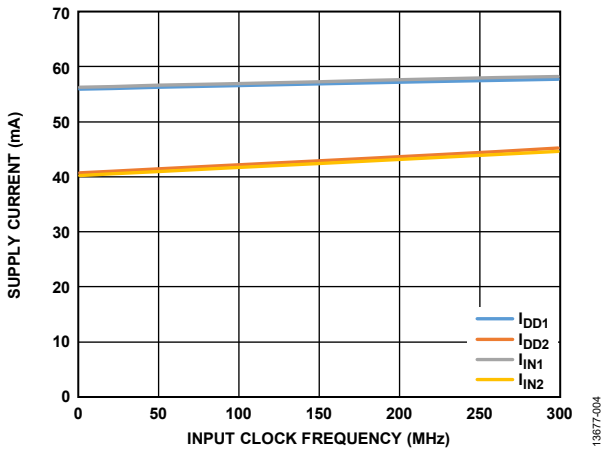

Figure 9. I_{DD1}/I_{DD2} or I_{IN1}/I_{IN2} Supply Current vs. $D_{IN1\pm}$ Input Clock Frequency ($D_{IN2\pm}$ Not Switching)

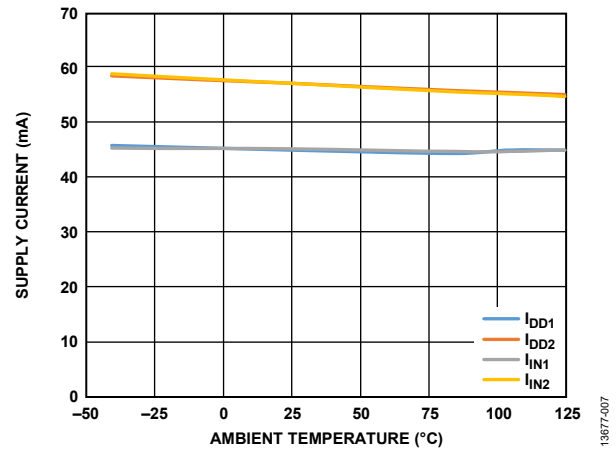

Figure 12. I_{DD1}/I_{DD2} or I_{IN1}/I_{IN2} Supply Current vs. Ambient Temperature (T_A) ($D_{IN2\pm}$ with 300 MHz Clock Input, $D_{IN1\pm}$ Not Switching)

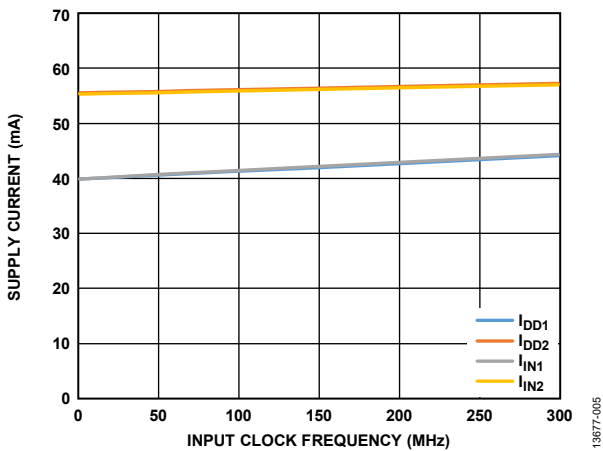

Figure 10. I_{DD1}/I_{DD2} or I_{IN1}/I_{IN2} Supply Current vs. $D_{IN2\pm}$ Input Clock Frequency ($D_{IN1\pm}$ Not Switching)

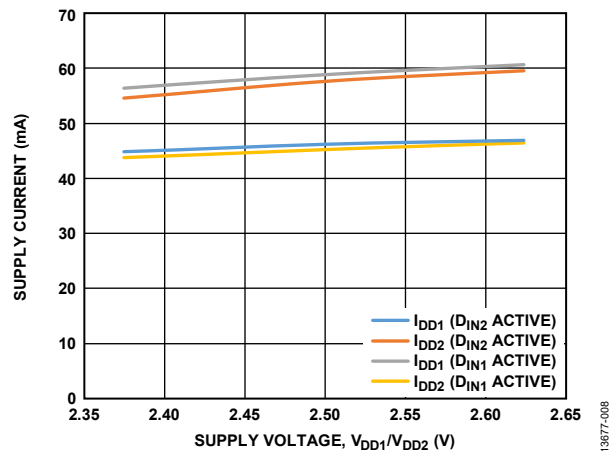

Figure 13. I_{DD1}/I_{DD2} Supply Current vs. Supply Voltage, V_{DD1}/V_{DD2}

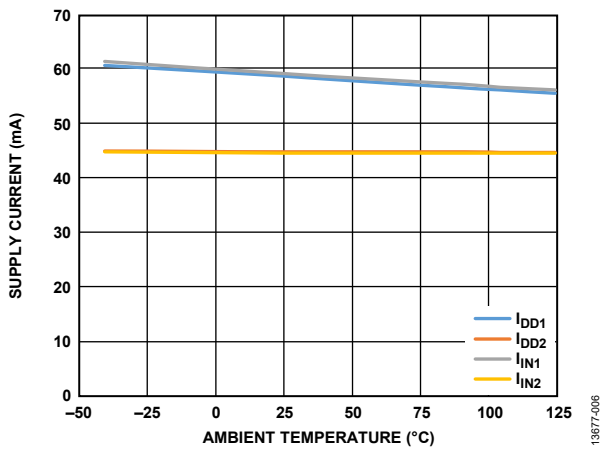

Figure 11. I_{DD1}/I_{DD2} or I_{IN1}/I_{IN2} Supply Current vs. Ambient Temperature (T_A) ($D_{IN1\pm}$ with 300 MHz Clock Input, $D_{IN2\pm}$ Not Switching)

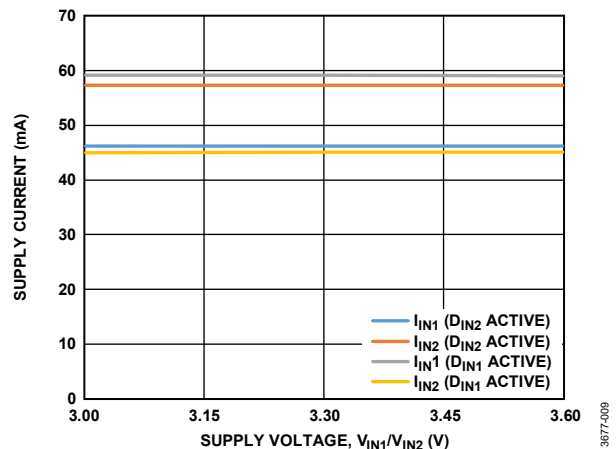

Figure 14. I_{IN1}/I_{IN2} Supply Current vs. Supply Voltage, V_{IN1}/V_{IN2}

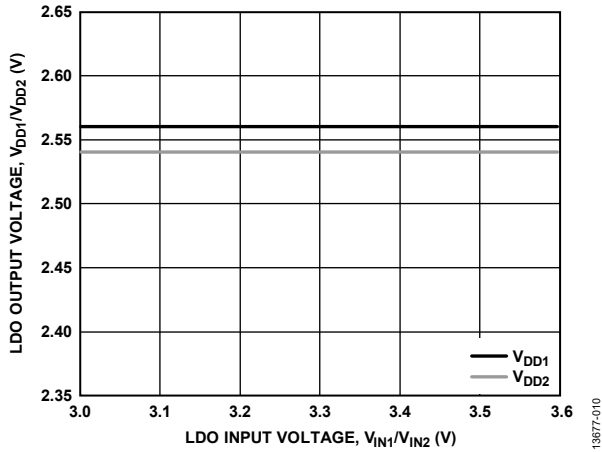

Figure 15. LDO Output Voltage, V_{DD1}/V_{DD2} vs. LDO Input Voltage, V_{IN1}/V_{IN2}

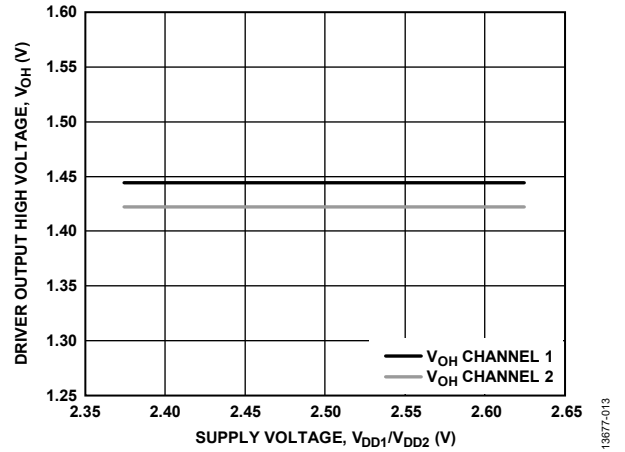

Figure 18. Driver Output High Voltage, V_{OH} vs. Supply Voltage, V_{DD1}/V_{DD2}

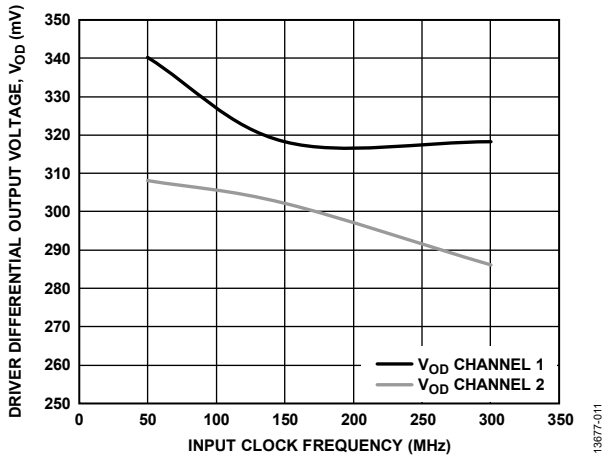

Figure 16. Driver Differential Output Voltage, V_{OD} vs. Input Clock Frequency

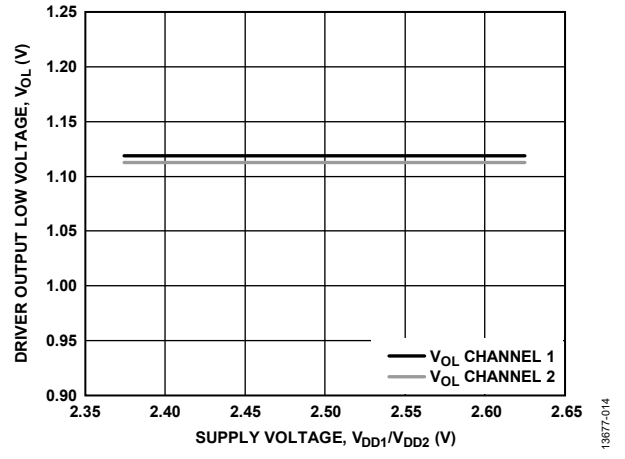

Figure 19. Driver Output Low Voltage, V_{OL} vs. Supply Voltage, V_{DD1}/V_{DD2}

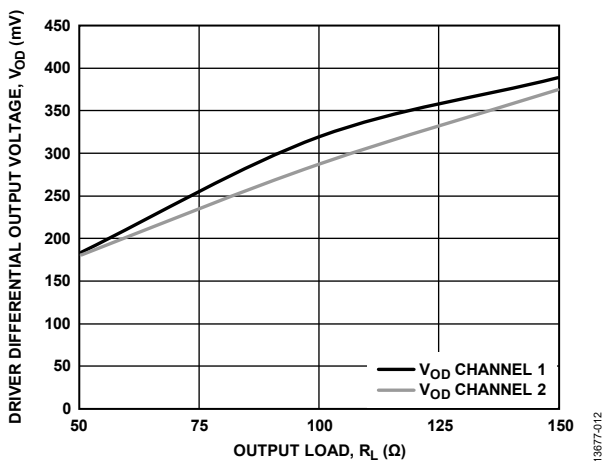

Figure 17. Driver Differential Output Voltage, V_{OD} vs. Output Load, R_L

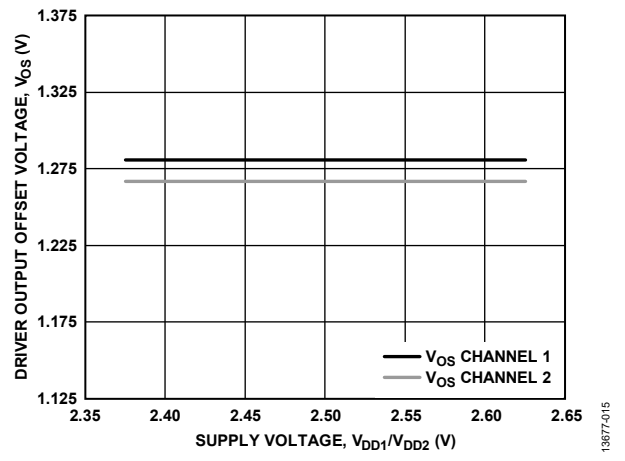

Figure 20. Driver Output Offset Voltage, V_{OS} vs. Supply Voltage, V_{DD1}/V_{DD2}

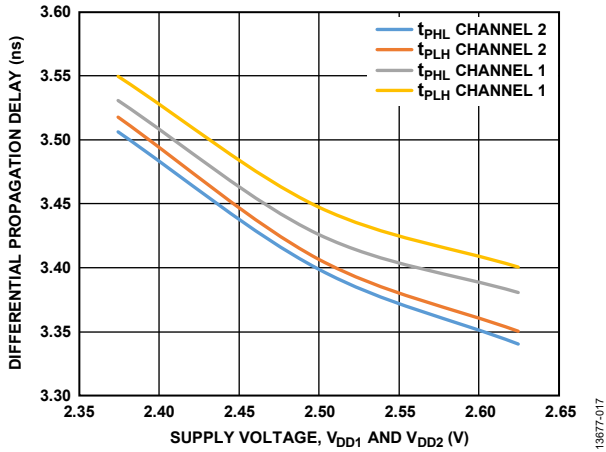

Figure 21. Differential Propagation Delay vs. Supply Voltage, V_{DD1} and V_{DD2}

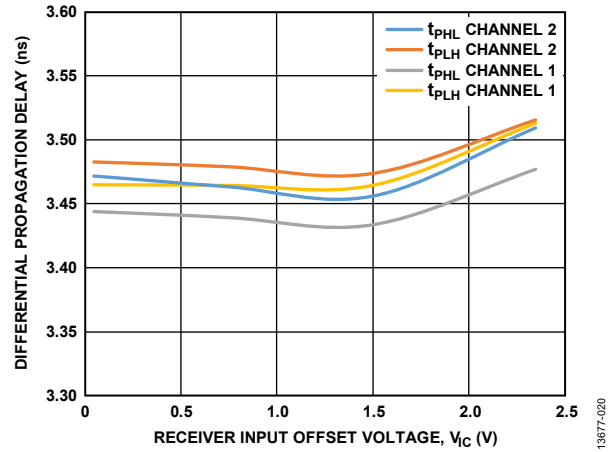

Figure 24. Differential Propagation Delay vs. Receiver Input Offset Voltage, V_{IC}

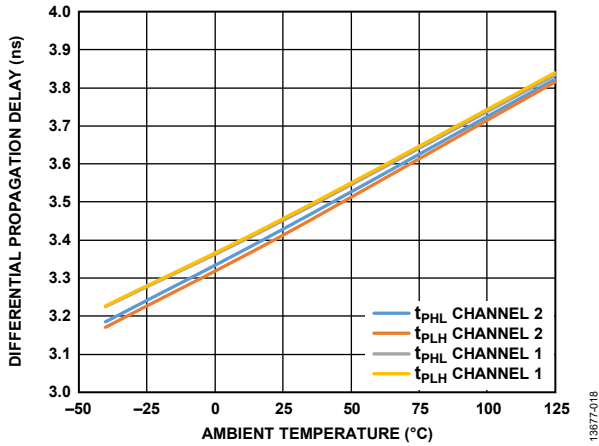

Figure 22. Differential Propagation Delay vs. Ambient Temperature (T_A)

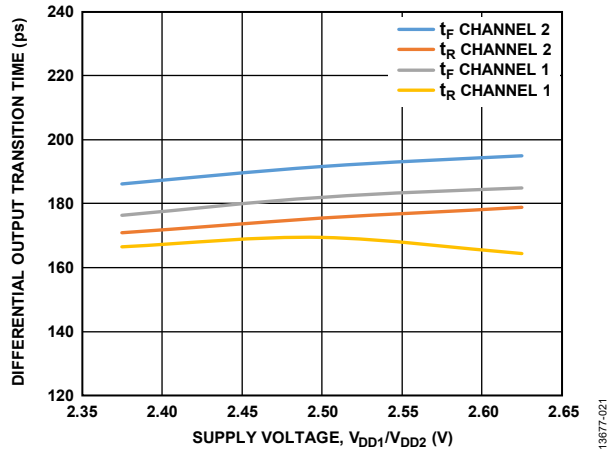

Figure 25. Differential Output Transition Time vs. Supply Voltage, V_{DD1}/V_{DD2}

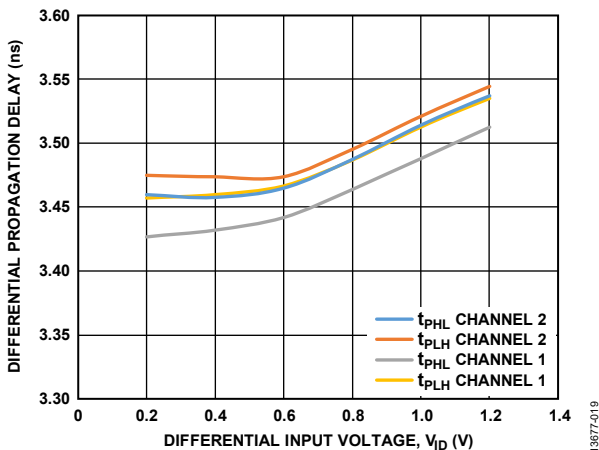

Figure 23. Differential Propagation Delay vs. Receiver Differential Input Voltage, V_{ID}

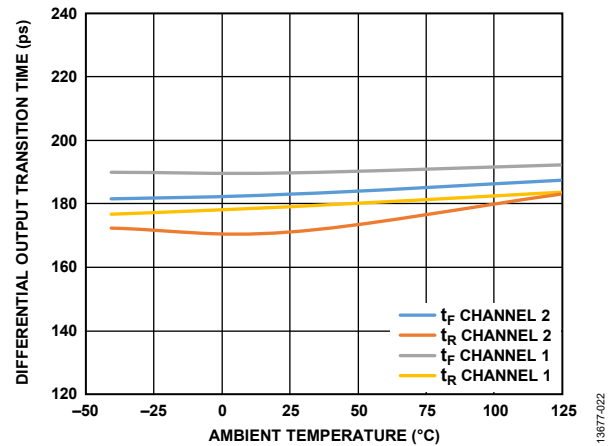

Figure 26. Differential Output Transition Time vs. Ambient Temperature (T_A)

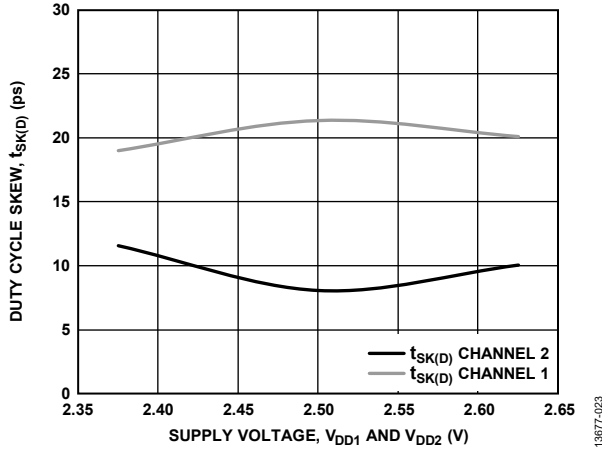

Figure 27. Duty Cycle Skew, $t_{SK(D)}$ vs. Supply Voltage, V_{DD1} AND V_{DD2}

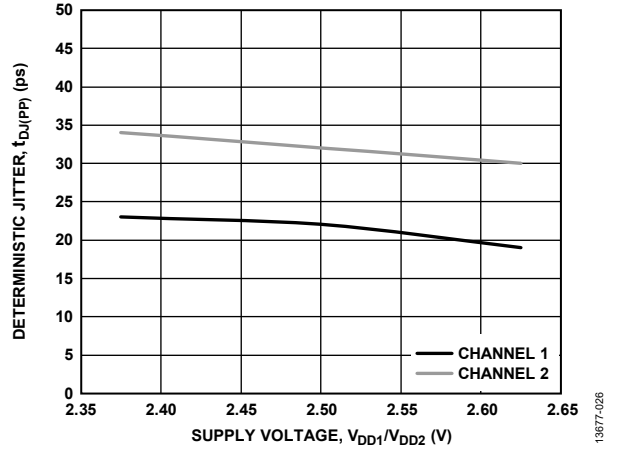

Figure 30. Deterministic Jitter, $t_{DJ(PP)}$ vs. Supply Voltage, V_{DD1}/V_{DD2}

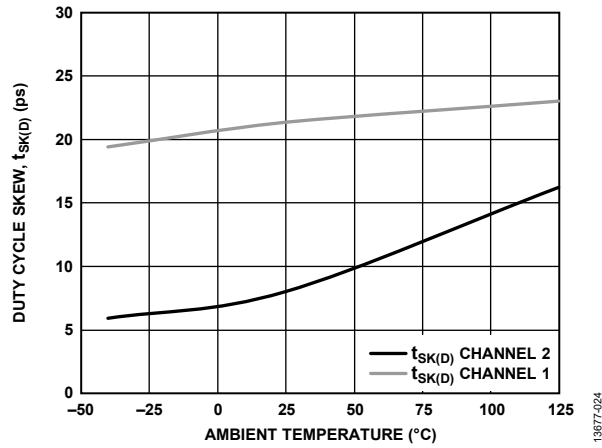

Figure 28. Duty Cycle Skew, $t_{SK(D)}$ vs. Ambient Temperature (T_A)

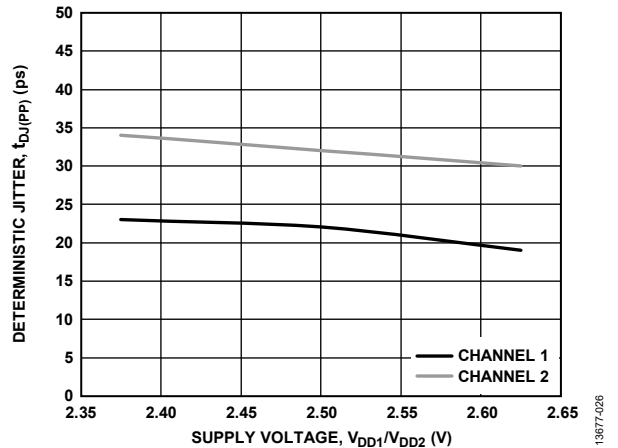

Figure 31. Deterministic Jitter, $t_{DJ(PP)}$ vs. Ambient Temperature

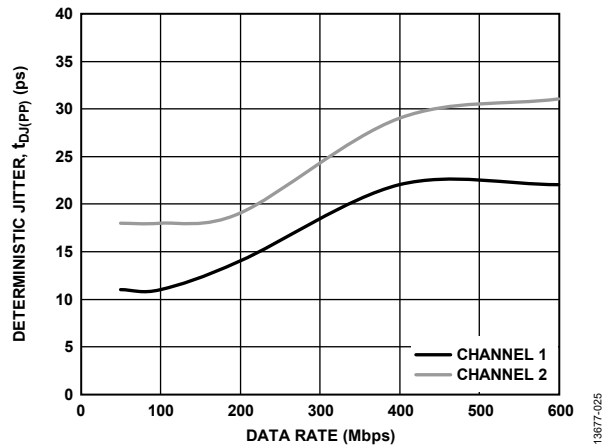

Figure 29. Deterministic Jitter, $t_{DJ(PP)}$ vs. Data Rate

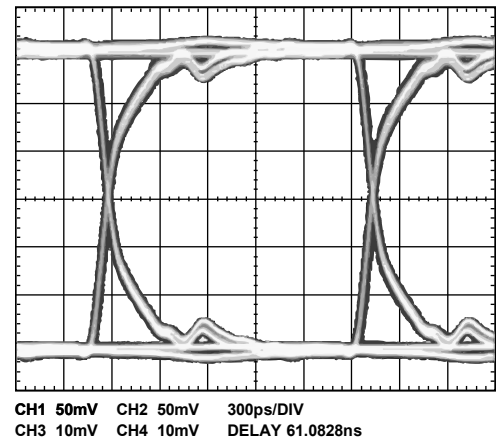
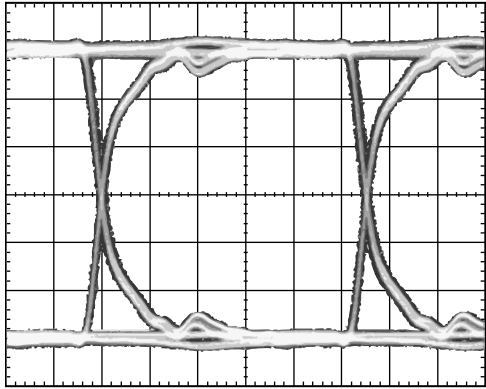

Figure 32. ADN4651 Eye Diagram for $D_{OUT1\pm}$



CH1 50mV CH2 50mV 300ps/DIV
CH3 10mV CH4 10mV DELAY 61.0828ns

13877-029

Figure 33. [ADN4651](#) Eye Diagram for $D_{OUT2\pm}$

TEST CIRCUITS AND SWITCHING CHARACTERISTICS

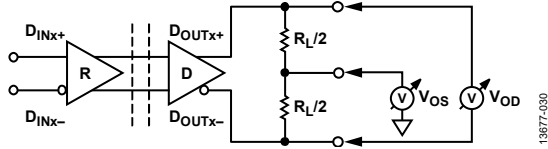
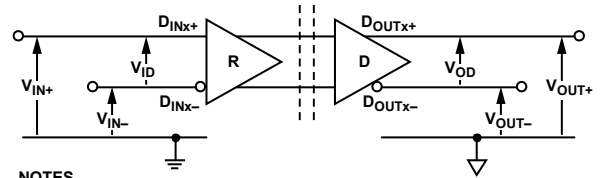

Figure 34. Driver Test Circuit

13677-030



- NOTES
1. $V_{ID} = V_{IN+} - V_{IN-}$
 2. $V_{IC} = (V_{IN+} + V_{IN-})/2$
 3. $V_{OD} = V_{OUT+} - V_{OUT-}$
 4. $V_{OS} = (V_{OUT+} + V_{OUT-})/2$

Figure 36. Voltage Definitions

13677-032

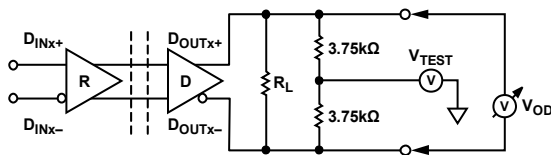

- NOTES
1. $V_{TEST} = 0V$ TO $2.4V$

Figure 35. Driver Test Circuit (Full Load Across Common-Mode Range)

13677-031

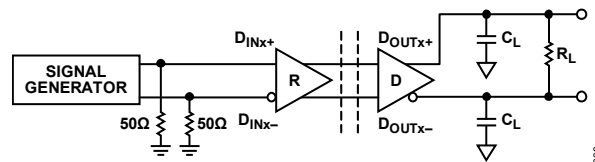

- NOTES
1. C_L INCLUDES PROBE AND JIG CAPACITANCE.

Figure 37. Timing Test Circuit

13677-033

THEORY OF OPERATION

The [ADN4650/ADN4651/ADN4652](#) are TIA/EIA-644-A LVDS compliant isolated buffers. LVDS signals applied to the inputs are transmitted on the outputs of the buffer, and galvanic isolation is integrated between the two sides of the device. This integration allows drop-in isolation of LVDS signal chains.

The LVDS receiver detects the differential voltage present across a termination resistor on an LVDS input. An integrated digital isolator transmits the input state across the isolation barrier, and an LVDS driver outputs the same state as the input.

With a positive differential voltage of ≥ 100 mV across any $D_{INx\pm}$ pin, the corresponding D_{OUTx+} pin sources current. This current flows across the connected transmission line and termination at the receiver at the far end of the bus, while D_{OUTx-} sinks the return current. With a negative differential voltage of ≤ -100 mV across any $D_{INx\pm}$ pin, the corresponding D_{OUTx+} pin sinks current, with D_{OUTx-} sourcing the current. Table 16 and Table 17 show these input/output combinations.

The output drive current is between ± 2.5 mA and ± 4.5 mA (typically ± 3.1 mA), developing between ± 250 mV and ± 450 mV across a 100Ω termination resistor (R_T). The received voltage is centered around 1.2 V. Note that because the differential voltage (V_{ID}) reverses polarity, the peak-to-peak voltage swing across R_T is twice the differential voltage magnitude ($|V_{ID}|$).

TRUTH TABLE AND FAIL-SAFE RECEIVER

The LVDS standard, TIA/EIA-644-A, defines normal receiver operation under two conditions: an input differential voltage of $\geq +100$ mV corresponding to one logic state, and a voltage of ≤ -100 mV for the other logic state. Between these thresholds, standard LVDS receiver operation is undefined (it may detect either state), as shown in Table 16 for the [ADN4650](#). The [ADN4651/ADN4652](#) incorporate a fail-safe circuit to ensure

the LVDS outputs are in a known state (logic high) when the input state is undefined ($-100 \text{ mV} < V_{ID} < +100 \text{ mV}$), as shown in Table 17.

This input state can occur when the inputs are floating (unconnected, no termination resistor), when the inputs are shorted, and when there is no active driver connected to the inputs (but with a termination resistor). Open-circuit, short-circuit, and terminated/idle bus fail-safes, respectively, ensure a known output state for these conditions, as implemented by the [ADN4651/ADN4652](#).

After the fail-safe circuit is triggered by these input states ($-100 \text{ mV} < V_{ID} < +100 \text{ mV}$), there is a delay of up to $1.2 \mu\text{s}$ before the output is guaranteed to be high ($V_{OD} \geq 250 \text{ mV}$). During this time, the output may transition to or stay in a logic low state ($V_{OD} \leq -250 \text{ mV}$).

The fail-safe circuit triggers as soon as the input differential voltage remains between $+100$ mV and -100 mV for some nanoseconds. This means that very slow rise and fall times on the input signal, outside typical LVDS operation (350 ps maximum t_R/t_F), can potentially trigger the fail-safe circuit on a high to low crossover.

At the minimum $|V_{ID}|$ of 100 mV for normal operation, the rise/fall time must be $\leq 5 \text{ ns}$ to avoid triggering a fail-safe state. Increasing $|V_{ID}|$ to 200 mV correspondingly allows an input rise/fall time of up to 10 ns without triggering a fail-safe state. For very low speed applications where slow high to low transitions in excess of this limit are expected, using external biasing resistors is an option to introduce a minimum $|V_{ID}|$ of 100 mV (that is, the fail-safe cannot trigger).

Table 16. [ADN4650](#) Input/Output Operation

Input ($D_{INx\pm}$)			Output ($D_{OUTx\pm}$)		
Powered On	V_{ID} (mV)	Logic	Powered On	V_{OD} (mV)	Logic
Yes	≥ 100	High	Yes	≥ 250	High
Yes	≤ -100	Low	Yes	≤ -250	Low
Yes	$-100 < V_{ID} < +100$	Indeterminate	Yes	Indeterminate	Indeterminate
No	Don't care	Don't care	Yes	≥ 250	High

Table 17. [ADN4651/ADN4652](#) Input/Output Operation

Input ($D_{INx\pm}$)			Output ($D_{OUTx\pm}$)		
Powered On	V_{ID} (mV)	Logic	Powered On	V_{OD} (mV)	Logic
Yes	≥ 100	High	Yes	≥ 250	High
Yes	≤ -100	Low	Yes	≤ -250	Low
Yes	$-100 < V_{ID} < +100$	Indeterminate	Yes	≥ 250	High
No	Don't care	Don't care	Yes	≥ 250	High

ISOLATION

In response to any change in the input state detected by the integrated LVDS receiver, an encoder circuit sends narrow (~1 ns) pulses to a decoder circuit using integrated transformer coils. The decoder is bistable and is, therefore, either set or reset by the pulses that indicate input transitions. The decoder state determines the LVDS driver output state in normal operation, and this in turn reflects the isolated LVDS buffer input state.

In the absence of input transitions for more than approximately 1 μ s, a periodic set of refresh pulses, indicative of the correct input state, ensures dc correctness at the output (including the fail-safe output state, if applicable). These periodic refresh pulses also correct the output state within 1 μ s in the event of a fault condition or set the ADN4651/ADN4652 output to the fail-safe state.

On power-up, the output state may initially be in the incorrect dc state if there are no input transitions. The output state is corrected within 1 μ s by the refresh pulses.

If the decoder receives no internal pulses for more than approximately 1 μ s, the device assumes that the input side is unpowered or nonfunctional, in which case, the output is set to a positive differential voltage (logic high).

PCB LAYOUT

The ADN4650/ADN4651/ADN4652 can operate with high speed LVDS signals up to 300 MHz clock, or 600 Mbps nonreturn to zero (NRZ) data. With such high frequencies, it is particularly important to apply best practices for the LVDS trace layout and termination. Locate a 100 Ω termination resistor as close as possible to the receiver, across the D_{INx+} and D_{INx-} pins.

Controlled 50 Ω impedance traces are needed on the LVDS signal lines for full signal integrity, reduced system jitter, and minimizing electromagnetic interference (EMI) from the PCB. Trace widths, lateral distance within each pair, and distance to the ground plane underneath all must be chosen appropriately. Via fencing to the PCB ground between pairs is also a best practice to minimize crosstalk between adjacent pairs.

The ADN4650/ADN4651/ADN4652 pass EN55022 Class B emissions limits without extra considerations required for the isolator when operating with up to 600 Mbps PRBS data. When isolating high speed clocks (for example, 300 MHz), a reduced PCB clearance (isolation gap) may be required with the 20-lead SOIC models to reduce dipole antenna effects and provide sufficient margin below Class B emissions limits. The 20-lead SSOP models pass the Class B limits up to 150 MHz clock frequencies with no extra PCB measures.

The best practice for high speed PCB design avoids any other emissions from PCBs in applications that use the ADN4650/ADN4651/ADN4652. Special care is recommended for off board connections, where switching transients from high speed LVDS signals (and clocks in particular) may conduct onto cabling, resulting in radiated emissions. Use common-mode chokes, ferrites, or other filters as appropriate at the LVDS connectors, as well as cable shield or PCB ground connections to earth/chassis.

The ADN4650/ADN4651/ADN4652 require appropriate decoupling of the V_{DDx} pins with 100 nF capacitors. If the integrated LDO is not used, and a 2.5 V supply is connected directly, connect the appropriate V_{INx} pin to the supply as well, as shown in Figure 38, using the ADN4651 as an example.

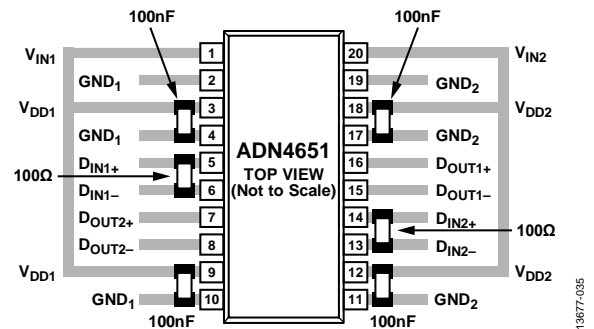

Figure 38. Required PCB Layout When Not Using the LDO (2.5 V Supply)

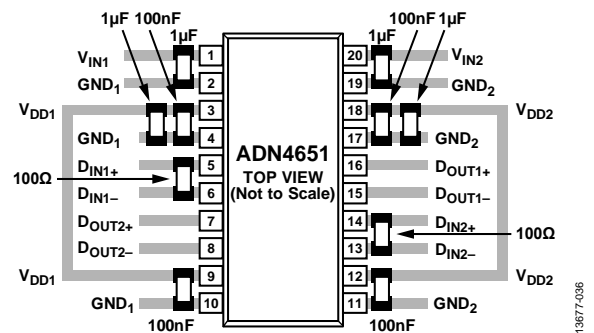

Figure 39. Required PCB Layout When Using the LDO (3.3 V Supply)

When the integrated LDO is used, bypass capacitors of 1 μ F are required on the V_{INx} pins and on the nearest V_{DDx} pins (LDO output), as shown in Figure 39, using the ADN4651 as an example.

MAGNETIC FIELD IMMUNITY

The limitation on the magnetic field immunity of the device is set by the condition in which the induced voltage in the transformer receiving coil is sufficiently large, either to falsely set or reset the decoder. The following analysis defines such conditions. The ADN4650/ADN4651/ADN4652 are examined in a 2.375 V operating condition because it represents the most susceptible mode of operation for this product.

The pulses at the transformer output have an amplitude greater than 0.5 V. The decoder has a sensing threshold of about 0.25 V, therefore establishing a 0.25 V margin in which induced voltages are tolerated. The voltage induced across the receiving coil is given by the following:

$$V = (-d\beta/dt)\Sigma\pi r_n^2; n = 1, 2, \dots, N$$

where:

β is the magnetic flux density.

r_n is the radius of the n^{th} turn in the receiving coil.

N is the number of turns in the receiving coil.

Given the geometry of the receiving coil in the [ADN4650/ADN4651/ADN4652](#), and an imposed requirement that the induced voltage be, at most, 50% of the 0.25 V margin at the decoder, a maximum allowable magnetic field is calculated as shown in Figure 40.

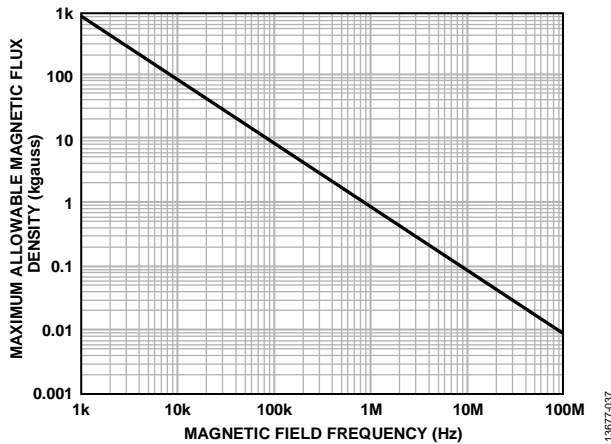

Figure 40. Maximum Allowable External Magnetic Flux Density

For example, at a magnetic field frequency of 1 MHz, the maximum allowable magnetic field of 0.92 kgauss induces a voltage of 0.125 V at the receiving coil. This voltage is about 50% of the sensing threshold and does not cause a faulty output transition. If such an event occurs with the worst case polarity during a transmitted pulse, it reduces the received pulse from >0.5 V to 0.375 V. This voltage is still higher than the 0.25 V sensing threshold of the decoder.

The preceding magnetic flux density values correspond to specific current magnitudes at given distances from the [ADN4650/ADN4651/ADN4652](#) transformers. Figure 41 expresses these allowable current magnitudes as a function of frequency for selected distances. The [ADN4650/ADN4651/ADN4652](#) are very insensitive to external fields. Only extremely large, high frequency currents, very close to the component, can potentially be a concern. For the 1 MHz example noted, a 2.29 kA current must be placed 5 mm from the [ADN4650/ADN4651/ADN4652](#) to affect component operation.

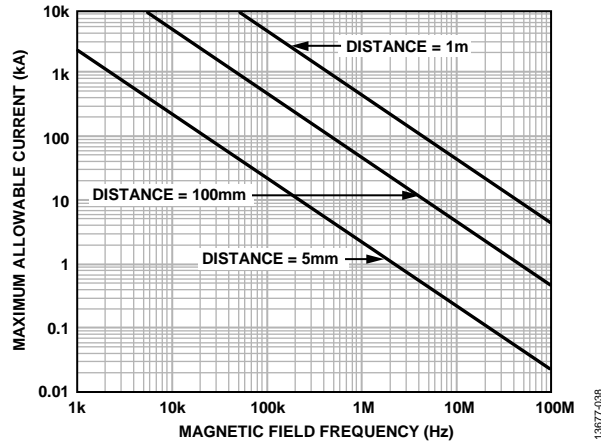

Figure 41. Maximum Allowable Current for Various Current to [ADN4650/ADN4651/ADN4652](#) Spacings

Note that at combinations of strong magnetic field and high frequency, any loops formed by PCB traces can induce sufficiently large error voltages to trigger the thresholds of succeeding circuitry. Avoid PCB structures that form loops.

INSULATION LIFETIME

All insulation structures eventually break down when subjected to voltage stress over a sufficiently long period. The rate of insulation degradation is dependent on the characteristics of the voltage waveform applied across the insulation as well as on the materials and material interfaces.

The two types of insulation degradation of primary interest are breakdown along surfaces exposed to the air and insulation wear out. Surface breakdown is the phenomenon of surface tracking and the primary determinant of surface creepage requirements in system level standards. Insulation wear out is the phenomenon where charge injection or displacement currents inside the insulation material cause long-term insulation degradation.

Surface Tracking

Surface tracking is addressed in electrical safety standards by setting a minimum surface creepage based on the working voltage, the environmental conditions, and the properties of the insulation material. Safety agencies perform characterization testing on the surface insulation of components that allows the components to be categorized in different material groups. Lower material group ratings are more resistant to surface tracking and, therefore, can provide adequate lifetime with smaller creepage. The minimum creepage for a given working voltage and material group is in each system level standard and is based on the total rms voltage across the isolation barrier, pollution degree, and material group. The material group and creepage for [ADN4650/ADN4651/ADN4652](#) are presented in Table 4 and Table 5.

Insulation Wear Out

The lifetime of insulation caused by wear out is determined by the thickness, material properties, and the voltage stress applied. It is important to verify that the product lifetime is adequate at the application working voltage. The working voltage supported by an isolator for wear out may not be the same as the working voltage supported for tracking. It is the working voltage applicable to tracking that is specified in most standards.

Testing and modeling show that the primary driver of long-term degradation is displacement current in the polyimide insulation causing incremental damage. The stress on the insulation can be broken down into broad categories, such as dc stress, which causes very little wear out because there is no displacement current, and an ac component time varying voltage stress, which causes wear out.

The ratings in certification documents are usually based on 60 Hz sinusoidal stress because this reflects isolation from line voltage. However, many practical applications have combinations of 60 Hz ac and dc across the isolation barrier, as shown in Equation 1. Because only the ac portion of the stress causes wear out, the equation can be rearranged to solve for the ac rms voltage, as shown in Equation 2. For insulation wear out with the polyimide materials used in this product, the ac rms voltage determines the product lifetime.

$$V_{RMS} = \sqrt{V_{AC\ RMS}^2 + V_{DC}^2} \quad (1)$$

or

$$V_{AC\ RMS} = \sqrt{V_{RMS}^2 - V_{DC}^2} \quad (2)$$

where:

V_{RMS} is the total rms working voltage.

$V_{AC\ RMS}$ is the time varying portion of the working voltage.

V_{DC} is the dc offset of the working voltage.

Calculation and Use of Parameters Example

The following example frequently arises in power conversion applications. Assume that the line voltage on one side of the isolation is 240 V ac rms and a 400 V dc bus voltage is present on the other side of the isolation barrier. The isolator material is polyimide. To establish the critical voltages in determining the creepage, clearance, and lifetime of a device, see Figure 42 and the following equations.

The working voltage across the barrier from Equation 1 is

$$V_{RMS} = \sqrt{V_{AC\ RMS}^2 + V_{DC}^2}$$

$$V_{RMS} = \sqrt{240^2 + 400^2}$$

$$V_{RMS} = 466\text{ V}$$

This V_{RMS} value is the working voltage used together with the material group and pollution degree when looking up the creepage required by a system standard.

To determine if the lifetime is adequate, obtain the time varying portion of the working voltage. To obtain the ac rms voltage, use Equation 2.

$$V_{AC\ RMS} = \sqrt{V_{RMS}^2 - V_{DC}^2}$$

$$V_{AC\ RMS} = \sqrt{466^2 - 400^2}$$

$$V_{AC\ RMS} = 240\text{ V rms}$$

In this case, the ac rms voltage is simply the line voltage of 240 V rms. This calculation is more relevant when the waveform is not sinusoidal. The value is compared to the limits for the working voltage in Table 12 for the expected lifetime, less than a 60 Hz sine wave, and it is well within the limit for a 50-year service life.

Note that the dc working voltage limit in Table 12 is set by the creepage of the package as specified in IEC 60664-1. This value can differ for specific system level standards.

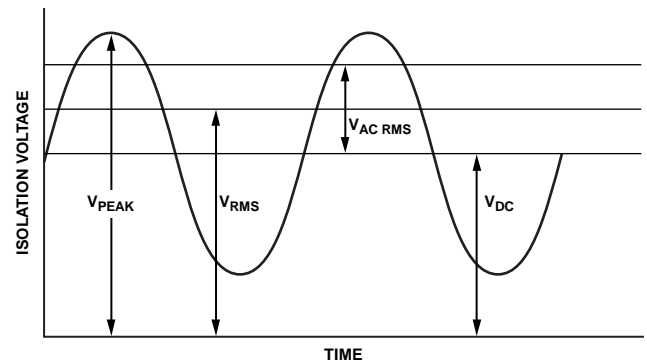

Figure 42. Critical Voltage Example

13877-039

APPLICATIONS INFORMATION

High speed LVDS interfaces can be isolated using the [ADN4650/ADN4651/ADN4652](#) either between components, between boards, or at a cable interface. The [ADN4650/ADN4651/ADN4652](#) offer full LVDS compliant inputs and outputs, allowing increased LVDS output drive strength compared to built-in reduced specification LVDS interfaces on other components. The LVDS compliant receiver inputs on the [ADN4650/ADN4651/ADN4652](#) also ensure full compatibility with any LVDS source being isolated.

Isolated analog front-end applications provide an example of the [ADN4650/ADN4651](#) isolating an LVDS interface between components. As shown in Figure 43, two [ADN4650](#) components isolate the LVDS interface of the [AD7960](#) analog-to-digital converter (ADC), including 600 Mbps data, a 300 MHz echoed clock, and a 5 MHz sample clock. Isolation of the [AD7960](#) using two [ADN4651](#) components is shown in Figure 44. The [ADN4651](#) additive phase jitter is sufficiently low that it does not affect the ADC performance even when isolating the sample clock. In addition, implementing the galvanic isolation improves ADC performance by removing digital and power supply noise from the field-programmable gate array (FPGA) circuit.

Newer programmable logic controller (PLC) and input/output modules communicate across an LVDS backplane, illustrating a board to board LVDS interface, as shown in Figure 45. With a daisy-chain type topology for transmit and receive to either adjacent node, two [ADN4651](#) (or [ADN4652](#)) devices on each node can isolate four LVDS channels. The addition of galvanic isolation allows a much more robust backplane interface port on the PLC or input/output modules.

With galvanic isolation, even LVDS ports can be treated as full external ports and transmitted along cable runs (see Figure 46), even in harsh environments where high common-mode voltages may be induced on the cable. The low jitter of the [ADN4651/ADN4652](#) ensures that more of the jitter budget can be used to account for the cable effects, allowing the cable to be as long as possible. The [ADN4651/ADN4652](#) offer a high drive strength, fully LVDS compliant output, capable of driving short cable runs of a few meters. This is in contrast to alternative isolation methods that degrade the LVDS signal quality. The data rate can be chosen as appropriate for the cable length; the [ADN4651/ADN4652](#) operate not only at 600 Mbps but also at any arbitrary data rate down to dc.

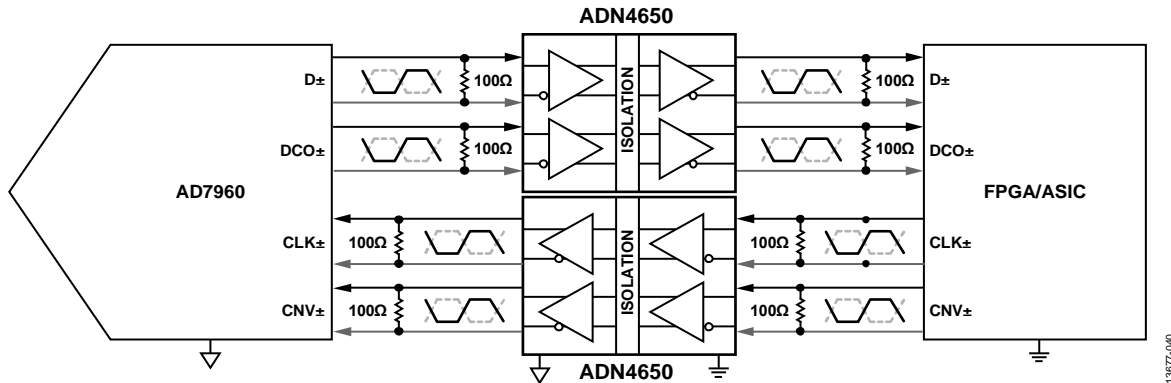

Figure 43. Example Isolated Analog Front-End Implementation (Isolated [AD7960](#) Using the [ADN4650](#))

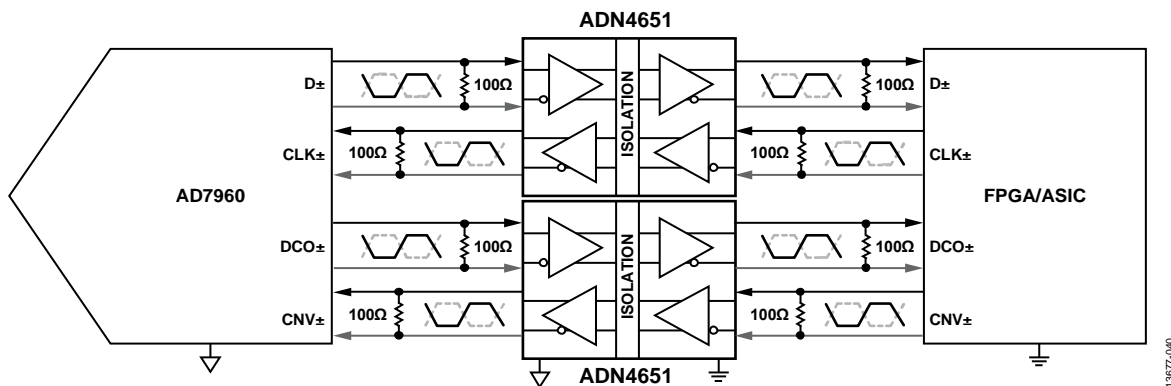

Figure 44. Example Isolated Analog Front-End Implementation (Isolated [AD7960](#) Using the [ADN4651](#))

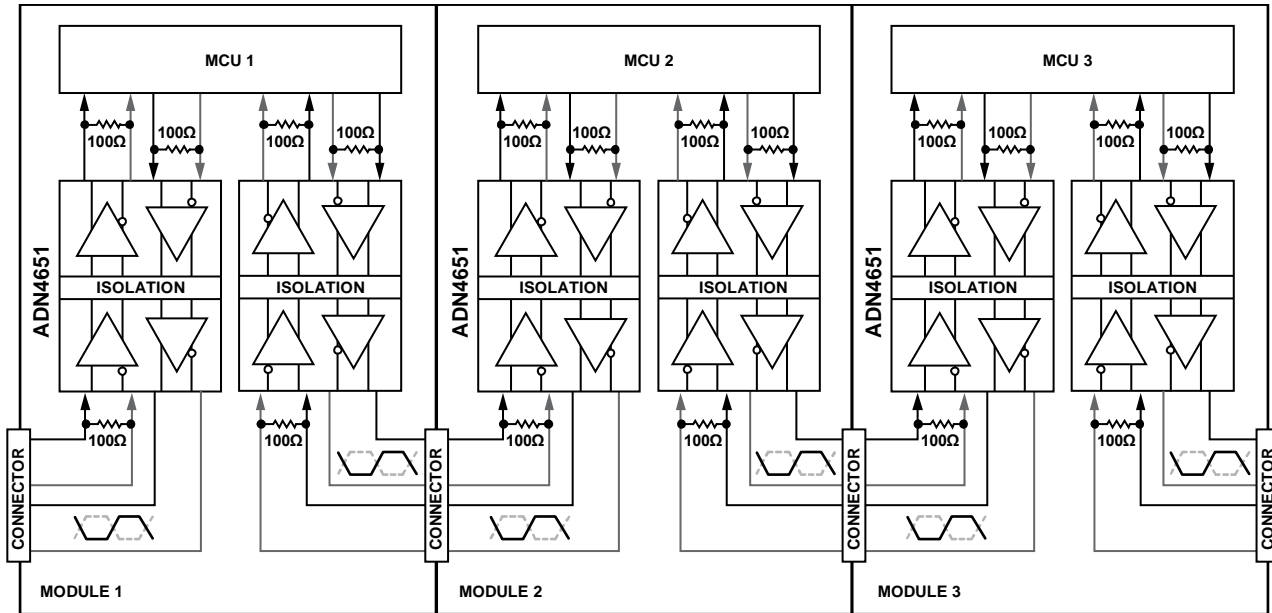

Figure 45. Example Isolated Backplane Implementation for PLCs and Input/Output Modules Using the [ADN4651](#)

13877-041

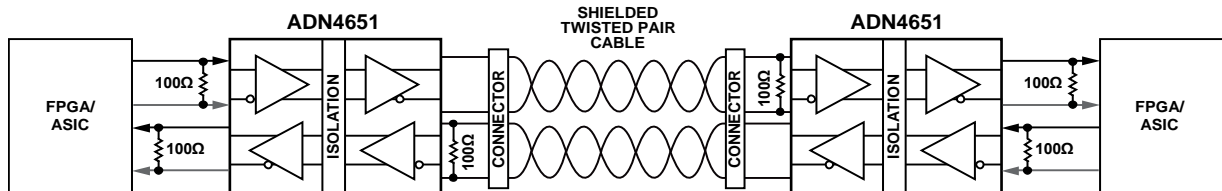
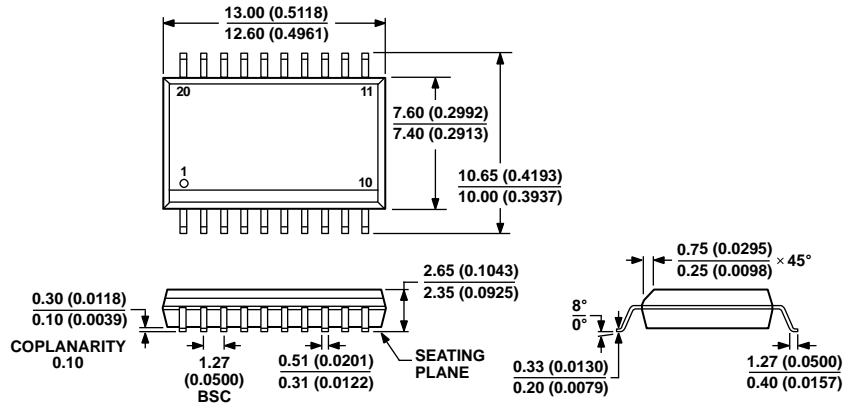

Figure 46. Example Isolated LVDS Cable Application Using the [ADN4651](#)

13877-042

OUTLINE DIMENSIONS



COMPLIANT TO JEDEC STANDARDS MS-013-AC
 CONTROLLING DIMENSIONS ARE IN MILLIMETERS; INCH DIMENSIONS
 (IN PARENTHESES) ARE ROUNDED-OFF MILLIMETER EQUIVALENTS FOR
 REFERENCE ONLY AND ARE NOT APPROPRIATE FOR USE IN DESIGN.

Figure 47. 20-Lead Standard Small Outline Package [SOIC_W]
 Wide Body
 (RW-20)
 Dimensions shown in millimeters and (inches)

06-07-2006-A

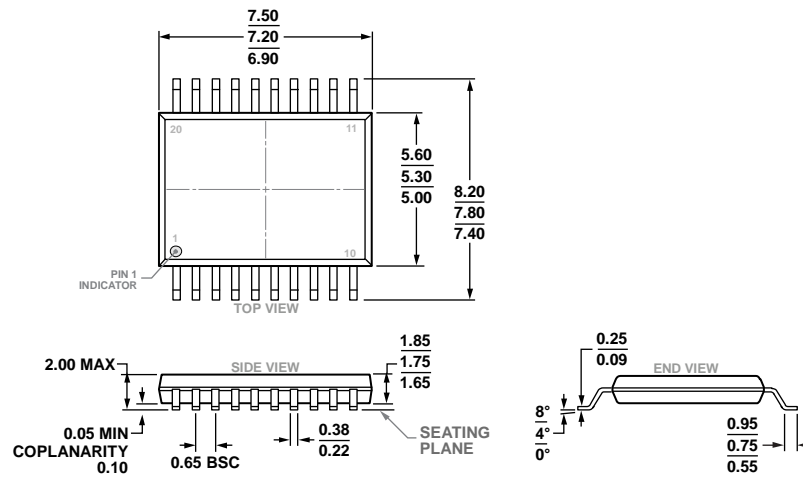

COMPLIANT TO JEDEC STANDARDS MO-150-AE

Figure 48. 20-Lead Shrink Small Outline Package [SSOP]
 (RS-20)
 Dimensions shown in millimeters

06-01-2006-A

ORDERING GUIDE

Model ¹	Temperature Range	Package Description	Package Option
ADN4650BRWZ	-40°C to +125°C	20-Lead, Wide Body, Standard Small Outline Package [SOIC_W]	RW-20
ADN4650BRWZ-RL7	-40°C to +125°C	20-Lead, Wide Body, Standard Small Outline Package [SOIC_W]	RW-20
ADN4650BRSZ	-40°C to +125°C	20-Lead Shrink Small Outline Package [SSOP]	RS-20
ADN4650BRSZ-RL7	-40°C to +125°C	20-Lead Shrink Small Outline Package [SSOP]	RS-20

Model ¹	Temperature Range	Package Description	Package Option
ADN4651BRSZ	-40°C to +125°C	20-Lead Shrink Small Outline Package [SSOP]	RS-20
ADN4651BRSZ-RL7	-40°C to +125°C	20-Lead Shrink Small Outline Package [SSOP]	RS-20
ADN4651BRWZ	-40°C to +125°C	20-Lead, Wide Body, Standard Small Outline Package [SOIC_W]	RW-20
ADN4651BRWZ-RL7	-40°C to +125°C	20-Lead, Wide Body, Standard Small Outline Package [SOIC_W]	RW-20
ADN4652BRSZ	-40°C to +125°C	20-Lead Shrink Small Outline Package [SSOP]	RS-20
ADN4652BRSZ-RL7	-40°C to +125°C	20-Lead Shrink Small Outline Package [SSOP]	RS-20
ADN4652BRWZ	-40°C to +125°C	20-Lead, Wide Body, Standard Small Outline Package [SOIC_W]	RW-20
ADN4652BRWZ-RL7	-40°C to +125°C	20-Lead, Wide Body, Standard Small Outline Package [SOIC_W]	RW-20
EVAL-ADN4650EBZ		ADN4650 SSOP Evaluation Board	
EVAL-ADN4650EB1Z		ADN4650 SOIC_W Evaluation Board	
EVAL-ADN4651EBZ		ADN4651 SSOP Evaluation Board	
EVAL-ADN4651EB1Z		ADN4651 SOIC_W Evaluation Board	
EVAL-ADN4652EBZ		ADN4652 SSOP Evaluation Board	
EVAL-ADN4652EB1Z		ADN4652 SOIC_W Evaluation Board	

¹Z = RoHS Compliant Part.

Looking for pricing, stock, or lifecycle information?

Click below to explore more details on WIN SOURCE:

- ⊖ [View ADN4650BRWZ-RL7 on WIN SOURCE](#)
- ⊖ [Analog Devices Inc. Information](#)

Optimize Your Supply Chain with WIN SOURCE Solutions

- ✓ Global Sourcing Solution
- ✓ Obsolete Management
- ✓ Cost Control Management
- ✓ Shortage Management
- ✓ Alternative Solution
- ✓ Excess Inventory Management