



**THE DATASHEET OF
ADIS16006CCCZ**



FEATURES

- Dual-axis accelerometer
- SPI digital output interface
- Internal temperature sensor
- Highly integrated; minimal external components
- Bandwidth externally selectable
- 1.9 mg resolution at 60 Hz
- Externally controlled electrostatic self-test
- 3.0 V to 5.25 V single-supply operation
- Low power: <2 mA
- 3500 g shock survival
- 7.2 mm × 7.2 mm × 3.7 mm package

APPLICATIONS

- Industrial vibration/motion sensing
- Platform stabilization
- Dual-axis tilt sensing
- Tracking, recording, analysis devices
- Alarms and security devices

GENERAL DESCRIPTION

The **ADIS16006** is a low cost, low power, complete dual-axis accelerometer with an integrated serial peripheral interface (SPI). An integrated temperature sensor is also available on the SPI interface. The **ADIS16006** measures acceleration with a full-scale range of $\pm 5\text{ g}$ (minimum). The **ADIS16006** can measure both dynamic acceleration (vibration) and static acceleration (gravity).

The typical noise floor is $200\ \mu\text{g}/\sqrt{\text{Hz}}$, allowing signals below 1.9 mg (60 Hz bandwidth) to be resolved.

The bandwidth of the accelerometer is set with optional capacitors, C_X and C_Y , at the XFILT pin and the YFILT pin. Digital output data for both axes is available via the serial interface.

An externally driven self-test pin (ST) allows the user to verify the accelerometer functionality.

The **ADIS16006** is available in a 7.2 mm × 7.2 mm × 3.7 mm, 12-terminal LGA package.

FUNCTIONAL BLOCK DIAGRAM

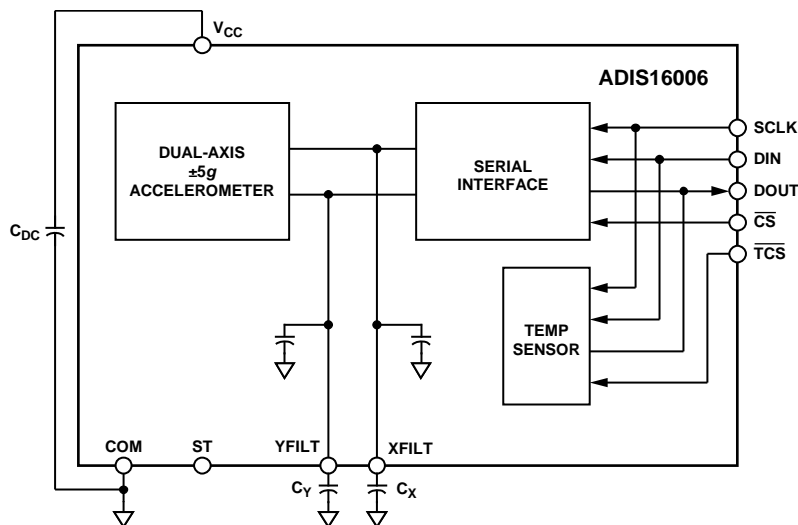

Figure 1.

058745-001

Rev. C

[Document Feedback](#)

Information furnished by Analog Devices is believed to be accurate and reliable. However, no responsibility is assumed by Analog Devices for its use, nor for any infringements of patents or other rights of third parties that may result from its use. Specifications subject to change without notice. No license is granted by implication or otherwise under any patent or patent rights of Analog Devices. Trademarks and registered trademarks are the property of their respective owners.

One Technology Way, P.O. Box 9106, Norwood, MA 02062-9106, U.S.A.
 Tel: 781.329.4700 ©2006–2013 Analog Devices, Inc. All rights reserved.
[Technical Support](#) www.analog.com

TABLE OF CONTENTS

Features	1	Accelerometer Data Format.....	11
Applications.....	1	Self-Test	11
General Description	1	Serial Interface	11
Functional Block Diagram	1	Accelerometer Serial Interface.....	11
Revision History	2	Temperature Sensor Serial Interface.....	12
Specifications.....	3	Power Supply Decoupling	12
Timing Specifications	4	Setting the Bandwidth	13
Circuit and Timing Diagrams.....	5	Selecting Filter Characteristics: The Noise/Bandwidth Trade-Off.....	13
Absolute Maximum Ratings.....	6	Applications.....	15
ESD Caution.....	6	Second Level Assembly.....	15
Pin Configuration and Function Descriptions.....	7	Outline Dimensions	16
Typical Performance Characteristics	8	Ordering Guide	16
Theory of Operation	11		

REVISION HISTORY

2/13—Rev. B to Rev. C	
Changes to Figure 23	14
3/12—Rev. A to Rev. B	
Added Accelerometer Data Format Section	11
Added Table 6; Renumbered Sequentially	11
10/07—Rev. 0 to Rev. A	
Changes to Features and General Description	1
Added Note 6 to Table 2	4
Changes to Figure 5.....	6
Changes to Accelerometer Control Register Section.....	11
Changes to Layout	13
Changes to Layout	14
Deleted Figure 24 and Table 11.....	14
Edited Second-Level Assembly Section.....	15
Updated Outline Dimensions	16
Changes to Ordering Guide	16
3/06—Revision 0: Initial Version	

SPECIFICATIONS

$T_A = -40^{\circ}\text{C}$ to $+125^{\circ}\text{C}$, $V_{CC} = 5\text{ V}$, $C_X = C_Y = 0\ \mu\text{F}$, acceleration = 0 g , unless otherwise noted. All minimum and maximum specifications are guaranteed. Typical specifications are not guaranteed.

Table 1.

Parameter	Conditions	Min	Typ	Max	Unit
ACCELEROMETER SENSOR INPUT	Each axis				
Measurement Range ¹		± 5			<i>g</i>
Nonlinearity	% of full scale		± 0.5	± 2.5	%
Package Alignment Error			± 1.5		Degrees
Alignment Error	X sensor to Y sensor		± 0.1		Degrees
Cross-Axis Sensitivity			± 1.5	± 3	%
ACCELEROMETER SENSITIVITY	Each axis				
Sensitivity at XFILT, YFILT		242	256	272	LSB/ <i>g</i>
Sensitivity Change due to Temperature ²	Delta from 25°C		± 0.3		%
ZERO <i>g</i> BIAS LEVEL	Each axis				
0 <i>g</i> Voltage at XFILT, YFILT		1905	2048	2190	LSB
0 <i>g</i> Offset vs. Temperature			± 0.1		LSB/°C
ACCELEROMETER NOISE PERFORMANCE					
Noise Density	At 25°C		200		$\mu\text{g}/\sqrt{\text{Hz}}$ rms
ACCELEROMETER FREQUENCY RESPONSE ^{3, 4}					
C_X, C_Y Range		0		10	μF
R_{FILT} Tolerance		24	32	40	k Ω
Sensor Bandwidth	$C_X = 0\ \mu\text{F}, C_Y = 0\ \mu\text{F}$		2.26		kHz
Sensor Resonant Frequency			5.5		kHz
ACCELEROMETER SELF-TEST					
Logic Input Low				$0.2 \times V_{CC}$	V
Logic Input High		$0.8 \times V_{CC}$			V
ST Input Resistance to COM		30	50		k Ω
Output Change at $X_{\text{OUT}}, Y_{\text{OUT}}$ ⁵	Self-Test 0 to Self-Test 1	102	205	307	LSB
TEMPERATURE SENSOR					
Accuracy	$V_{CC} = 3\text{ V to }5.25\text{ V}$		± 2		°C
Resolution			10		Bits
Update Rate			400		μs
Temperature Conversion Time			25		μs
DIGITAL INPUT					
Input High Voltage (V_{INH})	$V_{CC} = 4.75\text{ V to }5.25\text{ V}$	2.4			V
	$V_{CC} = 3.0\text{ V to }3.6\text{ V}$	2.1			V
Input Low Voltage (V_{INL})	$V_{CC} = 3.0\text{ V to }5.25\text{ V}$			0.8	V
Input Current	$V_{\text{IN}} = 0\text{ V or }V_{CC}$	-10	+1	+10	μA
Input Capacitance			10		pF
DIGITAL OUTPUT					
Output High Voltage (V_{OH})	$I_{\text{SOURCE}} = 200\ \mu\text{A}, V_{CC} = 3.0\text{ V to }5.25\text{ V}$	$V_{CC} - 0.5$			V
Output Low Voltage (V_{OL})	$I_{\text{SINK}} = 200\ \mu\text{A}$			0.4	V

Parameter	Conditions	Min	Typ	Max	Unit
POWER SUPPLY					
Operating Voltage Range		3.0		5.25	V
Quiescent Supply Current	$f_{SCLK} = 50$ kSPS		1.5	1.9	mA
Power-Down Current			1.0		mA
Turn-On Time ⁶	$C_X, C_Y = 0.1$ μ F		20		ms

¹ Guaranteed by measurement of initial offset and sensitivity.

² Defined as the output change from ambient-to-maximum temperature or ambient-to-minimum temperature.

³ Actual bandwidth response controlled by user-supplied external capacitor (C_X, C_Y).

⁴ See the Setting the Bandwidth section for more information on how to reduce the bandwidth.

⁵ Self-test response changes as the square of V_{CC} .

⁶ Larger values of C_X and C_Y increase turn-on time. Turn-on time is approximately $(160 \times (0.0022 + C_X \text{ or } C_Y) + 4)$ in milliseconds, where C_X and C_Y are in μ F.

TIMING SPECIFICATIONS

$T_A = -40^\circ\text{C}$ to $+125^\circ\text{C}$, acceleration = 0 g, unless otherwise noted.

Table 2.

Parameter ^{1, 2}	$V_{CC} = 3.3$ V	$V_{CC} = 5$ V	Unit	Description
f_{SCLK} ³	10 2	10 2	kHz min MHz max	
$t_{CONVERT}$	$14.5 \times t_{SCLK}$	$14.5 \times t_{SCLK}$		Throughput time = $t_{CONVERT} + t_{ACQ} = 16 \times t_{SCLK}$
t_{ACQ}	$1.5 \times t_{SCLK}$	$1.5 \times t_{SCLK}$		$\overline{TCS}/\overline{CS}$ to SCLK setup time
t_1	10	10	ns min	
t_2 ⁴	60	30	ns max	Delay from $\overline{TCS}/\overline{CS}$ until DOUT three-state disabled
t_3 ⁴	100	75	ns max	Data access time after SCLK falling edge
t_4	20	20	ns min	Data setup time prior to SCLK rising edge
t_5	20	20	ns min	Data hold time after SCLK rising edge
t_6	$0.4 \times t_{SCLK}$	$0.4 \times t_{SCLK}$	ns min	SCLK high pulse width
t_7	$0.4 \times t_{SCLK}$	$0.4 \times t_{SCLK}$	ns min	SCLK low pulse width
t_8 ⁵	80	80	ns max	$\overline{TCS}/\overline{CS}$ rising edge to DOUT high impedance
t_9 ⁶	5	5	μ s typ	Power-up time from shutdown

¹ Guaranteed by design. All input signals are specified with t_R and $t_F = 5$ ns (10% to 90% of V_{CC}) and timed from a voltage level of 1.6 V. The 3.3 V operating range spans from 3.0 V to 3.6 V. The 5 V operating range spans from 4.75 V to 5.25 V.

² See Figure 3 and Figure 4.

³ Mark/space ratio for the SCLK input is 40/60 to 60/40.

⁴ Measured with the load circuit in Figure 2 and defined as the time required for the output to cross 0.4 V or 2.0 V with $V_{CC} = 3.3$ V and time for an output to cross 0.8 V or 2.4 V with $V_{CC} = 5.0$ V.

⁵ t_8 is derived from the measured time taken by the data outputs to change 0.5 V when loaded with the circuit in Figure 2. The measured number is then extrapolated back to remove the effects of charging or discharging the 50 pF capacitor. This means that the time, t_8 , quoted in the Timing Specifications is the true bus relinquish time of the part and is independent of the bus loading.

⁶ Shutdown recovery time denotes the time it takes to start producing samples and does not account for the recovery time of the sensor, which is dependent on the overall bandwidth.

CIRCUIT AND TIMING DIAGRAMS

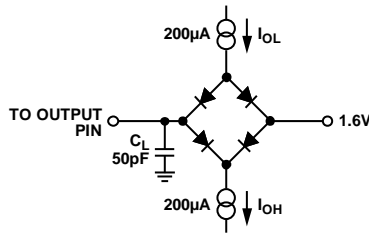

Figure 2. Load Circuit for Digital Output Timing Specifications

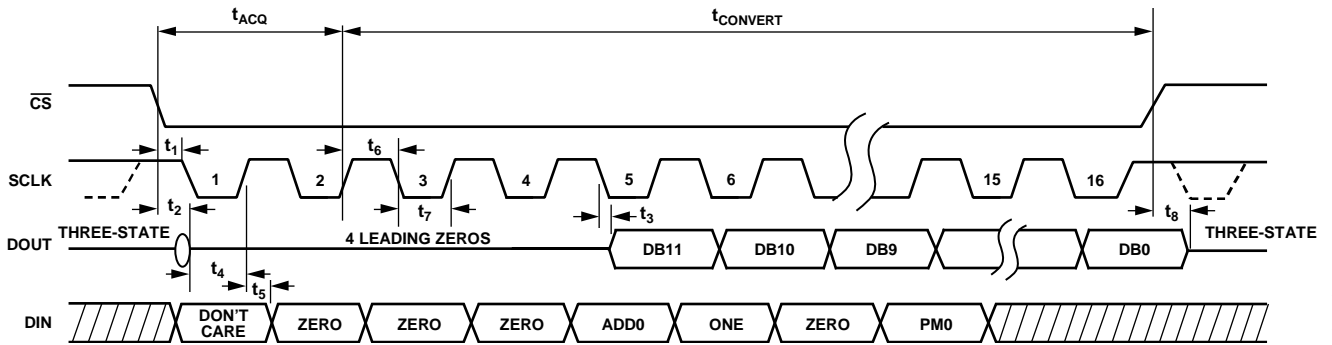

Figure 3. Accelerometer Serial Interface Timing Diagram

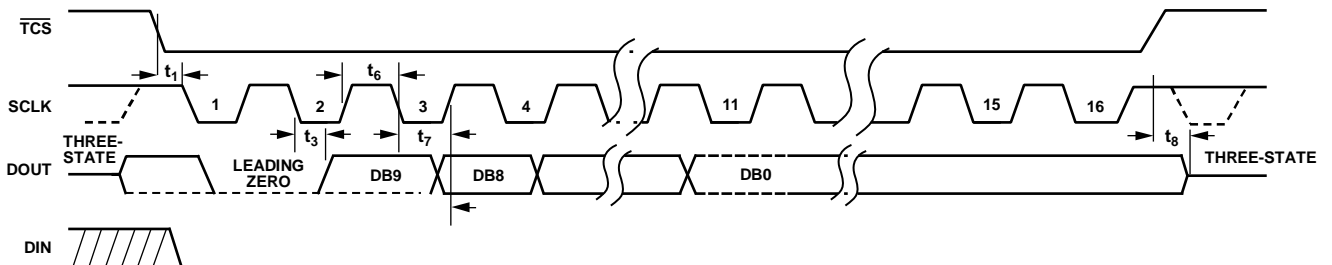

Figure 4. Temperature Serial Interface Timing Diagram

ABSOLUTE MAXIMUM RATINGS

Table 3.

Parameter	Rating
Acceleration (Any Axis, Unpowered)	3500 g
Acceleration (Any Axis, Powered)	3500 g
V _{CC}	-0.3 V to +7.0 V
All Other Pins	(COM - 0.3V) to (V _{CC} + 0.3 V)
Output Short-Circuit Duration (Any Pin to Common)	Indefinite
Operating Temperature Range	-40°C to +125°C
Storage Temperature Range	-65°C to +150°C

Stresses above those listed under Absolute Maximum Ratings may cause permanent damage to the device. This is a stress rating only; functional operation of the device at these or any other conditions above those indicated in the operational section of this specification is not implied. Exposure to absolute maximum rating conditions for extended periods may affect device reliability.

Table 4. Package Characteristics

Package Type	θ _{JA}	θ _{JC}	Device Weight
12-Terminal LGA	200°C/W	25°C/W	0.3 grams

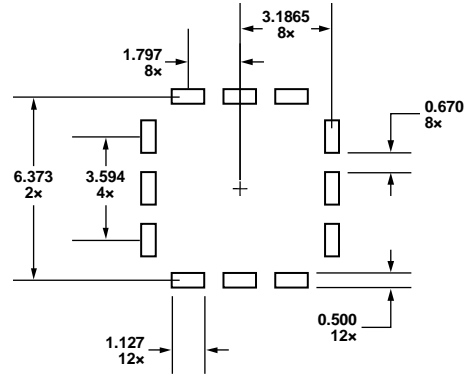

7.2mm x 7.2mm STACKED LGA. ALL DIMENSIONS IN mm.

Figure 5. Second-Level Assembly Pad Layout

03975-005

ESD CAUTION



ESD (electrostatic discharge) sensitive device. Charged devices and circuit boards can discharge without detection. Although this product features patented or proprietary protection circuitry, damage may occur on devices subjected to high energy ESD. Therefore, proper ESD precautions should be taken to avoid performance degradation or loss of functionality.

PIN CONFIGURATION AND FUNCTION DESCRIPTIONS

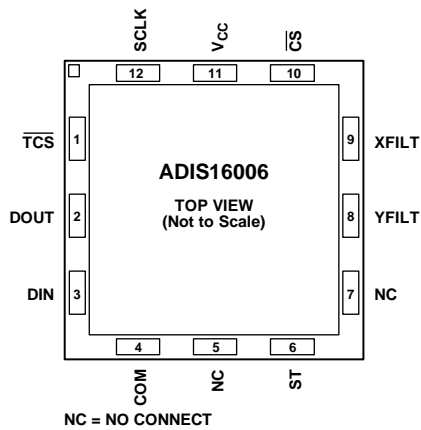

Figure 6. Pin Configuration

Table 5. Pin Function Descriptions

Pin No.	Mnemonic	Description
1	\overline{TCS}	Temperature Chip Select. Active low logic input. This input frames the serial data transfer for the temperature sensor output.
2	DOUT	Data Out, Logic Output. The conversion of the ADIS16006 is provided on this output as a serial data stream. The bits are clocked out on the falling edge of the SCLK input.
3	DIN	Data In, Logic Input. Data to be written into the control register of the ADIS16006 is provided on this input and is clocked into the register on the rising edge of SCLK.
4	COM	Common. Reference point for all circuitry on the ADIS16006 .
5, 7	NC	No Connect.
6	ST	Self-Test Input. Active high logic input. Simulates a nominal 0.75 g test input for diagnostic purpose.
8	YFILT	Y-Channel Filter Node. Used in conjunction with an optional external capacitor to band limit the noise contribution from the accelerometer.
9	XFILT	X-Channel Filter Node. Used in conjunction with an optional external capacitor to band limit the noise contribution from the accelerometer.
10	\overline{CS}	Chip Select. Active low logic input. This input provides the dual function of initiating the accelerometer conversions on the ADIS16006 and framing the serial data transfer for the accelerometer output.
11	V_{CC}	Power Supply Input. The V_{CC} range for the ADIS16006 is 3.0 V to 5.25 V.
12	SCLK	Serial Clock, Logic Input. SCLK provides the serial clock for accessing data from the part and writing serial data to the control register. This clock input is also used as the clock source for the conversion process of the ADIS16006 .

TYPICAL PERFORMANCE CHARACTERISTICS

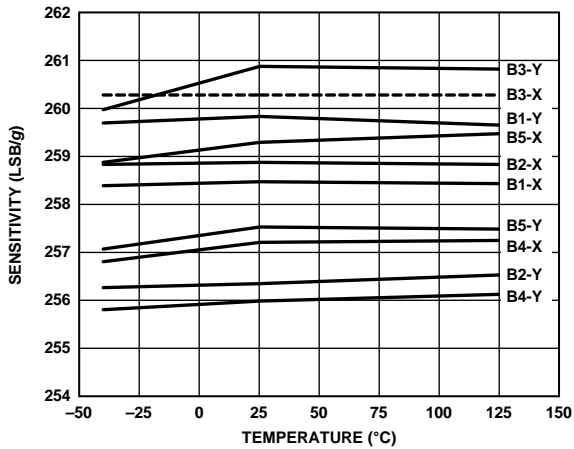

Figure 7. Sensitivity vs. Temperature (± 1 g Stimulus)

05975-007

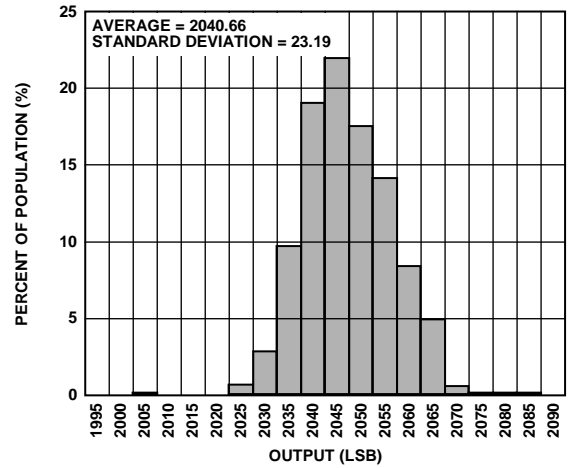

Figure 10. X-Axis 0 g Bias at 25°C

05975-010

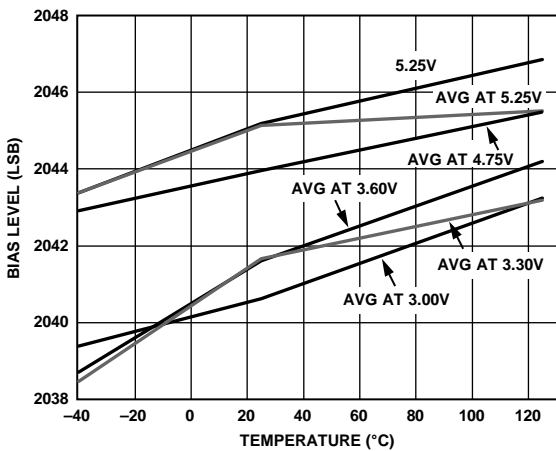

Figure 8. X-Axis 0 g Bias vs. Temperature

05975-008

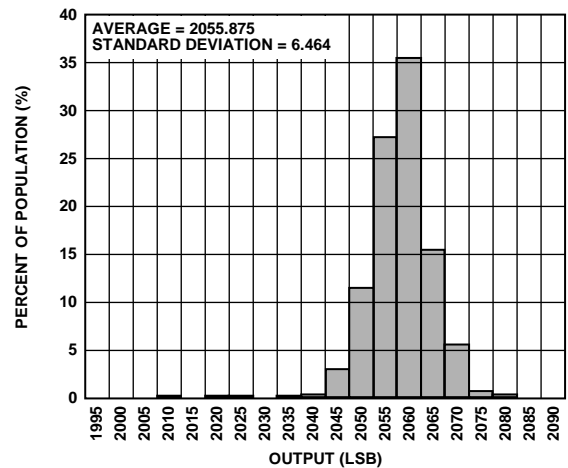

Figure 11. Y-Axis 0 g Bias at 25°C

05975-011

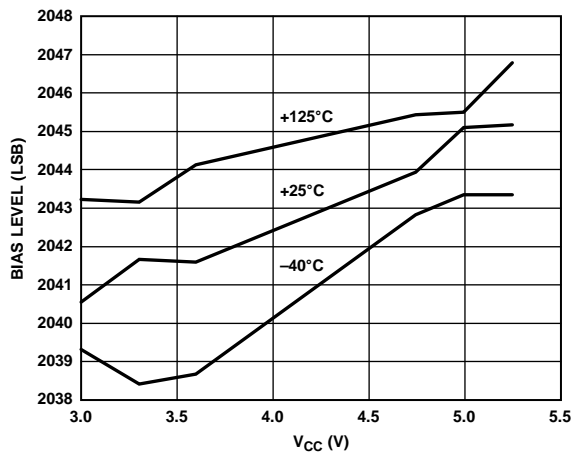

Figure 9. X-Axis 0 g Bias vs. Supply Voltage

05975-009

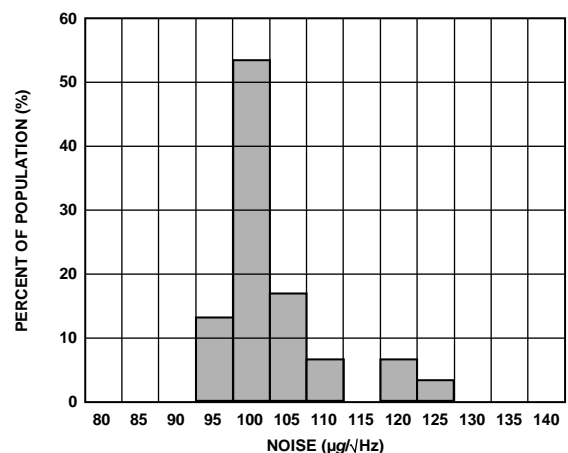

Figure 12. Noise (X-Axis) at V_{CC} = 5 V, 25°C

05975-012

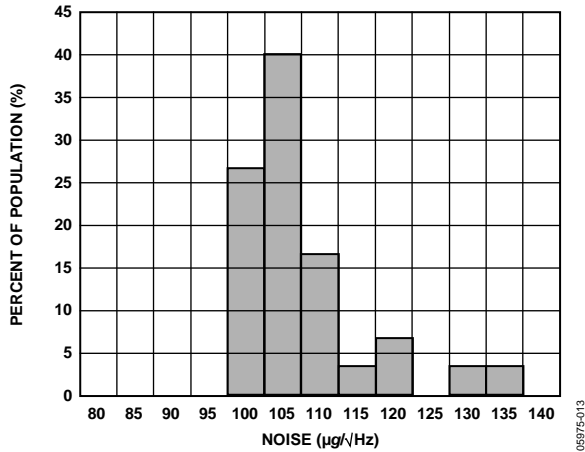

Figure 13. Noise (Y-Axis) at $V_{CC} = 5\text{ V}$, 25°C

05975-013

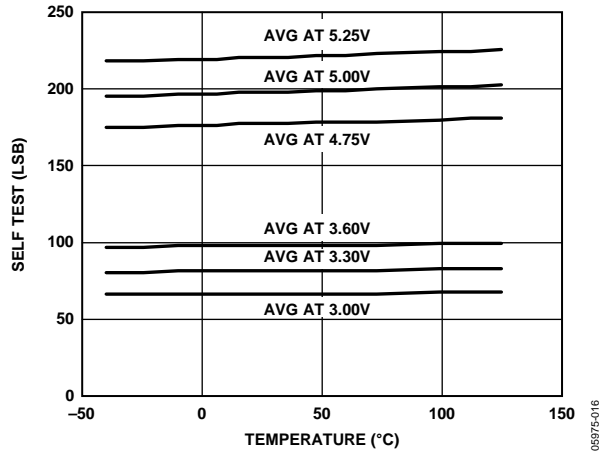

Figure 16. Self-Test X-Axis vs. Temperature

05975-016

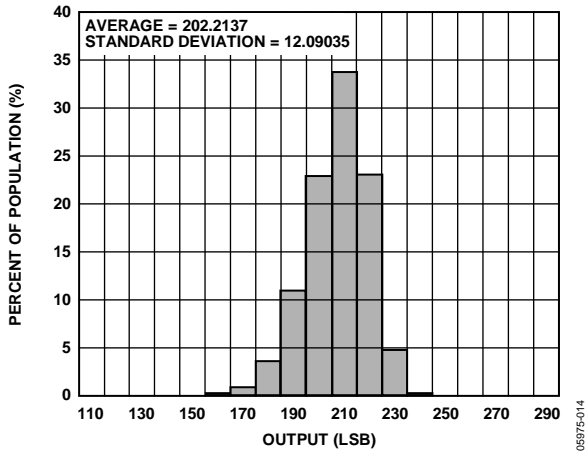

Figure 14. X-Axis Self-Test at $V_{CC} = 5\text{ V}$, 25°C

05975-014

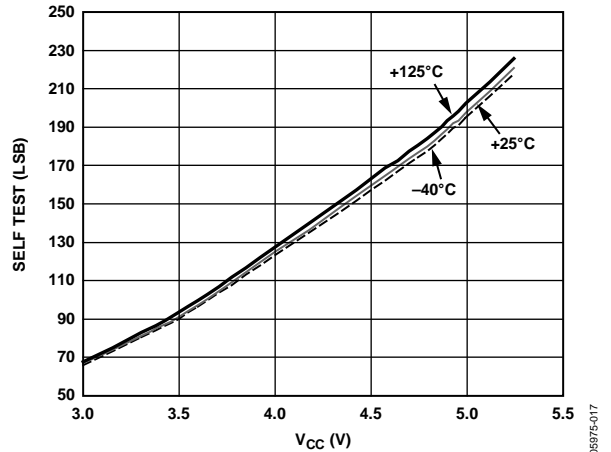

Figure 17. Self-Test X-Axis vs. Supply Voltage

05975-017

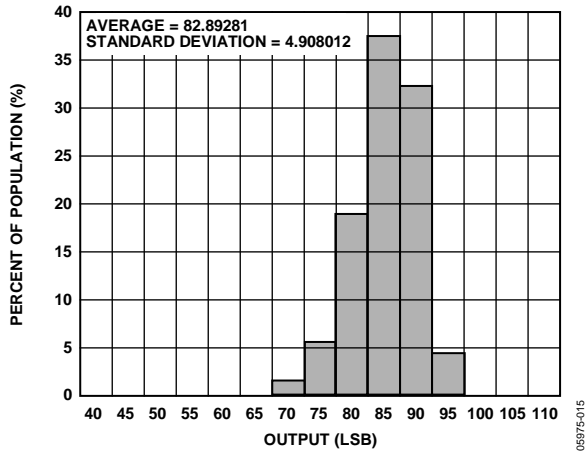

Figure 15. X-Axis Self-Test at $V_{CC} = 3.3\text{ V}$, 25°C

05975-015

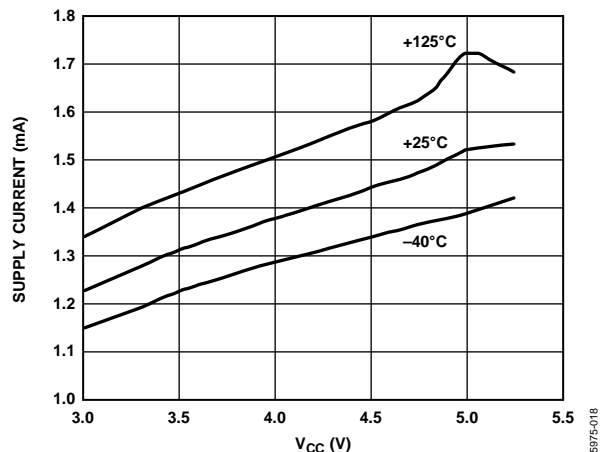

Figure 18. Supply Current vs. Supply Voltage

05975-018

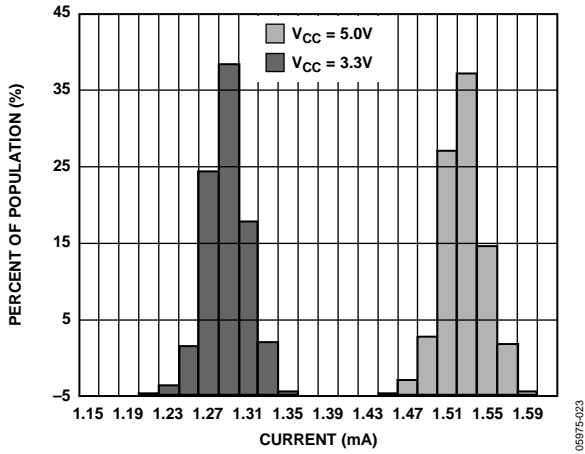

Figure 19. Supply Current at 25°C

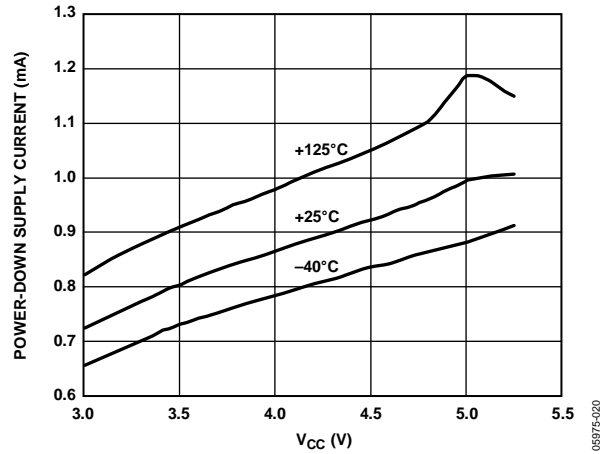

Figure 21. Power-Down Supply Current vs. Supply Voltage

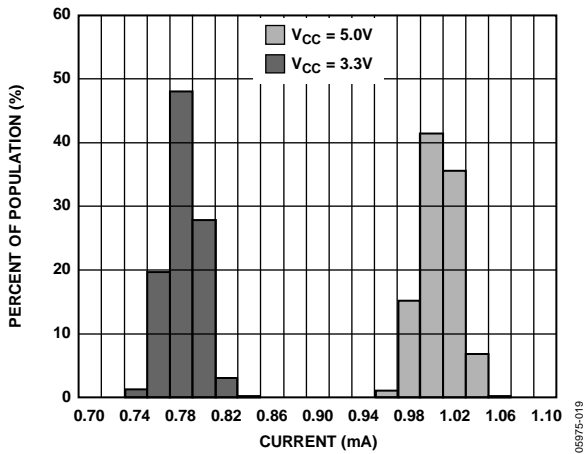

Figure 20. Power-Down Supply Current

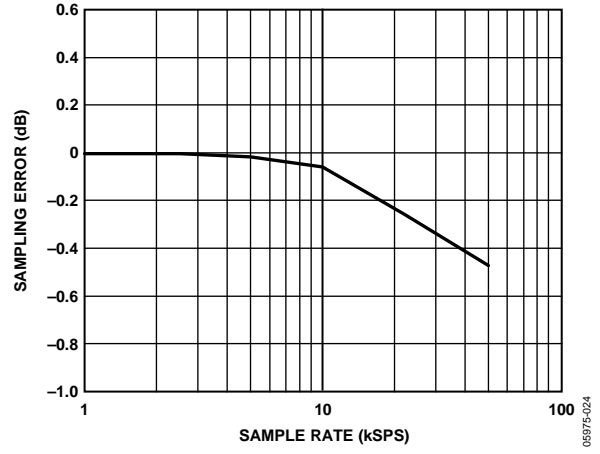

Figure 22. Sampling Error vs. Sampling Frequency

THEORY OF OPERATION

The ADIS16006 is a low cost, low power, complete dual-axis accelerometer with an integrated serial peripheral interface (SPI) and an integrated temperature sensor whose output is also available on the SPI interface. The ADIS16006 is capable of measuring acceleration with a full-scale range of ± 5 g (minimum). The ADIS16006 can measure both dynamic acceleration (vibration) and static acceleration (gravity).

ACCELEROMETER DATA FORMAT

The accelerometer data is in a 12-bit, offset binary format. See Table 6 for examples of this data format.

Table 6. Acceleration Data Format Examples

Acceleration (g)	Decimal	Hex	Binary
+5	3328	0xD00	1101 0000 0000
+2/256	2050	0x802	1000 0000 0010
+1/256	2049	0x801	1000 0000 0001
0	2048	0x800	1000 0000 0000
-1/256	2047	0x7FF	0111 1111 1111
-2/256	2046	0x7FE	0111 1111 1110
-5	768	0x300	0011 0000 0000

SELF-TEST

The ST pin controls the self-test feature. When this pin is set to V_{CC} , an electrostatic force is exerted on the beam of the accelerometer. The resulting movement of the beam allows the user to test if the accelerometer is functional. The typical change in output is 801 mg (corresponding to 205 LSB) for $V_{CC} = 5.0$ V. This pin can be left open-circuit or connected to common in normal use. The ST pin should never be exposed to voltage greater than $V_{CC} + 0.3$ V. If the system design is such that this condition cannot be guaranteed (for example, multiple supply voltages are present), a low V_F clamping diode between ST and V_{CC} is recommended.

SERIAL INTERFACE

The serial interface on the ADIS16006 consists of five wires: \overline{CS} , \overline{TCS} , SCLK, DIN, and DOUT. Both accelerometer axes and the temperature sensor data are available on the serial interface. The \overline{CS} and \overline{TCS} are used to select the accelerometer or temperature sensor outputs, respectively. \overline{CS} and \overline{TCS} cannot be active at the same time.

The SCLK input accesses data from the internal data registers.

ACCELEROMETER SERIAL INTERFACE

Figure 3 shows the detailed timing diagram for serial interfacing to the accelerometer in the ADIS16006. The serial clock provides the conversion clock. \overline{CS} initiates the conversion process and data transfer and frames the serial data transfer for the accelerometer output. The accelerometer output is sampled on the second rising edge of the SCLK input after the falling edge of \overline{CS} . The conversion requires 16 SCLK cycles to complete. The rising edge of \overline{CS} puts the bus back into three-state. If \overline{CS} remains

low, the next digital conversion is initiated. The details for the control register bit functions are shown in Table 7.

Accelerometer Control Register

MSB						LSB	
DONTC	ZERO	ZERO	ZERO	ADD0	ONE	ZERO	PM0

Table 7. Accelerometer Control Register Bit Functions

Bit	Mnemonic	Comments
7	DONTC	Don't care. Can be 1 or 0.
6, 5, 4	ZERO	These bits should be held low.
3	ADD0	This address bit selects the x-axis or y-axis outputs. A 0 selects the x-axis; a 1 selects the y-axis.
2	ONE	This bit should be held high.
1	ZERO	This bit should be held low.
0	PM0	This bit selects the operation mode for the accelerometer; set to 0 for normal operation and 1 for power-down mode.

Power-Down

By setting PM0 to 1 when updating the accelerometer control register, the ADIS16006 goes into shutdown mode. The information stored in the control register is maintained during shutdown. The ADIS16006 changes modes as soon as the control register is updated. If the part is in shutdown mode and PM0 is changed to 0, the part powers up on the 16th SCLK rising edge.

ADD0

By setting ADD0 to 0 when updating the accelerometer control register, the x-axis output is selected. By setting ADD0 to 1, the y-axis output is selected.

ZERO

ZERO is defined as the Logic low level.

ONE

ONE is defined as the Logic high level.

DONTC

DONTC is defined as don't care and can be a low or high logic level.

Accelerometer Conversion Details

Every time the accelerometer is sampled, the sampling function discharges the internal C_X or C_Y filtering capacitors by up to 2% of their initial values (assuming no additional external filtering capacitors are added). The recovery time for the filter capacitor to recharge is approximately 10 μ s. Therefore, sampling the accelerometer at a rate of 10 kSPS or less does not induce a sampling error. However, as sampling frequencies increase above 10 kSPS, one can expect sampling errors to attenuate the actual acceleration levels.

TEMPERATURE SENSOR SERIAL INTERFACE

Read Operation

Figure 4 shows the timing diagram for a serial read from the temperature sensor. The $\overline{\text{TCS}}$ line enables the SCLK input. Ten bits of data and a leading zero are transferred during a read operation. Read operations occur during streams of 16 clock pulses. The serial data can be received into two bytes to accommodate the entire 10-bit data stream. If only eight bits of resolution are required, the data can be received into a single byte. At the end of the read operation, the DOUT line remains in the state of the last bit of data clocked out until $\overline{\text{TCS}}$ goes high, at which time the DOUT line from the temperature sensor goes three-state.

Write Operation

Figure 4 also shows the timing diagram for the serial write to the temperature sensor. The write operation takes place at the same time as the read operation. Data is clocked into the control register on the rising edge of SCLK. DIN should remain low for the entire cycle.

Temperature Sensor Control Register

MSB							LSB
ZERO	ZERO	ZERO	ZERO	ZERO	ZERO	ZERO	ZERO

Table 8. Temperature Sensor Control Register Bit Functions

Bit	Mnemonic	Comments
7 to 0	ZERO	All bits should be held low.

ZERO

ZERO is defined as the Logic low level.

Output Data Format

The output data format for the temperature sensor is twos complement. Table 9 shows the relationship between the temperature and the digital output.

Table 9. Temperature Sensor Data Format

Temperature	Digital Output (DB9 ... DB0)
-40°C	11 0110 0000
-25°C	11 1001 1100
-0.25°C	11 1111 1111
0°C	00 0000 0000
+0.25°C	00 0000 0001
+10°C	00 0010 1000
+25°C	00 0110 0100
+50°C	00 1100 1000
+75°C	01 0010 1100
+100°C	01 1001 0000
+125°C	01 1111 0100

Temperature Sensor Conversion Details

The ADIS16006 features a 10-bit digital temperature sensor that allows an accurate measurement of the ambient device temperature to be made.

The conversion clock for the temperature sensor is internally generated; therefore, no external clock is required except when reading from and writing to the serial port. In normal mode, an internal clock oscillator runs the automatic conversion sequence. A conversion is initiated approximately every 350 μs . At this time, the temperature sensor wakes up and performs a temperature conversion. This temperature conversion typically takes 25 μs , at which time the temperature sensor automatically shuts down. The result of the most recent temperature conversion is available in the serial output register at any time. Once the conversion is finished, an internal oscillator starts counting and is designed to time out every 350 μs . The temperature sensor then powers up and does a conversion.

If the $\overline{\text{TCS}}$ is brought low every 350 μs ($\pm 30\%$) or less, the same temperature value is output onto the DOUT line every time without changing. It is recommended that the $\overline{\text{TCS}}$ line not be brought low every 350 μs ($\pm 30\%$) or less. The $\pm 30\%$ covers process variation. The $\overline{\text{TCS}}$ should become active (high to low) outside this range.

The device is designed to autoconvert every 350 μs . If the temperature sensor is accessed during the conversion process, an internal signal is generated to prevent any update of the temperature value register during the conversion. This prevents the user from reading back spurious data. The design of this feature results in this internal lockout signal being reset only at the start of the next autoconversion. Therefore, if the $\overline{\text{TCS}}$ line goes active before the internal lockout signal is reset to its inactive mode, the internal lockout signal is not reset. To ensure that no lockout signal is set, bring $\overline{\text{TCS}}$ low at a greater time than 350 μs ($\pm 30\%$). As a result, the temperature sensor is not interrupted during a conversion process.

In the automatic conversion mode, every time a read or write operation takes place, the internal clock oscillator is restarted at the end of the read or write operation. The result of the conversion is typically available 25 μs later. Reading from the device before conversion is complete provides the same set of data.

POWER SUPPLY DECOUPLING

The ADIS16006 integrates two decoupling capacitors that are 0.047 μF in value. For local operation of the ADIS16006, no additional power supply decoupling capacitance is required. However, if the system power supply presents a substantial amount of noise, additional filtering can be required. If additional capacitors are required, connect the ground terminal of each of these capacitors directly to the underlying ground plane. Finally, note that all analog and digital grounds should be referenced to the same system ground reference point.

SETTING THE BANDWIDTH

The ADIS16006 has provisions for band limiting the accelerometer. Capacitors can be added at the XFILT pin and the YFILT pin to implement further low-pass filtering for antialiasing and noise reduction. The equation for the 3 dB bandwidth is

$$f_{-3dB} = 1/(2\pi(32 \text{ k}\Omega) \times (C_{XFILT, YFILT} + 2200 \text{ pF}))$$

or more simply,

$$f_{-3dB} = 5 \mu\text{F}/(C_{XFILT, YFILT} + 2200 \text{ pF})$$

The tolerance of the internal resistor (R_{FILT}) can vary typically as much as $\pm 25\%$ of its nominal value (32 k Ω); thus, the bandwidth varies accordingly.

A minimum capacitance of 0 pF for C_{XFILT} and C_{YFILT} is allowable.

Table 10. Filter Capacitor Selection, C_{XFILT} and C_{YFILT}

Bandwidth (Hz)	Capacitor (μF)
1	4.7
10	0.47
50	0.10
100	0.047
200	0.022
400	0.01
2250	0

SELECTING FILTER CHARACTERISTICS: THE NOISE/BANDWIDTH TRADE-OFF

The accelerometer bandwidth selected ultimately determines the measurement resolution (smallest detectable acceleration). Filtering can be used to lower the noise floor, which improves the resolution of the accelerometer. Resolution is dependent on the analog filter bandwidth at XFILT and YFILT.

The ADIS16006 has a typical bandwidth of 2.25 kHz with no external filtering. The analog bandwidth can be further decreased to reduce noise and improve resolution.

The ADIS16006 noise has the characteristics of white Gaussian noise, which contributes equally at all frequencies and is described in terms of $\mu\text{g}/\sqrt{\text{Hz}}$ (that is, the noise is proportional to the square root of the bandwidth of the accelerometer). The user should limit bandwidth to the lowest frequency needed by the application to maximize the resolution and dynamic range of the accelerometer.

With the single-pole, roll-off characteristic, the typical noise of the ADIS16006 is determined by

$$rmsNoise = (200 \mu\text{g}/\sqrt{\text{Hz}}) \times (\sqrt{BW \times 1.57})$$

At 100 Hz, the noise is

$$rmsNoise = (200 \mu\text{g}/\sqrt{\text{Hz}}) \times (\sqrt{100 \times 1.57}) = 2.5 \text{ mg}$$

Often, the peak value of the noise is desired. Peak-to-peak noise can only be estimated by statistical methods. Table 11 is useful for estimating the probabilities of exceeding various peak values, given the rms value.

Table 11. Estimation of Peak-to-Peak Noise

Peak-to-Peak Value	Percentage of Time Noise Exceeds Nominal Peak-to-Peak Value (%)
2 \times rms	32
4 \times rms	4.6
6 \times rms	0.27
8 \times rms	0.006

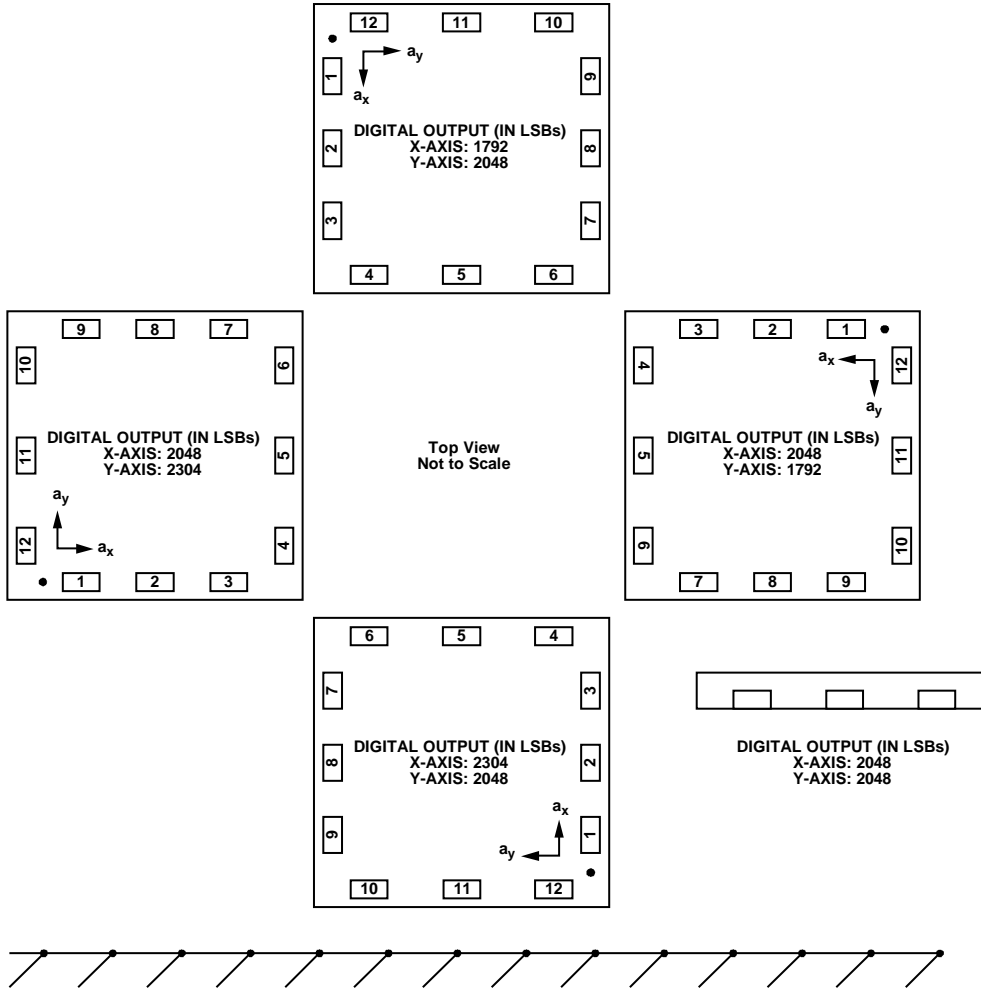

Figure 23. Output Response vs. Orientation

05875-021

APPLICATIONS

SECOND LEVEL ASSEMBLY

The [ADIS16006](#) can be attached to the second level assembly board using SN63 (or equivalent) or lead-free solder. IPC/ JEDEC J-STD-020 and J-STD-033 provide standard handling procedures for these types of packages.

OUTLINE DIMENSIONS

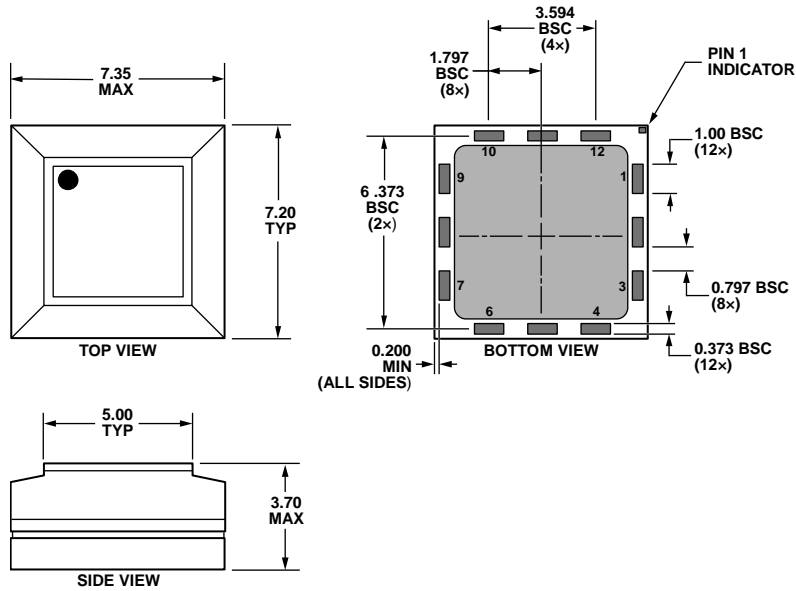

Figure 24. 12-Terminal Land Grid Array [LGA]
(CC-12-1)
Dimensions shown in millimeters

082407-C

ORDERING GUIDE

Model ¹	Temperature Range	Package Description	Package Option
ADIS16006CCCZ	-40°C to +125°C	12-Terminal Land Grid Array (LGA)	CC-12-1
ADIS16006/PCBZ		Evaluation Board	

¹ Z = RoHS Compliant Part.

Looking for pricing, stock, or lifecycle information?

Click below to explore more details on WIN SOURCE:

 [View ADIS16006CCCZ on WIN SOURCE](#)

 [Analog Devices Inc. Information](#)

Optimize Your Supply Chain with WIN SOURCE Solutions

-  Global Sourcing Solution
-  Obsolete Management
-  Cost Control Management
-  Shortage Management
-  Alternative Solution
-  Excess Inventory Management