



**THE DATASHEET OF
ADAU1961WBCPZ-R7**



Stereo, Low Power, 96 kHz, 24-Bit Audio Codec with Integrated PLL

FEATURES

- ▶ 24-bit stereo audio ADC and DAC: >98 dB SNR
- ▶ Sampling rates from 8 kHz to 96 kHz
- ▶ Low power: 17 mW record, 18 mW playback, 48 kHz
- ▶ 6 analog input pins, configurable for single-ended or differential inputs
- ▶ Flexible analog input/output mixers
- ▶ Stereo digital microphone input
- ▶ Analog outputs: 2 differential stereo, 2 single-ended stereo, 1 mono headphone output driver
- ▶ PLL supporting input clocks from 8 MHz to 27 MHz
- ▶ Analog automatic level control (ALC)
- ▶ Microphone bias reference voltage
- ▶ Analog and digital I/O: 3.3 V
- ▶ I²C and SPI control interfaces
- ▶ Digital audio serial data I/O: stereo and time-division multiplexing (TDM) modes
- ▶ Software-controllable clickless mute
- ▶ 32-lead, 5 mm × 5 mm LFCSP
- ▶ -40°C to +105°C operating temperature range
- ▶ AEC-Q100 qualified for automotive applications

APPLICATIONS

- ▶ Automotive head units
- ▶ Automotive amplifiers
- ▶ Navigation systems
- ▶ Rear-seat entertainment systems

FUNCTIONAL BLOCK DIAGRAM

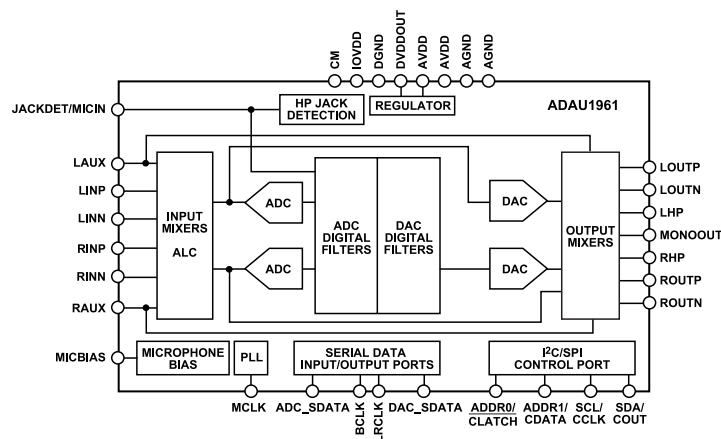

Figure 1.

GENERAL DESCRIPTION

The ADAU1961 is a low power, stereo audio codec that supports stereo 48 kHz record and playback at 35 mW from a 3.3 V analog supply. The stereo audio ADCs and DACs support sample rates from 8 kHz to 96 kHz as well as a digital volume control.

The record path includes an integrated microphone bias circuit and six inputs. The inputs can be mixed and muxed before the ADC, or they can be configured to bypass the ADC. The ADAU1961 includes a stereo digital microphone input.

The ADAU1961 includes five high power output drivers (two differential and three single-ended), supporting stereo head-phones, an earpiece, or other output transducer. AC-coupled or capless configurations are supported. Individual fine level controls are supported on all analog outputs. The output mixer stage allows for flexible routing of audio.

The serial control bus supports the I²C and SPI protocols. The serial audio bus is programmable for I²S, left-/right-justified, and TDM modes. A programmable PLL supports flexible clock generation for all standard integer rates and fractional main clocks from 8 MHz to 27 MHz.

TABLE OF CONTENTS

Features.....	1	Sampling Rates.....	24
Applications.....	1	PLL.....	25
General Description.....	1	Record Signal Path.....	27
Functional Block Diagram.....	1	Input Signal Paths.....	27
Specifications.....	3	Analog-to-Digital Converters.....	29
Analog Performance Specifications, $T_A = 25^\circ\text{C}$	3	Automatic Level Control (ALC).....	30
Analog Performance Specifications, $-40^\circ\text{C} < T_A < +105^\circ\text{C}$	5	ALC Parameters.....	30
Power Supply Specifications.....	7	Noise Gate Function.....	31
Digital Filters.....	8	Playback Signal Path.....	33
Digital Input/Output Specifications.....	8	Output Signal Paths.....	33
Digital Timing Specifications.....	9	Headphone Output.....	33
Digital Timing Diagrams.....	10	Pop-and-Click Suppression.....	35
Absolute Maximum Ratings.....	12	Line Outputs.....	35
Thermal Resistance.....	12	Control Ports.....	36
ESD Caution.....	12	Burst Mode Writing and Reading.....	36
Pin Configuration and Function Descriptions.....	13	I ² C Port.....	36
Typical Performance Characteristics.....	15	SPI Port.....	39
System Block Diagrams.....	18	Serial Data Input/Output Ports.....	40
Theory of Operation.....	21	Applications Information.....	42
Startup, Initialization, and Power.....	22	Power Supply Bypass Capacitors.....	42
Power-Up Sequence.....	22	GSM Noise Filter.....	42
Power Reduction Modes.....	22	Grounding.....	42
Digital Power Supply.....	22	Exposed Pad PCB Design.....	42
Input/Output Power Supply.....	22	Control Registers.....	43
Clock Generation and Management.....	22	Control Register Details.....	44
Clocking and Sampling Rates.....	24	Outline Dimensions.....	73
Core Clock.....	24	Ordering Guide.....	73
		Automotive Products.....	73

REVISION HISTORY

7/2024—Rev. A to Rev. B

Changed Master to Main and Slave to Subordinate (Throughout).....	1
Updated Outline Dimensions.....	73

SPECIFICATIONS

Supply voltage (AVDD) = 3.3 V, $T_A = 25^\circ\text{C}$, main clock = 12.288 MHz (48 kHz f_S , $256 \times f_S$ mode), input sample rate = 48 kHz, measurement bandwidth = 20 Hz to 20 kHz, word width = 24 bits, C_{LOAD} (digital output) = 20 pF, I_{LOAD} (digital output) = 2 mA, $V_{IH} = 2$ V, $V_{IL} = 0.8$ V, unless otherwise noted. Performance of all channels is identical, exclusive of the interchannel gain mismatch and interchannel phase deviation specifications.

ANALOG PERFORMANCE SPECIFICATIONS, $T_A = 25^\circ\text{C}$

IOVDD = 3.3 V \pm 10%.

Table 1.

Parameter	Test Conditions/Comments	Min	Typ	Max	Unit
ANALOG-TO-DIGITAL CONVERTERS					
ADC Resolution	ADC performance excludes mixers and PGA All ADCs		24		Bits
Digital Attenuation Step			0.375		dB
Digital Attenuation Range			95		dB
INPUT RESISTANCE					
Single-Ended Line Input	-12 dB gain		80.4		k Ω
	0 dB gain		21		k Ω
	6 dB gain		10.5		k Ω
PGA Inverting Inputs	-12 dB gain		84.5		k Ω
	0 dB gain		53		k Ω
	35.25 dB gain		1.7		k Ω
PGA Noninverting Inputs	All gains		105		k Ω
SINGLE-ENDED LINE INPUT					
Full-Scale Input Voltage (0 dB)			1.0 (2.83)		V rms (V p-p)
Dynamic Range	20 Hz to 20 kHz, -60 dB input				
With A-Weighted Filter (RMS)		83.5	99		dB
No Filter (RMS)		83	96		dB
Total Harmonic Distortion + Noise	-1 dBFS		-90	-71	dB
Signal-to-Noise Ratio					
With A-Weighted Filter (RMS)			99		dB
No Filter (RMS)			96		dB
Input Mixer Gain per Step	-12 dB to +6 dB range	2.89	3	3.07	dB
Mute Attenuation	LINPG[2:0], LINNG[2:0] = 000, RINPG[2:0], RINNG[2:0] = 000, MX1AUXG[2:0], MX2AUXG[2:0] = 000		-85.5	-77	dB
Interchannel Gain Mismatch		-0.3	+0.032	+0.3	dB
Offset Error		-5	0	+5	mV
Gain Error		-17	-12	-8	%
Interchannel Isolation			68		dB
Power Supply Rejection Ratio	CM capacitor = 20 μ F, 100 mV p-p @ 1 kHz		67		dB
PSEUDO-DIFFERENTIAL PGA INPUT					
Full-Scale Input Voltage (0 dB)			1.0 (2.83)		V rms (V p-p)
Dynamic Range	20 Hz to 20 kHz, -60 dB input				
With A-Weighted Filter (RMS)		94	98		dB
No Filter (RMS)		91	95		dB
Total Harmonic Distortion + Noise	-1 dBFS		-89	-83	dB
Signal-to-Noise Ratio					
With A-Weighted Filter (RMS)			98		dB
No Filter (RMS)			95		dB
PGA Boost Gain Error	20 dB gain setting (RDBOOST[1:0], LDBOOST[1:0] = 10)	-8	+0.4	+8	dB

SPECIFICATIONS

Table 1. (Continued)

Parameter	Test Conditions/Comments	Min	Typ	Max	Unit
Mute Attenuation	PGA muted LDMUTE, RDMUTE = 0 RDBOOST[1:0], LDBOOST[1:0] = 00		-76 -87	-73 -82	dB dB
Interchannel Gain Mismatch		-0.6	-0.073	+0.6	dB
Offset Error		-6	0	+6	mV
Gain Error		-24	-14	-3	%
Interchannel Isolation			83		dB
Common-Mode Rejection Ratio	100 mV rms, 1 kHz 100 mV rms, 20 kHz		-58 -48		dB dB
FULL DIFFERENTIAL PGA INPUT					
Full-Scale Input Voltage (0 dB)	Differential PGA inputs		1.0 (2.83)		V rms (V p-p)
Dynamic Range	20 Hz to 20 kHz, -60 dB input				
With A-Weighted Filter (RMS)		94	98		dB
No Filter (RMS)		91	95		dB
Total Harmonic Distortion + Noise	-1 dBFS		-78	-74	dB
Signal-to-Noise Ratio					
With A-Weighted Filter (RMS)			98		dB
No Filter (RMS)			95		dB
PGA Boost Gain Error	20 dB gain setting (RDBOOST[1:0], LDBOOST[1:0] = 10)	-8	-0.15	+8	dB
Mute Attenuation	PGA muted LDMUTE, RDMUTE = 0 RDBOOST[1:0], LDBOOST[1:0] = 00		-76 -87	-73 -82	dB dB
Interchannel Gain Mismatch		-0.3	-0.0005	+0.3	dB
Offset Error		-6	0	+6	mV
Gain Error		-17	-14	-9	%
Interchannel Isolation			83		dB
Common-Mode Rejection Ratio	100 mV rms, 1 kHz 100 mV rms, 20 kHz		-58 -48		dB dB
MICROPHONE BIAS					
MBIEN = 1					
Bias Voltage					
0.65 × AVDD	MBI = 1, MPERF = 0 MBI = 1, MPERF = 1	2.00 2.04	2.145 2.13	2.19 2.21	V V
0.90 × AVDD	MBI = 0, MPERF = 0 MBI = 0, MPERF = 1	2.89 2.89	2.97 2.99	3.04 3.11	V V
Bias Current Source	MBI = 0, MPERF = 1			3	mA
Noise in the Signal Bandwidth	1 kHz to 20 kHz				
MBI = 0, MPERF = 0			42		nV/√Hz
MBI = 0, MPERF = 1			85		nV/√Hz
MBI = 1, MPERF = 0			25		nV/√Hz
MBI = 1, MPERF = 1		13	22	36	nV/√Hz
DIGITAL-TO-ANALOG CONVERTERS					
DAC Resolution	DAC performance excludes mixers and headphone amplifier All DACs		24		Bits
Digital Attenuation Step			0.375		dB
Digital Attenuation Range			95		dB
DAC TO LINE OUTPUT					
Full-Scale Output Voltage (0 dB)			0.92 (2.60)		V rms (V p-p)

SPECIFICATIONS

Table 1. (Continued)

Parameter	Test Conditions/Comments	Min	Typ	Max	Unit
Dynamic Range	20 Hz to 20 kHz, -60 dBFS input, line output mode				
With A-Weighted Filter (RMS)		95	101		dB
No Filter (RMS)		93.5	98		dB
Total Harmonic Distortion + Noise	0 dBFS, 10 k Ω load				
Line Output Mode			-92	-77	dB
Headphone Output Mode			-89	-79	dB
Signal-to-Noise Ratio	Line output mode				
With A-Weighted Filter (RMS)			101		dB
No Filter (RMS)			98		dB
Mute Attenuation					
Mixer 3 and Mixer 4 Muted	MX3RM, MX3LM, MX4RM, MX4LM = 0, MX3AUXG[3:0], MX4AUXG[3:0] = 0000, MX3G1[3:0], MX3G2[3:0] = 0000, MX4G1[3:0], MX4G2[3:0] = 0000		-85	-78	dB
Mixer 5, Mixer 6, and Mixer 7 Muted	MX5G3[1:0], MX5G4[1:0], MX6G3[1:0], MX6G4[1:0], MX7[1:0] = 00		-89	-80	dB
All Volume Controls Muted	LOUTM, ROUTM = 0 MONOM, LHPM, RHPM = 0		-82 -74	-74 -69	dB dB
Interchannel Gain Mismatch		-0.3	-0.005	+0.3	dB
Offset Error		-22	0	+22	mV
Gain Error		-10	+3	+10	%
Interchannel Isolation	1 kHz, 0 dBFS input signal		100		dB
Power Supply Rejection Ratio	CM capacitor = 20 μ F, 100 mV p-p @ 1 kHz		70		dB
DAC TO HEADPHONE/EARPIECE OUTPUT	LOUTx, ROUTx, LHP, RHP in headphone output mode; P _O = output power per channel				
Full-Scale Output Voltage (0 dB)	Scales linearly with AVDD		0.92 (2.60)		V rms (V p-p)
Total Harmonic Distortion + Noise	-4 dBFS, 16 Ω load, P _O = 21.1 mW		-82		dB
	-4 dBFS, 32 Ω load, P _O = 10.6 mW		-82		dB
Capless Headphone Mode	-2 dBFS, 16 Ω load		-78	-71	dB
	-2 dBFS, 32 Ω load		-75	-65	dB
Headphone Output Mode	0 dBFS, 10 k Ω load		-86	-77	dB
Interchannel Isolation	1 kHz, 0 dBFS input signal, 32 Ω load Referred to GND		73		dB
	Referred to CM (capless headphone mode)		50		dB
Power Supply Rejection Ratio	CM capacitor = 20 μ F, 100 mV p-p @ 1 kHz		67		dB
REFERENCE					
Common-Mode Reference Output	CM pin	1.62	1.65	1.67	V

ANALOG PERFORMANCE SPECIFICATIONS, -40°C < T_A < +105°CIOVDD = 3.3 V \pm 10%.

Table 2.

Parameter	Test Conditions/Comments	Min	Typ	Max	Unit
SINGLE-ENDED LINE INPUT					
Dynamic Range	20 Hz to 20 kHz, -60 dB input				
With A-Weighted Filter (RMS)		74			dB
No Filter (RMS)		71			dB
Total Harmonic Distortion + Noise	-1 dBFS			-67	dB

SPECIFICATIONS

Table 2. (Continued)

Parameter	Test Conditions/Comments	Min	Typ	Max	Unit
Input Mixer Gain per Step	-12 dB to +6 dB range	2.88		3.09	dB
Mute Attenuation	LINPG[2:0], LINNG[2:0] = 000, RINPG[2:0], RINNG[2:0] = 000, MX1AUXG[2:0], MX2AUXG[2:0] = 000			-77	dB
Interchannel Gain Mismatch		-0.5		+0.5	dB
Offset Error		-5		+5	mV
Gain Error		-22		-6	%
PSEUDO-DIFFERENTIAL PGA INPUT					
Dynamic Range	20 Hz to 20 kHz, -60 dB input				
With A-Weighted Filter (RMS)		94			dB
No Filter (RMS)		91			dB
Total Harmonic Distortion + Noise	-1 dBFS			-75	dB
PGA Boost Gain Error	20 dB gain setting (RDBOOST[1:0], LDBOOST[1:0] = 10)	-11		-7	dB
Mute Attenuation	PGA muted LDMUTE, RDMUTE = 0 RDBOOST[1:0], LDBOOST[1:0] = 00			-73	dB
Interchannel Gain Mismatch		-0.6		+0.6	dB
Offset Error		-6		+6	mV
Gain Error		-24		-3	%
Common-Mode Rejection Ratio	100 mV rms, 1 kHz	-64		-38	dB
	100 mV rms, 20 kHz	-53		-43	dB
FULL DIFFERENTIAL PGA INPUT					
Dynamic Range	Differential PGA inputs 20 Hz to 20 kHz, -60 dB input				
With A-Weighted Filter (RMS)		89			dB
No Filter (RMS)		86			dB
Total Harmonic Distortion + Noise	-1 dBFS			-70	dB
PGA Boost Gain Error	20 dB gain setting (RDBOOST[1:0], LDBOOST[1:0] = 10)	-11		-7	dB
Mute Attenuation	PGA muted LDMUTE, RDMUTE = 0 RDBOOST[1:0], LDBOOST[1:0] = 00			-73	dB
Interchannel Gain Mismatch		-0.4		+0.4	dB
Offset Error		-6		+6	mV
Gain Error		-21		-7	%
Common-Mode Rejection Ratio	100 mV rms, 1 kHz	-64		-38	dB
	100 mV rms, 20 kHz	-53		-43	dB
MICROPHONE BIAS					
Bias Voltage	MBIEN = 1				
0.65 × AVDD	MBI = 1, MPERF = 0	1.85		2.45	V
	MBI = 1, MPERF = 1	1.87		2.45	V
0.90 × AVDD	MBI = 0, MPERF = 0	2.65		3.40	V
	MBI = 0, MPERF = 1	2.65		3.40	V
Noise in the Signal Bandwidth	1 kHz to 20 kHz	11		36	nV/√Hz
DAC TO LINE OUTPUT					
Dynamic Range	20 Hz to 20 kHz, -60 dB input, line output mode				
With A-Weighted Filter (RMS)		85			dB
No Filter (RMS)		78			dB

SPECIFICATIONS

Table 2. (Continued)

Parameter	Test Conditions/Comments	Min	Typ	Max	Unit
Total Harmonic Distortion + Noise	0 dBFS, 10 k Ω load				
Line Output Mode				-76	dB
Headphone Output Mode				-78	dB
Mute Attenuation					
Mixer 3 and Mixer 4 Muted	MX3RM, MX3LM, MX4RM, MX4LM = 0, MX3AUXG[3:0], MX4AUXG[3:0] = 0000, MX3G1[3:0], MX3G2[3:0] = 0000, MX4G1[3:0], MX4G2[3:0] = 0000			-77	dB
Mixer 5, Mixer 6, and Mixer 7 Muted	MX5G3[1:0], MX5G4[1:0], MX6G3[1:0], MX6G4[1:0], MX7[1:0] = 00			-77	dB
All Volume Controls Muted	LOUTM, ROUTM = 0 MONOM, LHPM, RHPM = 0			-74	dB
Interchannel Gain Mismatch		-0.3		+0.3	dB
Offset Error		-22		+22	mV
Gain Error		-10		+10	%
DAC TO HEADPHONE/EARPIECE OUTPUT	LOUTx, ROUTx, LHP, RHP in headphone output mode; P _O = output power per channel				
Total Harmonic Distortion + Noise					
Capless Headphone Mode	-2 dBFS, 16 Ω load			-61	dB
Headphone Output Mode	-2 dBFS, 32 Ω load			-63	dB
Headphone Output Mode	0 dBFS, 10 k Ω load			-76	dB
REFERENCE					
Common-Mode Reference Output	CM pin	1.47		1.83	V

POWER SUPPLY SPECIFICATIONS

Main clock = 12.288 MHz, input sample rate = 48 kHz, input tone = 1 kHz, ADC input @ -1 dBFS, DAC input @ 0 dBFS, -40°C < T_A < +105°C, IOVDD = 3.3 V \pm 10%. For total power consumption, add the IOVDD current listed in Table 3.

Table 3.

Parameter	Test Conditions/Comments	Min	Typ	Max	Unit
SUPPLIES					
Voltage	DVDDOUT		1.56		V
	AVDD	2.97	3.3	3.65	V
	IOVDD	2.97	3.3	3.65	V
Digital I/O Current (IOVDD)	20 pF capacitive load on all digital pins				
Subordinate Mode	f _S = 48 kHz		0.48		mA
	f _S = 96 kHz		0.9		mA
Main Mode	f _S = 8 kHz		0.13		mA
	f _S = 48 kHz		1.51		mA
	f _S = 96 kHz		3		mA
	f _S = 8 kHz		0.27		mA
Analog Current (AVDD)					
Record Stereo Differential to ADC	PLL bypass		5.24		mA
	Integer PLL		6.57		mA
DAC Stereo Playback to Line Output	10 k Ω load				
	PLL bypass		5.55		mA
	Integer PLL		6.90		mA
DAC Stereo Playback to Headphone	32 Ω load				

SPECIFICATIONS

Table 3. (Continued)

Parameter	Test Conditions/Comments	Min	Typ	Max	Unit
DAC Stereo Playback to Capless Headphone	PLL bypass		30.9		mA
	Integer PLL		32.25		mA
	32 Ω load				
	PLL bypass		56.75		mA
	Integer PLL		58		mA

DIGITAL FILTERS

Table 4.

Parameter	Mode	Factor	Min	Typ	Max	Unit
ADC DECIMATION FILTER	All modes, typ @ 48 kHz					
Pass Band		$0.4375 f_S$		21		kHz
Pass-Band Ripple				± 0.015		dB
Transition Band		$0.5 f_S$		24		kHz
Stop Band		$0.5625 f_S$		27		kHz
Stop-Band Attenuation				67		dB
Group Delay		$22.9844/f_S$		479		μs
DAC INTERPOLATION FILTER						
Pass Band	48 kHz mode, typ @ 48 kHz	$0.4535 f_S$		22		kHz
	96 kHz mode, typ @ 96 kHz	$0.3646 f_S$		35		kHz
Pass-Band Ripple	48 kHz mode, typ @ 48 kHz				± 0.01	dB
	96 kHz mode, typ @ 96 kHz				± 0.05	dB
Transition Band	48 kHz mode, typ @ 48 kHz	$0.5 f_S$		24		kHz
	96 kHz mode, typ @ 96 kHz	$0.5 f_S$		48		kHz
Stop Band	48 kHz mode, typ @ 48 kHz	$0.5465 f_S$		26		kHz
	96 kHz mode, typ @ 96 kHz	$0.6354 f_S$		61		kHz
Stop-Band Attenuation	48 kHz mode, typ @ 48 kHz			69		dB
	96 kHz mode, typ @ 96 kHz			68		dB
Group Delay	48 kHz mode, typ @ 48 kHz	$25/f_S$		521		μs
	96 kHz mode, typ @ 96 kHz	$11/f_S$		115		μs

DIGITAL INPUT/OUTPUT SPECIFICATIONS

$-40^{\circ}\text{C} < T_A < +105^{\circ}\text{C}$, IOVDD = 3.3 V \pm 10%.

Table 5.

Parameter	Test Conditions/Comments	Min	Typ	Max	Unit
INPUT SPECIFICATIONS					
Input Voltage High (V_{IH})		$0.7 \times \text{IOVDD}$			V
Input Voltage Low (V_{IL})				$0.3 \times \text{IOVDD}$	V
Input Leakage					
Pull-Ups/Pull-Downs Disabled	$I_{IH} @ V_{IH} = 3.3 \text{ V}$	-0.17		+0.17	μA
	$I_{IL} @ V_{IL} = 0 \text{ V}$	-0.17		+0.17	μA
	$I_{IL} @ V_{IL} = 0 \text{ V (MCLK pin)}$	-13.5		-0.5	μA
Pull-Ups Enabled	$I_{IH} @ V_{IH} = 3.3 \text{ V}$	-0.7		+0.7	μA
	$I_{IL} @ V_{IL} = 0 \text{ V}$	-13.5		-0.5	μA
Pull-Downs Enabled	$I_{IH} @ V_{IH} = 3.3 \text{ V}$	2.7		8.3	μA
	$I_{IL} @ V_{IL} = 0 \text{ V}$	-0.18		+0.18	μA
Input Capacitance				5	pF

SPECIFICATIONS

Table 5. (Continued)

Parameter	Test Conditions/Comments	Min	Typ	Max	Unit
OUTPUT SPECIFICATIONS					
Output Voltage High (V_{OH})	$I_{OH} = 2 \text{ mA @ } 3.3 \text{ V}$	$0.8 \times IOVDD$			V
Output Voltage Low (V_{OL})	$I_{OL} = 2 \text{ mA @ } 3.3 \text{ V}$			$0.1 \times IOVDD$	V

DIGITAL TIMING SPECIFICATIONS

$-40^{\circ}\text{C} < T_A < +105^{\circ}\text{C}$, $IOVDD = 3.3 \text{ V} \pm 10\%$.

Table 6. Digital Timing

Parameter	Limit		Unit	Description
	t_{MIN}	t_{MAX}		
MAIN CLOCK				
t_{MP}	74	488	ns	MCLK period, $256 \times f_S$ mode.
t_{MP}	37	244	ns	MCLK period, $512 \times f_S$ mode.
t_{MP}	24.7	162.7	ns	MCLK period, $768 \times f_S$ mode.
t_{MP}	18.5	122	ns	MCLK period, $1024 \times f_S$ mode.
SERIAL PORT				
t_{BIL}	5		ns	BCLK pulse width low.
t_{BIH}	5		ns	BCLK pulse width high.
t_{LIS}	5		ns	LRCLK setup. Time to BCLK rising.
t_{LIH}	5		ns	LRCLK hold. Time from BCLK rising.
t_{SIS}	5		ns	DAC_SDATA setup. Time to BCLK rising.
t_{SIH}	5		ns	DAC_SDATA hold. Time from BCLK rising.
t_{SODM}		50	ns	ADC_SDATA delay. Time from BCLK falling in main mode.
SPI PORT				
f_{CCLK}		10	MHz	CCLK frequency.
t_{CCPL}	10		ns	CCLK pulse width low.
t_{CCPH}	10		ns	CCLK pulse width high.
t_{CLS}	5		ns	$\overline{\text{CLATCH}}$ setup. Time to CCLK rising.
t_{CLH}	10		ns	$\overline{\text{CLATCH}}$ hold. Time from CCLK rising.
t_{CLPH}	10		ns	$\overline{\text{CLATCH}}$ pulse width high.
t_{CDS}	5		ns	CDATA setup. Time to CCLK rising.
t_{CDH}	5		ns	CDATA hold. Time from CCLK rising.
t_{COD}		50	ns	COOUT three-stated. Time from $\overline{\text{CLATCH}}$ rising.
I ² C PORT				
f_{SCL}		400	kHz	SCL frequency.
t_{SCLH}	0.6		μs	SCL high.
t_{SCLL}	1.3		μs	SCL low.
t_{SCS}	0.6		μs	Setup time; relevant for repeated start condition.
t_{SCH}	0.6		μs	Hold time. After this period, the first clock is generated.
t_{DS}	100		ns	Data setup time.
t_{SCR}		300	ns	SCL rise time.
t_{SCF}		300	ns	SCL fall time.
t_{SDR}		300	ns	SDA rise time.
t_{SDF}		300	ns	SDA fall time.
t_{BFT}	0.6		μs	Bus-free time. Time between stop and start.
DIGITAL MICROPHONE				
t_{DCF}		10	ns	$R_{LOAD} = 1 \text{ M}\Omega$, $C_{LOAD} = 14 \text{ pF}$. Digital microphone clock fall time.
t_{DCR}		10	ns	Digital microphone clock rise time.

SPECIFICATIONS

Table 6. Digital Timing (Continued)

Parameter	Limit		Unit	Description
	t_{MIN}	t_{MAX}		
t_{DDV}	22	30	ns	Digital microphone delay time for valid data.
t_{DDH}	0	12	ns	Digital microphone delay time for data three-stated.

DIGITAL TIMING DIAGRAMS

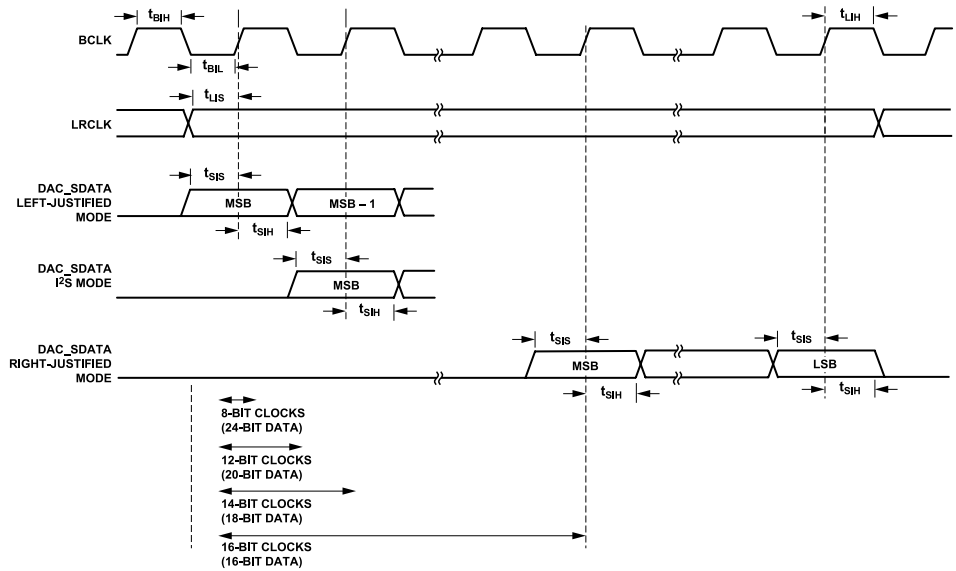

Figure 2. Serial Input Port Timing

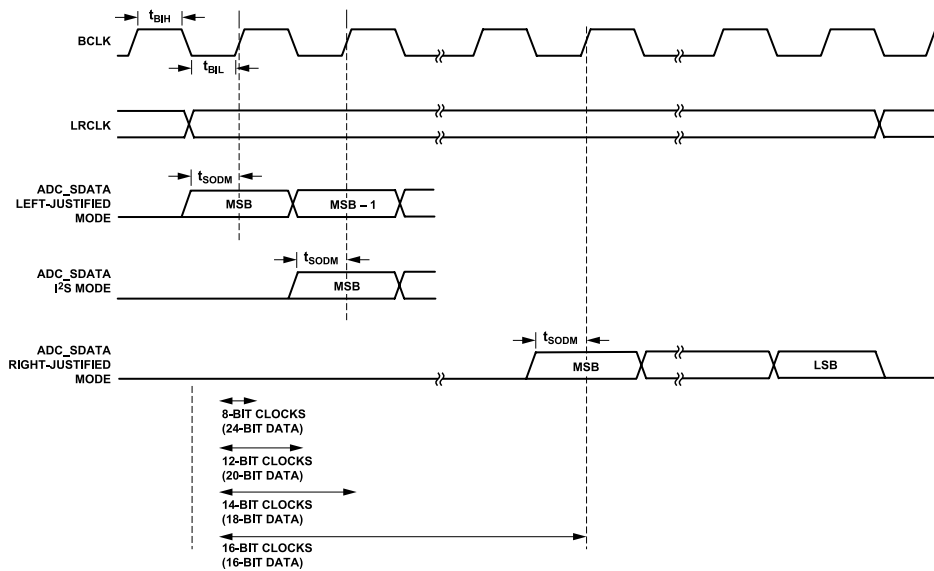

Figure 3. Serial Output Port Timing

SPECIFICATIONS

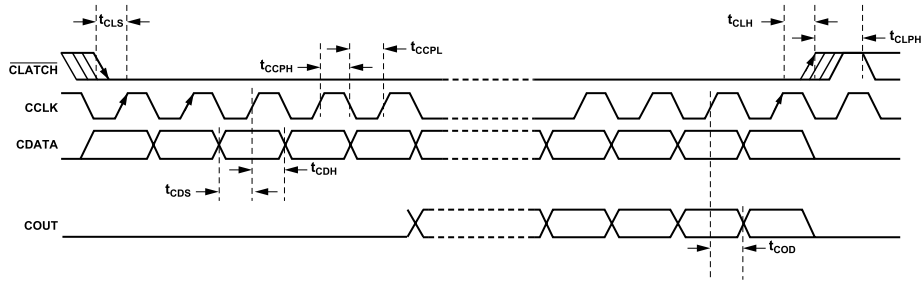

Figure 4. SPI Port Timing

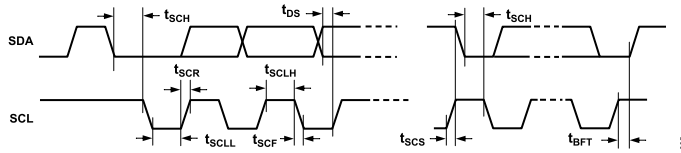

Figure 5. I²C Port Timing

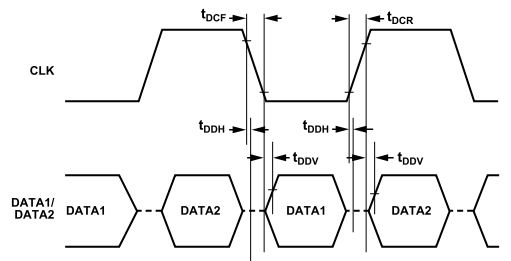

Figure 6. Digital Microphone Timing

ABSOLUTE MAXIMUM RATINGS

Table 7.

Parameter	Rating
Power Supply (AVDD)	-0.3 V to +3.65 V
Input Current (Except Supply Pins)	±20 mA
Analog Input Voltage (Signal Pins)	-0.3 V to AVDD + 0.3 V
Digital Input Voltage (Signal Pins)	-0.3 V to IOVDD + 0.3 V
Operating Temperature Range	-40°C to +105°C
Storage Temperature Range	-65°C to +150°C
Maximum Junction Temperature	125°C

Stresses at or above those listed under Absolute Maximum Ratings may cause permanent damage to the product. This is a stress rating only; functional operation of the product at these or any other conditions above those indicated in the operational section of this specification is not implied. Operation beyond the maximum operating conditions for extended periods may affect product reliability.

THERMAL RESISTANCE

θ_{JA} represents thermal resistance, junction-to-ambient; θ_{JC} represents thermal resistance, junction-to-case. All characteristics are for a 4-layer board.

Table 8. Thermal Resistance

Package Type	θ_{JA}	θ_{JC}	Unit
32-Lead LFCSP	50.1	17	°C/W

ESD CAUTION



ESD (electrostatic discharge) sensitive device. Charged devices and circuit boards can discharge without detection. Although this product features patented or proprietary protection circuitry, damage may occur on devices subjected to high energy ESD. Therefore, proper ESD precautions should be taken to avoid performance degradation or loss of functionality.

PIN CONFIGURATION AND FUNCTION DESCRIPTIONS

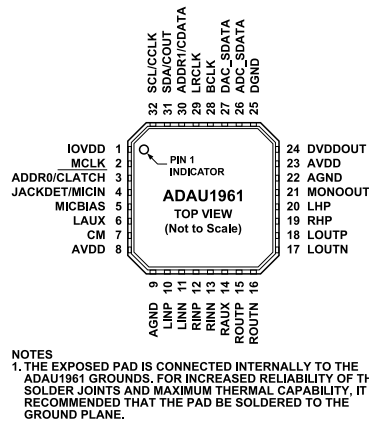

Figure 7. Pin Configuration

Table 9. Pin Function Descriptions

Pin No.	Mnemonic	Type ¹	Description
1	IOVDD	PWR	Supply for Digital Input and Output Pins. The digital output pins are supplied from IOVDD, which also sets the highest input voltage that should be seen on the digital input pins. IOVDD should be set to 3.3 V. The current draw of this pin is variable because it is dependent on the loads of the digital outputs. IOVDD should be decoupled to DGND with a 100 nF capacitor and a 10 μ F capacitor.
2	MCLK	D_IN	External Main Clock Input.
3	ADDR0/CLATCH	D_IN	I ² C Address Bit 0 (ADDR0). SPI Latch Signal (CLATCH). Must go low at the beginning of an SPI transaction and high at the end of a transaction. Each SPI transaction can take a different number of CCLKs to complete, depending on the address and read/write bit that are sent at the beginning of the SPI transaction.
4	JACKDET/MICIN	D_IN	Detect Insertion/Removal of Headphone Plug (JACKDET). Digital Microphone Stereo Input (MICIN).
5	MICBIAS	A_OUT	Bias Voltage for Electret Microphone.
6	LAUX	A_IN	Left Channel Single-Ended Auxiliary Input. Biased at AVDD/2.
7	CM	A_OUT	AVDD/2 V Common-Mode Reference. A 10 μ F to 47 μ F standard decoupling capacitor should be connected between this pin and AGND to reduce crosstalk between the ADCs and DACs. This pin can be used to bias external analog circuits, as long as they are not drawing current from CM (for example, the noninverting input of an op amp).
8	AVDD	PWR	3.3 V Analog Supply for DAC and Microphone Bias. This pin should be decoupled locally to AGND with a 100 nF capacitor.
9	AGND	PWR	Analog Ground. The AGND and DGND pins can be tied together on a common ground plane. AGND should be decoupled locally to AVDD with a 100 nF capacitor.
10	LINP	A_IN	Left Channel Noninverting Input or Single-Ended Input 0. Biased at AVDD/2.
11	LINN	A_IN	Left Channel Inverting Input or Single-Ended Input 1. Biased at AVDD/2.
12	RINP	A_IN	Right Channel Noninverting Input or Single-Ended Input 2. Biased at AVDD/2.
13	RINN	A_IN	Right Channel Inverting Input or Single-Ended Input 3. Biased at AVDD/2.
14	RAUX	A_IN	Right Channel Single-Ended Auxiliary Input. Biased at AVDD/2.
15	ROU TP	A_OUT	Right Line Output, Positive. Biased at AVDD/2.
16	ROUTN	A_OUT	Right Line Output, Negative. Biased at AVDD/2.
17	LOUTN	A_OUT	Left Line Output, Negative. Biased at AVDD/2.
18	LOU TP	A_OUT	Left Line Output, Positive. Biased at AVDD/2.
19	RHP	A_OUT	Right Headphone Output. Biased at AVDD/2.
20	LHP	A_OUT	Left Headphone Output. Biased at AVDD/2.
21	MONOOUT	A_OUT	Mono Output or Virtual Ground for Capless Headphone. Biased at AVDD/2 when set as mono output.
22	AGND	PWR	Analog Ground. The AGND and DGND pins can be tied together on a common ground plane. AGND should be decoupled locally to AVDD with a 100 nF capacitor.

PIN CONFIGURATION AND FUNCTION DESCRIPTIONS

Table 9. Pin Function Descriptions (Continued)

Pin No.	Mnemonic	Type ¹	Description
23	AVDD	PWR	3.3 V Analog Supply for ADC, Output Driver, and Input to Digital Supply Regulator. This pin should be decoupled locally to AGND with a 100 nF capacitor.
24	DVDDOUT	PWR	Digital Core Supply Decoupling Point. The digital supply is generated from an on-board regulator and does not require an external supply. DVDDOUT should be decoupled to DGND with a 100 nF capacitor and a 10 μ F capacitor.
25	DGND	PWR	Digital Ground. The AGND and DGND pins can be tied together on a common ground plane. DGND should be decoupled to DVDDOUT and to IOVDD with 100 nF capacitors and 10 μ F capacitors.
26	ADC_SDATA	D_OUT	ADC Serial Output Data.
27	DAC_SDATA	D_IN	DAC Serial Input Data.
28	BCLK	D_IO	Serial Data Port Bit Clock.
29	LRCLK	D_IO	Serial Data Port Frame Clock.
30	ADDR1/CDATA	D_IN	I ² C Address Bit 1 (ADDR1). SPI Data Input (CDATA).
31	SDA/COUT	D_IO	I ² C Data (SDA). This pin is a bidirectional open-collector input/output. The line connected to this pin should have a 2 k Ω pull-up resistor. SPI Data Output (COUT). This pin is used for reading back registers and memory locations. It is three-state when an SPI read is not active.
32	SCL/CCLK	D_IN	I ² C Clock (SCL). This pin is always an open-collector input when in I ² C control mode. The line connected to this pin should have a 2 k Ω pull-up resistor. SPI Clock (CCLK). This pin can run continuously or be gated off between SPI transactions.
EP	Exposed Pad		Exposed Pad. The exposed pad is connected internally to the ADAU1961 grounds. For increased reliability of the solder joints and maximum thermal capability, it is recommended that the pad be soldered to the ground plane. See the Exposed Pad PCB Design section for more information.

¹ A_IN = analog input, A_OUT = analog output, D_IN = digital input, D_IO = digital input/output, D_OUT = digital output, PWR = power.

TYPICAL PERFORMANCE CHARACTERISTICS

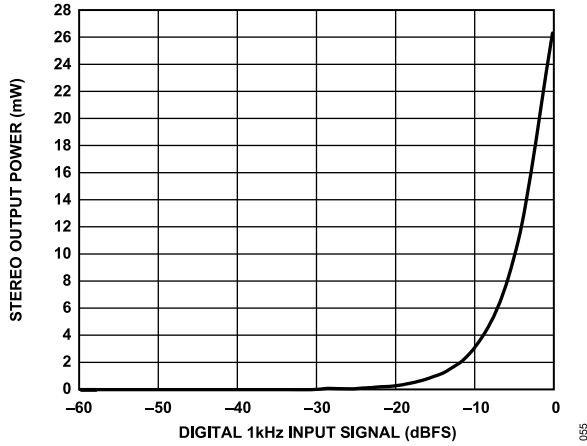

Figure 8. Headphone Amplifier Power vs. Input Level, 16 Ω Load

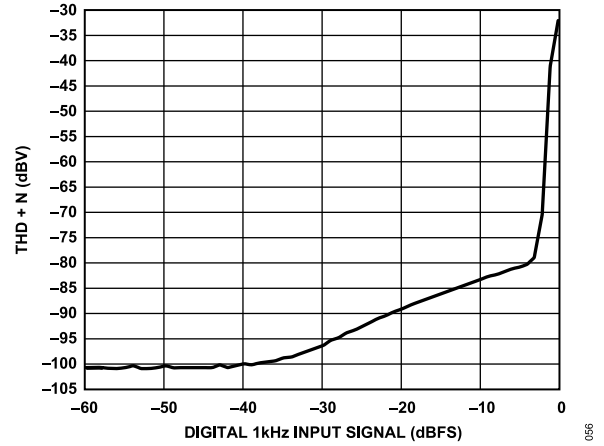

Figure 11. Headphone Amplifier THD + N vs. Input Level, 16 Ω Load

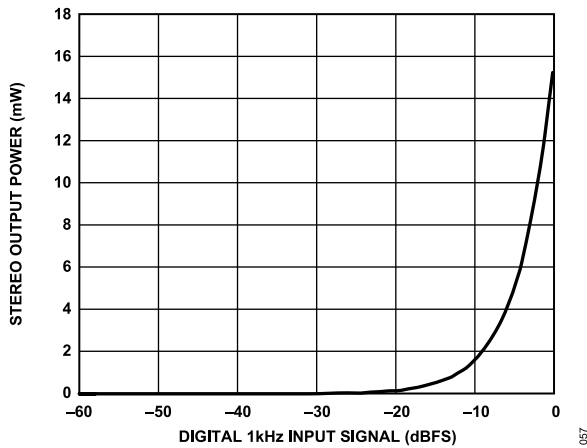

Figure 9. Headphone Amplifier Power vs. Input Level, 32 Ω Load

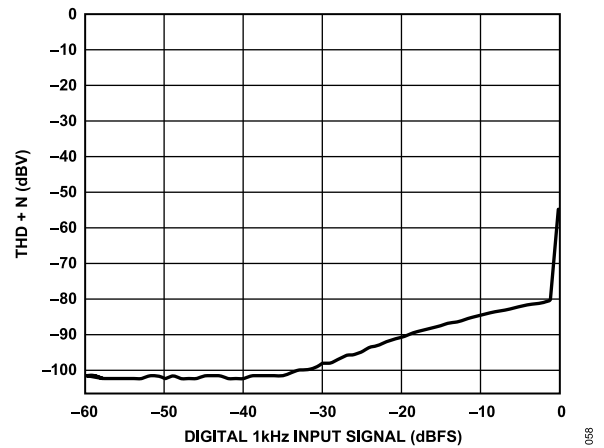

Figure 12. Headphone Amplifier THD + N vs. Input Level, 32 Ω Load

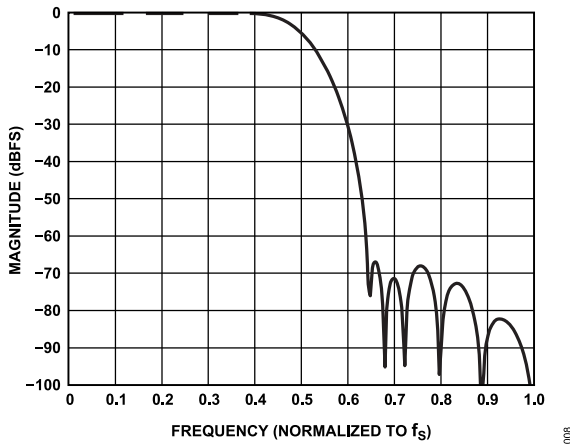

Figure 10. ADC Decimation Filter, 64× Oversampling, Normalized to f_s

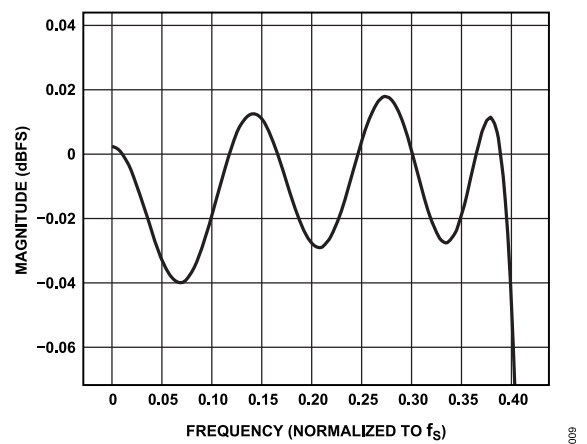

Figure 13. ADC Decimation Filter Pass-Band Ripple, 64× Oversampling, Normalized to f_s

TYPICAL PERFORMANCE CHARACTERISTICS

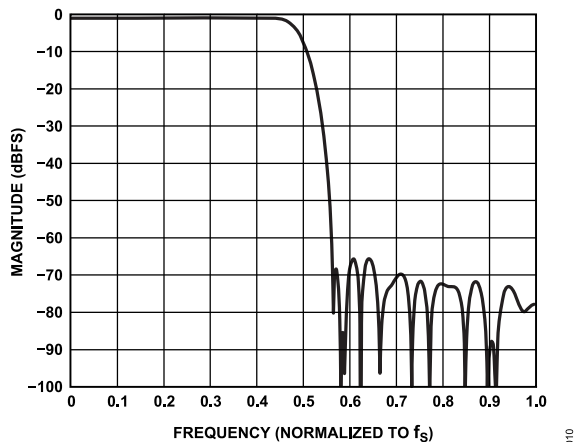

Figure 14. ADC Decimation Filter, 128× Oversampling, Normalized to f_s

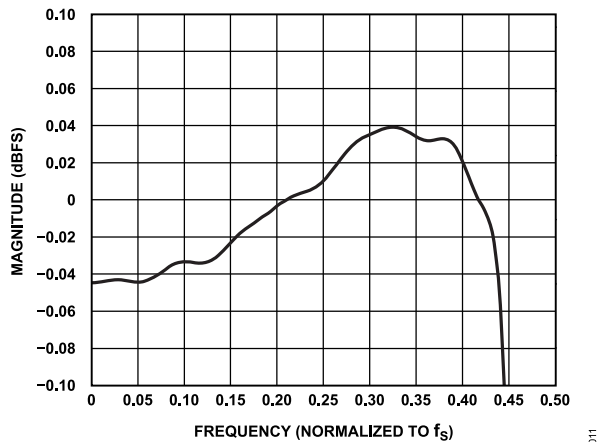

Figure 17. ADC Decimation Filter Pass-Band Ripple, 128× Oversampling, Normalized to f_s

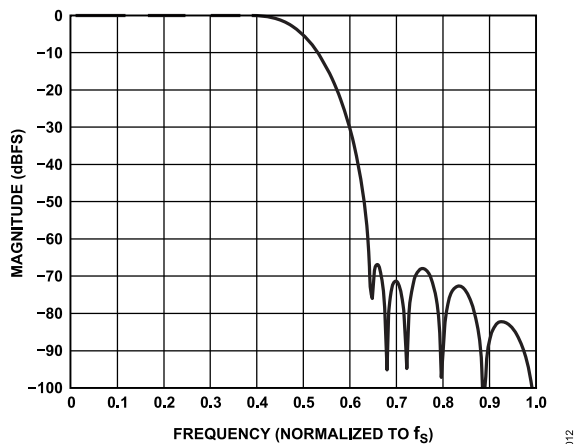

Figure 15. ADC Decimation Filter, 128× Oversampling, Double-Rate Mode, Normalized to f_s

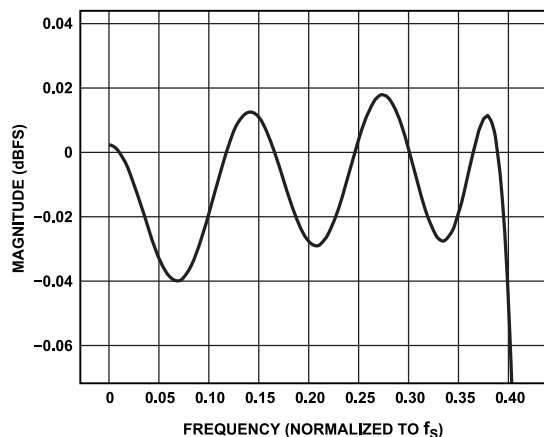

Figure 18. ADC Decimation Filter Pass-Band Ripple, 128× Oversampling, Double-Rate Mode, Normalized to f_s

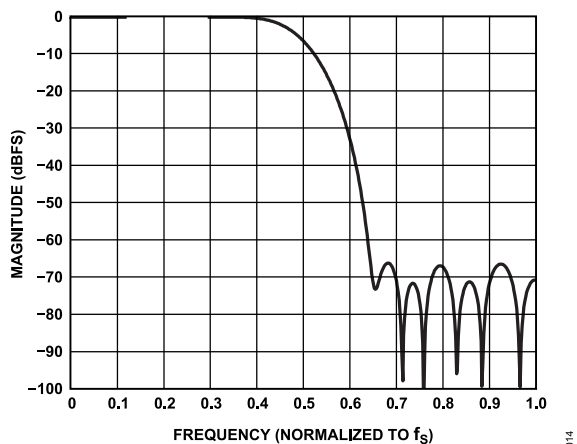

Figure 16. DAC Interpolation Filter, 64× Oversampling, Double-Rate Mode, Normalized to f_s

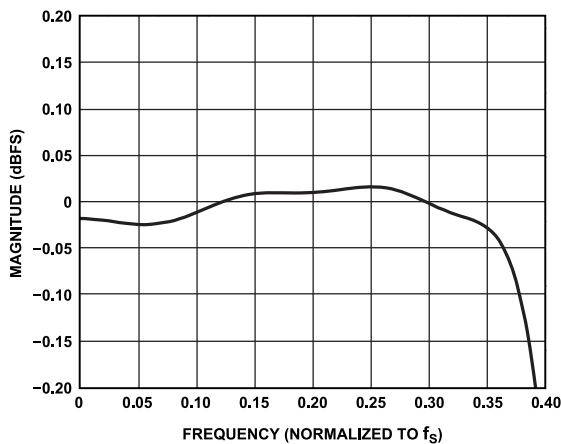

Figure 19. DAC Interpolation Filter Pass-Band Ripple, 64× Oversampling, Double-Rate Mode, Normalized to f_s

TYPICAL PERFORMANCE CHARACTERISTICS

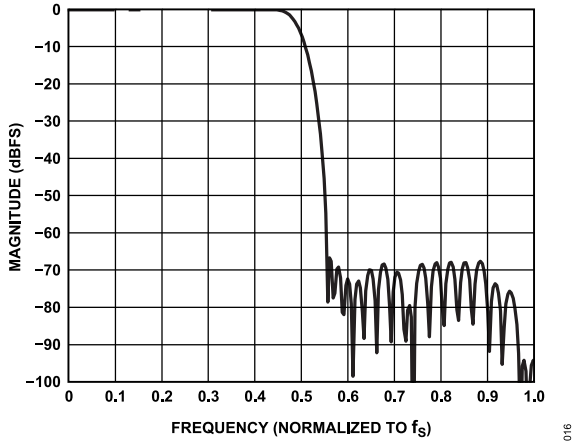

Figure 20. DAC Interpolation Filter, 128x Oversampling, Normalized to f_s

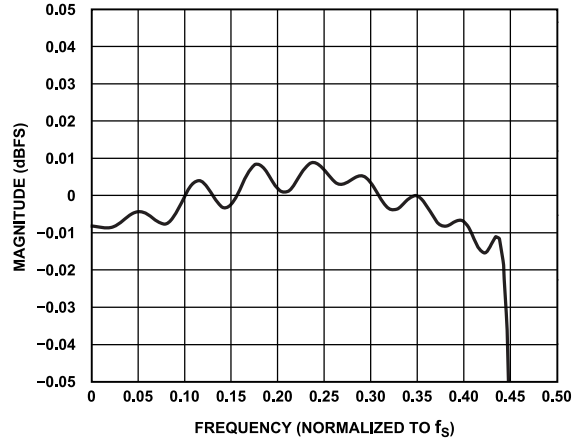

Figure 23. DAC Interpolation Filter Pass-Band Ripple, 128x Oversampling, Normalized to f_s

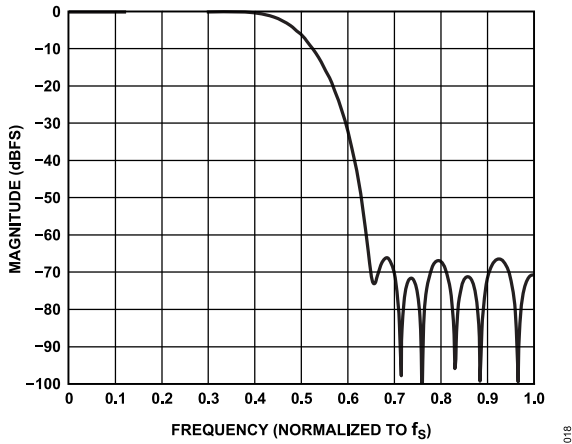

Figure 21. DAC Interpolation Filter, 128x Oversampling, Double-Rate Mode, Normalized to f_s

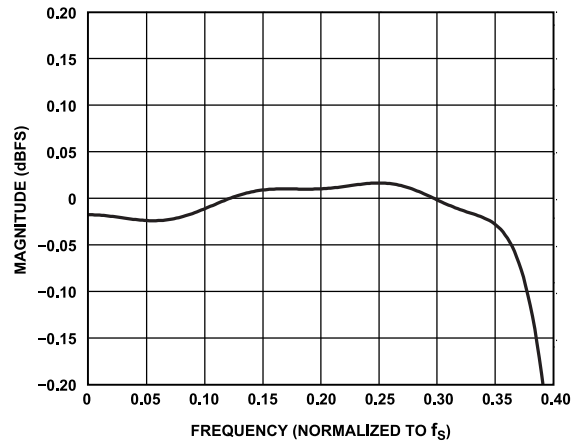

Figure 24. DAC Interpolation Filter Pass-Band Ripple, 128x Oversampling, Double-Rate Mode, Normalized to f_s

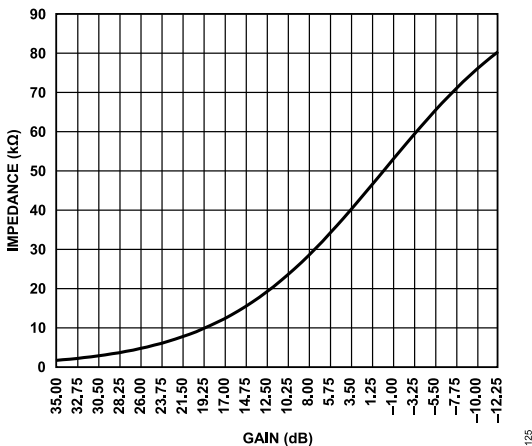

Figure 22. Input Impedance vs. Gain for Analog Inputs

SYSTEM BLOCK DIAGRAMS

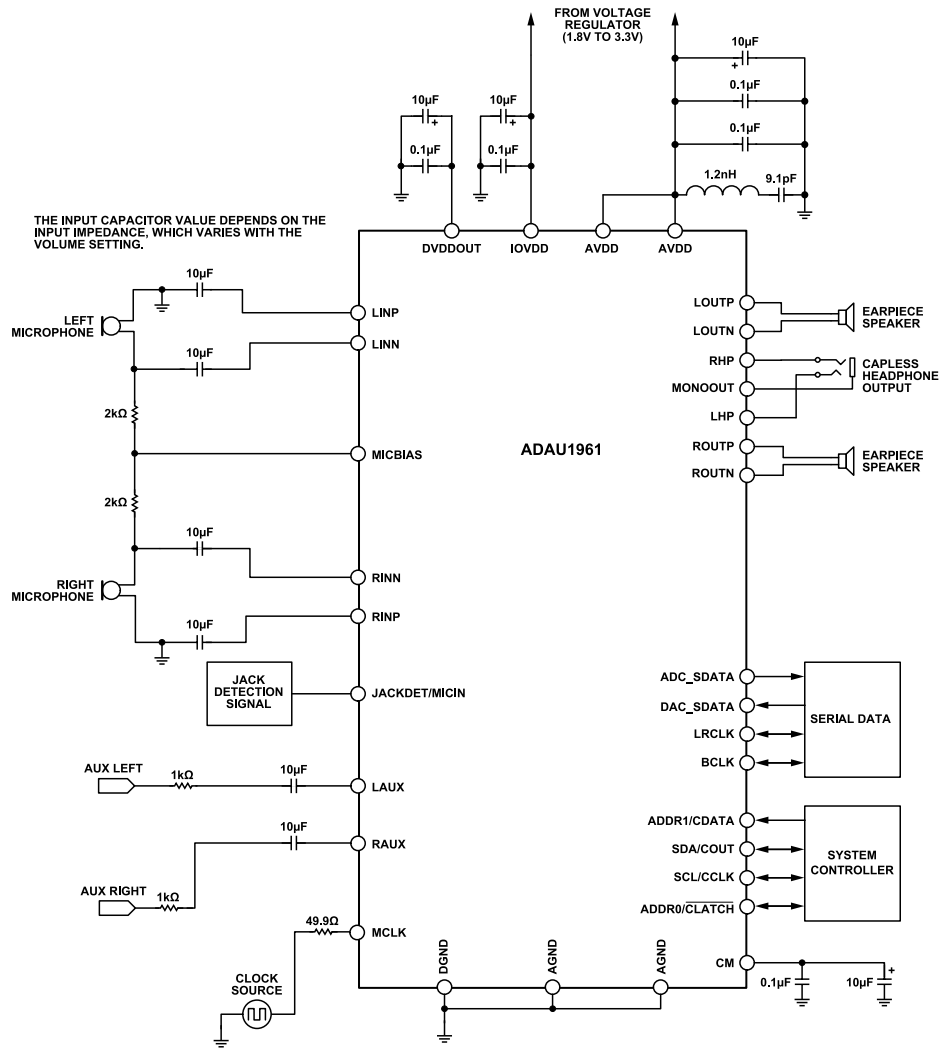

Figure 25. System Block Diagram

045

SYSTEM BLOCK DIAGRAMS

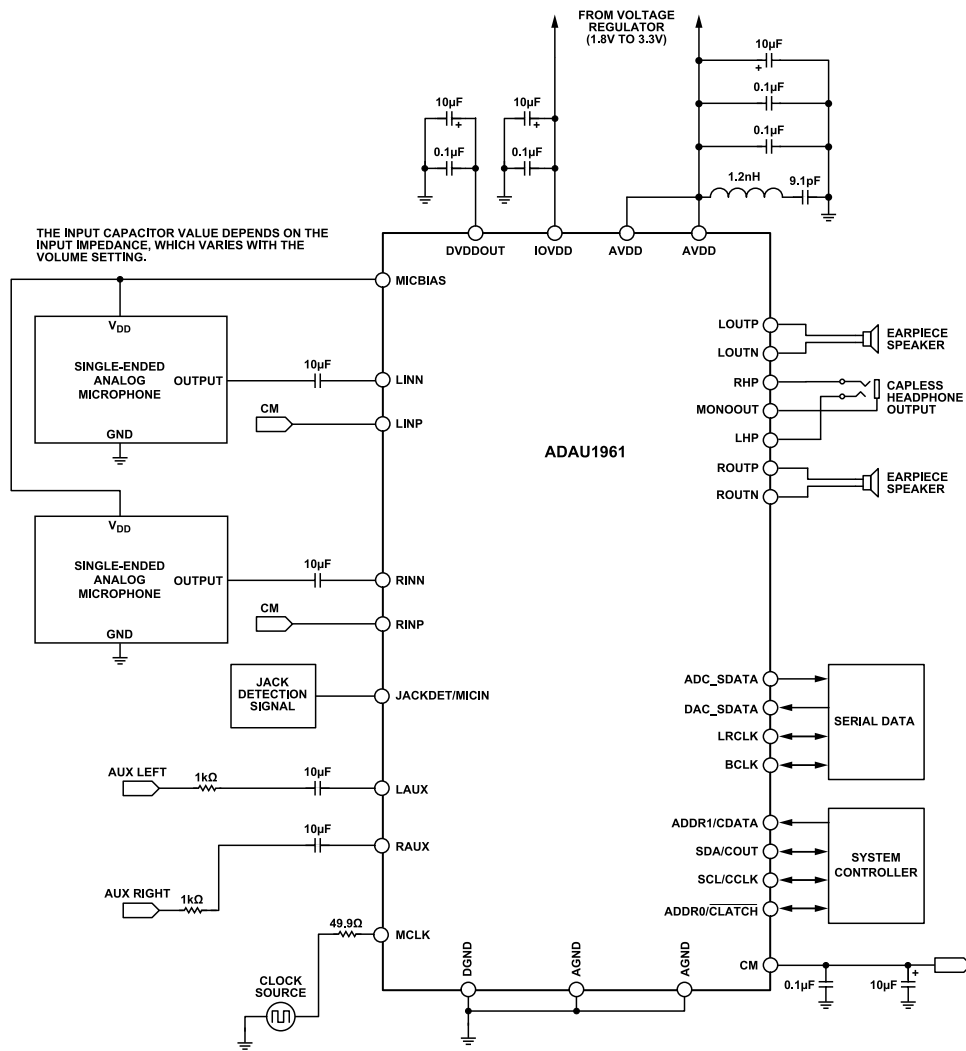

Figure 26. System Block Diagram with Analog Microphones

SYSTEM BLOCK DIAGRAMS

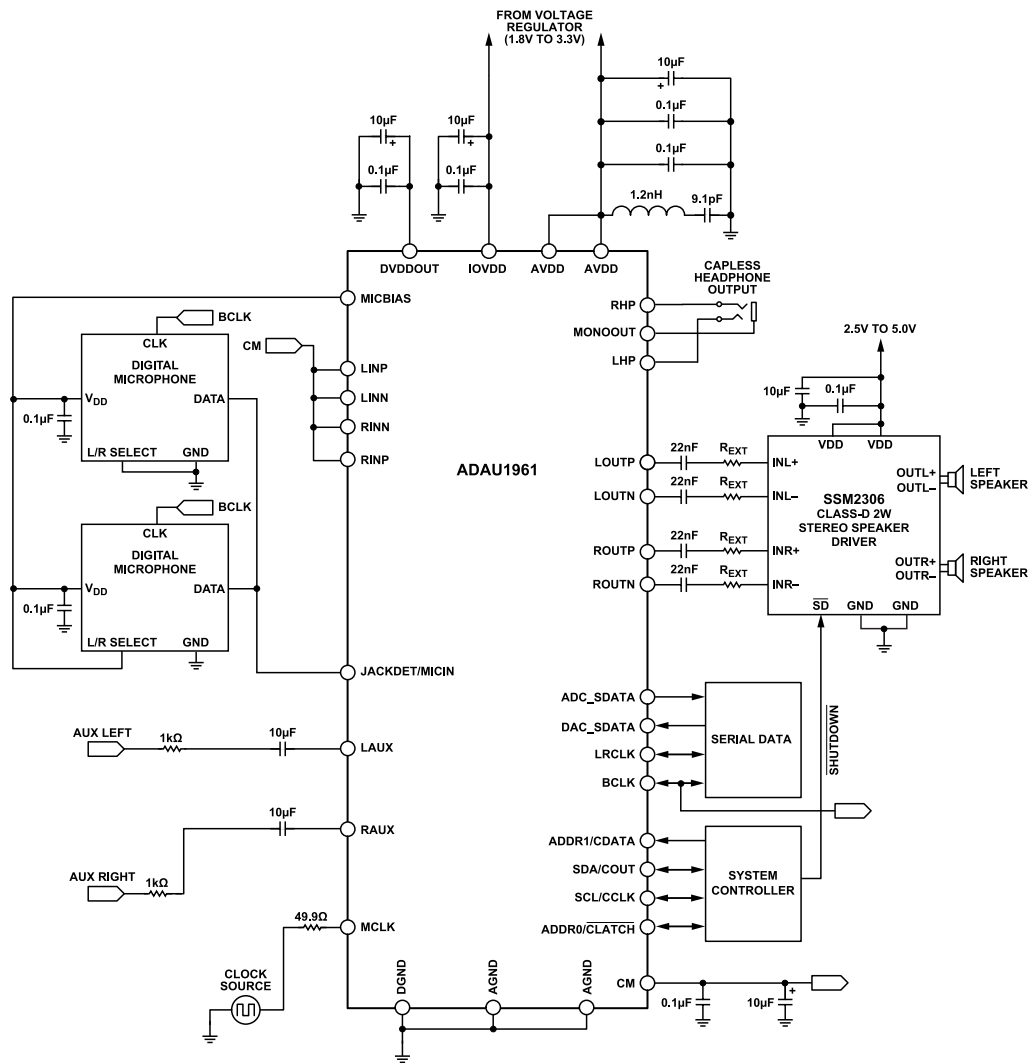

Figure 27. System Block Diagram with Digital Microphones and SSM2306 Class-D Speaker Driver

THEORY OF OPERATION

The ADAU1961 is a low power audio codec that offers high quality audio, low power, small size, and many advanced features. The stereo ADC and stereo DAC each have an SNR of at least +98 dB and a THD + N of at least -90 dB. The serial data port is compatible with I²S, left-justified, right-justified, and TDM modes for interfacing to digital audio data. The operating voltage is 3.3 V, with an on-board regulator generating the internal digital supply voltage.

The record signal path includes very flexible input configurations that can accept differential and single-ended analog microphone inputs as well as a digital microphone input. A microphone bias pin provides seamless interfacing to electret microphones. Input configurations can accept up to six single-ended analog signals or variations of stereo differential or stereo single-ended signals with two additional auxiliary single-ended inputs. Each input signal has its own programmable gain amplifier (PGA) for volume adjustment and can be routed directly to the playback path output mixers, bypassing the ADCs. An automatic level control (ALC) can also be implemented to keep the recording volume constant.

The ADCs and DACs are high quality, 24-bit Σ - Δ converters that operate at selectable 64 \times or 128 \times oversampling ratios. The base

sampling rate of the converters is set by the input clock rate and can be further scaled with the converter control register settings. The converters can operate at sampling frequencies from 8 kHz to 96 kHz. The ADCs and DACs also include very fine-step digital volume controls.

The playback path allows input signals and DAC outputs to be mixed into various output configurations. Headphone drivers are available for a stereo headphone output, and the other output pins are capable of differentially driving an earpiece speaker. Capless headphone outputs are possible with the use of the mono output as a virtual ground connection. The stereo line outputs can be used as either single-ended or differential outputs and as an optional mix-down mono output.

The ADAU1961 can generate its internal clocks from a wide range of input clocks by using the on-board fractional PLL. The PLL accepts inputs from 8 MHz to 27 MHz.

The ADAU1961 is provided in a small, 32-lead, 5 mm \times 5 mm LFCSP with an exposed bottom pad.

STARTUP, INITIALIZATION, AND POWER

This section describes the procedure for properly starting up the ADAU1961. The following sequence provides a high level approach to the proper initiation of the system.

1. Apply power to the ADAU1961.
2. Lock the PLL to the input clock (if using the PLL).
3. Enable the core clock.
4. Load the register settings.

POWER-UP SEQUENCE

The ADAU1961 uses a power-on reset (POR) circuit to reset the registers upon power-up. The POR monitors the DVDDOUT pin and generates a reset signal whenever power is applied to the chip. During the reset, the ADAU1961 is set to the default values documented in the register map (see the [Control Registers](#) section). Typically, with a 10 μ F capacitor on AVDD, the POR takes approximately 14 ms.

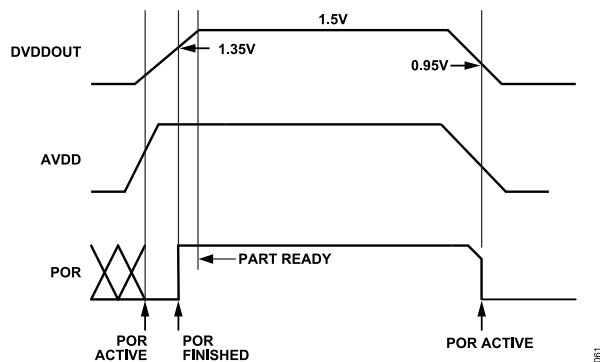

Figure 28. Power-On Reset Sequence

The PLL lock time is dependent on the MCLK rate. Typical lock times are provided in [Table 10](#).

Table 10. PLL Lock Times

PLL Mode	MCLK Frequency	Lock Time (Typical)
Fractional	8 MHz	3.5 ms
Fractional	12 MHz	3.0 ms
Integer	12.288 MHz	2.96 ms
Fractional	13 MHz	2.4 ms
Fractional	14.4 MHz	2.4 ms
Fractional	19.2 MHz	2.98 ms
Fractional	19.68 MHz	2.98 ms
Fractional	19.8 MHz	2.98 ms
Fractional	24 MHz	2.95 ms
Integer	24.576 MHz	2.96 ms
Fractional	26 MHz	2.4 ms
Fractional	27 MHz	2.4 ms

POWER REDUCTION MODES

Sections of the ADAU1961 chip can be turned on and off as needed to reduce power consumption. These include the ADCs, the DACs, and the PLL.

The digital filters of the ADCs and DACs can each be set to oversampling ratios of 64 \times or 128 \times (default). Setting the oversampling ratios to 64 \times for these filters lowers power consumption with a minimal impact on performance. See the [Digital Filters](#) section for specifications; see the [Typical Performance Characteristics](#) section for graphs of these filters.

DIGITAL POWER SUPPLY

The digital power supply for the ADAU1961 is generated from an internal regulator. This regulator generates a 1.5 V supply internally. The only external connection to this regulator is the DVDDOUT bypassing point. A 100 nF capacitor and a 10 μ F capacitor should be connected between this pin and DGND.

INPUT/OUTPUT POWER SUPPLY

The power for the digital output pins is supplied from IOVDD, and this pin also sets the highest input voltage that should be seen on the digital input pins. IOVDD should be set to 3.3 V; no digital input signal should be at a voltage level higher than the one on IOVDD. The current draw of this pin is variable because it depends on the loads of the digital outputs. IOVDD should be decoupled to DGND with a 100 nF capacitor and a 10 μ F capacitor.

CLOCK GENERATION AND MANAGEMENT

The ADAU1961 uses a flexible clocking scheme that enables the use of many different input clock rates. The PLL can be bypassed or used, resulting in two different approaches to clock management. For more information about clocking schemes, PLL configuration, and sampling rates, see the [Clocking and Sampling Rates](#) section.

Case 1: PLL Is Bypassed

If the PLL is bypassed, the core clock is derived directly from the MCLK input. The rate of this clock must be set properly in Register R0 (clock control register, Address 0x4000) using the INFREQ[1:0] bits. When the PLL is bypassed, supported external clock rates are $256 \times f_S$, $512 \times f_S$, $768 \times f_S$, and $1024 \times f_S$, where f_S is the base sampling rate. The core clock of the chip is off until the core clock enable bit (COREN) is asserted.

Case 2: PLL Is Used

The core clock to the entire chip is off during the PLL lock acquisition period. The user can poll the lock bit to determine when the PLL has locked. After lock is acquired, the ADAU1961 can be started by asserting the core clock enable bit (COREN) in Register R0 (clock control register, Address 0x4000). This bit enables the core clock to all the internal blocks of the ADAU1961.

PLL Lock Acquisition

During the lock acquisition period, only Register R0 (Address 0x4000) and Register R1 (Address 0x4002) are accessible through the control port. Because all other registers require a valid main

STARTUP, INITIALIZATION, AND POWER

clock for reading and writing, do not attempt to access any other register. Any read or write is prohibited until the core clock enable bit (COREN) and the lock bit are both asserted.

To program the PLL during initialization or reconfiguration of the clock setting, the following procedure must be followed:

1. Power down the PLL.
2. Reset the PLL control register.

3. Start the PLL.
4. Poll the lock bit.
5. Assert the core clock enable bit after the PLL lock is acquired.

The PLL control register (Register R1, Address 0x4002) is a 48-bit register where all bits must be written with a single continuous write to the control port.

CLOCKING AND SAMPLING RATES

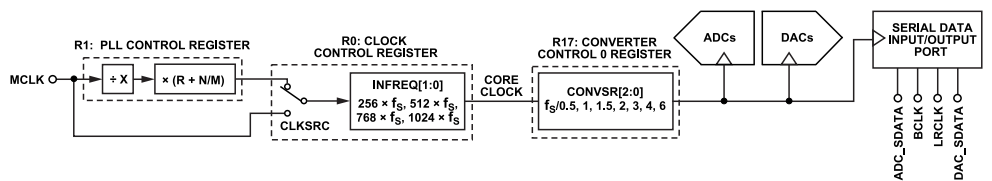

Figure 29. Clock Tree Diagram

CORE CLOCK

Clocks for the converters and the serial ports are derived from the core clock. The core clock can be derived directly from MCLK or it can be generated by the PLL. The CLKSRC bit (Bit 3 in Register R0, Address 0x4000) determines the clock source.

The INFREQ[1:0] bits should be set according to the expected input clock rate selected by CLKSRC; this value also determines the core clock rate and the base sampling frequency, f_s .

For example, if the input to CLKSRC = 49.152 MHz (from PLL), then

$$INFREQ[1:0] = 1024 \times f_s$$

$$f_s = 49.152 \text{ MHz} / 1024 = 48 \text{ kHz}$$

The PLL output clock rate is always $1024 \times f_s$, and the clock control register automatically sets the INFREQ[1:0] bits to $1024 \times f_s$ when using the PLL. When using a direct clock, the INFREQ[1:0] frequency should be set according to the MCLK pin clock rate and the desired base sampling frequency.

Table 11. Clock Control Register (Register R0, Address 0x4000)

Bits	Bit Name	Settings
3	CLKSRC	0: Direct from MCLK pin (default) 1: PLL clock
[2:1]	INFREQ[1:0]	00: $256 \times f_s$ (default) 01: $512 \times f_s$ 10: $768 \times f_s$ 11: $1024 \times f_s$
0	COREN	0: Core clock disabled (default) 1: Core clock enabled

SAMPLING RATES

The ADCs, DACs, and serial port share a common sampling rate that is set in Register R17 (Converter Control 0 register, Address 0x4017). The CONVSR[2:0] bits set the sampling rate as a ratio of the base sampling frequency.

Table 12 and Table 13 list the sampling rate divisions for common base sampling rates.

Table 12. 48 kHz Base Sampling Rate Divisions

Base Sampling Frequency	Sampling Rate Scaling	Sampling Rate
$f_s = 48 \text{ kHz}$	$f_s/1$	48 kHz
	$f_s/6$	8 kHz
	$f_s/4$	12 kHz
	$f_s/3$	16 kHz
	$f_s/2$	24 kHz
	$f_s/1.5$	32 kHz
	$f_s/0.5$	96 kHz

Table 13. 44.1 kHz Base Sampling Rate Divisions

Base Sampling Frequency	Sampling Rate Scaling	Sampling Rate
$f_s = 44.1 \text{ kHz}$	$f_s/1$	44.1 kHz
	$f_s/6$	7.35 kHz
	$f_s/4$	11.025 kHz
	$f_s/3$	14.7 kHz
	$f_s/2$	22.05 kHz
	$f_s/1.5$	29.4 kHz
	$f_s/0.5$	88.2 kHz

CLOCKING AND SAMPLING RATES

PLL

The PLL uses the MCLK as a reference to generate the core clock. PLL settings are set in Register R1 (PLL control register, Address 0x4002). Depending on the MCLK frequency, the PLL must be set for either integer or fractional mode. The PLL can accept input frequencies in the range of 8 MHz to 27 MHz.

All six bytes in the PLL control register must be written with a single continuous write to the control port.

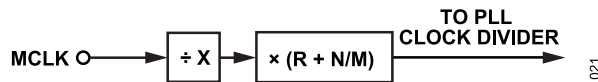

Figure 30. PLL Block Diagram

Integer Mode

Integer mode is used when the MCLK is an integer (R) multiple of the PLL output ($1024 \times f_S$).

For example, if MCLK = 12.288 MHz and $f_S = 48$ kHz, then

Table 14. PLL Control Register (Register R1, Address 0x4002)

Bits	Bit Name	Description
[47:32]	M[15:0]	Denominator of the fractional PLL: 16-bit binary number 0x00FD: M = 253 (default)
[31:16]	N[15:0]	Numerator of the fractional PLL: 16-bit binary number 0x000C: N = 12 (default)
[14:11]	R[3:0]	Integer part of PLL: four bits, only values 2 to 8 are valid 0010: R = 2 (default) 0011: R = 3 0100: R = 4 0101: R = 5 0110: R = 6 0111: R = 7 1000: R = 8
[10:9]	X[1:0]	PLL input clock divider 00: X = 1 (default) 01: X = 2 10: X = 3 11: X = 4
8	Type	PLL operation mode 0: Integer (default) 1: Fractional
1	Lock	PLL lock (read-only bit) 0: PLL unlocked (default) 1: PLL locked
0	PLLEN	PLL enable 0: PLL disabled (default) 1: PLL enabled

$$\text{PLL required output} = 1024 \times 48 \text{ kHz} = 49.152 \text{ MHz}$$

$$R = 49.152 \text{ MHz} / 12.288 \text{ MHz} = 4$$

In integer mode, the values set for N and M are ignored.

Fractional Mode

Fractional mode is used when the MCLK is a fractional ($R + (N/M)$) multiple of the PLL output.

For example, if MCLK = 12 MHz and $f_S = 48$ kHz, then

$$\text{PLL required output} = 1024 \times 48 \text{ kHz} = 49.152 \text{ MHz}$$

$$R + (N/M) = 49.152 \text{ MHz} / 12 \text{ MHz} = 4 + (12/125)$$

Common fractional PLL parameter settings for 44.1 kHz and 48 kHz sampling rates can be found in Table 15 and Table 16.

The PLL outputs a clock in the range of 41 MHz to 54 MHz, which should be taken into account when calculating PLL values and MCLK frequencies.

CLOCKING AND SAMPLING RATES

Table 15. Fractional PLL Parameter Settings for $f_S = 44.1 \text{ kHz}$ (PLL Output = $45.1584 \text{ MHz} = 1024 \times f_S$)

MCLK Input (MHz)	Input Divider (X)	Integer (R)	Denominator (M)	Numerator (N)	R2: PLL Control Setting (Hex)
8	1	5	625	403	0x0271 0193 2901
12	1	3	625	477	0x0271 01DD 1901
13	1	3	8125	3849	0x1FBD 0F09 1901
14.4	2	6	125	34	0x007D 0022 3301
19.2	2	4	125	88	0x007D 0058 2301
19.68	2	4	1025	604	0x0401 025C 2301
19.8	2	4	1375	772	0x055F 0304 2301
24	2	3	625	477	0x0271 01DD 1B01
26	2	3	8125	3849	0x1FBD 0F09 1B01
27	2	3	1875	647	0x0753 0287 1B01

Table 16. Fractional PLL Parameter Settings for $f_S = 48 \text{ kHz}$ (PLL Output = $49.152 \text{ MHz} = 1024 \times f_S$)

MCLK Input (MHz)	Input Divider (X)	Integer (R)	Denominator (M)	Numerator (N)	R2: PLL Control Setting (Hex)
8	1	6	125	18	0x007D 0012 3101
12	1	4	125	12	0x007D 000C 2101
13	1	3	1625	1269	0x0659 04F5 1901
14.4	2	6	75	62	0x004B 003E 3301
19.2	2	5	25	3	0x0019 0003 2B01
19.68	2	4	205	204	0x00CD 00CC 2301
19.8	2	4	825	796	0x0339 031C 2301
24	2	4	125	12	0x007D 000C 2301
26	2	3	1625	1269	0x0659 04F5 1B01
27	2	3	1125	721	0x0465 02D1 1B01

Table 17. Integer PLL Parameter Settings for $f_S = 48 \text{ kHz}$ (PLL Output = $49.152 \text{ MHz} = 1024 \times f_S$)

MCLK Input (MHz)	Input Divider (X)	Integer (R)	Denominator (M)	Numerator (N)	R2: PLL Control Setting (Hex) ¹
12.288	1	4	Don't care	Don't care	0XXXXX XXXX 2001
24.576	1	2	Don't care	Don't care	0XXXXX XXXX 1001

¹ X = don't care.

RECORD SIGNAL PATH

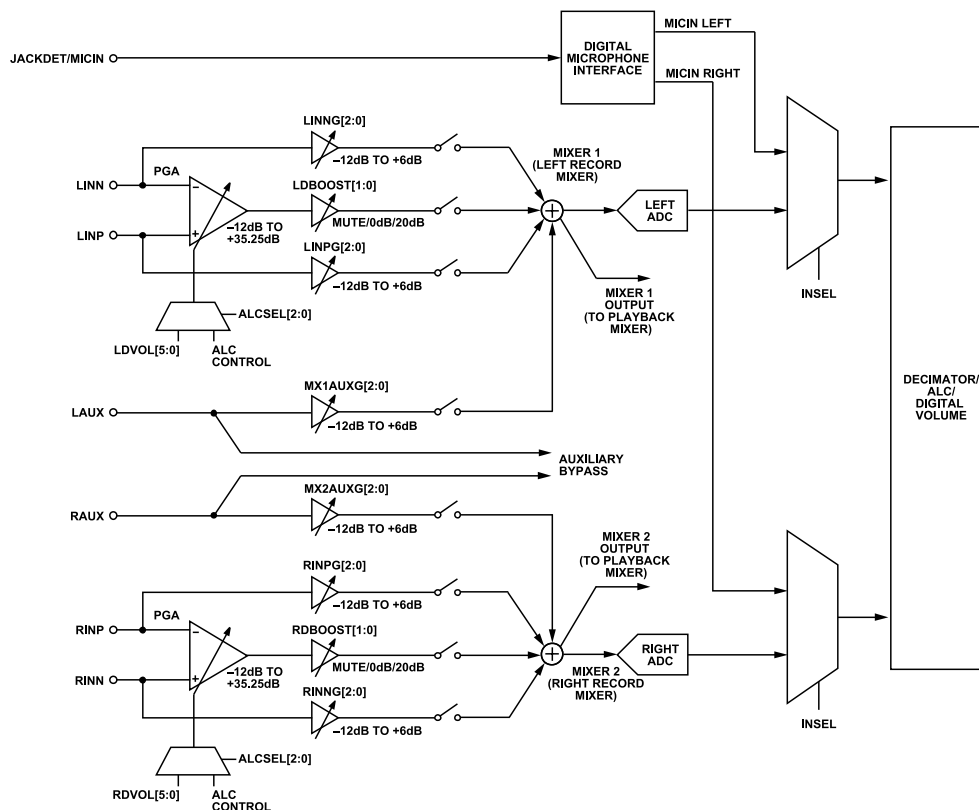

Figure 31. Record Signal Path

INPUT SIGNAL PATHS

The ADAU1961 can accept both line level and microphone inputs. The analog inputs can be configured in a single-ended or differential configuration. There is also an input for a digital microphone. The analog inputs are biased at $AVDD/2$. Unused input pins should be connected to CM.

Each of the six analog inputs has individual gain controls (boost or cut). The input signals are mixed and routed to an ADC. The mixed input signals can also bypass the ADCs and be routed directly to the playback mixers. Left channel inputs are mixed before the left ADC; however, it is possible to route the mixed analog signal around the ADC and output it into a left or right output channel. The same capabilities apply to the right channel and the right ADC.

Signals are inverted through the PGAs and the mixers. The result of this inversion is that differential signals input through the PGA are output from the ADCs at the same polarity as they are input. Single-ended inputs that pass through the mixer but not through the PGA are inverted. The ADCs are noninverting.

The input impedance of the analog inputs varies with the gain of the PGA. This impedance ranges from 1.7 k Ω at the 35.25 dB gain setting to 80.4 k Ω at the -12 dB setting. This range is shown in Figure 22.

Analog Microphone Inputs

For microphone inputs, configure the part in either stereo pseudo-differential mode or stereo full differential mode.

The LINN and LIMP pins are the inverting and noninverting inputs for the left channel, respectively. The RINN and RINP pins are the inverting and noninverting inputs for the right channel, respectively.

For a differential microphone input, connect the positive signal to the noninverting input of the PGA and the negative signal to the inverting input of the PGA, as shown in Figure 32. The PGA settings are controlled with Register R8 (left differential input volume control register, Address 0x400E) and Register R9 (right differential input volume control register, Address 0x400F). The PGA must first be enabled by setting the RDEN and LDEN bits.

RECORD SIGNAL PATH

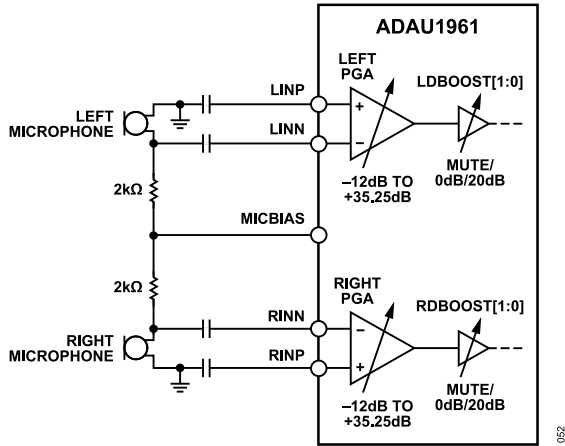

Figure 32. Stereo Differential Microphone Configuration

The PGA can also be used for single-ended microphone inputs. Connect LINP and/or RINP to the CM pin. In this configuration, the signal connects to the inverting input of the PGA, LINN and/or RINN, as shown in Figure 33.

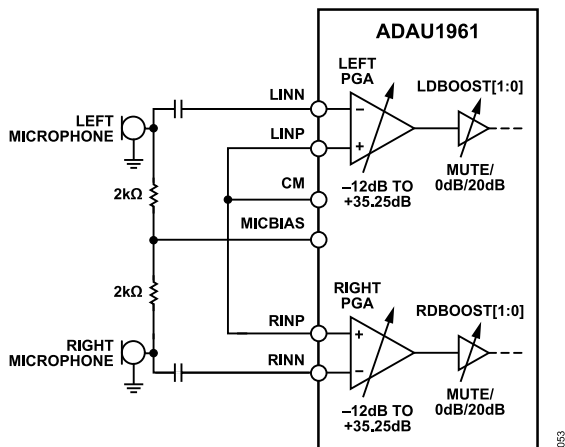

Figure 33. Stereo Single-Ended Microphone Configuration

Analog Line Inputs

Line input signals can be accepted by any analog input. It is possible to route signals on the RINN, RINP, LINN, and LINP pins around the differential amplifier to their own amplifier and to use these pins as single-ended line inputs by disabling the LDEN and RDEN bits (Bit 0 in Register R8, Address 0x400E, and Bit 0 in Register R9, Address 0x400F). Figure 34 depicts a stereo single-ended line input using the RINN and LINN pins.

The LAUX and RAUX pins are single-ended line inputs. They can be used together as a stereo single-ended auxiliary input, as shown in Figure 34. These inputs can bypass the input gain control, mixers, and ADCs to directly connect to the output playback mixers (see auxiliary bypass in Figure 31).

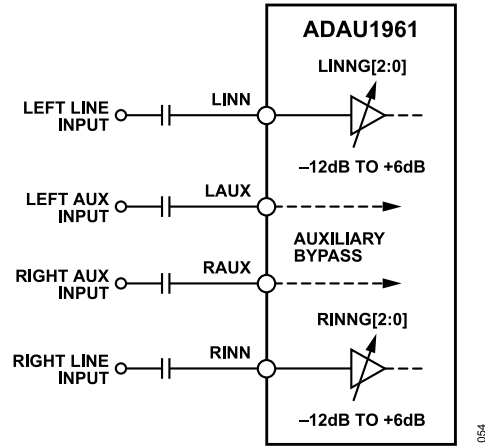

Figure 34. Stereo Single-Ended Line Input with Stereo Auxiliary Bypass

Digital Microphone Input

When using a digital microphone connected to the JACKDET/MICIN pin, the JDFUNC[1:0] bits in Register R2 (Address 0x4008) must be set to 10 to enable the microphone input and disable the jack detection function. The ADAU1961 must operate in main mode and source BCLK to the input clock of the digital microphone.

The digital microphone signal bypasses record path mixers and ADCs and is routed directly into the decimation filters. The digital microphone and ADCs share decimation filters and, therefore, both cannot be used simultaneously. The digital microphone input select bit, INSEL, can be set in Register R19 (ADC control register, Address 0x4019). Figure 35 depicts the digital microphone interface and signal routing.

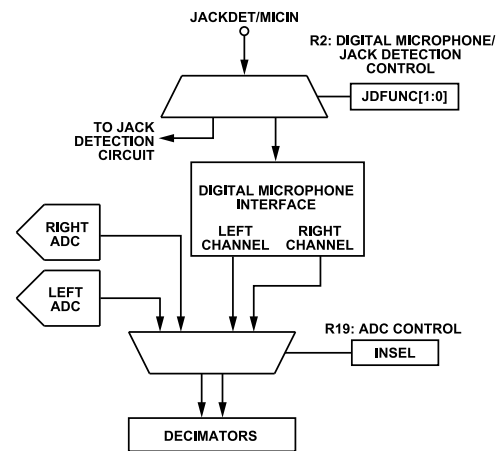

Figure 35. Digital Microphone Interface Block Diagram

Microphone Bias

The MICBIAS pin provides a voltage reference for electret analog microphones. The MICBIAS voltage is set in Register R10 (record microphone bias control register, Address 0x4010). In this register, the MICBIAS output can be enabled or disabled. Additional options include high performance operation and a gain boost. The gain

RECORD SIGNAL PATH

boost provides two different voltage biases: $0.65 \times AVDD$ or $0.90 \times AVDD$. When enabled, the high performance bit increases supply current to the microphone bias circuit to decrease rms input noise.

The MICBIAS pin can also be used to cleanly supply voltage to digital microphones or analog microphones with separate power supply pins.

ANALOG-TO-DIGITAL CONVERTERS

The ADAU1961 uses two 24-bit Σ - Δ analog-to-digital converters (ADCs) with selectable oversampling ratios of $64\times$ or $128\times$ (selected by Bit 3 in Register R17, Address 0x4017).

ADC Full-Scale Level

The full-scale input to the ADCs (0 dBFS) is 1.0 V rms with $AVDD = 3.3$ V. This full-scale analog input will output a digital signal at -1.38 dBFS. This gain offset is built into the ADAU1961 to prevent clipping. The full-scale input level scales linearly with the level of $AVDD$.

For single-ended and pseudo-differential signals, the full-scale value corresponds to the signal level at the pins, 0 dBFS.

The full differential full-scale input level is measured after the differential amplifier, which corresponds to -6 dBFS at each pin.

Signal levels above the full-scale value cause the ADCs to clip.

Digital ADC Volume Control

The digital ADC volume can be attenuated using Register R20 (left input digital volume register, Address 0x401A) and Register R21 (right input digital volume register, Address 0x401B).

High-Pass Filter

By default, a high-pass filter is used in the ADC path to remove dc offsets; this filter can be enabled or disabled in Register R19 (ADC control register, Address 0x4019). At $f_s = 48$ kHz, the corner frequency of this high-pass filter is 2 Hz.

AUTOMATIC LEVEL CONTROL (ALC)

The ADAU1961 contains a hardware automatic level control (ALC). The ALC is designed to continuously adjust the PGA gain to keep the recording volume constant as the input level varies.

For optimal noise performance, the ALC uses the analog PGA to adjust the gain instead of using a digital method. This ensures that the ADC noise is not amplified at low signal levels. Extremely small gain step sizes are used to ensure high audio quality during gain changes.

To use the ALC function, the inputs must be applied either differentially or pseudo-differentially to input pins LINN and LINP, for the left channel, and RINN and RINP, for the right channel. The ALC function is not available for the auxiliary line input pins, LAUX and RAUX.

A block diagram of the ALC block is shown in [Figure 36](#). The ALC logic receives the ADC output signals and analyzes these digital signals to set the PGA gain. The ALC control registers are used to control the time constants and output levels, as described in this section.

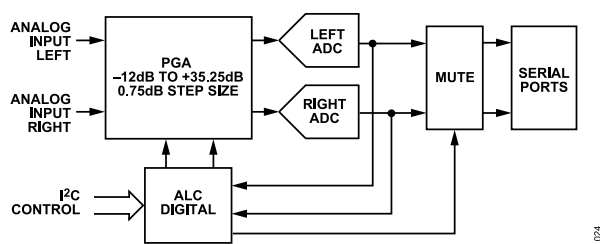

Figure 36. ALC Architecture

ALC PARAMETERS

The ALC function is controlled with the ALC control registers (Address 0x4011 through Address 0x4014) using the following parameters:

- ▶ **ALCSEL[2:0]:** The ALC select bits are used to enable the ALC and set the mode to left only, right only, or stereo. In stereo mode, the greater of the left or right inputs is used to calculate the gain, and the same gain is then applied to both the left and right channels.
- ▶ **ALCTARG[3:0]:** The ALC target is the desired input recording level that the ALC attempts to achieve.
- ▶ **ALCATCK[3:0]:** The ALC attack time sets how fast the ALC starts attenuating after a sudden increase in input level above the ALC target. Although it may seem that the attack time should be set as fast as possible to avoid clipping on transients, using a moderate value results in better overall sound quality. If the value is too fast, the ALC overreacts to very short transients, causing audible gain-pumping effects, which sounds worse than using a moderate value that allows brief periods of clipping on transients. A typical setting for music recording is 384 ms. A typical setting for voice recording is 24 ms.
- ▶ **ALCHOLD[3:0]:** These bits set the ALC hold time. When the output signal falls below the target output level, the gain is not

increased unless the output remains below the target level for the period of time set by the hold time bits. The hold time is used to prevent the gain from modulating on a steady low frequency sine wave signal, which would cause distortion.

- ▶ **ALCDEC[3:0]:** The ALC decay time sets how fast the ALC increases the PGA gain after a sudden decrease in input level below the ALC target. A very slow setting can be used if the main function of the ALC is to set a music recording level. A faster setting can be used if the function of the ALC is to compress the dynamic range of a voice recording. Using a very fast decay time can cause audible artifacts such as noise pumping or distortion. A typical setting for music recording is 24.58 sec. A typical setting for voice recording is 1.54 sec.
- ▶ **ALCMAX[2:0]:** The maximum ALC gain bits are used to limit the maximum gain that can be programmed into the ALC. This can be used to prevent excessive noise in the recording for small input signals. Note that setting this register to a low value may prevent the ALC from reaching its target output level, but this behavior is often desirable to achieve the best overall sound.

[Figure 37](#) shows the dynamic behavior of the PGA gain for a tone-burst input. The target output is achieved for three different input levels, with the effect of attack, hold, and decay shown in the figure. Note that for very small signals, the maximum PGA gain may prevent the ALC from achieving its target level; in the same way, for very large inputs, the minimum PGA gain may prevent the ALC from achieving its target level (assuming that the target output level is set to a very low value). The effects of the PGA gain limit are shown in the input/output graph of [Figure 38](#).

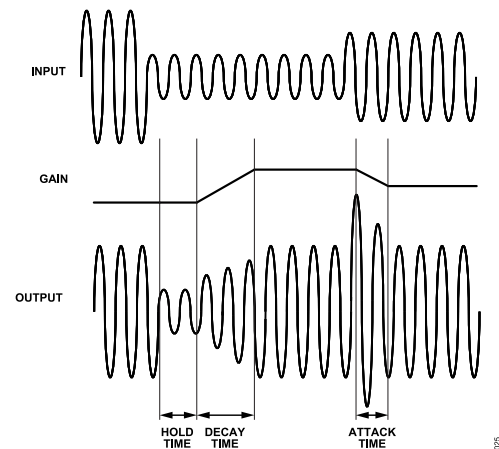

Figure 37. Basic ALC Operation

AUTOMATIC LEVEL CONTROL (ALC)

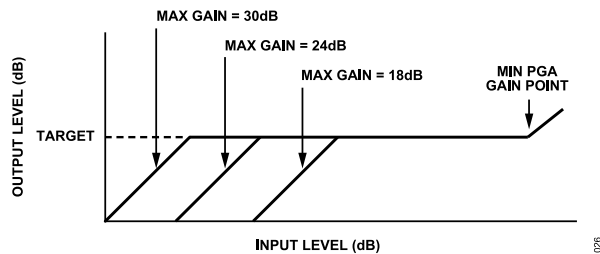

Figure 38. Effect of Varying the Maximum Gain Parameter

NOISE GATE FUNCTION

When using the ALC, one potential problem is that for small input signals, the PGA gain can become very large. A side effect of this is that the noise is amplified along with the signal of interest. To avoid this situation, the ADAU1961 noise gate can be used. The noise gate cuts off the ADC output when its signal level is below a set threshold. The noise gate is controlled using the following parameters in the ALC Control 3 register (Address 0x4014):

- ▶ NGTYP[1:0]: The noise gate type is set to one of four modes by writing to the NGTYP[1:0] bits.
- ▶ NGEN: The noise gate function is enabled by writing to the NGEN bit.
- ▶ NGTHR[4:0]: The threshold for muting the output is set by writing to the NGTHR[4:0] bits.

One common problem with noise gate functions is chatter, where a small signal that is close to the noise gate threshold varies in amplitude, causing the noise gate function to open and close rapidly. This causes an unpleasant sound.

To reduce this effect, the noise gate in the ADAU1961 uses a combination of a timeout period and hysteresis. The timeout period is set to 250 ms, so the signal must consistently be below the threshold for 250 ms before the noise gate operates. Hysteresis is used so that the threshold for coming out of the mute state is 6 dB higher than the threshold for going into the mute state. There are four operating modes for the noise gate.

Noise Gate Mode 0 (see Figure 39) is selected by setting the NGTYP[1:0] bits to 00. In this mode, the current state of the PGA gain is held at its current state when the noise gate logic is activated. This prevents a large increase in background noise during periods of silence. When using this mode, it is advisable to use a relatively slow decay time. This is because the noise gate takes at least 250 ms to activate, and if the PGA gain has already increased to a large value during this time, the value at which the gain is held will be large.

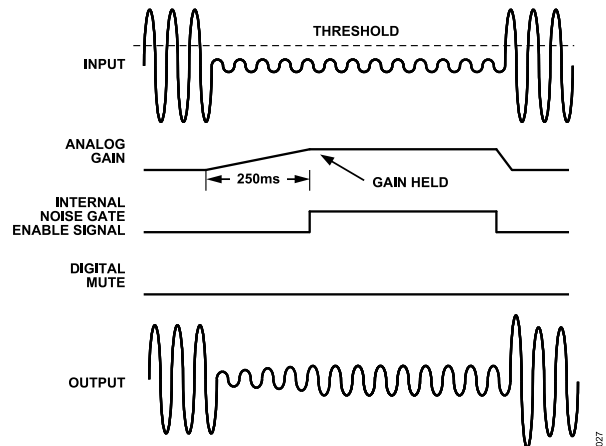

Figure 39. Noise Gate Mode 0 (PGA Gain Hold)

Noise Gate Mode 1 (see Figure 40) is selected by setting the NGTYP[1:0] bits to 01. In this mode, the ADAU1961 does a simple digital mute of the ADC output. Although this mode completely eliminates any background noise, the effect of an abrupt mute may not be pleasant to the ear.

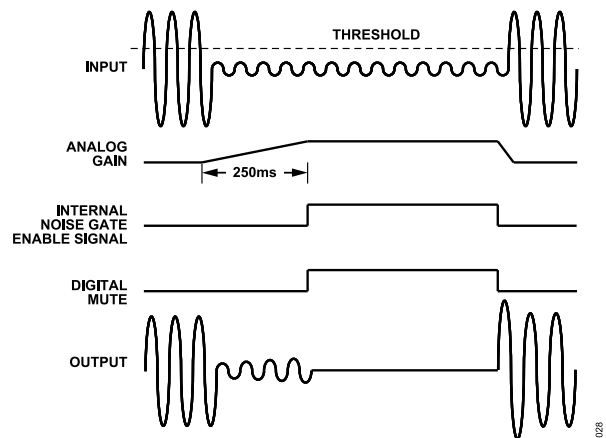

Figure 40. Noise Gate Mode 1 (Digital Mute)

Noise Gate Mode 2 (see Figure 41) is selected by setting the NGTYP[1:0] bits to 10. In this mode, the ADAU1961 improves the sound of the noise gate operation by first fading the PGA gain over a period of about 100 ms to the minimum PGA gain value. The ADAU1961 does not do a hard mute after the fade is complete, so some small background noise will still exist.

AUTOMATIC LEVEL CONTROL (ALC)

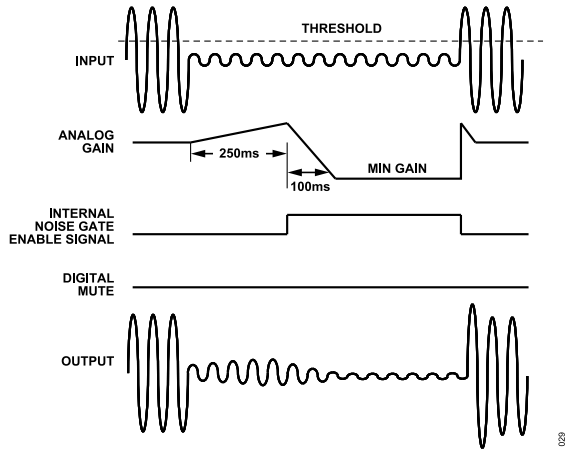

Figure 41. Noise Gate Mode 2 (Analog Fade)

Noise Gate Mode 3 (see [Figure 42](#)) is selected by setting the NGTYP[1:0] bits to 11. This mode is the same as Mode 2 except that at the end of the PGA fade gain interval, a digital mute is performed. In general, this mode is the best-sounding mode,

because the audible effect of the digital hard mute is reduced by the fact that the gain has already faded to a low level before the mute occurs.

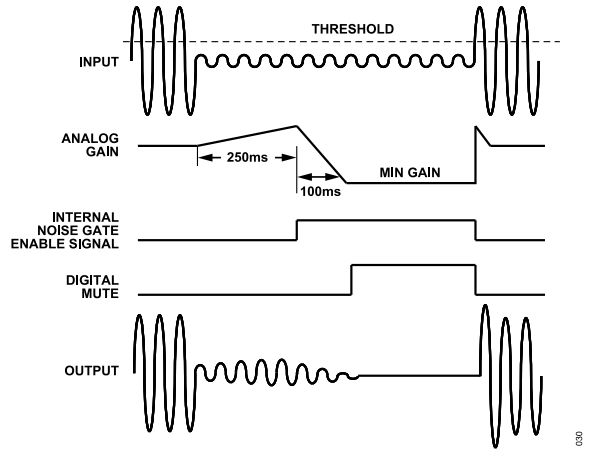

Figure 42. Noise Gate Mode 3 (Analog Fade/Digital Mute)

PLAYBACK SIGNAL PATH

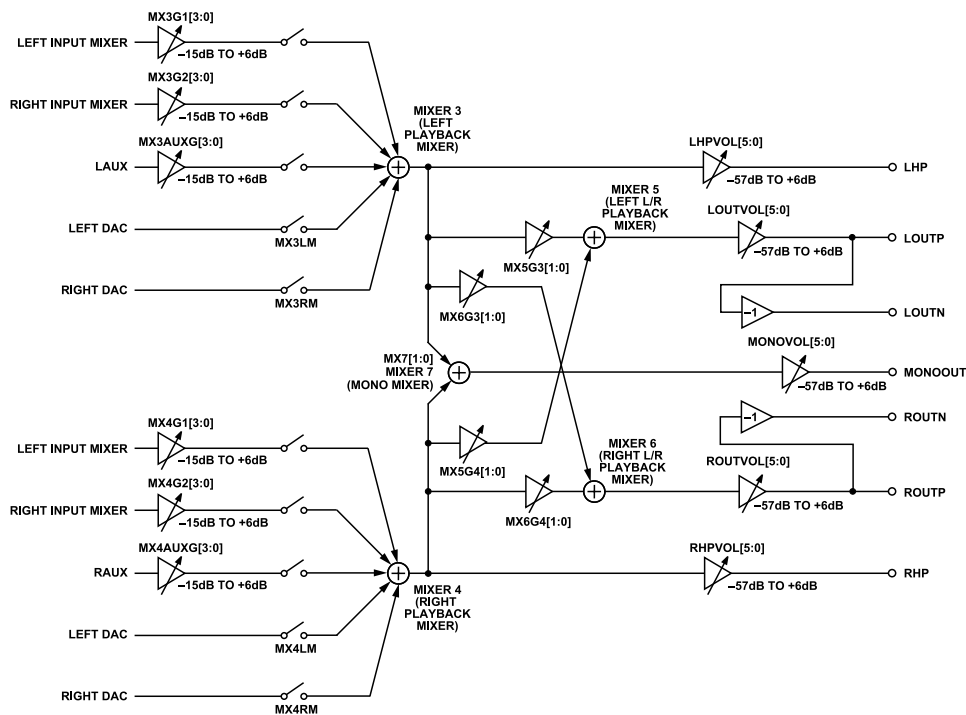

Figure 43. Playback Signal Path

OUTPUT SIGNAL PATHS

The outputs of the ADAU1961 can be configured as a variety of differential or single-ended outputs. All analog output pins are capable of driving headphone or earpiece speakers. There are selectable output paths for stereo signals or a downmixed mono output. The line outputs can drive a load of at least 10 k Ω or can be put into HP mode to drive headphones or earpiece speakers. The analog output pins are biased at $AVDD/2$.

With a 0 dBFS digital input and $AVDD = 3.3$ V, the full-scale output level is 920 mV rms.

Signals are inverted through the mixers and volume controls. The result of this inversion is that the polarity of the differential outputs and the headphone outputs is preserved. The single-ended mono output is inverted. The DACs are noninverting.

Routing Flexibility

The playback path contains five mixers (Mixer 3 to Mixer 7) that perform the following functions:

- ▶ Mix signals from the record path and the DACs.
- ▶ Mix or swap the left and right channels.
- ▶ Mix a mono signal or generate a common-mode output.

Mixer 3 and Mixer 4 are dedicated to mixing signals from the record path and the DACs. Each of these two mixers can accept signals from the left and right DACs, the left and right input mixers, and the dedicated channel auxiliary input. Signals coming from the record path can be boosted or cut before the playback mixer.

For example, the MX4G2[3:0] bits set the gain from the output of Mixer 2 (right record channel) to the input of Mixer 4, hence the naming convention.

Signals coming from the DACs have digital volume attenuation controls set in Register R20 (left input digital volume register, Address 0x401A) and Register R21 (right input digital volume register, Address 0x401B).

HEADPHONE OUTPUT

The LHP and RHP pins can be driven by either a line output driver or a headphone driver by setting the HPMODE bit in Register R30 (playback headphone right volume control register, Address 0x4024). The headphone outputs can drive a load of at least 16 Ω .

Separate volume controls for the left and right channels range from -57 dB to +6 dB. Slew can be applied to all the playback volume controls using the ASLEW[1:0] bits in Register R34 (playback pop/click suppression register, Address 0x4028).

Capless Headphone Configuration

The headphone outputs can be configured in a capless output configuration with the MONOOUT pin used as a dc virtual ground reference. Figure 44 depicts a typical playback path in a capless headphone configuration. Table 18 lists the register settings for this configuration. As shown in this table, the MONOOUT pin outputs common mode ($AVDD/2$), which is used as the virtual headphone reference.

PLAYBACK SIGNAL PATH

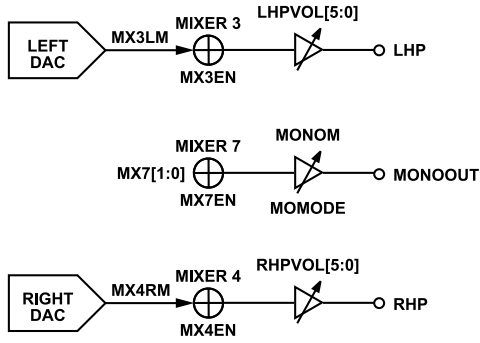

Figure 44. Capless Headphone Configuration Diagram

Table 18. Capless Headphone Register Settings

Register	Bit Name	Setting
R36	DACEN[1:0]	11 = both DACs on
R22	MX3EN	1 = enable Mixer 3
	MX3LM	1 = unmute left DAC input
R24	MX4EN	1 = enable Mixer 4
	MX4RM	1 = unmute right DAC input
R28	MX7EN	1 = enable Mixer 7
	MX7[1:0]	00 = common-mode output
R33	MONOM	1 = unmute mono output
	MOMODE	1 = headphone output
R29	LHPVOL[5:0]	Desired volume for LHP output
	LHPM	1 = unmute left headphone output
R30	HPMODE	1 = headphone output
	RHPVOL[5:0]	Desired volume for RHP output
	RHPM	1 = unmute right headphone output

Headphone Output Power-Up/Power-Down Sequencing

To prevent pops when turning on the headphone outputs, the user must wait at least 4 ms to unmute these outputs after enabling the headphone output with the HPMODE bit. This is because of an internal capacitor that must charge before these outputs can be used. Figure 45 and Figure 46 illustrate the headphone power-up/power-down sequencing.

For capless headphones, configure the MONOOUT pin before unmuting the headphone outputs.

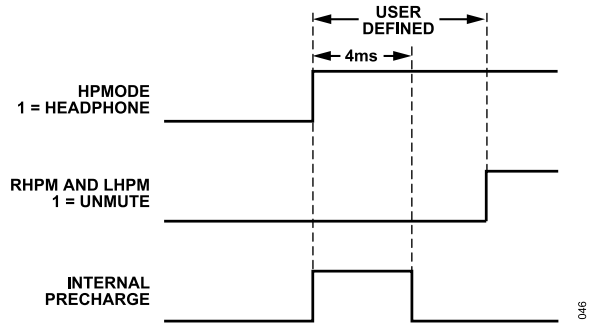

Figure 45. Headphone Output Power-Up Timing

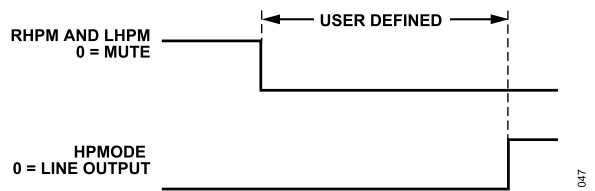

Figure 46. Headphone Output Power-Down Timing

Ground-Centered Headphone Configuration

The headphone outputs can also be configured as ground-centered outputs by placing coupling capacitors on the LHP and RHP pins. Ground-centered headphones should use the AGND pin as the ground reference.

When the headphone outputs are configured in this manner, the capacitors create a high-pass filter on the outputs. The corner frequency of this filter, at which point its attenuation is 3 dB, is calculated by the following formula:

$$f_{3dB} = 1/(2\pi \times R \times C) \tag{1}$$

where:

C is the capacitor value.

R is the impedance of the headphones.

For a typical headphone impedance of 16 Ω and a 47 μF capacitor, the corner frequency is 211 Hz.

Jack Detection

When the JACKDET/MICIN pin is set to the jack detect function, a flag on this pin can be used to mute the line outputs when headphones are plugged into the jack. This pin can be configured in Register R2 (digital microphone/jack detection control register, Address 0x4008). The JDFUNC[1:0] bits set the functionality of the JACKDET/MICIN pin.

Additional settings for jack detection include debounce time (JDDB[1:0] bits) and detection polarity (JDPOL bit). Because the jack detection and digital microphone share a pin, both functions cannot be used simultaneously.

PLAYBACK SIGNAL PATH

POP-AND-CLICK SUPPRESSION

Upon power-up, precharge circuitry is enabled to suppress pops and clicks. After power-up, the precharge circuitry can be put into a low power mode using the POPMODE bit in Register R34 (playback pop/click suppression register, Address 0x4028).

The precharge time depends on the capacitor value on the CM pin and the RC time constant of the load. For a typical line output load, the precharge time is between 2 ms and 3 ms. After this precharge time, the POPMODE bit can be set to low power mode.

Changing any register settings that affect the signal path can cause pops and clicks on the analog outputs. To avoid these pops and clicks, mute the appropriate outputs using Register R29 to Register R32 (Address 0x4023 to Address 0x4026). Unmute the analog outputs after the changes are made.

LINE OUTPUTS

The line output pins (LOUTP, LOUTN, ROUTP, and ROUTN) can be used to drive both differential and single-ended loads. In their default settings, these pins can drive typical line loads of 10 k Ω or greater, but they can also be put into headphone mode by setting the LOMODE bit in Register R31 (playback line output left volume control register, Address 0x4025) and the ROMODE bit in Register R32 (playback line output right volume control register, Address 0x4026). In headphone mode, the line output pins are capable of driving headphone and earpiece speakers of 16 Ω or greater. The output impedance of the line outputs is approximately 1 k Ω .

When the line output pins are used in single-ended mode, LOUTP and ROUTP should be used to output the signals, and LOUTN and ROUTN should be left unconnected.

The volume controls for these outputs range from -57 dB to +6 dB. Slew can be applied to all the playback volume controls using the ASLEW[1:0] bits in Register R34 (playback pop/click suppression register, Address 0x4028).

The MX5G4[1:0], MX5G3[1:0], MX6G3[1:0], and MX6G4[1:0] bits can all provide a 6 dB gain boost to the line outputs. This gain boost allows single-ended output signals to achieve 0 dBV (1.0 V rms) and differential output signals to achieve up to 6 dBV (2.0 V rms). For more information, see Register R26 (playback L/R mixer left (Mixer 5) line output control register, Address 0x4020) and Register R27 (playback L/R mixer right (Mixer 6) line output control register, Address 0x4021).

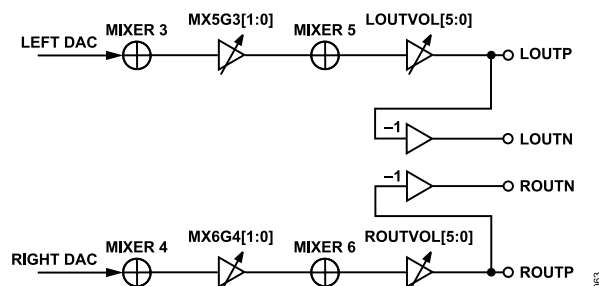

Figure 47. Differential Line Output Configuration

CONTROL PORTS

The ADAU1961 can operate in one of two control modes:

- ▶ I²C control
- ▶ SPI control

The ADAU1961 has both a 4-wire SPI control port and a 2-wire I²C bus control port. Both ports can be used to set the registers. The part defaults to I²C mode, but it can be put into SPI control mode by pulling the CLATCH pin low three times.

The control port is capable of full read/write operation for all addressable registers. The ADAU1961 must have a valid main clock in order to write to all registers except for Register R0 (Address 0x4000) and Register R1 (Address 0x4002).

All addresses can be accessed in both a single-address mode or a burst mode. The first byte (Byte 0) of a control port write contains the 7-bit chip address plus the R/W bit. The next two bytes (Byte 1 and Byte 2) together form the subaddress of the register location within the ADAU1961. This subaddress must be two bytes long because the memory locations within the ADAU1961 are directly addressable and their sizes exceed the range of single-byte addressing. All subsequent bytes (starting with Byte 3) contain the data. The number of bytes per word depends on the type of data that is being written.

The control port pins are multifunctional, depending on the mode in which the part is operating. Table 19 describes these multiple functions.

Table 19. Control Port Pin Functions

Pin Name	I ² C Mode	SPI Mode
SCL/CCLK	SCL: input clock	CCLK: input clock
SDA/COUT	SDA: open-collector input/output	COUT: output
ADDR1/CDATA	I ² C Address Bit 1: input	CDATA: input
ADDR0/CLATCH	I ² C Address Bit 0: input	CLATCH: input

BURST MODE WRITING AND READING

Burst mode addressing, where the subaddresses are automatically incremented at word boundaries, can be used for writing large amounts of data to contiguous registers. This increment happens automatically after a single-word write or read unless a stop condition is encountered (I²C) or CLATCH is brought high (SPI). A burst write starts like a single-word write, but following the first data-word, the data-word for the next immediate address can be written immediately without sending its two-byte address.

The registers in the ADAU1961 are one byte wide with the exception of the PLL control register, which is six bytes wide. The autoincrement feature knows the word length at each subaddress, so the subaddress does not need to be specified manually for each address in a burst write.

The subaddresses are autoincremented by 1 following each read or write of a data-word, regardless of whether there is a valid register word at that address. Address holes in the register map can be

written to or read from without consequence. In the ADAU1961, these address holes exist at Address 0x4001, Address 0x4003 to Address 0x4007, Address 0x402E, and Address 0x4032 to Address 0x4035. A single-byte write to these registers is ignored by the ADAU1961, and a read returns a single byte 0x00.

I²C PORT

The ADAU1961 supports a 2-wire serial (I²C-compatible) micro-processor bus driving multiple peripherals. Two pins, serial data (SDA) and serial clock (SCL), carry information between the ADAU1961 and the system I²C main controller. In I²C mode, the ADAU1961 is always a subordinate on the bus, meaning that it cannot initiate a data transfer. Each subordinate device is recognized by a unique address. The address and R/W byte format is shown in Table 20. The address resides in the first seven bits of the I²C write. Bits[5:6] of the I²C address for the ADAU1961 are set by the levels on the ADDR1 and ADDR0 pins. The LSB of the address—the R/W bit—specifies either a read or write operation. Logic Level 1 corresponds to a read operation, and Logic Level 0 corresponds to a write operation.

Table 20. ADAU1961 I²C Address and Read/Write Byte Format

Bit 0	Bit 1	Bit 2	Bit 3	Bit 4	Bit 5	Bit 6	Bit 7
0	1	1	1	0	ADDR1	ADDR0	R/W

The SDA and SCL pins should each have a 2 kΩ pull-up resistor on the line connected to it. The voltage on these signal lines should not be higher than IOVDD (3.3 V).

Addressing

Initially, each device on the I²C bus is in an idle state and monitors the SDA and SCL lines for a start condition and the proper address. The I²C main initiates a data transfer by establishing a start condition, defined by a high-to-low transition on SDA while SCL remains high. This indicates that an address/ data stream follows. All devices on the bus respond to the start condition and shift the next eight bits (the 7-bit address plus the R/W bit) MSB first. The device that recognizes the transmitted address responds by pulling the data line low during the ninth clock pulse. This ninth bit is known as an acknowledge bit. All other devices withdraw from the bus at this point and return to the idle condition.

The R/W bit determines the direction of the data. A Logic 0 on the LSB of the first byte means that the main will write information to the peripheral, whereas a Logic 1 means that the main will read information from the peripheral after writing the subaddress and repeating the start address. A data transfer takes place until a stop condition is encountered. A stop condition occurs when SDA transitions from low to high while SCL is held high. Figure 48 shows the timing of an I²C write, and Figure 49 shows an I²C read.

Stop and start conditions can be detected at any stage during the data transfer. If these conditions are asserted out of sequence with normal read and write operations, the ADAU1961 immediately jumps to the idle condition. During a given SCL high period, the

CONTROL PORTS

user should only issue one start condition, one stop condition, or a single stop condition followed by a single start condition. If an invalid subaddress is issued by the user, the ADAU1961 does not issue an acknowledge and returns to the idle condition.

If the user exceeds the highest subaddress while in autoincrement mode, one of two actions is taken. In read mode, the ADAU1961 outputs the highest subaddress register contents until the main

device issues a no acknowledge, indicating the end of a read. A no acknowledge condition is where the SDA line is not pulled low on the ninth clock pulse on SCL. If the highest subaddress location is reached while in write mode, the data for the invalid byte is not loaded into any subaddress register, a no acknowledge is issued by the ADAU1961, and the part returns to the idle condition.

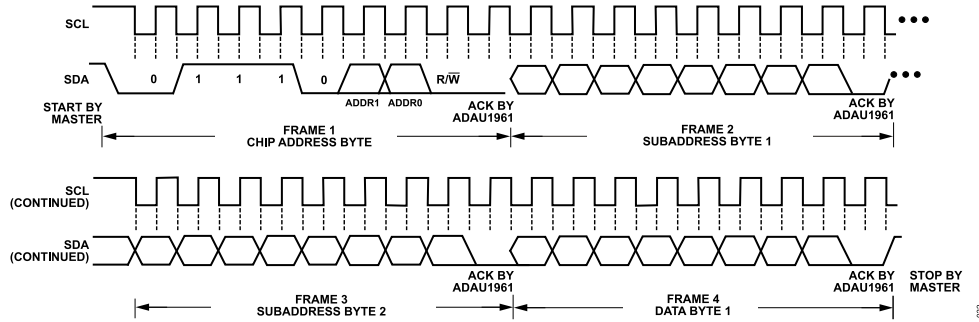

Figure 48. I²C Write to ADAU1961 Clocking

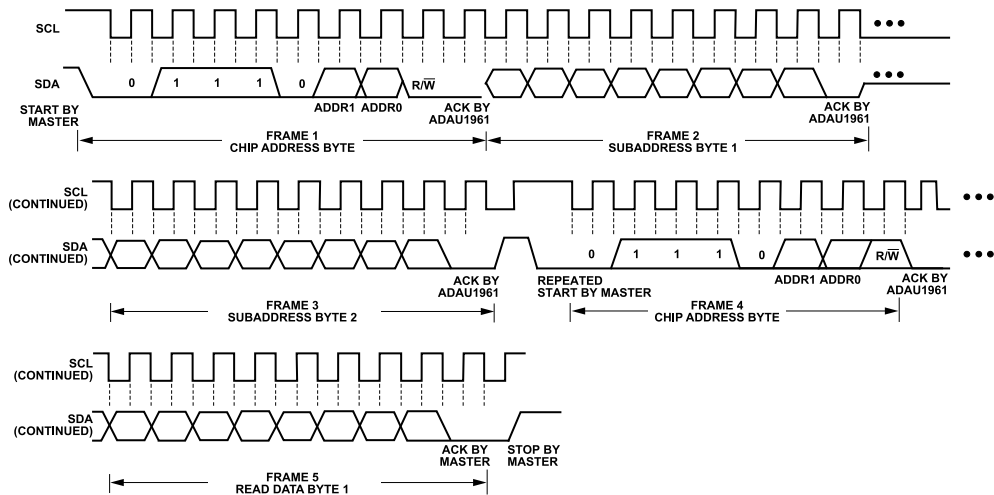

Figure 49. I²C Read from ADAU1961 Clocking

CONTROL PORTS

I²C Read and Write Operations

Figure 50 shows the format of a single-word write operation. Every ninth clock pulse, the ADAU1961 issues an acknowledge by pulling SDA low.

Figure 51 shows the format of a burst mode write sequence. This figure shows an example of a write to sequential single-byte registers. The ADAU1961 increments its subaddress register after every byte because the requested subaddress corresponds to a register or memory area with a 1-byte word length.

Figure 52 shows the format of a single-word read operation. Note that the first $\overline{R/\overline{W}}$ bit is 0, indicating a write operation. This is because the subaddress still needs to be written to set up the internal address. After the ADAU1961 acknowledges the receipt of the subaddress, the main must issue a repeated start command followed by the chip address byte with the $\overline{R/\overline{W}}$ bit set to 1 (read). This causes the ADAU1961 SDA to reverse and begin driving data back to the main. The main then responds every ninth pulse with an acknowledge pulse to the ADAU1961.

Figure 53 shows the format of a burst mode read sequence. This figure shows an example of a read from sequential single-byte registers. The ADAU1961 increments its subaddress register after every byte because the requested subaddress corresponds to a register or memory area with a 1-byte word length. The ADAU1961 always decodes the subaddress and sets the auto-increment circuit so that the address increments after the appropriate number of bytes.

Figure 50 to Figure 53 use the following abbreviations:

S = start bit

P = stop bit

AM = acknowledge by main

AS = acknowledge by subordinate

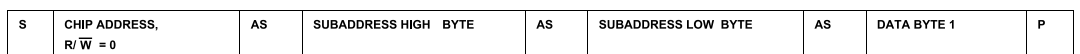

Figure 50. Single-Word I²C Write Format

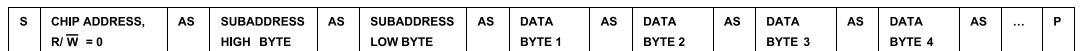

Figure 51. Burst Mode I²C Write Format



Figure 52. Single-Word I²C Read Format

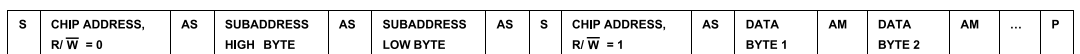

Figure 53. Burst Mode I²C Read Format

CONTROL PORTS

SPI PORT

By default, the ADAU1961 is in I²C mode, but it can be put into SPI control mode by pulling $\overline{\text{CLATCH}}$ low three times. This is done by performing three dummy writes to the SPI port (the ADAU1961 does not acknowledge these three writes). Beginning with the fourth SPI write, data can be written to or read from the IC. The ADAU1961 can be taken out of SPI mode only by a full reset initiated by power-cycling the IC.

The SPI port uses a 4-wire interface, consisting of the $\overline{\text{CLATCH}}$, CCLK, CDATA, and COUT signals, and it is always a subordinate port. The $\overline{\text{CLATCH}}$ signal should go low at the beginning of a transaction and high at the end of a transaction. The CCLK signal latches CDATA on a low-to-high transition. COUT data is shifted out of the ADAU1961 on the falling edge of CCLK and should be clocked into a receiving device, such as a microcontroller, on the CCLK rising edge. The CDATA signal carries the serial input data, and the COUT signal carries the serial output data. The COUT signal remains three-state until a read operation is requested. This allows other SPI-compatible peripherals to share the same readback line. All SPI transactions have the same basic format shown in Table 22. A timing diagram is shown in Figure 4. All data should be written MSB first.

Chip Address R/W

The LSB of the first byte of an SPI transaction is a R/W bit. This bit determines whether the communication is a read (Logic Level 1) or a write (Logic Level 0). This format is shown in Table 21.

Table 21. ADAU1961 SPI Address and Read/Write Byte Format

Bit 0	Bit 1	Bit 2	Bit 3	Bit 4	Bit 5	Bit 6	Bit 7
0	0	0	0	0	0	0	R/W

Subaddress

The 16-bit subaddress word is decoded into a location in one of the registers. This subaddress is the location of the appropriate register. The MSBs of the subaddress are zero-padded to bring the word to a full 2-byte length.

Data Bytes

The number of data bytes varies according to the register being accessed. During a burst mode write, an initial subaddress is written followed by a continuous sequence of data for consecutive register locations.

A sample timing diagram for a single-word SPI write operation to a register is shown in Figure 54. A sample timing diagram of a single-word SPI read operation is shown in Figure 55. The COUT pin goes from being three-state to being driven at the beginning of Byte 3. In this example, Byte 0 to Byte 2 contain the addresses and R/W bit, and subsequent bytes carry the data.

Table 22. Generic Control Word Format

Byte 0	Byte 1	Byte 2	Byte 3	Byte 4 ¹
chip_addr[6:0], R/W	subaddr[15:8]	subaddr[7:0]	data	data

¹ Continues to end of data.

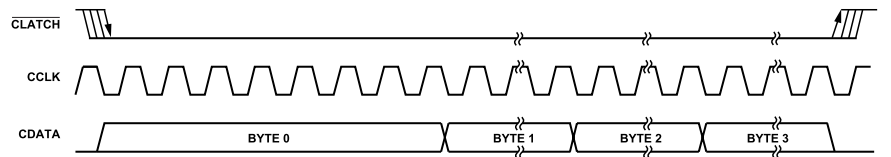

Figure 54. SPI Write to ADAU1961 Clocking (Single-Word Write Mode)

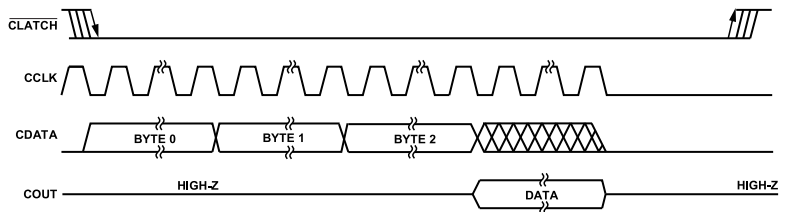

Figure 55. SPI Read from ADAU1961 Clocking (Single-Word Read Mode)

SERIAL DATA INPUT/OUTPUT PORTS

The flexible serial data input and output ports of the ADAU1961 can be set to accept or transmit data in 2-channel format or in a 4-channel TDM stream to interface to external ADCs or DACs. Data is processed in twos complement, MSB first format. The left channel data field always precedes the right channel data field in 2-channel streams. In TDM mode, Slot 0 and Slot 1 are in the first half of the audio frame, and Slot 2 and Slot 3 are in the second half of the frame. The serial modes and the position of the data in the frame are set in Register R15 to Register R18 (serial port and converter control registers, Address 0x4015 to Address 0x4018).

If the PLL of the ADAU1961 is not used, the serial data clocks must be synchronous with the ADAU1961 main clock input. The LRCLK and BCLK pins are used to clock both the serial input and output ports. The ADAU1961 can be set as the main or the subordinate in a system. Because there is only one set of serial data clocks, the input and output ports must always be both main or both subordinate.

Register R15 and Register R16 (serial port control registers, Address 0x4015 and Address 0x4016) allow control of clock polarity and data input modes. The valid data formats are I²S, left-justified, right-justified (24-/20-/18-/16-bit), and TDM. In all modes except for the right-justified modes, the serial port inputs an arbitrary number of bits up to a limit of 24. Extra bits do not cause an error, but they are truncated internally.

The serial port can operate with an arbitrary number of BCLK transitions in each LRCLK frame. The LRCLK in TDM mode can be

input to the ADAU1961 either as a 50% duty cycle clock or as a bit-wide pulse.

When the LRCLK is set as a pulse, a 47 pF capacitor should be connected between the LRCLK pin and ground (see Figure 56). This capacitor is necessary in both main and subordinate modes to properly align the LRCLK signal to the serial data stream.

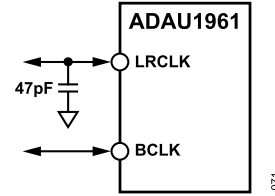

Figure 56. LRCLK Capacitor Alignment, TDM Pulse Mode

In TDM mode, the ADAU1961 can be a main for f_s up to 48 kHz. Table 23 lists the modes in which the serial output port can function.

Table 23. Serial Output Port Main/Subordinate Mode Capabilities

f_s	2-Channel Modes (I ² S, Left-Justified, Right-Justified)	4-Channel TDM
48 kHz	Main and subordinate	Main and subordinate
96 kHz	Main and subordinate	Subordinate

Table 24 describes the proper configurations for standard audio data formats.

Table 24. Data Format Configurations

Format	LRCLK Polarity (LRPOL)	LRCLK Mode (LRMOD)	BCLK Polarity (BPOL)	BCLK Cycles/Audio Frame (BPF[2:0])	Data Delay from LRCLK Edge (LRDEL[1:0])
I ² S (see Figure 57)	Frame begins on falling edge	50% duty cycle	Data changes on falling edge	32 to 64	Delayed from LRCLK edge by 1 BCLK
Left-Justified (see Figure 58)	Frame begins on rising edge	50% duty cycle	Data changes on falling edge	32 to 64	Aligned with LRCLK edge
Right-Justified (see Figure 59)	Frame begins on rising edge	50% duty cycle	Data changes on falling edge	32 to 64	Delayed from LRCLK edge by 8 or 16 BCLKs
TDM with Clock (see Figure 60)	Frame begins on falling edge	50% duty cycle	Data changes on falling edge	64 to 128	Delayed from start of word clock by 1 BCLK
TDM with Pulse (see Figure 61)	Frame begins on rising edge	Pulse	Data changes on falling edge	64 to 128	Delayed from start of word clock by 1 BCLK

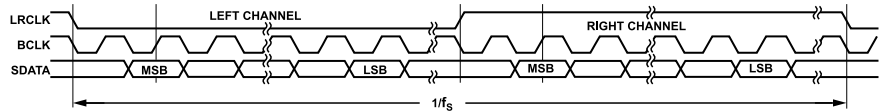

Figure 57. I²S Mode—16 Bits to 24 Bits per Channel

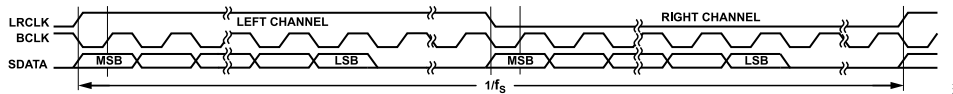

Figure 58. Left-Justified Mode—16 Bits to 24 Bits per Channel

SERIAL DATA INPUT/OUTPUT PORTS

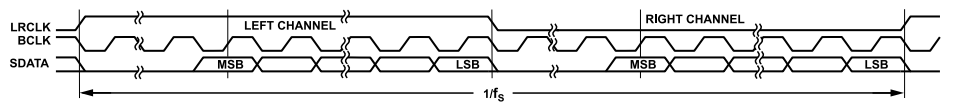

Figure 59. Right-Justified Mode—16 Bits to 24 Bits per Channel

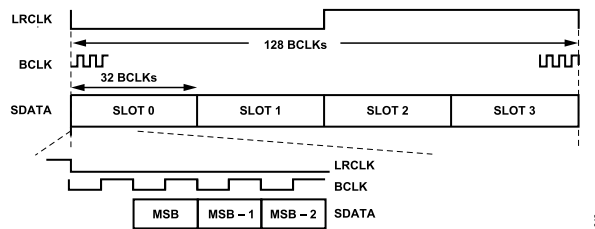

Figure 60. TDM 4 Mode

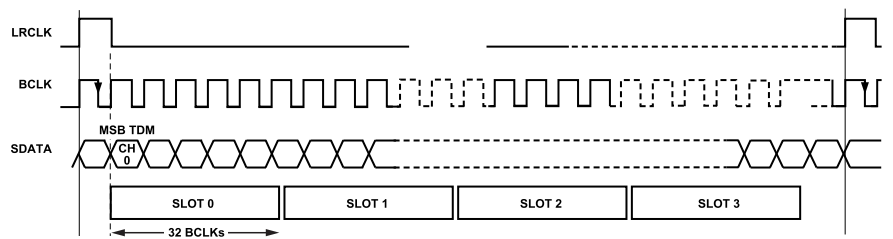

Figure 61. TDM 4 Mode with Pulse Word Clock

APPLICATIONS INFORMATION

POWER SUPPLY BYPASS CAPACITORS

Each analog and digital power supply pin should be bypassed to its nearest appropriate ground pin with a single 100 nF capacitor. The connections to each side of the capacitor should be as short as possible, and the trace should stay on a single layer with no vias. For maximum effectiveness, locate the capacitor equidistant from the power and ground pins or, when equidistant placement is not possible, slightly closer to the power pin. Thermal connections to the ground planes should be made on the far side of the capacitor.

Each supply signal on the board should also be bypassed with a single bulk capacitor (10 μF to 47 μF).

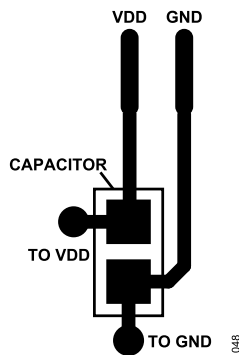

Figure 62. Recommended Power Supply Bypass Capacitor Layout

GSM NOISE FILTER

In mobile phone applications, excessive 217 Hz GSM noise on the analog supply pins can degrade the audio quality. To avoid this problem, it is recommended that an L-C filter be used in series with the bypass capacitors for the AVDD pins. This filter should consist of a 1.2 nH inductor and a 9.1 pF capacitor in series between AVDD and ground, as shown in Figure 63.

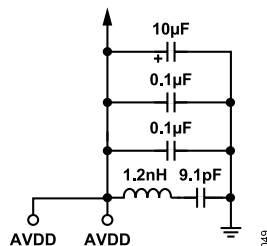

Figure 63. GSM Filter on the Analog Supply Pins

GROUNDING

A single ground plane should be used in the application layout. Components in an analog signal path should be placed away from digital signals.

EXPOSED PAD PCB DESIGN

The ADAU1961 has an exposed pad on the underside of the LFCSP. This pad is used to couple the package to the PCB for heat dissipation when using the outputs to drive earpiece or headphone loads. When designing a board for the ADAU1961, special consideration should be given to the following:

- ▶ A copper layer equal in size to the exposed pad should be on all layers of the board, from top to bottom, and should connect somewhere to a dedicated copper board layer (see Figure 64).
- ▶ Vias should be placed to connect all layers of copper, allowing for efficient heat and energy conductivity. For an example, see Figure 65, which has nine vias arranged in a 3 inch \times 3 inch grid in the pad area.

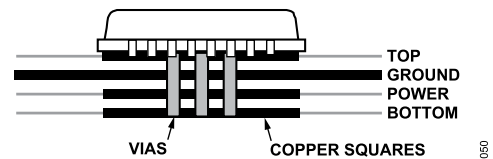

Figure 64. Exposed Pad Layout Example, Side View

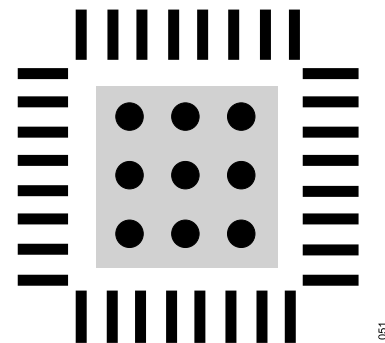

Figure 65. Exposed Pad Layout Example, Top View

CONTROL REGISTERS

Table 25. Register Map

Reg	Address	Name	Bit 7	Bit 6	Bit 5	Bit 4	Bit 3	Bit 2	Bit 1	Bit 0	Default	
R0	0x4000	Clock control	Reserved				CLKSRC	INFREQ[1:0]		COREN	00000000	
R1	0x4002	PLL control	M[15:8]						00000000			
			M[7:0]						11111101			
			N[15:8]						00000000			
			N[7:0]						00001100			
			Reserved	R[3:0]		X[1:0]		Type	00010000			
Reserved						Lock	PLLEN	00000000				
R2	0x4008	Dig mic/jack detect	JDDB[1:0]		JDFUNC[1:0]		Reserved		JDPOL	00000000		
R3	0x4009	Reserved	Reserved									00000000
R4	0x400A	Rec Mixer Left 0	Reserved	LINPG[2:0]			LINNG[2:0]			MX1EN	00000000	
R5	0x400B	Rec Mixer Left 1	Reserved			LDBOOST[1:0]		MX1AUXG[2:0]			00000000	
R6	0x400C	Rec Mixer Right 0	Reserved	RINPG[2:0]			RINNG[2:0]			MX2EN	00000000	
R7	0x400D	Rec Mixer Right 1	Reserved			RDBOOST[1:0]		MX2AUXG[2:0]			00000000	
R8	0x400E	Left diff input vol	LDVOL[5:0]						LDMUTE	LDEN	00000000	
R9	0x400F	Right diff input vol	RDVOL[5:0]						RDMUTE	RDEN	00000000	
R10	0x4010	Record mic bias	Reserved				MPERF	MBI	Reserved	MBIEN	00000000	
R11	0x4011	ALC 0	PGASLEW[1:0]		ALCMAX[2:0]		ALCSEL[2:0]			00000000		
R12	0x4012	ALC 1	ALCHOLD[3:0]				ALCTARG[3:0]			00000000		
R13	0x4013	ALC 2	ALCATCK[3:0]				ALCDEC[3:0]			00000000		
R14	0x4014	ALC 3	NGTYP[1:0]		NGEN		NGTHR[4:0]			00000000		
R15	0x4015	Serial Port 0	DITHEM	Reserved	LRMOD	BPOL	LRPOL	CHPF[1:0]		MS	00000000	
R16	0x4016	Serial Port 1	BPF[2:0]			ADTDM	DATDM	MSBP	LRDEL[1:0]		00000000	
R17	0x4017	Converter 0	Reserved	DAPAIR[1:0]		DAOSR	ADOSR	CONVSR[2:0]			00000000	
R18	0x4018	Converter 1	Reserved							ADPAIR[1:0]		00000000
R19	0x4019	ADC control	Reserved	ADCPOL	HPF	DMPOL	DMSW	INSEL	ADCEN[1:0]		00010000	
R20	0x401A	Left digital vol	LADVOL[7:0]						00000000			
R21	0x401B	Right digital vol	RADVOL[7:0]						00000000			
R22	0x401C	Play Mixer Left 0	Reserved	MX3RM	MX3LM	MX3AUXG[3:0]			MX3EN	00000000		
R23	0x401D	Play Mixer Left 1	MX3G2[3:0]				MX3G1[3:0]			00000000		
R24	0x401E	Play Mixer Right 0	Reserved	MX4RM	MX4LM	MX4AUXG[3:0]			MX4EN	00000000		
R25	0x401F	Play Mixer Right 1	MX4G2[3:0]				MX4G1[3:0]			00000000		
R26	0x4020	Play L/R mixer left	Reserved			MX5G4[1:0]		MX5G3[1:0]		MX5EN	00000000	
R27	0x4021	Play L/R mixer right	Reserved			MX6G4[1:0]		MX6G3[1:0]		MX6EN	00000000	
R28	0x4022	Play L/R mixer mono	Reserved					MX7[1:0]		MX7EN	00000000	
R29	0x4023	Play HP left vol	LHPVOL[5:0]						LHPM	HPEN	00000010	
R30	0x4024	Play HP right vol	RHPVOL[5:0]						RHPM	HPMODE	00000010	
R31	0x4025	Line output left vol	LOUTVOL[5:0]						LOUTM	LOMODE	00000010	
R32	0x4026	Line output right vol	ROUTVOL[5:0]						ROUTM	ROMODE	00000010	
R33	0x4027	Play mono output	MONOVOL[5:0]						MONOM	MOMODE	00000010	
R34	0x4028	Pop/click suppress	Reserved			POPMODE	POPLESS	ASLEW[1:0]		Reserved	00000000	
R35	0x4029	Play power mgmt	Reserved							PREN	PLEN	00000000
R36	0x402A	DAC Control 0	DACMONO[1:0]		DACPOL	Reserved		DEMPH	DACEN[1:0]		00000000	
R37	0x402B	DAC Control 1	LDAVOL[7:0]						00000000			
R38	0x402C	DAC Control 2	RDAVOL[7:0]						00000000			

CONTROL REGISTERS

Table 25. Register Map (Continued)

Reg	Address	Name	Bit 7	Bit 6	Bit 5	Bit 4	Bit 3	Bit 2	Bit 1	Bit 0	Default	
R39	0x402D	Serial port pad	ADCSDP[1:0]		DACSDP[1:0]		LRCLKP[1:0]		BCLKP[1:0]		10101010	
R40	0x402F	Control Port Pad 0	CDATP[1:0]		CLCHP[1:0]		SCLP[1:0]		SDAP[1:0]		10101010	
R41	0x4030	Control Port Pad 1	Reserved							SDASTR		00000000
R42	0x4031	Jack detect pin	Reserved		JDSTR	Reserved		JDP[1:0]		Reserved		00001000
R67	0x4036	Dejitter control	DEJIT[7:0]									00000011

CONTROL REGISTER DETAILS

All registers except for the PLL control register are 1-byte write and read registers.

R0: Clock Control, 16,384 (0x4000)

Bit 7	Bit 6	Bit 5	Bit 4	Bit 3	Bit 2	Bit 1	Bit 0
Reserved				CLKSRC	INFREQ[1:0]		COREN

Table 26. Clock Control Register

Bits	Bit Name	Description										
3	CLKSRC	Clock source select. 0 = direct from MCLK pin (default). 1 = PLL clock.										
[2:1]	INFREQ[1:0]	Input clock frequency. Sets the core clock rate that generates the core clock. If the PLL is used, this value is automatically set to $1024 \times f_S$. <table border="1" style="width: 100%; border-collapse: collapse;"> <thead> <tr> <th>Setting</th> <th>Input Clock Frequency</th> </tr> </thead> <tbody> <tr> <td>00</td> <td>$256 \times f_S$ (default)</td> </tr> <tr> <td>01</td> <td>$512 \times f_S$</td> </tr> <tr> <td>10</td> <td>$768 \times f_S$</td> </tr> <tr> <td>11</td> <td>$1024 \times f_S$</td> </tr> </tbody> </table>	Setting	Input Clock Frequency	00	$256 \times f_S$ (default)	01	$512 \times f_S$	10	$768 \times f_S$	11	$1024 \times f_S$
Setting	Input Clock Frequency											
00	$256 \times f_S$ (default)											
01	$512 \times f_S$											
10	$768 \times f_S$											
11	$1024 \times f_S$											
0	COREN	Core clock enable. Only the R0 and R1 registers can be accessed when this bit is set to 0 (core clock disabled). 0 = core clock disabled (default). 1 = core clock enabled.										

R1: PLL Control, 16,386 (0x4002)

Byte	Bit 7	Bit 6	Bit 5	Bit 4	Bit 3	Bit 2	Bit 1	Bit 0
0					M[15:8]			
1					M[7:0]			
2					N[15:8]			
3					N[7:0]			
4	Reserved		R[3:0]		X[1:0]		Type	
5	Reserved						Lock	PLLEN

Table 27. PLL Control Register

Byte	Bits	Bit Name	Description									
0	[7:0]	M[15:8]	PLL denominator MSB. This value is concatenated with M[7:0] to make up a 16-bit number.									
1	[7:0]	M[7:0]	PLL denominator LSB. This value is concatenated with M[15:8] to make up a 16-bit number. <table border="1" style="width: 100%; border-collapse: collapse;"> <thead> <tr> <th>M[15:8] (MSB)</th> <th>M[7:0] (LSB)</th> <th>Value of M</th> </tr> </thead> <tbody> <tr> <td>00000000</td> <td>00000000</td> <td>0</td> </tr> <tr> <td>...</td> <td>...</td> <td>...</td> </tr> </tbody> </table>	M[15:8] (MSB)	M[7:0] (LSB)	Value of M	00000000	00000000	0
M[15:8] (MSB)	M[7:0] (LSB)	Value of M										
00000000	00000000	0										
...										

CONTROL REGISTERS

Table 27. PLL Control Register (Continued)

Byte	Bits	Bit Name	Description
			00000000 11111101 253 (default) 11111111 11111111 65,535
2	[7:0]	N[15:8]	PLL numerator MSB. This value is concatenated with N[7:0] to make up a 16-bit number.
3	[7:0]	N[7:0]	PLL numerator LSB. This value is concatenated with N[15:8] to make up a 16-bit number.
			N[15:8] (MSB) N[7:0] (LSB) Value of N
			00000000 00000000 0 00000000 00001100 12 (default) 11111111 11111111 65,535
4	[6:3]	R[3:0]	PLL integer setting.
			Setting Value of R
			0010 2 (default) 0011 3 0100 4 0101 5 0110 6 0111 7 1000 8
4	[2:1]	X[1:0]	PLL input clock divider.
			Setting Value of X
			00 1 (default) 01 2 10 3 11 4
4	0	Type	Type of PLL. When set to integer mode, the values of M and N are ignored. 0 = integer (default). 1 = fractional.
5	1	Lock	PLL lock. This read-only bit is flagged when the PLL has finished locking. 0 = PLL unlocked (default). 1 = PLL locked.
5	0	PLLEN	PLL enable. 0 = PLL disabled (default). 1 = PLL enabled.

R2: Digital Microphone/Jack Detection Control, 16,392 (0x4008)

Bit 7	Bit 6	Bit 5	Bit 4	Bit 3	Bit 2	Bit 1	Bit 0
	JDDB[1:0]		JDFUNC[1:0]		Reserved		JDPOL

Table 28. Digital Microphone/Jack Detection Control Register

Bits	Bit Name	Description
[7:6]	JDDB[1:0]	Jack detect debounce time.
		Setting Debounce Time
		00 5 ms (default)
		01 10 ms
		10 20 ms

CONTROL REGISTERS

Table 28. Digital Microphone/Jack Detection Control Register (Continued)

Bits	Bit Name	Description
		11 40 ms
[5:4]	JDFUNC[1:0]	JACKDET/MICIN pin function. Enables or disables the jack detect function or configures the pin for a digital microphone input.
		Setting Pin Function
		00 Jack detect off (default)
		01 Jack detect on
		10 Digital microphone input
		11 Reserved
0	JDPOL	Jack detect polarity. Detects high or low signal. 0 = detect high signal (default). 1 = detect low signal.

R4: Record Mixer Left (Mixer 1) Control 0, 16,394 (0x400A)

This register controls the gain of single-ended inputs for the left channel record path. The left channel record mixer is referred to as Mixer 1.

Bit 7	Bit 6	Bit 5	Bit 4	Bit 3	Bit 2	Bit 1	Bit 0
Reserved	LINPG[2:0]			LINNG[2:0]			MX1EN

Table 29. Record Mixer Left (Mixer 1) Control 0 Register

Bits	Bit Name	Description
[6:4]	LINPG[2:0]	Gain for a left channel single-ended input from the LIMP pin, input to Mixer 1.
		Setting Gain
		000 Mute (default)
		001 -12 dB
		010 -9 dB
		011 -6 dB
		100 -3 dB
		101 0 dB
		110 3 dB
		111 6 dB
[3:1]	LINNG[2:0]	Gain for a left channel single-ended input from the LINN pin, input to Mixer 1.
		Setting Gain
		000 Mute (default)
		001 -12 dB
		010 -9 dB
		011 -6 dB
		100 -3 dB
		101 0 dB
		110 3 dB
		111 6 dB
0	MX1EN	Left channel mixer enable in the record path. Referred to as Mixer 1. 0 = mixer disabled (default). 1 = mixer enabled.

R5: Record Mixer Left (Mixer 1) Control 1, 16,395 (0x400B)

This register controls the gain boost of the left channel differential PGA input and the gain for the left channel auxiliary input in the record path. The left channel record mixer is referred to as Mixer 1.

CONTROL REGISTERS

Bit 7	Bit 6	Bit 5	Bit 4	Bit 3	Bit 2	Bit 1	Bit 0
	Reserved		LDBOOST[1:0]		MX1AUXG[2:0]		

Table 30. Record Mixer Left (Mixer 1) Control 1 Register

Bits	Bit Name	Description	
[4:3]	LDBOOST[1:0]	Left channel differential PGA input gain boost, input to Mixer 1. The left differential input uses the LINP (positive signal) and LINN (negative signal) pins.	
		Setting	Gain Boost
		00	Mute (default)
		01	0 dB
		10	20 dB
[2:0]	MX1AUXG[2:0]	Left single-ended auxiliary input gain from the LAUX pin in the record path, input to Mixer 1.	
		Setting	Auxiliary Input Gain
		000	Mute (default)
		001	-12 dB
		010	-9 dB
		011	-6 dB
		100	-3 dB
		101	0 dB
		110	3 dB
		111	6 dB

R6: Record Mixer Right (Mixer 2) Control 0, 16,396 (0x400C)

This register controls the gain of single-ended inputs for the right channel record path. The right channel record mixer is referred to as Mixer 2.

Bit 7	Bit 6	Bit 5	Bit 4	Bit 3	Bit 2	Bit 1	Bit 0
Reserved	RINPG[2:0]		RINNG[2:0]		MX2EN		

Table 31. Record Mixer Right (Mixer 2) Control 0 Register

Bits	Bit Name	Description	
[6:4]	RINPG[2:0]	Gain for a right channel single-ended input from the RINP pin, input to Mixer 2.	
		Setting	Gain
		000	Mute (default)
		001	-12 dB
		010	-9 dB
		011	-6 dB
		100	-3 dB
		101	0 dB
		110	3 dB
		111	6 dB
[3:1]	RINNG[2:0]	Gain for a right channel single-ended input from the RINN pin, input to Mixer 2.	
		Setting	Gain
		000	Mute (default)
		001	-12 dB
		010	-9 dB
		011	-6 dB
		100	-3 dB
101	0 dB		

CONTROL REGISTERS

Table 33. Left Differential Input Volume Control Register (Continued)

Bits	Bit Name	Description
		... 010000 0 dB ... 111110 34.5 dB 111111 35.25 dB
1	LDMUTE	Left differential input mute control. 0 = mute (default). 1 = unmute.
0	LDEN	Left differential PGA enable. When enabled, the LINP and LINN pins are used as a full differential pair. When disabled, these two pins are configured as two single-ended inputs with the signals routed around the PGA. 0 = disabled (default). 1 = enabled.

R9: Right Differential Input Volume Control, 16,399 (0x400F)

This register enables the differential path and sets the volume control for the right differential PGA input.

Bit 7	Bit 6	Bit 5	Bit 4	Bit 3	Bit 2	Bit 1	Bit 0
RDVOL[5:0]						RDMUTE	RDEN

Table 34. Right Differential Input Volume Control Register

Bits	Bit Name	Description
[7:2]	RDVOL[5:0]	Right channel differential PGA input volume control. The right differential input uses the RINP (positive signal) and RINN (negative signal) pins. Each step corresponds to a 0.75 dB increase in gain. See Table 69 for a complete list of the volume settings.
		Setting Volume
		000000 -12 dB (default)
		000001 -11.25 dB
	
		010000 0 dB
	
		111110 34.5 dB
		111111 35.25 dB
1	RDMUTE	Right differential input mute control. 0 = mute (default). 1 = unmute.
0	RDEN	Right differential PGA enable. When enabled, the RINP and RINN pins are used as a full differential pair. When disabled, these two pins are configured as two single-ended inputs with the signals routed around the PGA. 0 = disabled (default). 1 = enabled.

R10: Record Microphone Bias Control, 16,400 (0x4010)

This register controls the MICBIAS pin settings for biasing electret type analog microphones.

Bit 7	Bit 6	Bit 5	Bit 4	Bit 3	Bit 2	Bit 1	Bit 0
Reserved				MPERF	MBI	Reserved	MBIEN

CONTROL REGISTERS

Table 35. Record Microphone Bias Control Register

Bits	Bit Name	Description
3	MPERF	Microphone bias is enabled for high performance or normal operation. High performance operation sources more current to the microphone. 0 = normal operation (default). 1 = high performance.
2	MBI	Microphone voltage bias as a fraction of AVDD. 0 = $0.90 \times AVDD$ (default). 1 = $0.65 \times AVDD$.
0	MBIEN	Enables the MICBIAS output. 0 = disabled (default). 1 = enabled.

R11: ALC Control 0, 16,401 (0x4011)

Bit 7	Bit 6	Bit 5	Bit 4	Bit 3	Bit 2	Bit 1	Bit 0
	PGASLEW[1:0]		ALCMAX[2:0]			ALCSEL[2:0]	

Table 36. ALC Control 0 Register

Bits	Bit Name	Description																		
[7:6]	PGASLEW[1:0]	PGA volume slew time when the ALC is off. The slew time is the period of time that a volume increase or decrease takes to ramp up or ramp down to the target volume set in Register R8 (left differential input volume control) and Register R9 (right differential input volume control). <table border="1"> <thead> <tr> <th>Setting</th> <th>Slew Time</th> </tr> </thead> <tbody> <tr> <td>00</td> <td>24 ms (default)</td> </tr> <tr> <td>01</td> <td>48 ms</td> </tr> <tr> <td>10</td> <td>96 ms</td> </tr> <tr> <td>11</td> <td>Off</td> </tr> </tbody> </table>	Setting	Slew Time	00	24 ms (default)	01	48 ms	10	96 ms	11	Off								
Setting	Slew Time																			
00	24 ms (default)																			
01	48 ms																			
10	96 ms																			
11	Off																			
[5:3]	ALCMAX[2:0]	The maximum ALC gain sets a limit to the amount of gain that the ALC can provide to the input signal. This protects small signals from excessive amplification. <table border="1"> <thead> <tr> <th>Setting</th> <th>Maximum ALC Gain</th> </tr> </thead> <tbody> <tr> <td>000</td> <td>-12 dB (default)</td> </tr> <tr> <td>001</td> <td>-6 dB</td> </tr> <tr> <td>010</td> <td>0 dB</td> </tr> <tr> <td>011</td> <td>6 dB</td> </tr> <tr> <td>100</td> <td>12 dB</td> </tr> <tr> <td>101</td> <td>18 dB</td> </tr> <tr> <td>110</td> <td>24 dB</td> </tr> <tr> <td>111</td> <td>30 dB</td> </tr> </tbody> </table>	Setting	Maximum ALC Gain	000	-12 dB (default)	001	-6 dB	010	0 dB	011	6 dB	100	12 dB	101	18 dB	110	24 dB	111	30 dB
Setting	Maximum ALC Gain																			
000	-12 dB (default)																			
001	-6 dB																			
010	0 dB																			
011	6 dB																			
100	12 dB																			
101	18 dB																			
110	24 dB																			
111	30 dB																			
[2:0]	ALCSEL[2:0]	ALC select. These bits set the channels that are controlled by the ALC. When set to right only, the ALC responds only to the right channel input and controls the gain of the right PGA amplifier only. When set to left only, the ALC responds only to the left channel input and controls the gain of the left PGA amplifier only. When set to stereo, the ALC responds to the greater of the left or right channel and controls the gain of both the left and right PGA amplifiers. These bits must be off if manual control of the volume is desired. <table border="1"> <thead> <tr> <th>Setting</th> <th>Channels</th> </tr> </thead> <tbody> <tr> <td>000</td> <td>Off (default)</td> </tr> <tr> <td>001</td> <td>Right only</td> </tr> <tr> <td>010</td> <td>Left only</td> </tr> <tr> <td>011</td> <td>Stereo</td> </tr> <tr> <td>100</td> <td>Reserved</td> </tr> <tr> <td>101</td> <td>Reserved</td> </tr> <tr> <td>110</td> <td>Reserved</td> </tr> </tbody> </table>	Setting	Channels	000	Off (default)	001	Right only	010	Left only	011	Stereo	100	Reserved	101	Reserved	110	Reserved		
Setting	Channels																			
000	Off (default)																			
001	Right only																			
010	Left only																			
011	Stereo																			
100	Reserved																			
101	Reserved																			
110	Reserved																			

CONTROL REGISTERS

Table 36. ALC Control 0 Register (Continued)

Bits	Bit Name	Description
	111	Reserved

R12: ALC Control 1, 16,402 (0x4012)

Bit 7	Bit 6	Bit 5	Bit 4	Bit 3	Bit 2	Bit 1	Bit 0
ALCHOLD[3:0]				ALCTARG[3:0]			

Table 37. ALC Control 1 Register

Bits	Bit Name	Description																																		
[7:4]	ALCHOLD[3:0]	ALC hold time. The ALC hold time is the amount of time that the ALC waits after a decrease in input level before increasing the gain to achieve the target level. The recommended minimum setting is 21 ms (0011) to prevent distortion of low frequency signals. The hold time doubles with every 1-bit increase.																																		
		<table border="1"> <thead> <tr> <th>Setting</th> <th>Hold Time</th> </tr> </thead> <tbody> <tr><td>0000</td><td>2.67 ms (default)</td></tr> <tr><td>0001</td><td>5.34 ms</td></tr> <tr><td>0010</td><td>10.68 ms</td></tr> <tr><td>0011</td><td>21.36 ms</td></tr> <tr><td>0100</td><td>42.72 ms</td></tr> <tr><td>0101</td><td>85.44 ms</td></tr> <tr><td>0110</td><td>170.88 ms</td></tr> <tr><td>0111</td><td>341.76 ms</td></tr> <tr><td>1000</td><td>683.52 ms</td></tr> <tr><td>1001</td><td>1.367 sec</td></tr> <tr><td>1010</td><td>2.7341 sec</td></tr> <tr><td>1011</td><td>5.4682 sec</td></tr> <tr><td>1100</td><td>10.936 sec</td></tr> <tr><td>1101</td><td>21.873 sec</td></tr> <tr><td>1110</td><td>43.745 sec</td></tr> <tr><td>1111</td><td>87.491 sec</td></tr> </tbody> </table>	Setting	Hold Time	0000	2.67 ms (default)	0001	5.34 ms	0010	10.68 ms	0011	21.36 ms	0100	42.72 ms	0101	85.44 ms	0110	170.88 ms	0111	341.76 ms	1000	683.52 ms	1001	1.367 sec	1010	2.7341 sec	1011	5.4682 sec	1100	10.936 sec	1101	21.873 sec	1110	43.745 sec	1111	87.491 sec
Setting	Hold Time																																			
0000	2.67 ms (default)																																			
0001	5.34 ms																																			
0010	10.68 ms																																			
0011	21.36 ms																																			
0100	42.72 ms																																			
0101	85.44 ms																																			
0110	170.88 ms																																			
0111	341.76 ms																																			
1000	683.52 ms																																			
1001	1.367 sec																																			
1010	2.7341 sec																																			
1011	5.4682 sec																																			
1100	10.936 sec																																			
1101	21.873 sec																																			
1110	43.745 sec																																			
1111	87.491 sec																																			
[3:0]	ALCTARG[3:0]	ALC target. The ALC target sets the desired ADC input level. The PGA gain is adjusted by the ALC to reach this target level. The recommended target level is between -16 dB and -10 dB to accommodate transients without clipping the ADC.																																		
		<table border="1"> <thead> <tr> <th>Setting</th> <th>ALC Target</th> </tr> </thead> <tbody> <tr><td>0000</td><td>-28.5 dB (default)</td></tr> <tr><td>0001</td><td>-27 dB</td></tr> <tr><td>0010</td><td>-25.5 dB</td></tr> <tr><td>0011</td><td>-24 dB</td></tr> <tr><td>0100</td><td>-22.5 dB</td></tr> <tr><td>0101</td><td>-21 dB</td></tr> <tr><td>0110</td><td>-19.5 dB</td></tr> <tr><td>0111</td><td>-18 dB</td></tr> <tr><td>1000</td><td>-16.5 dB</td></tr> <tr><td>1001</td><td>-15 dB</td></tr> <tr><td>1010</td><td>-13.5 dB</td></tr> <tr><td>1011</td><td>-12 dB</td></tr> <tr><td>1100</td><td>-10.5 dB</td></tr> <tr><td>1101</td><td>-9 dB</td></tr> <tr><td>1110</td><td>-7.5 dB</td></tr> <tr><td>1111</td><td>-6 dB</td></tr> </tbody> </table>	Setting	ALC Target	0000	-28.5 dB (default)	0001	-27 dB	0010	-25.5 dB	0011	-24 dB	0100	-22.5 dB	0101	-21 dB	0110	-19.5 dB	0111	-18 dB	1000	-16.5 dB	1001	-15 dB	1010	-13.5 dB	1011	-12 dB	1100	-10.5 dB	1101	-9 dB	1110	-7.5 dB	1111	-6 dB
Setting	ALC Target																																			
0000	-28.5 dB (default)																																			
0001	-27 dB																																			
0010	-25.5 dB																																			
0011	-24 dB																																			
0100	-22.5 dB																																			
0101	-21 dB																																			
0110	-19.5 dB																																			
0111	-18 dB																																			
1000	-16.5 dB																																			
1001	-15 dB																																			
1010	-13.5 dB																																			
1011	-12 dB																																			
1100	-10.5 dB																																			
1101	-9 dB																																			
1110	-7.5 dB																																			
1111	-6 dB																																			

CONTROL REGISTERS

R13: ALC Control 2, 16,403 (0x4013)

Bit 7	Bit 6	Bit 5	Bit 4	Bit 3	Bit 2	Bit 1	Bit 0
ALCATCK[3:0]				ALCDEC[3:0]			

Table 38. ALC Control 2 Register

Bits	Bit Name	Description																																		
[7:4]	ALCATCK[3:0]	ALC attack time. The attack time sets how fast the ALC starts attenuating after an increase in input level above the target. A typical setting for music recording is 384 ms, and a typical setting for voice recording is 24 ms.																																		
		<table border="1"> <thead> <tr> <th>Setting</th> <th>Attack Time</th> </tr> </thead> <tbody> <tr><td>0000</td><td>6 ms (default)</td></tr> <tr><td>0001</td><td>12 ms</td></tr> <tr><td>0010</td><td>24 ms</td></tr> <tr><td>0011</td><td>48 ms</td></tr> <tr><td>0100</td><td>96 ms</td></tr> <tr><td>0101</td><td>192 ms</td></tr> <tr><td>0110</td><td>384 ms</td></tr> <tr><td>0111</td><td>768 ms</td></tr> <tr><td>1000</td><td>1.54 sec</td></tr> <tr><td>1001</td><td>3.07 sec</td></tr> <tr><td>1010</td><td>6.14 sec</td></tr> <tr><td>1011</td><td>12.29 sec</td></tr> <tr><td>1100</td><td>24.58 sec</td></tr> <tr><td>1101</td><td>49.15 sec</td></tr> <tr><td>1110</td><td>98.30 sec</td></tr> <tr><td>1111</td><td>196.61 sec</td></tr> </tbody> </table>	Setting	Attack Time	0000	6 ms (default)	0001	12 ms	0010	24 ms	0011	48 ms	0100	96 ms	0101	192 ms	0110	384 ms	0111	768 ms	1000	1.54 sec	1001	3.07 sec	1010	6.14 sec	1011	12.29 sec	1100	24.58 sec	1101	49.15 sec	1110	98.30 sec	1111	196.61 sec
Setting	Attack Time																																			
0000	6 ms (default)																																			
0001	12 ms																																			
0010	24 ms																																			
0011	48 ms																																			
0100	96 ms																																			
0101	192 ms																																			
0110	384 ms																																			
0111	768 ms																																			
1000	1.54 sec																																			
1001	3.07 sec																																			
1010	6.14 sec																																			
1011	12.29 sec																																			
1100	24.58 sec																																			
1101	49.15 sec																																			
1110	98.30 sec																																			
1111	196.61 sec																																			
[3:0]	ALCDEC[3:0]	ALC decay time. The decay time sets how fast the ALC increases the PGA gain after a decrease in input level below the target. A typical setting for music recording is 24.58 seconds, and a typical setting for voice recording is 1.54 seconds.																																		
		<table border="1"> <thead> <tr> <th>Setting</th> <th>Decay Time</th> </tr> </thead> <tbody> <tr><td>0000</td><td>24 ms</td></tr> <tr><td>0001</td><td>48 ms</td></tr> <tr><td>0010</td><td>96 ms</td></tr> <tr><td>0011</td><td>192 ms</td></tr> <tr><td>0100</td><td>384 ms</td></tr> <tr><td>0101</td><td>768 ms</td></tr> <tr><td>0110</td><td>1.54 sec</td></tr> <tr><td>0111</td><td>3.07 sec</td></tr> <tr><td>1000</td><td>6.14 sec</td></tr> <tr><td>1001</td><td>12.29 sec</td></tr> <tr><td>1010</td><td>24.58 sec</td></tr> <tr><td>1011</td><td>49.15 sec</td></tr> <tr><td>1100</td><td>98.30 sec</td></tr> <tr><td>1101</td><td>196.61 sec</td></tr> <tr><td>1110</td><td>393.22 sec</td></tr> <tr><td>1111</td><td>786.43 sec</td></tr> </tbody> </table>	Setting	Decay Time	0000	24 ms	0001	48 ms	0010	96 ms	0011	192 ms	0100	384 ms	0101	768 ms	0110	1.54 sec	0111	3.07 sec	1000	6.14 sec	1001	12.29 sec	1010	24.58 sec	1011	49.15 sec	1100	98.30 sec	1101	196.61 sec	1110	393.22 sec	1111	786.43 sec
Setting	Decay Time																																			
0000	24 ms																																			
0001	48 ms																																			
0010	96 ms																																			
0011	192 ms																																			
0100	384 ms																																			
0101	768 ms																																			
0110	1.54 sec																																			
0111	3.07 sec																																			
1000	6.14 sec																																			
1001	12.29 sec																																			
1010	24.58 sec																																			
1011	49.15 sec																																			
1100	98.30 sec																																			
1101	196.61 sec																																			
1110	393.22 sec																																			
1111	786.43 sec																																			

R14: ALC Control 3, 16,404 (0x4014)

Bit 7	Bit 6	Bit 5	Bit 4	Bit 3	Bit 2	Bit 1	Bit 0
NGTYP[1:0]		NGEN		NGTHR[4:0]			

CONTROL REGISTERS

Table 39. ALC Control 3 Register

Bits	Bit Name	Description	
[7:6]	NGTYP[1:0]	Noise gate type. When the input signal falls below the threshold for 250 ms, the noise gate can hold a constant PGA gain, mute the ADC output, fade the PGA gain to the minimum gain value, or fade then mute.	
		Setting	Noise Gate
		00	Hold PGA constant (default)
		01	Mute ADC output (digital mute)
		10	Fade to PGA minimum value (analog fade)
	11	Fade then mute (analog fade/digital mute)	
5	NGEN	Noise gate enable. 0 = disabled (default). 1 = enabled.	
[4:0]	NGTHR[4:0]	Noise gate threshold. When the input signal falls below the threshold for 250 ms, the noise gate is activated. A 1 LSB increase corresponds to a -1.5 dB change. See Table 70 for a complete list of the threshold settings.	
		Setting	Threshold
		00000	-76.5 dB (default)
		00001	-75 dB
	
	11110	-31.5 dB	
	11111	-30 dB	

R15: Serial Port Control 0, 16,405 (0x4015)

Bit 7	Bit 6	Bit 5	Bit 4	Bit 3	Bit 2	Bit 1	Bit 0
DITHEN	Reserved	LRMOD	BPOL	LRPOL		CHPF[1:0]	MS

Table 40. Serial Port Control 0 Register

Bits	Bit Name	Description	
7	DITHEN	Dither enable is applicable only for 16-bit data width modes. 0 = disabled (default). 1 = enabled.	
5	LRMOD	LRCLK mode sets the LRCLK for either a 50% duty cycle or a pulse. The pulse mode should be at least 1 BCLK wide. 0 = 50% duty cycle (default). 1 = pulse mode.	
4	BPOL	BCLK polarity sets the BCLK edge that triggers a change in audio data. This can be set for the falling or rising edge of the BCLK. 0 = falling edge (default). 1 = rising edge.	
3	LRPOL	LRCLK polarity sets the LRCLK edge that triggers the beginning of the left channel audio frame. This can be set for the falling or rising edge of the LRCLK. 0 = falling edge (default). 1 = rising edge.	
[2:1]	CHPF[1:0]	Channels per frame sets the number of channels per LRCLK frame.	
		Setting	Channels per LRCLK Frame
		00	Stereo (default)
		01	TDM 4
		10	Reserved
	11	Reserved	
0	MS	Serial data port bus mode. Both LRCLK and BCLK are main of the serial port when set in main mode and are serial port subordinate in subordinate mode. 0 = subordinate mode (default).	

CONTROL REGISTERS

Table 40. Serial Port Control 0 Register (Continued)

Bits	Bit Name	Description
		1 = main mode.

R16: Serial Port Control 1, 16,406 (0x4016)

Bit 7	Bit 6	Bit 5	Bit 4	Bit 3	Bit 2	Bit 1	Bit 0
	BPF[2:0]		ADTDM	DATDM	MSBP		LRDEL[1:0]

Table 41. Serial Port Control 1 Register

Bits	Bit Name	Description
[7:5]	BPF[2:0]	Number of bit clock cycles per LRCLK audio frame. Setting 000 64 (default) 001 32 010 48 011 128 100 256 101 Reserved 110 Reserved 111 Reserved
4	ADTDM	ADC serial audio data channel position in TDM mode. 0 = left first (default). 1 = right first.
3	DATDM	DAC serial audio data channel position in TDM mode. 0 = left first (default). 1 = right first.
2	MSBP	MSB position in the LRCLK frame. 0 = MSB first (default). 1 = LSB first.
[1:0]	LRDEL[1:0]	Data delay from LRCLK edge (in BCLK units). Setting 00 1 (default) 01 0 10 8 11 16

R17: Converter Control 0, 16,407 (0x4017)

Bit 7	Bit 6	Bit 5	Bit 4	Bit 3	Bit 2	Bit 1	Bit 0
Reserved		DAPAIR[1:0]	DAOSR	ADOSR			CONVSR[2:0]

Table 42. Converter Control 0 Register

Bits	Bit Name	Description
[6:5]	DAPAIR[1:0]	On-chip DAC serial data selection in TDM mode. Setting 00 First pair (default) 01 Second pair 10 Third pair 11 Fourth pair

CONTROL REGISTERS

Table 42. Converter Control 0 Register (Continued)

Bits	Bit Name	Description																											
4	DAOSR	DAC oversampling ratio. This bit cannot be set for 64× when CONVSR[2:0] is set to 96 kHz. 0 = 128× (default). 1 = 64×.																											
3	ADOSR	ADC oversampling ratio. This bit cannot be set for 64× when CONVSR[2:0] is set to 96 kHz. 0 = 128× (default). 1 = 64×.																											
[2:0]	CONVSR[2:0]	Converter sampling rate. The ADCs and DACs operate at the sampling rate set in this register. The converter rate selected is a ratio of the base sampling rate, f_s . The base sampling rate is determined by the operating frequency of the core clock. The serial port mirrors the converter sampling rates set in this register.																											
		<table border="1"> <thead> <tr> <th>Setting</th> <th>Sampling Rate</th> <th>Base Sampling Rate ($f_s = 48$ kHz)</th> </tr> </thead> <tbody> <tr> <td>000</td> <td>f_s</td> <td>48 kHz, base (default)</td> </tr> <tr> <td>001</td> <td>$f_s/6$</td> <td>8 kHz</td> </tr> <tr> <td>010</td> <td>$f_s/4$</td> <td>12 kHz</td> </tr> <tr> <td>011</td> <td>$f_s/3$</td> <td>16 kHz</td> </tr> <tr> <td>100</td> <td>$f_s/2$</td> <td>24 kHz</td> </tr> <tr> <td>101</td> <td>$f_s/1.5$</td> <td>32 kHz</td> </tr> <tr> <td>110</td> <td>$f_s/0.5$</td> <td>96 kHz</td> </tr> <tr> <td>111</td> <td>Reserved</td> <td></td> </tr> </tbody> </table>	Setting	Sampling Rate	Base Sampling Rate ($f_s = 48$ kHz)	000	f_s	48 kHz, base (default)	001	$f_s/6$	8 kHz	010	$f_s/4$	12 kHz	011	$f_s/3$	16 kHz	100	$f_s/2$	24 kHz	101	$f_s/1.5$	32 kHz	110	$f_s/0.5$	96 kHz	111	Reserved	
Setting	Sampling Rate	Base Sampling Rate ($f_s = 48$ kHz)																											
000	f_s	48 kHz, base (default)																											
001	$f_s/6$	8 kHz																											
010	$f_s/4$	12 kHz																											
011	$f_s/3$	16 kHz																											
100	$f_s/2$	24 kHz																											
101	$f_s/1.5$	32 kHz																											
110	$f_s/0.5$	96 kHz																											
111	Reserved																												

R18: Converter Control 1, 16,408 (0x4018)

Bit 7	Bit 6	Bit 5	Bit 4	Bit 3	Bit 2	Bit 1	Bit 0
Reserved						ADPAIR[1:0]	

Table 43. Converter Control 1 Register

Bits	Bit Name	Description										
[1:0]	ADPAIR[1:0]	On-chip ADC serial data selection in TDM mode.										
		<table border="1"> <thead> <tr> <th>Setting</th> <th>Pair</th> </tr> </thead> <tbody> <tr> <td>00</td> <td>First pair (default)</td> </tr> <tr> <td>01</td> <td>Second pair</td> </tr> <tr> <td>10</td> <td>Third pair</td> </tr> <tr> <td>11</td> <td>Fourth pair</td> </tr> </tbody> </table>	Setting	Pair	00	First pair (default)	01	Second pair	10	Third pair	11	Fourth pair
Setting	Pair											
00	First pair (default)											
01	Second pair											
10	Third pair											
11	Fourth pair											

R19: ADC Control, 16,409 (0x4019)

Bit 7	Bit 6	Bit 5	Bit 4	Bit 3	Bit 2	Bit 1	Bit 0
Reserved	ADCPOL	HPF	DMPOL	DMSW	INSEL	ADCEN[1:0]	

Table 44. ADC Control Register

Bits	Bit Name	Description
6	ADCPOL	Invert input polarity. 0 = normal (default). 1 = inverted.
5	HPF	ADC high-pass filter select. At 48 kHz, $f_{3dB} = 2$ Hz. 0 = off (default). 1 = on.
4	DMPOL	Digital microphone data polarity swap. 0 = invert polarity.

CONTROL REGISTERS

Table 44. ADC Control Register (Continued)

Bits	Bit Name	Description
		1 = normal (default).
3	DMSW	Digital microphone channel swap. Normal operation sends the left channel on the rising edge of the clock and the right channel on the falling edge of the clock. 0 = normal (default). 1 = swap left and right channels.
2	INSEL	Digital microphone input select. When asserted, the on-chip ADCs are off, BCLK is main at $128 \times f_S$, and ADC_SDATA is expected to have left and right channels interleaved. 0 = digital microphone inputs off, ADCs enabled (default). 1 = digital microphone inputs enabled, ADCs off.
[1:0]	ADCEN[1:0]	ADC enable.
		Setting ADCs Enabled
		00 Both off (default)
		01 Left on
		10 Right on
		11 Both on

R20: Left Input Digital Volume, 16,410 (0x401A)

Bit 7	Bit 6	Bit 5	Bit 4	Bit 3	Bit 2	Bit 1	Bit 0
LADVOL[7:0]							

Table 45. Left Input Digital Volume Register

Bits	Bit Name	Description
[7:0]	LADVOL[7:0]	Controls the digital volume attenuation for left channel inputs from either the left ADC or the left digital microphone input. Each bit corresponds to a 0.375 dB step with slewing between settings. See Table 71 for a complete list of the volume settings.
		Setting Volume Attenuation
		00000000 0 dB (default)
		00000001 -0.375 dB
		00000010 -0.75 dB
		...
		11111110 -95.25 dB
		11111111 -95.625 dB

R21: Right Input Digital Volume, 16,411 (0x401B)

Bit 7	Bit 6	Bit 5	Bit 4	Bit 3	Bit 2	Bit 1	Bit 0
RADVOL[7:0]							

Table 46. Right Input Digital Volume Register

Bits	Bit Name	Description
[7:0]	RADVOL[7:0]	Controls the digital volume attenuation for right channel inputs from either the right ADC or the right digital microphone input. Each bit corresponds to a 0.375 dB step with slewing between settings. See Table 71 for a complete list of the volume settings.
		Setting Volume Attenuation
		00000000 0 dB (default)
		00000001 -0.375 dB
		00000010 -0.75 dB
		...
		11111110 -95.25 dB

CONTROL REGISTERS

Table 46. Right Input Digital Volume Register (Continued)

Bits	Bit Name	Description
		11111111 -95.625 dB

R22: Playback Mixer Left (Mixer 3) Control 0, 16,412 (0x401C)

Bit 7	Bit 6	Bit 5	Bit 4	Bit 3	Bit 2	Bit 1	Bit 0
Reserved	MX3RM	MX3LM			MX3AUXG[3:0]		MX3EN

Table 47. Playback Mixer Left (Mixer 3) Control 0 Register

Bits	Bit Name	Description																				
6	MX3RM	Mixer input mute. Mutes the right DAC input to the left channel playback mixer (Mixer 3). 0 = muted (default). 1 = unmuted.																				
5	MX3LM	Mixer input mute. Mutes the left DAC input to the left channel playback mixer (Mixer 3). 0 = muted (default). 1 = unmuted.																				
[4:1]	MX3AUXG[3:0]	Mixer input gain. Controls the left channel auxiliary input gain to the left channel playback mixer (Mixer 3). <table border="1"> <thead> <tr> <th>Setting</th> <th>Gain</th> </tr> </thead> <tbody> <tr><td>0000</td><td>Mute (default)</td></tr> <tr><td>0001</td><td>-15 dB</td></tr> <tr><td>0010</td><td>-12 dB</td></tr> <tr><td>0011</td><td>-9 dB</td></tr> <tr><td>0100</td><td>-6 dB</td></tr> <tr><td>0101</td><td>-3 dB</td></tr> <tr><td>0110</td><td>0 dB</td></tr> <tr><td>0111</td><td>3 dB</td></tr> <tr><td>1000</td><td>6 dB</td></tr> </tbody> </table>	Setting	Gain	0000	Mute (default)	0001	-15 dB	0010	-12 dB	0011	-9 dB	0100	-6 dB	0101	-3 dB	0110	0 dB	0111	3 dB	1000	6 dB
Setting	Gain																					
0000	Mute (default)																					
0001	-15 dB																					
0010	-12 dB																					
0011	-9 dB																					
0100	-6 dB																					
0101	-3 dB																					
0110	0 dB																					
0111	3 dB																					
1000	6 dB																					
0	MX3EN	Mixer 3 enable. 0 = disabled (default). 1 = enabled.																				

R23: Playback Mixer Left (Mixer 3) Control 1, 16,413 (0x401D)

Bit 7	Bit 6	Bit 5	Bit 4	Bit 3	Bit 2	Bit 1	Bit 0
		MX3G2[3:0]				MX3G1[3:0]	

Table 48. Playback Mixer Left (Mixer 3) Control 1 Register

Bits	Bit Name	Description																		
[7:4]	MX3G2[3:0]	Bypass gain control. The signal from the right channel record mixer (Mixer 2) bypasses the converters and gain can be applied before the left playback mixer (Mixer 3). <table border="1"> <thead> <tr> <th>Setting</th> <th>Gain</th> </tr> </thead> <tbody> <tr><td>0000</td><td>Mute (default)</td></tr> <tr><td>0001</td><td>-15 dB</td></tr> <tr><td>0010</td><td>-12 dB</td></tr> <tr><td>0011</td><td>-9 dB</td></tr> <tr><td>0100</td><td>-6 dB</td></tr> <tr><td>0101</td><td>-3 dB</td></tr> <tr><td>0110</td><td>0 dB</td></tr> <tr><td>0111</td><td>3 dB</td></tr> </tbody> </table>	Setting	Gain	0000	Mute (default)	0001	-15 dB	0010	-12 dB	0011	-9 dB	0100	-6 dB	0101	-3 dB	0110	0 dB	0111	3 dB
Setting	Gain																			
0000	Mute (default)																			
0001	-15 dB																			
0010	-12 dB																			
0011	-9 dB																			
0100	-6 dB																			
0101	-3 dB																			
0110	0 dB																			
0111	3 dB																			

CONTROL REGISTERS

Table 48. Playback Mixer Left (Mixer 3) Control 1 Register (Continued)

Bits	Bit Name	Description
		1000 6 dB
[3:0]	MX3G1[3:0]	Bypass gain control. The signal from the left channel record mixer (Mixer 1) bypasses the converters and gain can be applied before the left playback mixer (Mixer 3).
		Setting Gain
		0000 Mute (default)
		0001 -15 dB
		0010 -12 dB
		0011 -9 dB
		0100 -6 dB
		0101 -3 dB
		0110 0 dB
		0111 3 dB
		1000 6 dB

R24: Playback Mixer Right (Mixer 4) Control 0, 16,414 (0x401E)

Bit 7	Bit 6	Bit 5	Bit 4	Bit 3	Bit 2	Bit 1	Bit 0
Reserved	MX4RM	MX4LM			MX4AUXG[3:0]		MX4EN

Table 49. Playback Mixer Right (Mixer 4) Control 0 Register

Bits	Bit Name	Description
6	MX4RM	Mixer input mute. Mutes the right DAC input to the right channel playback mixer (Mixer 4). 0 = muted (default). 1 = unmuted.
5	MX4LM	Mixer input mute. Mutes the left DAC input to the right channel playback mixer (Mixer 4). 0 = muted (default). 1 = unmuted.
[4:1]	MX4AUXG[3:0]	Mixer input gain. Controls the right channel auxiliary input gain to the right channel playback mixer (Mixer 4).
		Setting Gain
		0000 Mute (default)
		0001 -15 dB
		0010 -12 dB
		0011 -9 dB
		0100 -6 dB
		0101 -3 dB
		0110 0 dB
		0111 3 dB
		1000 6 dB
0	MX4EN	Mixer 4 enable. 0 = disabled (default). 1 = enabled.

R25: Playback Mixer Right (Mixer 4) Control 1, 16,415 (0x401F)

Bit 7	Bit 6	Bit 5	Bit 4	Bit 3	Bit 2	Bit 1	Bit 0
		MX4G2[3:0]				MX4G1[3:0]	

CONTROL REGISTERS

Table 50. Playback Mixer Right (Mixer 4) Control 1 Register

Bits	Bit Name	Description	
[7:4]	MX4G2[3:0]	Bypass gain control. The signal from the right channel record mixer (Mixer 2) bypasses the converters and gain can be applied before the right playback mixer (Mixer 4).	
		Setting	Gain
		0000	Mute (default)
		0001	-15 dB
		0010	-12 dB
		0011	-9 dB
		0100	-6 dB
		0101	-3 dB
		0110	0 dB
		0111	3 dB
	1000	6 dB	
[3:0]	MX4G1[3:0]	Bypass gain control. The signal from the left channel record mixer (Mixer 1) bypasses the converters and gain can be applied before the right playback mixer (Mixer 4).	
		Setting	Gain
		0000	Mute (default)
		0001	-15 dB
		0010	-12 dB
		0011	-9 dB
		0100	-6 dB
		0101	-3 dB
		0110	0 dB
		0111	3 dB
	1000	6 dB	

R26: Playback L/R Mixer Left (Mixer 5) Line Output Control, 16,416 (0x4020)

Bit 7	Bit 6	Bit 5	Bit 4	Bit 3	Bit 2	Bit 1	Bit 0
	Reserved			MX5G4[1:0]		MX5G3[1:0]	MX5EN

Table 51. Playback L/R Mixer Left (Mixer 5) Line Output Control Register

Bits	Bit Name	Description	
[4:3]	MX5G4[1:0]	Mixer input gain boost. The signal from the right channel playback mixer (Mixer 4) can be enabled and boosted in the playback L/R mixer left (Mixer 5).	
		Setting	Gain Boost
		00	Mute (default)
		01	0 dB output (-6 dB gain on each of the two inputs)
		10	6 dB output (0 dB gain on each of the two inputs)
	11	Reserved	
[2:1]	MX5G3[1:0]	Mixer input gain boost. The signal from the left channel playback mixer (Mixer 3) can be enabled and boosted in the playback L/R mixer left (Mixer 5).	
		Setting	Gain Boost
		00	Mute (default)
		01	0 dB output (-6 dB gain on each of the two inputs)
		10	6 dB output (0 dB gain on each of the two inputs)
	11	Reserved	
0	MX5EN	Mixer 5 enable. 0 = disabled (default).	

CONTROL REGISTERS

Table 51. Playback L/R Mixer Left (Mixer 5) Line Output Control Register (Continued)

Bits	Bit Name	Description
		1 = enabled.

R27: Playback L/R Mixer Right (Mixer 6) Line Output Control, 16,417 (0x4021)

Bit 7	Bit 6	Bit 5	Bit 4	Bit 3	Bit 2	Bit 1	Bit 0
	Reserved			MX6G4[1:0]		MX6G3[1:0]	MX6EN

Table 52. Playback L/R Mixer Right (Mixer 6) Line Output Control Register

Bits	Bit Name	Description
[4:3]	MX6G4[1:0]	Mixer input gain boost. The signal from the right channel playback mixer (Mixer 4) can be enabled and boosted in the playback L/R mixer right (Mixer 6). Setting 00 Mute (default) 01 0 dB output (-6 dB gain on each of the two inputs) 10 6 dB output (0 dB gain on each of the two inputs) 11 Reserved
[2:1]	MX6G3[1:0]	Mixer input gain boost. The signal from the left channel playback mixer (Mixer 3) can be enabled and boosted in the playback L/R mixer right (Mixer 6). Setting 00 Mute (default) 01 0 dB output (-6 dB gain on each of the two inputs) 10 6 dB output (0 dB gain on each of the two inputs) 11 Reserved
0	MX6EN	Mixer 6 enable. 0 = disabled (default). 1 = enabled.

R28: Playback L/R Mixer Mono Output (Mixer 7) Control, 16,418 (0x4022)

Bit 7	Bit 6	Bit 5	Bit 4	Bit 3	Bit 2	Bit 1	Bit 0
		Reserved				MX7[1:0]	MX7EN

Table 53. Playback L/R Mixer Mono Output (Mixer 7) Control Register

Bits	Bit Name	Description
[2:1]	MX7[1:0]	L/R mono playback mixer (Mixer 7). Mixes the left and right playback mixers (Mixer 3 and Mixer 4) with either a 0 dB or 6 dB gain boost. Additionally, this mixer can operate as a common-mode output, which is used as the virtual ground in a capless headphone configuration. Setting 00 Common-mode output (default) 01 0 dB output (-6 dB gain on each of the two inputs) 10 6 dB output (0 dB gain on each of the two inputs) 11 Reserved
0	MX7EN	Mixer 7 enable. 0 = disabled (default). 1 = enabled.

CONTROL REGISTERS

R29: Playback Headphone Left Volume Control, 16,419 (0x4023)

Bit 7	Bit 6	Bit 5	Bit 4	Bit 3	Bit 2	Bit 1	Bit 0
LHPVOL[5:0]						LHPM	HPEN

Table 54. Playback Headphone Left Volume Control Register

Bits	Bit Name	Description												
[7:2]	LHPVOL[5:0]	Headphone volume control for left channel, LHP output. Each 1-bit step corresponds to a 1 dB increase in volume. See Table 72 for a complete list of the volume settings.												
		<table border="1"> <thead> <tr> <th>Setting</th> <th>Volume</th> </tr> </thead> <tbody> <tr> <td>000000</td> <td>-57 dB (default)</td> </tr> <tr> <td>...</td> <td>...</td> </tr> <tr> <td>111001</td> <td>0 dB</td> </tr> <tr> <td>...</td> <td>...</td> </tr> <tr> <td>111111</td> <td>6 dB</td> </tr> </tbody> </table>	Setting	Volume	000000	-57 dB (default)	111001	0 dB	111111	6 dB
Setting	Volume													
000000	-57 dB (default)													
...	...													
111001	0 dB													
...	...													
111111	6 dB													
1	LHPM	Headphone mute for left channel, LHP output (active low). 0 = mute. 1 = unmute (default).												
0	HPEN	Headphone volume control enable. Logical OR with the HPMODE bit in Register R30. If either the HPEN bit or the HPMODE bit is set to 1, the headphone output is enabled. 0 = disabled (default). 1 = enabled.												

R30: Playback Headphone Right Volume Control, 16,420 (0x4024)

Bit 7	Bit 6	Bit 5	Bit 4	Bit 3	Bit 2	Bit 1	Bit 0
RHPVOL[5:0]						RHPM	HPMODE

Table 55. Playback Headphone Right Volume Control Register

Bits	Bit Name	Description												
[7:2]	RHPVOL[5:0]	Headphone volume control for right channel, RHP output. Each 1-bit step corresponds to a 1 dB increase in volume. See Table 72 for a complete list of the volume settings.												
		<table border="1"> <thead> <tr> <th>Setting</th> <th>Volume</th> </tr> </thead> <tbody> <tr> <td>000000</td> <td>-57 dB (default)</td> </tr> <tr> <td>...</td> <td>...</td> </tr> <tr> <td>111001</td> <td>0 dB</td> </tr> <tr> <td>...</td> <td>...</td> </tr> <tr> <td>111111</td> <td>6 dB</td> </tr> </tbody> </table>	Setting	Volume	000000	-57 dB (default)	111001	0 dB	111111	6 dB
Setting	Volume													
000000	-57 dB (default)													
...	...													
111001	0 dB													
...	...													
111111	6 dB													
1	RHPM	Headphone mute for right channel, RHP output (active low). 0 = mute. 1 = unmute (default).												
0	HPMODE	RHP and LHP output mode. These pins can be configured for either line outputs or headphone outputs. Logical OR with the HPEN bit in Register R29. If either the HPMODE bit or the HPEN bit is set to 1, the headphone output is enabled. 0 = enable line output (default). 1 = enable headphone output.												

R31: Playback Line Output Left Volume Control, 16,421 (0x4025)

Bit 7	Bit 6	Bit 5	Bit 4	Bit 3	Bit 2	Bit 1	Bit 0
LOUTVOL[5:0]						LOUTM	LOMODE

CONTROL REGISTERS

Table 56. Playback Line Output Left Volume Control Register

Bits	Bit Name	Description												
[7:2]	LOUTVOL[5:0]	Line output volume control for left channel, LOU _{TN} and LOU _{TP} outputs. Each 1-bit step corresponds to a 1 dB increase in volume. See Table 72 for a complete list of the volume settings.												
		<table border="1"> <thead> <tr> <th>Setting</th> <th>Volume</th> </tr> </thead> <tbody> <tr> <td>000000</td> <td>-57 dB (default)</td> </tr> <tr> <td>...</td> <td>...</td> </tr> <tr> <td>111001</td> <td>0 dB</td> </tr> <tr> <td>...</td> <td>...</td> </tr> <tr> <td>111111</td> <td>6 dB</td> </tr> </tbody> </table>	Setting	Volume	000000	-57 dB (default)	111001	0 dB	111111	6 dB
Setting	Volume													
000000	-57 dB (default)													
...	...													
111001	0 dB													
...	...													
111111	6 dB													
1	LOUTM	Line output mute for left channel, LOU _{TN} and LOU _{TP} outputs (active low). 0 = mute. 1 = unmute (default).												
0	LOMODE	Line output mode for left channel, LOU _{TN} and LOU _{TP} outputs. These pins can be configured for either line outputs or headphone outputs. To drive earpiece speakers, set this bit to 1 (headphone output). 0 = line output (default). 1 = headphone output.												

R32: Playback Line Output Right Volume Control, 16,422 (0x4026)

Bit 7	Bit 6	Bit 5	Bit 4	Bit 3	Bit 2	Bit 1	Bit 0
ROUTVOL[5:0]						ROUTM	ROMODE

Table 57. Playback Line Output Right Volume Control Register

Bits	Bit Name	Description												
[7:2]	ROUTVOL[5:0]	Line output volume control for right channel, ROU _{TN} and ROU _{TP} outputs. Each 1-bit step corresponds to a 1 dB increase in volume. See Table 72 for a complete list of the volume settings.												
		<table border="1"> <thead> <tr> <th>Setting</th> <th>Volume</th> </tr> </thead> <tbody> <tr> <td>000000</td> <td>-57 dB (default)</td> </tr> <tr> <td>...</td> <td>...</td> </tr> <tr> <td>111001</td> <td>0 dB</td> </tr> <tr> <td>...</td> <td>...</td> </tr> <tr> <td>111111</td> <td>6 dB</td> </tr> </tbody> </table>	Setting	Volume	000000	-57 dB (default)	111001	0 dB	111111	6 dB
Setting	Volume													
000000	-57 dB (default)													
...	...													
111001	0 dB													
...	...													
111111	6 dB													
1	ROUTM	Line output mute for right channel, ROU _{TN} and ROU _{TP} outputs (active low). 0 = mute. 1 = unmute (default).												
0	ROMODE	Line output mode for right channel, ROU _{TN} and ROU _{TP} outputs. These pins can be configured for either line outputs or headphone outputs. To drive earpiece speakers, set this bit to 1 (headphone output). 0 = line output (default). 1 = headphone output.												

R33: Playback Mono Output Control, 16,423 (0x4027)

Bit 7	Bit 6	Bit 5	Bit 4	Bit 3	Bit 2	Bit 1	Bit 0
MONOVOL[5:0]						MONOM	MOMODE

Table 58. Playback Mono Output Control Register

Bits	Bit Name	Description
[7:2]	MONOVOL[5:0]	Mono output volume control. Each 1-bit step corresponds to a 1 dB increase in volume. If MX7[1:0] in Register R28 is set for common-mode output, volume control is disabled. See Table 72 for a complete list of the volume settings.

CONTROL REGISTERS

Table 58. Playback Mono Output Control Register (Continued)

Bits	Bit Name	Description												
		<table border="1"> <thead> <tr> <th>Setting</th> <th>Volume</th> </tr> </thead> <tbody> <tr> <td>000000</td> <td>-57 dB (default)</td> </tr> <tr> <td>...</td> <td>...</td> </tr> <tr> <td>111001</td> <td>0 dB</td> </tr> <tr> <td>...</td> <td>...</td> </tr> <tr> <td>111111</td> <td>6 dB</td> </tr> </tbody> </table>	Setting	Volume	000000	-57 dB (default)	111001	0 dB	111111	6 dB
Setting	Volume													
000000	-57 dB (default)													
...	...													
111001	0 dB													
...	...													
111111	6 dB													
1	MONOM	Mono output mute (active low). 0 = mute. 1 = unmute (default).												
0	MOMODE	Headphone mode enable. If MX7[1:0] in Register R28 is set for common-mode output for a capless headphone configuration, this bit should be set to 1 (headphone output). 0 = line output (default). 1 = headphone output.												

R34: Playback Pop/Click Suppression, 16,424 (0x4028)

Bit 7	Bit 6	Bit 5	Bit 4	Bit 3	Bit 2	Bit 1	Bit 0
	Reserved		POPMODE	POPLESS		ASLEW[1:0]	Reserved

Table 59. Playback Pop/Click Suppression Register

Bits	Bit Name	Description										
4	POPMODE	Pop suppression circuit power saving mode. The pop suppression circuits charge faster in normal operation; however, after they are charged, they can be put into low power operation. 0 = normal (default). 1 = low power.										
3	POPLESS	Pop suppression disable. The pop suppression circuits are enabled by default. They can be disabled to save power; however, disabling the circuits increases the risk of pops and clicks. 0 = enabled (default). 1 = disabled.										
[2:1]	ASLEW[1:0]	Analog volume slew rate for playback volume controls. <table border="1"> <thead> <tr> <th>Setting</th> <th>Slew Rate</th> </tr> </thead> <tbody> <tr> <td>00</td> <td>21.25 ms (default)</td> </tr> <tr> <td>01</td> <td>42.5 ms</td> </tr> <tr> <td>10</td> <td>85 ms</td> </tr> <tr> <td>11</td> <td>Off</td> </tr> </tbody> </table>	Setting	Slew Rate	00	21.25 ms (default)	01	42.5 ms	10	85 ms	11	Off
Setting	Slew Rate											
00	21.25 ms (default)											
01	42.5 ms											
10	85 ms											
11	Off											

R35: Playback Power Management, 16,425 (0x4029)

Bit 7	Bit 6	Bit 5	Bit 4	Bit 3	Bit 2	Bit 1	Bit 0
			Reserved			PREN	PLEN

Table 60. Playback Power Management Register

Bits	Bit Name	Description
1	PREN	Playback right channel enable. 0 = disabled (default). 1 = enabled.
0	PLEN	Playback left channel enable. 0 = disabled (default).

CONTROL REGISTERS

Table 60. Playback Power Management Register (Continued)

Bits	Bit Name	Description
		1 = enabled.

R36: DAC Control 0, 16,426 (0x402A)

Bit 7	Bit 6	Bit 5	Bit 4	Bit 3	Bit 2	Bit 1	Bit 0
	DACMONO[1:0]	DACPOL		Reserved	DEMPH		DACEN[1:0]

Table 61. DAC Control 0 Register

Bits	Bit Name	Description										
[7:6]	DACMONO[1:0]	DAC mono mode. The DAC channels can be set to mono mode within the DAC and output on the left channel, the right channel, or both channels. <table border="1"> <thead> <tr> <th>Setting</th> <th>Mono Mode</th> </tr> </thead> <tbody> <tr> <td>00</td> <td>Stereo (default)</td> </tr> <tr> <td>01</td> <td>Left channel in mono mode</td> </tr> <tr> <td>10</td> <td>Right channel in mono mode</td> </tr> <tr> <td>11</td> <td>Both channels in mono mode</td> </tr> </tbody> </table>	Setting	Mono Mode	00	Stereo (default)	01	Left channel in mono mode	10	Right channel in mono mode	11	Both channels in mono mode
Setting	Mono Mode											
00	Stereo (default)											
01	Left channel in mono mode											
10	Right channel in mono mode											
11	Both channels in mono mode											
5	DACPOL	Invert input polarity of the DACs. 0 = normal (default). 1 = inverted.										
2	DEMPH	DAC de-emphasis filter enable. The de-emphasis filter is designed for use with a sampling rate of 44.1 kHz only. 0 = disabled (default). 1 = enabled.										
[1:0]	DACEN[1:0]	DAC enable. <table border="1"> <thead> <tr> <th>Setting</th> <th>DACs Enabled</th> </tr> </thead> <tbody> <tr> <td>00</td> <td>Both off (default)</td> </tr> <tr> <td>01</td> <td>Left on</td> </tr> <tr> <td>10</td> <td>Right on</td> </tr> <tr> <td>11</td> <td>Both on</td> </tr> </tbody> </table>	Setting	DACs Enabled	00	Both off (default)	01	Left on	10	Right on	11	Both on
Setting	DACs Enabled											
00	Both off (default)											
01	Left on											
10	Right on											
11	Both on											

R37: DAC Control 1, 16,427 (0x402B)

Bit 7	Bit 6	Bit 5	Bit 4	Bit 3	Bit 2	Bit 1	Bit 0
							LDAVOL[7:0]

Table 62. DAC Control 1 Register

Bits	Bit Name	Description														
[7:0]	LDAVOL[7:0]	Controls the digital volume attenuation for left channel inputs from the left DAC. Each bit corresponds to a 0.375 dB step with slewing between settings. See Table 71 for a complete list of the volume settings. <table border="1"> <thead> <tr> <th>Setting</th> <th>Volume Attenuation</th> </tr> </thead> <tbody> <tr> <td>00000000</td> <td>0 dB (default)</td> </tr> <tr> <td>00000001</td> <td>-0.375 dB</td> </tr> <tr> <td>00000010</td> <td>-0.75 dB</td> </tr> <tr> <td>...</td> <td>...</td> </tr> <tr> <td>11111110</td> <td>-95.25 dB</td> </tr> <tr> <td>11111111</td> <td>-95.625 dB</td> </tr> </tbody> </table>	Setting	Volume Attenuation	00000000	0 dB (default)	00000001	-0.375 dB	00000010	-0.75 dB	11111110	-95.25 dB	11111111	-95.625 dB
Setting	Volume Attenuation															
00000000	0 dB (default)															
00000001	-0.375 dB															
00000010	-0.75 dB															
...	...															
11111110	-95.25 dB															
11111111	-95.625 dB															

CONTROL REGISTERS

R38: DAC Control 2, 16,428 (0x402C)

Bit 7	Bit 6	Bit 5	Bit 4	Bit 3	Bit 2	Bit 1	Bit 0
RDAVOL[7:0]							

Table 63. DAC Control 2 Register

Bits	Bit Name	Description														
[7:0]	RDAVOL[7:0]	Controls the digital volume attenuation for right channel inputs from the right DAC. Each bit corresponds to a 0.375 dB step with slewing between settings. See Table 71 for a complete list of the volume settings.														
		<table border="1"> <thead> <tr> <th>Setting</th> <th>Volume Attenuation</th> </tr> </thead> <tbody> <tr> <td>00000000</td> <td>0 dB (default)</td> </tr> <tr> <td>00000001</td> <td>-0.375 dB</td> </tr> <tr> <td>00000010</td> <td>-0.75 dB</td> </tr> <tr> <td>...</td> <td>...</td> </tr> <tr> <td>11111110</td> <td>-95.25 dB</td> </tr> <tr> <td>11111111</td> <td>-95.625 dB</td> </tr> </tbody> </table>	Setting	Volume Attenuation	00000000	0 dB (default)	00000001	-0.375 dB	00000010	-0.75 dB	11111110	-95.25 dB	11111111	-95.625 dB
Setting	Volume Attenuation															
00000000	0 dB (default)															
00000001	-0.375 dB															
00000010	-0.75 dB															
...	...															
11111110	-95.25 dB															
11111111	-95.625 dB															

R39: Serial Port Pad Control, 16,429 (0x402D)

The optional pull-up/pull-down resistors are nominally 250 kΩ. When enabled, these pull-up/pull-down resistors set the serial port signals to a defined state when the signal source becomes three-state.

Bit 7	Bit 6	Bit 5	Bit 4	Bit 3	Bit 2	Bit 1	Bit 0
	ADCSDP[1:0]		DACSDP[1:0]		LRCLKP[1:0]		BCLKP[1:0]

Table 64. Serial Port Pad Control Register

Bits	Bit Name	Description										
[7:6]	ADCSDP[1:0]	ADC_SDATA pad pull-up/pull-down configuration.										
		<table border="1"> <thead> <tr> <th>Setting</th> <th>Configuration</th> </tr> </thead> <tbody> <tr> <td>00</td> <td>Pull-up</td> </tr> <tr> <td>01</td> <td>Reserved</td> </tr> <tr> <td>10</td> <td>None (default)</td> </tr> <tr> <td>11</td> <td>Pull-down</td> </tr> </tbody> </table>	Setting	Configuration	00	Pull-up	01	Reserved	10	None (default)	11	Pull-down
Setting	Configuration											
00	Pull-up											
01	Reserved											
10	None (default)											
11	Pull-down											
[5:4]	DACSDP[1:0]	DAC_SDATA pad pull-up/pull-down configuration.										
		<table border="1"> <thead> <tr> <th>Setting</th> <th>Configuration</th> </tr> </thead> <tbody> <tr> <td>00</td> <td>Pull-up</td> </tr> <tr> <td>01</td> <td>Reserved</td> </tr> <tr> <td>10</td> <td>None (default)</td> </tr> <tr> <td>11</td> <td>Pull-down</td> </tr> </tbody> </table>	Setting	Configuration	00	Pull-up	01	Reserved	10	None (default)	11	Pull-down
Setting	Configuration											
00	Pull-up											
01	Reserved											
10	None (default)											
11	Pull-down											
[3:2]	LRCLKP[1:0]	LRCLK pad pull-up/pull-down configuration.										
		<table border="1"> <thead> <tr> <th>Setting</th> <th>Configuration</th> </tr> </thead> <tbody> <tr> <td>00</td> <td>Pull-up</td> </tr> <tr> <td>01</td> <td>Reserved</td> </tr> <tr> <td>10</td> <td>None (default)</td> </tr> <tr> <td>11</td> <td>Pull-down</td> </tr> </tbody> </table>	Setting	Configuration	00	Pull-up	01	Reserved	10	None (default)	11	Pull-down
Setting	Configuration											
00	Pull-up											
01	Reserved											
10	None (default)											
11	Pull-down											
[1:0]	BCLKP[1:0]	BCLK pad pull-up/pull-down configuration.										
		<table border="1"> <thead> <tr> <th>Setting</th> <th>Configuration</th> </tr> </thead> <tbody> <tr> <td>00</td> <td>Pull-up</td> </tr> <tr> <td>01</td> <td>Reserved</td> </tr> <tr> <td>10</td> <td>None (default)</td> </tr> </tbody> </table>	Setting	Configuration	00	Pull-up	01	Reserved	10	None (default)		
Setting	Configuration											
00	Pull-up											
01	Reserved											
10	None (default)											

CONTROL REGISTERS

Table 64. Serial Port Pad Control Register (Continued)

Bits	Bit Name	Description
		11 Pull-down

R40: Control Port Pad Control 0, 16,431 (0x402F)

The optional pull-up/pull-down resistors are nominally 250 k Ω . When enabled, these pull-up/pull-down resistors set the control port signals to a defined state when the signal source becomes three-state.

Bit 7	Bit 6	Bit 5	Bit 4	Bit 3	Bit 2	Bit 1	Bit 0
	CDATP[1:0]		CLCHP[1:0]		SCLP[1:0]		SDAP[1:0]

Table 65. Control Port Pad Control 0 Register

Bits	Bit Name	Description
[7:6]	CDATP[1:0]	CDATA pad pull-up/pull-down configuration. Setting Configuration 00 Pull-up 01 Reserved 10 None (default) 11 Pull-down
[5:4]	CLCHP[1:0]	CLATCH pad pull-up/pull-down configuration. Setting Configuration 00 Pull-up 01 Reserved 10 None (default) 11 Pull-down
[3:2]	SCLP[1:0]	SCL/CCLK pad pull-up/pull-down configuration. Setting Configuration 00 Pull-up 01 Reserved 10 None (default) 11 Pull-down
[1:0]	SDAP[1:0]	SDA/COUT pad pull-up/pull-down configuration. Setting Configuration 00 Pull-up 01 Reserved 10 None (default) 11 Pull-down

R41: Control Port Pad Control 1, 16,432 (0x4030)

With IOVDD set to 3.3 V, the low and high drive strengths of the SDA/COUT pin are approximately 2.0 mA and 4.0 mA, respectively. The high drive strength mode may be useful for generating a stronger ACK pulse in I²C mode, if needed.

Bit 7	Bit 6	Bit 5	Bit 4	Bit 3	Bit 2	Bit 1	Bit 0
			Reserved				SDASTR

Table 66. Control Port Pad Control 1 Register

Bits	Bit Name	Description
0	SDASTR	SDA/COUT pin drive strength.

CONTROL REGISTERS

Table 66. Control Port Pad Control 1 Register (Continued)

Bits	Bit Name	Description
		0 = low (default). 1 = high.

R42: Jack Detect Pin Control, 16,433 (0x4031)

With IOVDD set to 3.3 V, the low and high drive strengths of the JACKDET/MICIN pin are approximately 2.0 mA and 4.0 mA, respectively. The optional pull-up/pull-down resistors are nominally 250 k Ω . When enabled, these pull-up/pull-down resistors set the input signals to a defined state when the signal source becomes three-state.

Bit 7	Bit 6	Bit 5	Bit 4	Bit 3	Bit 2	Bit 1	Bit 0
	Reserved	JDSTR	Reserved		JDP[1:0]		Reserved

Table 67. Jack Detect Pin Control Register

Bits	Bit Name	Description	
5	JDSTR	JACKDET/MICIN pin drive strength. 0 = low (default). 1 = high.	
[3:2]	JDP[1:0]	JACKDET/MICIN pad pull-up/pull-down configuration.	
		Setting	
		Configuration	
		00	Pull-up
		01	Reserved
		10	None (default)
		11	Pull-down

R67: Dejitter Control, 16,438 (0x4036)

The dejitter control register allows the size of the dejitter window to be set, and also allows all dejitter circuits in the device to be activated or bypassed. Dejitter circuits protect against duplicate samples or skipped samples due to jitter from the serial ports in subordinate mode. Disabling and reenabling certain subsystems in the device—that is, the ADCs, serial ports, and DACs—during operation can cause the associated dejitter circuits to fail. As a result, audio data fails to be output to the next subsystem in the device.

When the serial ports are in main mode, the dejitter circuit can be bypassed by setting the dejitter window to 0. When the serial ports are in subordinate mode, the dejitter circuit can be reinitialized prior to outputting audio from the device, guaranteeing that audio is output to the next subsystem in the device. Any time that audio must pass through the ADCs, serial port, or DACs, the dejitter circuit can be bypassed and reset by setting the dejitter window size to 0. In this way, the dejitter circuit can be immediately reactivated, without a wait period, by setting the dejitter window size to the default value of 3.

Bit 7	Bit 6	Bit 5	Bit 4	Bit 3	Bit 2	Bit 1	Bit 0
							DEJIT[7:0]

Table 68. Dejitter Control Register

Bits	Bit Name	Description	
[7:0]	DEJIT[7:0]	Dejitter window size.	
		Window Size	
		Core Clock Cycles	
		00000000	0
	
		00000011	3 (default)
	
		00000101	5

CONTROL REGISTERS

Table 69. R8 and R9 Volume Settings

Binary Value	Volume Setting (dB)
000000	-12
000001	-11.25
000010	-10.5
000011	-9.75
000100	-9
000101	-8.25
000110	-7.5
000111	-6.75
001000	-6
001001	-5.25
001010	-4.5
001011	-3.75
001100	-3
001101	-2.25
001110	-1.5
001111	-0.75
010000	0
010001	0.75
010010	1.5
010011	2.25
010100	3
010101	3.75
010110	4.5
010111	5.25
011000	6
011001	6.75
011010	7.5
011011	8.25
011100	9
011101	9.75
011110	10.5
011111	11.25
100000	12
100001	12.75
100010	13.5
100011	14.25
100100	15
100101	15.75
100110	16.5
100111	17.25
101000	18
101001	18.75
101010	19.5
101011	20.25
101100	21
101101	21.75
101110	22.5
101111	23.25
110000	24

Table 69. R8 and R9 Volume Settings (Continued)

Binary Value	Volume Setting (dB)
110001	24.75
110010	25.5
110011	26.25
110100	27
110101	27.75
110110	28.5
110111	29.25
111000	30
111001	30.75
111010	31.5
111011	32.25
111100	33
111101	33.75
111110	34.5
111111	35.25

Table 70. R14 Noise Gate Threshold

Binary Value	Noise Gate Threshold (dB)
000000	-76.5
000001	-75
000010	-73.5
000011	-72
000100	-70.5
000101	-69
000110	-67.5
000111	-66
010000	-64.5
010001	-63
010010	-61.5
010011	-60
010100	-58.5
010101	-57
010110	-55.5
010111	-54
100000	-52.5
100001	-51
100010	-49.5
100011	-48
100100	-46.5
100101	-45
100110	-43.5
100111	-42
110000	-40.5
110001	-39
110010	-37.5
110011	-36
110100	-34.5
110101	-33
110110	-31.5

CONTROL REGISTERS

Table 70. R14 Noise Gate Threshold (Continued)

Binary Value	Noise Gate Threshold (dB)
11111	-30

Table 71. R20, R21, R37, and R38 Volume Settings

Binary Value	Volume Attenuation (dB)
00000000	0
00000001	-0.375
00000010	-0.75
00000011	-1.125
00000100	-1.5
00000101	-1.875
00000110	-2.25
00000111	-2.625
00001000	-3
00001001	-3.375
00001010	-3.75
00001011	-4.125
00001100	-4.5
00001101	-4.875
00001110	-5.25
00001111	-5.625
00010000	-6
00010001	-6.375
00010010	-6.75
00010011	-7.125
00010100	-7.5
00010101	-7.875
00010110	-8.25
00010111	-8.625
00011000	-9
00011001	-9.375
00011010	-9.75
00011011	-10.125
00011100	-10.5
00011101	-10.875
00011110	-11.25
00011111	-11.625
00100000	-12
00100001	-12.375
00100010	-12.75
00100011	-13.125
00100100	-13.5
00100101	-13.875
00100110	-14.25
00100111	-14.625
00101000	-15
00101001	-15.375
00101010	-15.75
00101011	-16.125
00101100	-16.5

Table 71. R20, R21, R37, and R38 Volume Settings (Continued)

Binary Value	Volume Attenuation (dB)
00101101	-16.875
00101110	-17.25
00101111	-17.625
00110000	-18
00110001	-18.375
00110010	-18.75
00110011	-19.125
00110100	-19.5
00110101	-19.875
00110110	-20.25
00110111	-20.625
00111000	-21
00111001	-21.375
00111010	-21.75
00111011	-22.125
00111100	-22.5
00111101	-22.875
00111110	-23.25
00111111	-23.625
01000000	-24
01000001	-24.375
01000010	-24.75
01000011	-25.125
01000100	-25.5
01000101	-25.875
01000110	-26.25
01000111	-26.625
01001000	-27
01001001	-27.375
01001010	-27.75
01001011	-28.125
01001100	-28.5
01001101	-28.875
01001110	-29.25
01001111	-29.625
01010000	-30
01010001	-30.375
01010010	-30.75
01010011	-31.125
01010100	-31.5
01010101	-31.875
01010110	-32.25
01010111	-32.625
01011000	-33
01011001	-33.375
01011010	-33.75
01011011	-34.125
01011100	-34.5
01011101	-34.875

CONTROL REGISTERS

Table 71. R20, R21, R37, and R38 Volume Settings (Continued)

Binary Value	Volume Attenuation (dB)
01011110	-35.25
01011111	-35.625
01100000	-36
01100001	-36.375
01100010	-36.75
01100011	-37.125
01100100	-37.5
01100101	-37.875
01100110	-38.25
01100111	-38.625
01101000	-39
01101001	-39.375
01101010	-39.75
01101011	-40.125
01101100	-40.5
01101101	-40.875
01101110	-41.25
01101111	-41.625
01110000	-42
01110001	-42.375
01110010	-42.75
01110011	-43.125
01110100	-43.5
01110101	-43.875
01110110	-44.25
01110111	-44.625
01111000	-45
01111001	-45.375
01111010	-45.75
01111011	-46.125
01111100	-46.5
01111101	-46.875
01111110	-47.25
01111111	-47.625
10000000	-48
10000001	-48.375
10000010	-48.75
10000011	-49.125
10000100	-49.5
10000101	-49.875
10000110	-50.25
10000111	-50.625
10001000	-51
10001001	-51.375
10001010	-51.75
10001011	-52.125
10001100	-52.5
10001101	-52.875
10001110	-53.25

Table 71. R20, R21, R37, and R38 Volume Settings (Continued)

Binary Value	Volume Attenuation (dB)
10001111	-53.625
10010000	-54
10010001	-54.375
10010010	-54.75
10010011	-55.125
10010100	-55.5
10010101	-55.875
10010110	-56.25
10010111	-56.625
10011000	-57
10011001	-57.375
10011010	-57.75
10011011	-58.125
10011100	-58.5
10011101	-58.875
10011110	-59.25
10011111	-59.625
10100000	-60
10100001	-60.375
10100010	-60.75
10100011	-61.125
10100100	-61.5
10100101	-61.875
10100110	-62.25
10100111	-62.625
10101000	-63
10101001	-63.375
10101010	-63.75
10101011	-64.125
10101100	-64.5
10101101	-64.875
10101110	-65.25
10101111	-65.625
10110000	-66
10110001	-66.375
10110010	-66.75
10110011	-67.125
10110100	-67.5
10110101	-67.875
10110110	-68.25
10110111	-68.625
10111000	-69
10111001	-69.375
10111010	-69.75
10111011	-70.125
10111100	-70.5
10111101	-70.875
10111110	-71.25
10111111	-71.625

CONTROL REGISTERS

Table 71. R20, R21, R37, and R38 Volume Settings (Continued)

Binary Value	Volume Attenuation (dB)
11000000	-72
11000001	-72.375
11000010	-72.75
11000011	-73.125
11000100	-73.5
11000101	-73.875
11000110	-74.25
11000111	-74.625
11001000	-75
11001001	-75.375
11001010	-75.75
11001011	-76.125
11001100	-76.5
11001101	-76.875
11001110	-77.25
11001111	-77.625
11010000	-78
11010001	-78.375
11010010	-78.75
11010011	-79.125
11010100	-79.5
11010101	-79.875
11010110	-80.25
11010111	-80.625
11011000	-81
11011001	-81.375
11011010	-81.75
11011011	-82.125
11011100	-82.5
11011101	-82.875
11011110	-83.25
11011111	-83.625
11100000	-84
11100001	-84.375
11100010	-84.75
11100011	-85.125
11100100	-85.5
11100101	-85.875
11100110	-86.25
11100111	-86.625
11101000	-87
11101001	-87.375
11101010	-87.75
11101011	-88.125
11101100	-88.5
11101101	-88.875
11101110	-89.25
11101111	-89.625
11110000	-90

Table 71. R20, R21, R37, and R38 Volume Settings (Continued)

Binary Value	Volume Attenuation (dB)
11110001	-90.375
11110010	-90.75
11110011	-91.125
11110100	-91.5
11110101	-91.875
11110110	-92.25
11110111	-92.625
11111000	-93
11111001	-93.375
11111010	-93.75
11111011	-94.125
11111100	-94.5
11111101	-94.875
11111110	-95.25
11111111	-95.625

Table 72. R29 through R33 Volume Settings

Binary Value	Volume Setting (dB)
000000	-57
000001	-56
000010	-55
000011	-54
000100	-53
000101	-52
000110	-51
000111	-50
001000	-49
001001	-48
001010	-47
001011	-46
001100	-45
001101	-44
001110	-43
001111	-42
010000	-41
010001	-40
010010	-39
010011	-38
010100	-37
010101	-36
010110	-35
010111	-34
011000	-33
011001	-32
011010	-31
011011	-30
011100	-29
011101	-28
011110	-27

CONTROL REGISTERS**Table 72. R29 through R33 Volume Settings (Continued)**

Binary Value	Volume Setting (dB)
011111	-26
100000	-25
100001	-24
100010	-23
100011	-22
100100	-21
100101	-20
100110	-19
100111	-18
101000	-17
101001	-16
101010	-15
101011	-14
101100	-13
101101	-12
101110	-11
101111	-10
110000	-9
110001	-8
110010	-7
110011	-6
110100	-5
110101	-4
110110	-3
110111	-2
111000	-1
111001	0
111010	1
111011	2
111100	3
111101	4
111110	5
111111	6

OUTLINE DIMENSIONS

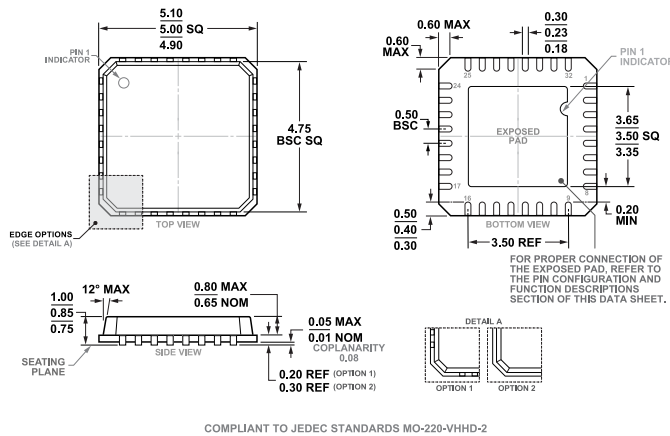

**Figure 66. 32-Lead Lead Frame Chip Scale Package [LFCSP]
5 mm × 5 mm Body and 0.85 mm Package Height
(CP-32-4)
Dimensions shown in millimeters**

ORDERING GUIDE

Model ^{1,2}	Temperature Range	Package Description	Packing Quantity	Package Option
ADAU1961WBCPZ	-40°C to +105°C	32-Lead Lead Frame Chip Scale Package [LFCSP]	Tray, 490	CP-32-4
ADAU1961WBCPZ-R7	-40°C to +105°C	32-Lead Lead Frame Chip Scale Package [LFCSP]	Reel, 1500	CP-32-4
ADAU1961WBCPZ-RL	-40°C to +105°C	32-Lead Lead Frame Chip Scale Package [LFCSP]	Reel, 5000	CP-32-4

¹ Z = RoHS Compliant Part.

² W = Qualified for Automotive Applications.

AUTOMOTIVE PRODUCTS

The ADAU1961W models are available with controlled manufacturing to support the quality and reliability requirements of automotive applications. Note that these automotive models may have specifications that differ from the commercial models; therefore, designers should review the [Specifications](#) section of this data sheet carefully. Only the automotive grade products shown are available for use in automotive applications. Contact your local Analog Devices account representative for specific product ordering information and to obtain the specific Automotive Reliability reports for these models.

Looking for pricing, stock, or lifecycle information?

Click below to explore more details on WIN SOURCE:

 [View ADAU1961WBCPZ-R7 on WIN SOURCE](#)

 [Analog Devices Inc. Information](#)

Optimize Your Supply Chain with WIN SOURCE Solutions

-  Global Sourcing Solution
-  Obsolete Management
-  Cost Control Management
-  Shortage Management
-  Alternative Solution
-  Excess Inventory Management