



**THE DATASHEET OF
ACZ16NBR1E-15FD1-24C**



SERIES: ACZ16 | **DESCRIPTION:** MECHANICAL INCREMENTAL ENCODER

ELECTRICAL SPECIFICATIONS

parameter	conditions/description	min	typ	max	units
output waveform	square wave				
output signals	A, B phase				
current consumption	0.5 mA				
output phase difference	T1, T2, T3, T4 ≥ 3.5 ms @ 60 rpm (see output waveform)				
supply voltage	5 V dc max.				
output resolution	12, 24 ppr				
insulation resistance	50 V dc, 100 MΩ				
withstand voltage	50 V ac				

MECHANICAL SPECIFICATIONS

parameter	conditions/description	min	typ	max	units
shaft load	axial			7	kgf
rotational torque	with detent click	50		130	gf·cm
	without detent click	90		210	gf·cm
rotational life				100,000	cycles

ENVIRONMENTAL SPECIFICATIONS

parameter	conditions/description	min	typ	max	units
operating temperature		-10		65	°C
storage temperature		-40		75	°C
humidity		85			% RH
vibration	0.75 mm max. travel for 2 hours	10		55	Hz

- Notes:
1. It is recommended to use products within 6 months.
 2. For storage conditions, it is recommended to keep away from direct sunlight, corrosive gas, or high humidity conditions.
 3. Use the product as soon as possible once the plastic bag has been unsealed, and reseal the bag if product is not immediately used.
 4. The products are packaged in sealed bags with anti humidity tablets.

PART NUMBER KEY

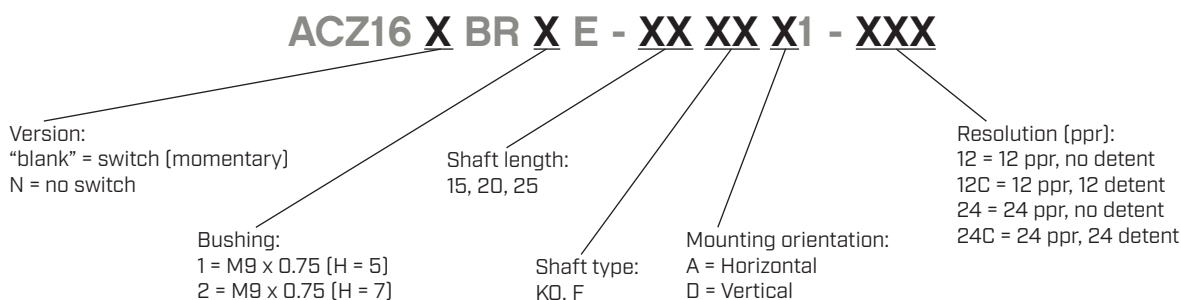

SHAFT OPTIONS

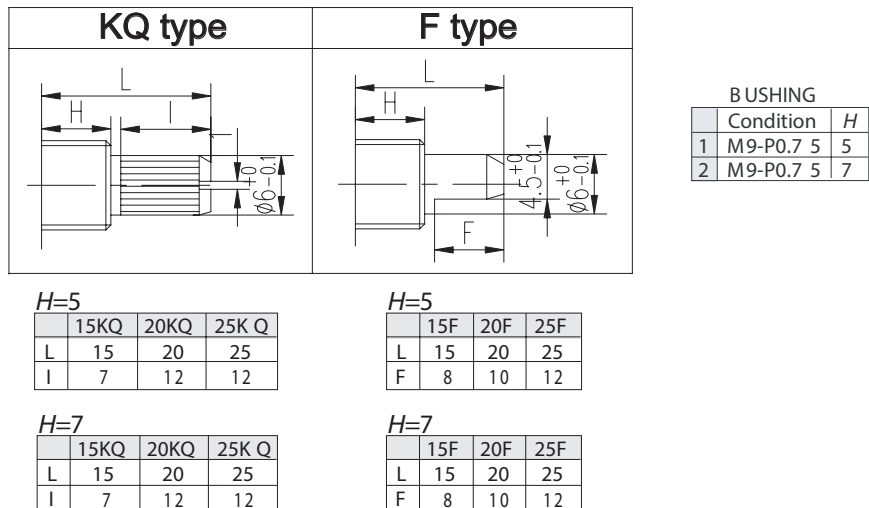

OUTPUT WAVEFORM

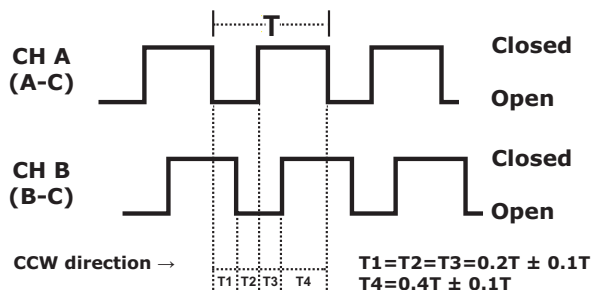

DETENT POSITIONS

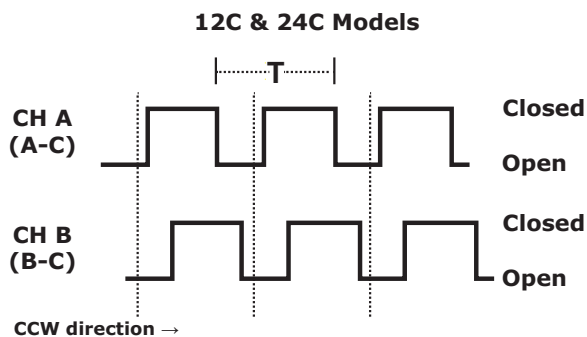

SLIDING NOISE

$t =$ Masking time to avoid chatter (5mS) $V_1 = V_2 = 1V$ max.

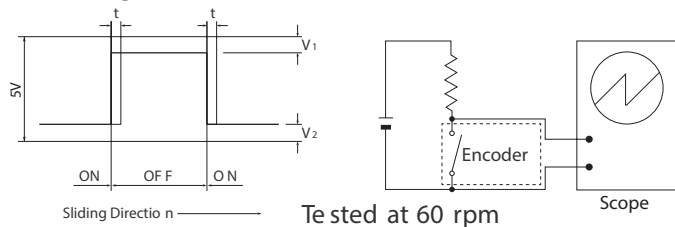

SUGGESTED FILTER

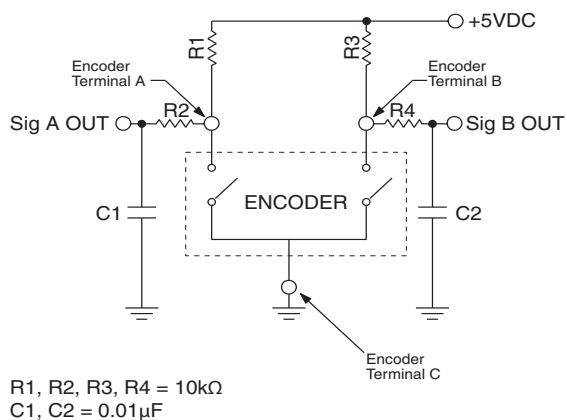

MECHANICAL DRAWING (HORIZONTAL)

ACZ16NBRXE

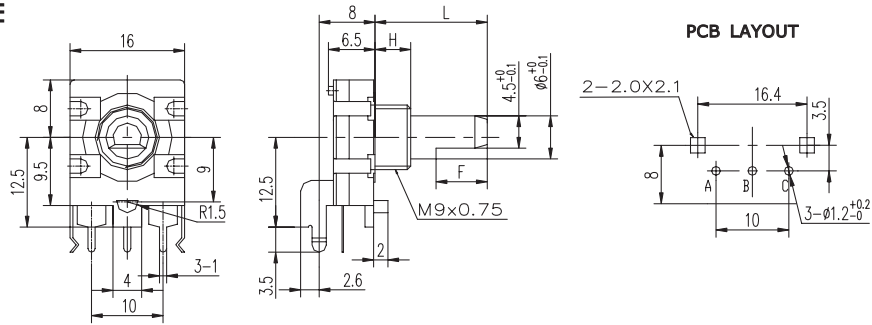

ACZ16BRXE

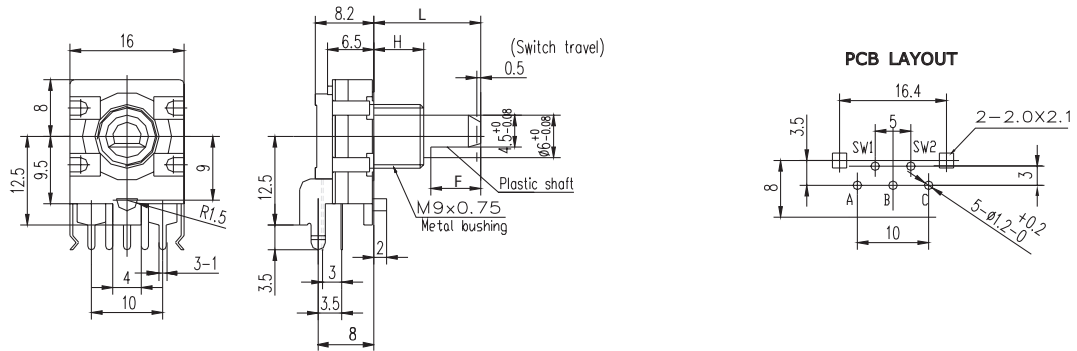

MECHANICAL DRAWING (VERTICAL)

ACZ16NBRXE

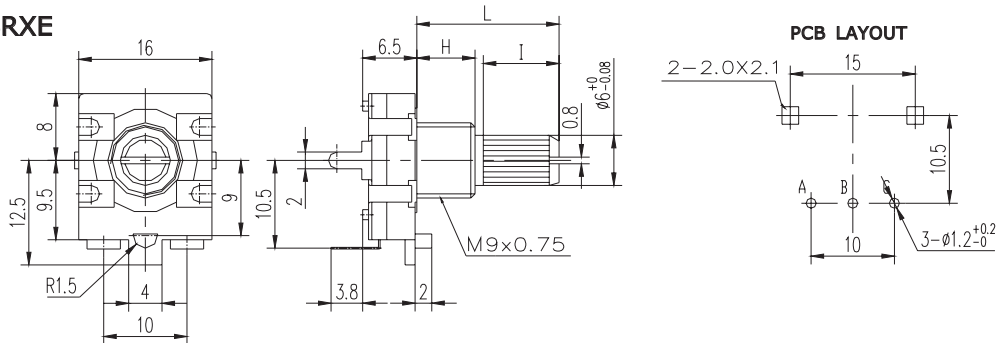

ACZ16BRXE

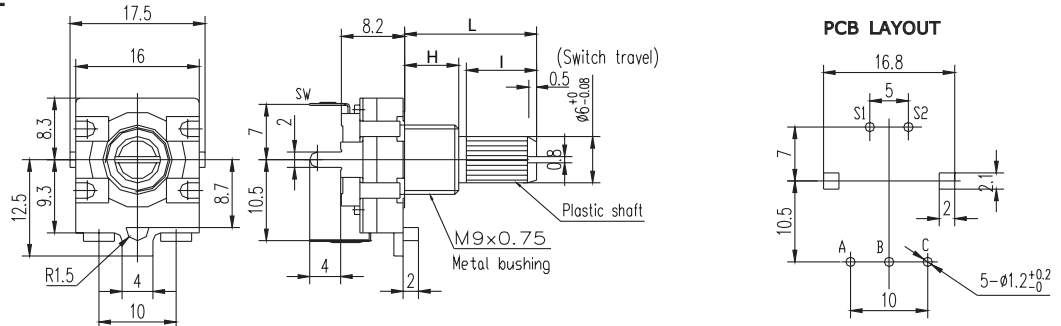

REVISION HISTORY

rev.	description	date
1.0	initial release	10/30/2009
1.01	added storage details	12/04/2014
1.02	brand update	10/04/2019
1.03	updated datasheet	06/15/2020
1.04	updated drawings	07/14/2020
1.05	logo, datasheet style update	09/08/2022

The revision history provided is for informational purposes only and is believed to be accurate.



CUI Devices offers a one (1) year limited warranty. Complete warranty information is listed on our website.

CUI Devices reserves the right to make changes to the product at any time without notice. Information provided by CUI Devices is believed to be accurate and reliable. However, no responsibility is assumed by CUI Devices for its use, nor for any infringements of patents or other rights of third parties which may result from its use.

CUI Devices products are not authorized or warranted for use as critical components in equipment that requires an extremely high level of reliability. A critical component is any component of a life support device or system whose failure to perform can be reasonably expected to cause the failure of the life support device or system, or to affect its safety or effectiveness.

cuidevices.com

Looking for pricing, stock, or lifecycle information?

Click below to explore more details on WIN SOURCE:

- ⊖ [View ACZ16NBR1E-15FD1-24C on WIN SOURCE](#)
- ⊖ [CUI Inc. Information](#)

Optimize Your Supply Chain with WIN SOURCE Solutions

- ✓ Global Sourcing Solution
- ✓ Obsolete Management
- ✓ Cost Control Management
- ✓ Shortage Management
- ✓ Alternative Solution
- ✓ Excess Inventory Management