



**THE DATASHEET OF
ACMS-Q3225-220-T**





Automotive signal Common Mode Chokes

ACMS-Q3225

Request Samples



Check Inventory



3.2 x 2.5 x 2.5 mm
RoHS/RoHS II Compliant
MSL Level = 1

Features

- AEC-Q200 compliant
- PPAP ready and supported
- Manufactured in TS/IATF 16949 production lines
- Excellent impedance characteristics
- Inductance values from 11 μ H to 100 μ H

Applications

- Differential signal line common mode noise suppression.
- Multimedia devices
- Automotive applications such as ADAS, Infotainment, Sensing, TCU

Electrical Specifications

Part Number	Impedance (Ω) @10MHz		Inductance (μ H) (+50/-30%)	DCR (m Ω)	Rated Current (A)	Rated Voltage (Vdc)	Insulation Resistance (M Ω)
	Min	Typ.		Max	Max	Max	Min
ACMS-Q3225-110	300	550	11	400	0.3	80	10
ACMS-Q3225-220	500	1100	22	500	0.25	80	10
ACMS-Q3225-510	1000	2600	51	700	0.2	80	10
ACMS-Q3225-101	2200	5100	100	1500	0.15	80	10

Rated Current is based on an Irms temperature rise of 40°C

Inductance Test Conditions: 0.1V/100KHz

ACMS-Q3225 is AEC-Q200 Automotive certified

ACMS-Q3225 Series is RoHS Compliant and Pb free

Operating Temperature: -55°C to +150°C (Including self-heating)

Storage Temperature (on PCB): -55°C to +150°C

Storage (in original packaging): <40°C, <60% RH



5101 Hidden Creek Ln, Spicewood TX 78669
Phone: 512-371-6159 Fax: 512-351-8858
For terms and conditions of sales, please visit:
www.abracon.com

REVISION A 8/22/2023

ABRACON IS
ISO9001-2015
CERTIFIED



Automotive signal Common Mode Chokes

ACMS-Q3225

Request Samples



Check Inventory



3.2 x 2.5 x 2.5 mm
RoHS/RoHS II Compliant
MSL Level = 1

Electrical Specifications

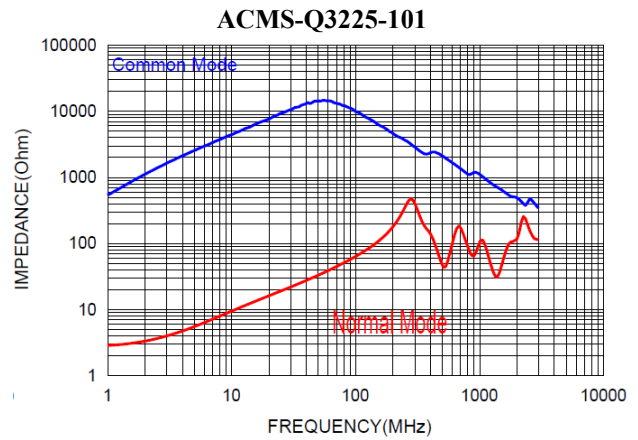
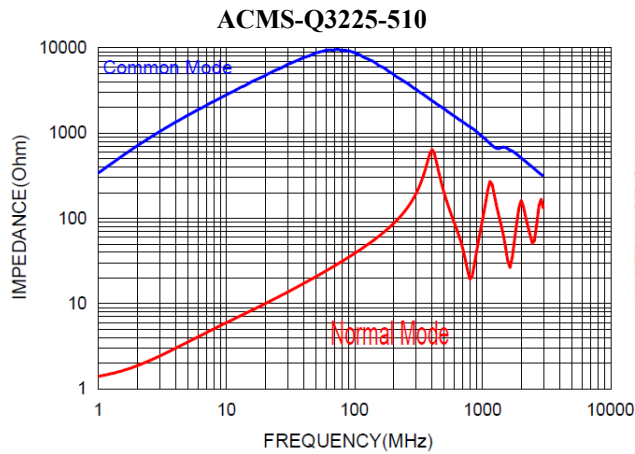
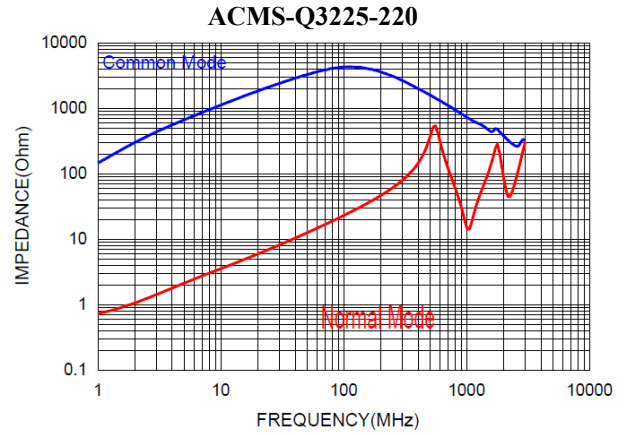
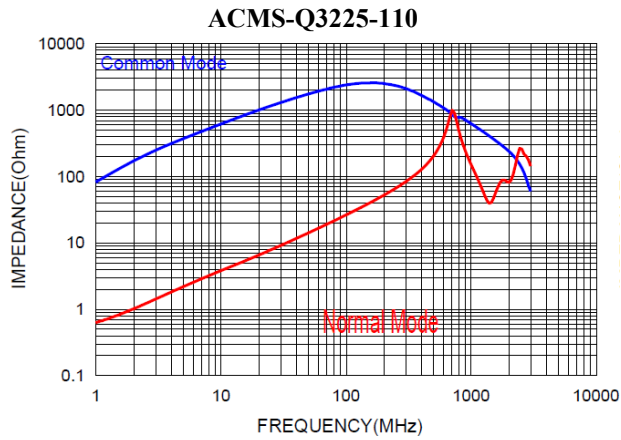

5101 Hidden Creek Ln, Spicewood TX 78669
Phone: 512-371-6159 Fax: 512-351-8858
For terms and conditions of sales, please visit:
www.abracon.com

REVISION A 8/22/2023

ABRACON IS
ISO9001-2015
CERTIFIED



Automotive signal Common Mode Chokes

ACMS-Q3225

Request Samples

Check Inventory

3.2 x 2.5 x 2.5 mm
RoHS/RoHS II Compliant
 MSL Level = 1

Mechanical Specifications

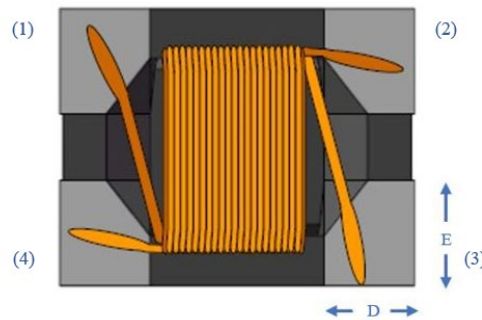
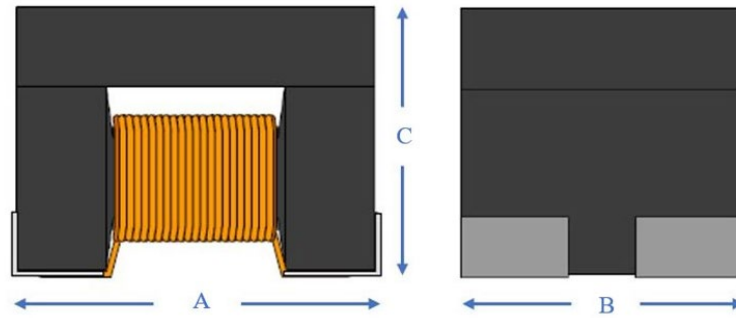

A	B	C	D	E
3.20 ±0.3	2.5 ±0.2	2.5 Max	0.55 ±0.15	0.75 ±0.2

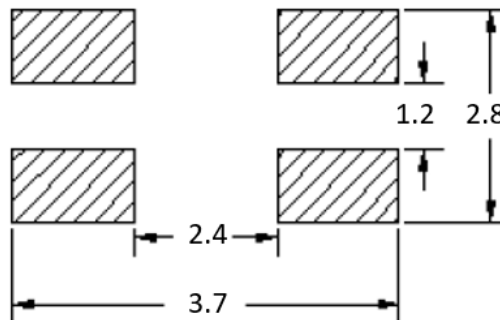

Recommended Layout

Dimensions: mm



Automotive signal Common Mode Chokes

ACMS-Q3225

Request Samples



Check Inventory



3.2 x 2.5 x 2.5 mm
RoHS/RoHS II Compliant
 MSL Level = 1

Schematic

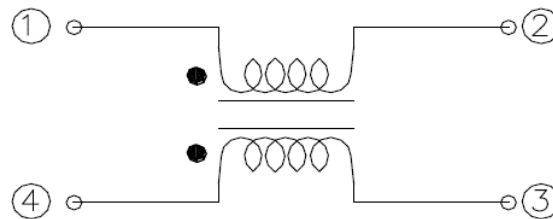

Materials

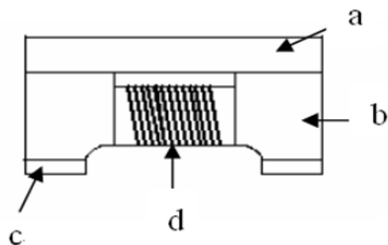

	Description	Specification
a	Upper Plate	Ferrite
b	Core	Ferrite Core
c	Electrode	Ag/Ni/Sn
d	Wire	Enameled Copper Wire

Part Identification

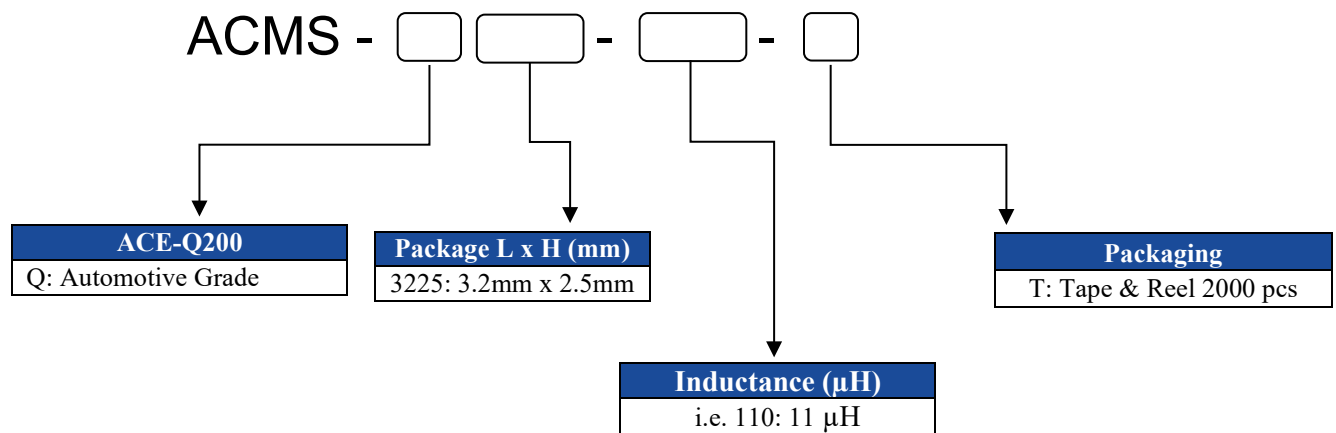



Automotive signal Common Mode Chokes

ACMS-Q3225

Request Samples



Check Inventory



3.2 x 2.5 x 2.5 mm
 RoHS/RoHS II Compliant
 MSL Level = 1

Reflow Profile

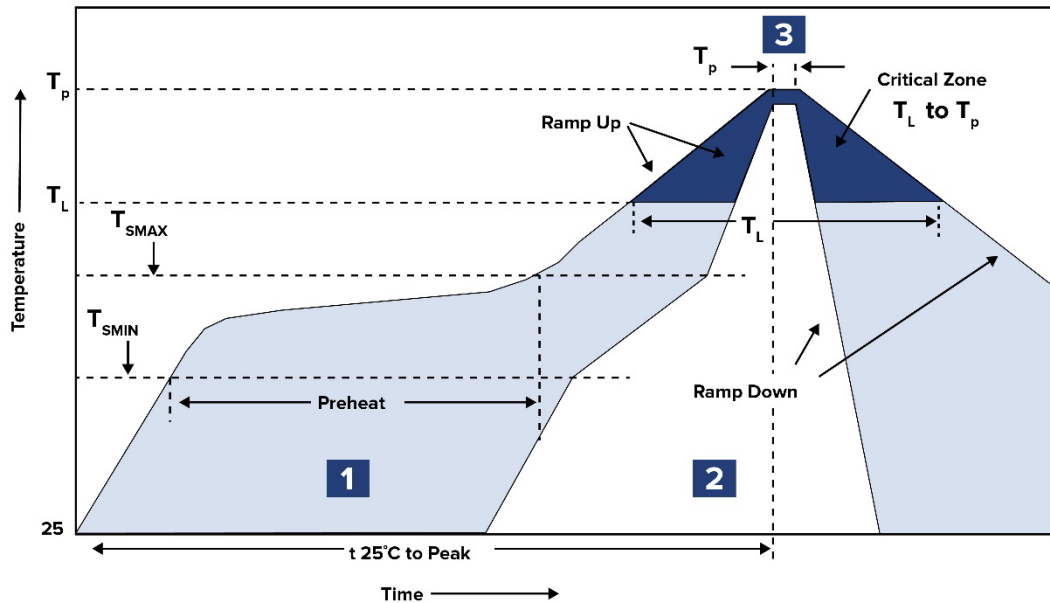

Zone	Description	Temperature	Times
1	Preheat	$T_{SMIN} \sim T_{SMAX}$ 150°C ~ 200°C	60 ~ 120 sec.
2	Reflow	T_L 217°C	60 ~ 150 sec.
3	Peak heat	T_p 250°C ± 5°C	30 sec. MAX



Automotive signal Common Mode Chokes

ACMS-Q3225

Request Samples



Check Inventory



3.2 x 2.5 x 2.5 mm
RoHS/RoHS II Compliant
 MSL Level = 1

Packaging

Tape & Reel: 2000pcs/reel

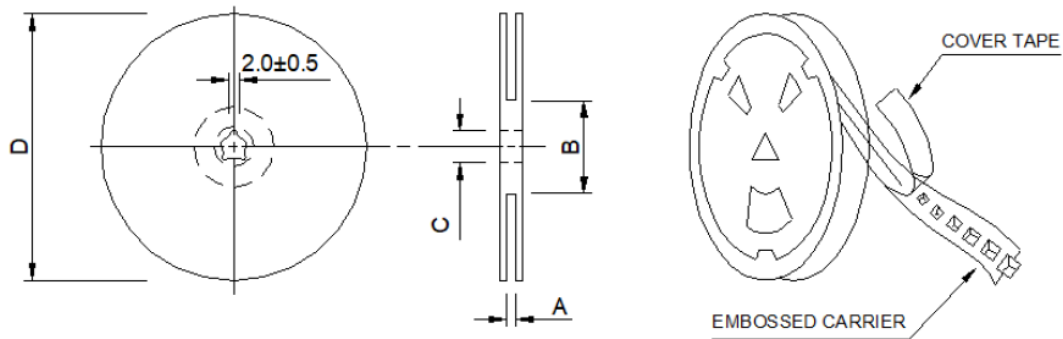

Series	A	B	C	D
ACMS-Q3225	9.0 ± 0.5	60.0 ± 2.0	13.5 ± 0.5	178 ± 2.0

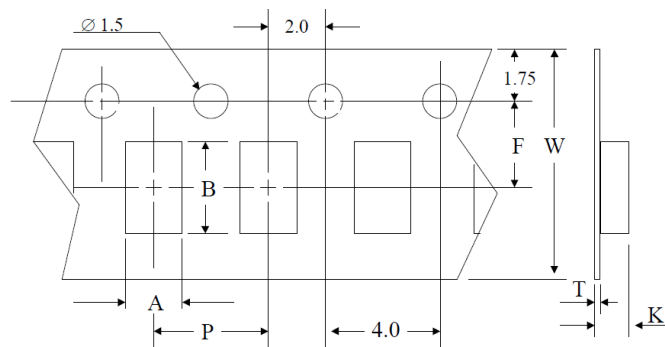

W	P	F	P0	B	A	K	D	D1	t
8.0	4.0	3.5	4.0	3.72	2.88	2.5	1.5	1.00	0.26
± 0.10	± 0.10	± 0.10	± 0.10	± 0.10	± 0.10	± 0.10	+0.10/-0	± 0.10	± 0.05

Dimensions: mm

ATTENTION: Abracon LLC's products are COTS – Commercial-Off-The-Shelf products; suitable for Commercial, Industrial and, where designated, Automotive Applications. Abracon's products are not specifically designed for Military, Aviation, Aerospace, Life-dependent Medical applications or any application requiring high reliability where component failure could result in loss of life and/or property. For applications requiring high reliability and/or presenting an extreme operating environment, written consent and authorization from Abracon LLC is required. Please contact Abracon LLC for more information.



5101 Hidden Creek Ln, Spicewood TX 78669
 Phone: 512-371-6159 Fax: 512-351-8858
 For terms and conditions of sales, please visit:
www.abracon.com

REVISION A 8/22/2023

ABRACON IS
 ISO9001-2015
 CERTIFIED

Looking for pricing, stock, or lifecycle information?

Click below to explore more details on WIN SOURCE:

 [View ACMS-Q3225-220-T on WIN SOURCE](#)

 [Abracon LLC Information](#)

Optimize Your Supply Chain with WIN SOURCE Solutions

-  Global Sourcing Solution
-  Obsolete Management
-  Cost Control Management
-  Shortage Management
-  Alternative Solution
-  Excess Inventory Management