



**THE DATASHEET OF
ABC201-1T12G**



ABC201 Series

Open Frame Power Supplies

Not For New Design
Please refer to exact equivalent product series
WLT200

The ABC201 Series of open-frame power supplies, with its wide universal 90-264 VAC input range and high power density, is available at 200 W of output power and a variety of single output voltages.

The high efficiency and high power density of the ABC family ensures minimal power loss in end-use equipment, thereby facilitating higher reliability, easier thermal management and meets regulatory approvals for environmentally-friendly end products.

These power supplies are ideal for telecom, datacom, industrial equipment and other applications.



Key Features & Benefits

- 5 x 3 x 1.5 Inch Form Factor
- 200 W with Forced Air Cooling
- High Efficiency > 88%
- 12 V Fan Output
- 5 V Standby Output
- Remote Sense
- Output Voltage Adjustability
- IEC Protection Class Options:
 - Class I: Earthing Tab J4 (no suffix)
 - Class II: No Earthing Tab (-2 suffix)
- IEC / EN / UL 62368-1 Compliant
- Metal Cover Kit Available (optional accessory)

Applications

- Instrumentation
- Lighting
- Industrial Applications
- Renewable Energy
- Test and Measurement
- Robotics



bel POWER
SOLUTIONS &
PROTECTION

a bel group

belfuse.com/power-solutions

- Applied Computing
- Wireless Communication

1. MODEL SELECTION

MODEL ¹	CONNECTOR	OUTPUT VOLTAGE	MAX LOAD ²		MIN LOAD	POWER
			CONVECTION	300 LFM		
ABC201-1005G	JST (Header)	5 VDC	16.67 A	26.0 A	0.0 A	130 W
ABC201-1T05G	Screw Terminal			35.0 A		175 W
ABC201-1012G	JST (Header)	12 VDC	13.33 A	16.67 A	0.0 A	200 W
ABC201-1T12G	Screw Terminal			16.67 A		200 W
ABC201-1015G	JST (Header)	15 VDC	10.67 A	13.33 A	0.0 A	200 W
ABC201-1T15G	Screw Terminal			13.33 A		200 W
ABC201-1024G	JST (Header)	24 VDC	6.67 A	8.33 A	0.0 A	200 W
ABC201-1T24G	Screw Terminal			8.33 A		200 W
ABC201-1030G	JST (Header)	30 VDC	5.33 A	6.67 A	0.0 A	200 W
ABC201-1T30G	Screw Terminal			6.67 A		200 W
ABC201-1048G	JST (Header)	48 VDC	3.33 A	4.17 A	0.0 A	200 W
ABC201-1T48G	Screw Terminal			4.17 A		200 W
COVER-201-XBC ³	Metal Cover Kit (accessory)					

¹ Class I products have an Earthing tab. For Class II version (without Earthing tab) add suffix -2 (e.g.: ABC201-1012G-2).

² Combined output power from V1, VSTBY and VFAN should not exceed the total output power rating.

³ When used in Cover Kit, de-rate output power to 70 % under all operating conditions.

2. INPUT SPECIFICATIONS

Specifications are for nominal input voltage, 25°C unless otherwise stated.

PARAMETER	DESCRIPTION / CONDITION	SPECIFICATION
Input Voltage	Universal	90 – 264 VAC / 120 – 390 VDC
Input Frequency		47 – 63 Hz
Input Current	120 VAC: 230 VAC:	2.4 A max. 1.2 A max.
Inrush Current	120 VAC: 230 VAC:	35 A max. 65 A max.
Leakage Current	120 VAC: 230 VAC:	< 150 µA < 300 µA
No Load Power		0.8 W
Switching Frequency	PFC converter (variable) Resonant converter (variable)	35 to 250 kHz, 90 kHz typical 35 to 250 kHz, 90 kHz typical

3. OUTPUT SPECIFICATIONS

PARAMETER	DESCRIPTION / CONDITION	SPECIFICATION
Output Voltage	Refer to Model Selection table	5 V to 48 V
Output Power ⁴	Peak Power: 250 W for 2 s	160 to 200 W
Fan Output ⁵	@ 5 A	12 V
Efficiency	120 VAC: 230 VAC:	84% typical 86% typical
Hold Up Time	120 VAC / 230 VAC:	10 ms
Power Factor	120 VAC: 230 VAC:	0.99 0.95
Line Regulation		± 0.5%
Load Regulation		± 2.0%
Transient Response	50 to 100% load change, 50 Hz, 50% duty cycle, 0.1 A / μ s	< 10%, recovery time < 5 ms
Ripple ⁶	All outputs	1.0 % max
Rise Time		< 100 ms
Set Point Accuracy	Main output	± 1%
Output Voltage Adjustment	V1	± 3 %
Over Current Protection		110% typical above rating
Over Voltage Protection	V1	110 to 150%
Short Circuit Protection	Short term, Automatic recovery	
Cooling	Convection 300 LFM	83 W (5 V model), 160 W (other models) 175 W (5 V model), 200 W (other models)

⁴ Derate output power linearly to 80% from 90 VAC to 80 VAC input.

⁵ Fan output voltage tolerance is +/-20%. During V1 full load, VFAN needs min. 20 mA load to be within regulation band. Peak current for fan output is 1 A.

⁶ Ripple is 2% up to 20% load and < 1% above 20% load. Ripple is peak to peak with 20 MHz bandwidth and 10 μ F (Electrolytic capacitor) in parallel with a 0.1 μ F capacitor at rated line voltage and load ranges.

4. EMC SPECIFICATIONS

PARAMETER	DESCRIPTION / CONDITION	SPECIFICATION
Conducted Emissions	EN 55032-B, CISPR22-B, FCC PART15-B	Pass
Radiated Emissions	EN 55032 B	Pass
Input Current Harmonics	EN 61000-3-2	Class D
Voltage Fluctuation and Flicker	EN 61000-3-3	Pass
ESD Immunity	EN 61000-4-2	Level 3, Criterion A
Radiated Field Immunity	EN 61000-4-3	Level 3, Criterion A
Electrical Fast Transient Immunity	EN 61000-4-4	Level 3, Criterion A
Surge Immunity	EN 61000-4-5	Level 3, Criterion A
Conducted Immunity	EN 61000-4-6	Level 3, Criterion A
Magnetic Field Immunity	EN 61000-4-8	Level 3, Criterion A
Voltage Dips, Interruptions	EN 61000-4-11	Criterion A & B

5. SAFETY SPECIFICATIONS

PARAMETER	DESCRIPTION / CONDITION	SPECIFICATION
Isolation Voltage	Input to Output:	Min. 4000 VDC
Safety Standards	EN / IEC / UL 62368-1 (Ed.3)	
Agency Approvals	Nemko, UL	
CE mark	Complies with LVD Directive	

6. ENVIRONMENTAL SPECIFICATIONS

PARAMETER	DESCRIPTION / CONDITION	SPECIFICATION
Operating Temperature ⁷	-20 to 0°C start-up is guaranteed	-20 to 70°C
Storage Temperature		-40 to 85° C
Humidity	Non Condensing	95%
Altitude	Operating: Non-Operating:	10,000 ft. 40,000 ft.
Reliability	MTBF according to Telcordia –SR332-Issue 3	1.6 million hours

⁷ Refer to derating curves

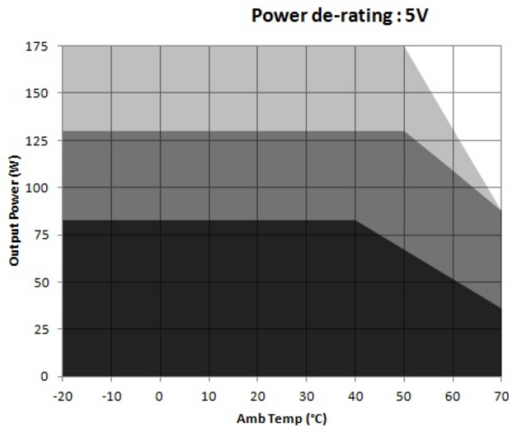

Convection load: 83 W up to 40 °C
De-rate above 40 °C @ 1.89% per °C

Forced air cooled load: 130 W up to 50°C
(for screw terminal version)
De-rate above 50 °C @ 1.63% per °C

Forced air cooled load: 175 W up to 50°C
(for JST connector version)
De-rate above 50 °C @ 2.5% per °C

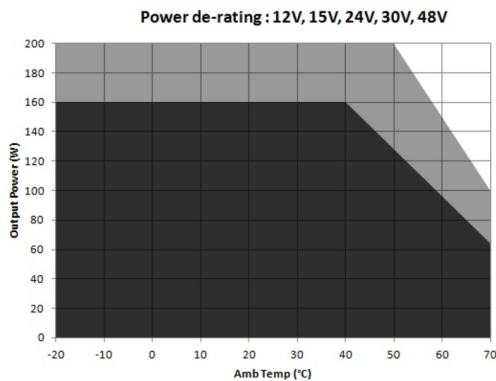

Convection load: 160 W up to 40 °C
De-rate above 40 °C @ 2% per °C

Forced air cooled load: 200 W up to 50°C
De-rate above 50 °C @ 2.5% per °C

Figure 1. Derating Curves

7. SIGNALS

PARAMETER	DESCRIPTION / CONDITION
Power Good Signal	TTL signal goes high after main output is in regulation band. Delay is 0.1 to 0.3 sec.
Power Fail Signal	TTL signal goes low 1 ms advance before output goes out of regulation due to mains failure
Remote Sense	Compensates for 200 mV cable drop
Remote ON / OFF	To turn on PSU short remote pin to ground

8. CONNECTOR & PIN DESCRIPTION

CONNECTOR	PIN	DESCRIPTION / CONDITION	MANUFACTURER / PN
AC Input Connector	J1	Pin 1 AC Neutral Pin 2 AC Line	Molex: 26-60-4030 or equivalent; Mating: 09-50-3031; Pins: 08-50-0106
DC Output Connector	J2	Pin 1,2,3 RTN Pin 4,5,6 Vout	Option 1: Tyco: 2-1776112-3 or equivalent Mating: 13 AWG wire Option 2: JST: B6P-VH-B (LF) (SN) or B6P-VH (LF) (SN) or equivalent Mating: VHR-6M; Pins: SVH-41T-P1.1
Signals & Aux Power ⁸	J3	Pin 1 +VE Remote Sense Pin 2 VFAN (+12 V/0.5 A) Pin 3 -VE Remote Sense Pin 4 Remote ON/OFF Pin 5 VSTBY (+5 V/1 A, +/-5%) Pin 6 RTN (Signal) Pin 7 Power Fail Pin 8 Power Good	Molex: 22-23-2081 or equivalent Mating: 22-01-2087, Pins: 08-50-0113
Earth ⁸ (Spade Connector)	J4		Molex: 19705-4301 or equivalent Mating: 190030001

- ⁸ PSU is supplied with J3 housing, pin-4 and pin-6 shorted to enable main output without remote on/off feature
⁹ Class I product only

9. MECHANICAL SPECIFICATIONS

PARAMETER	DESCRIPTION / CONDITION
Weight	325 g (0.72 lbs.)
Dimensions	127.0 x 76.2 x 38.1 mm (5 x 3 x 1.5 in)

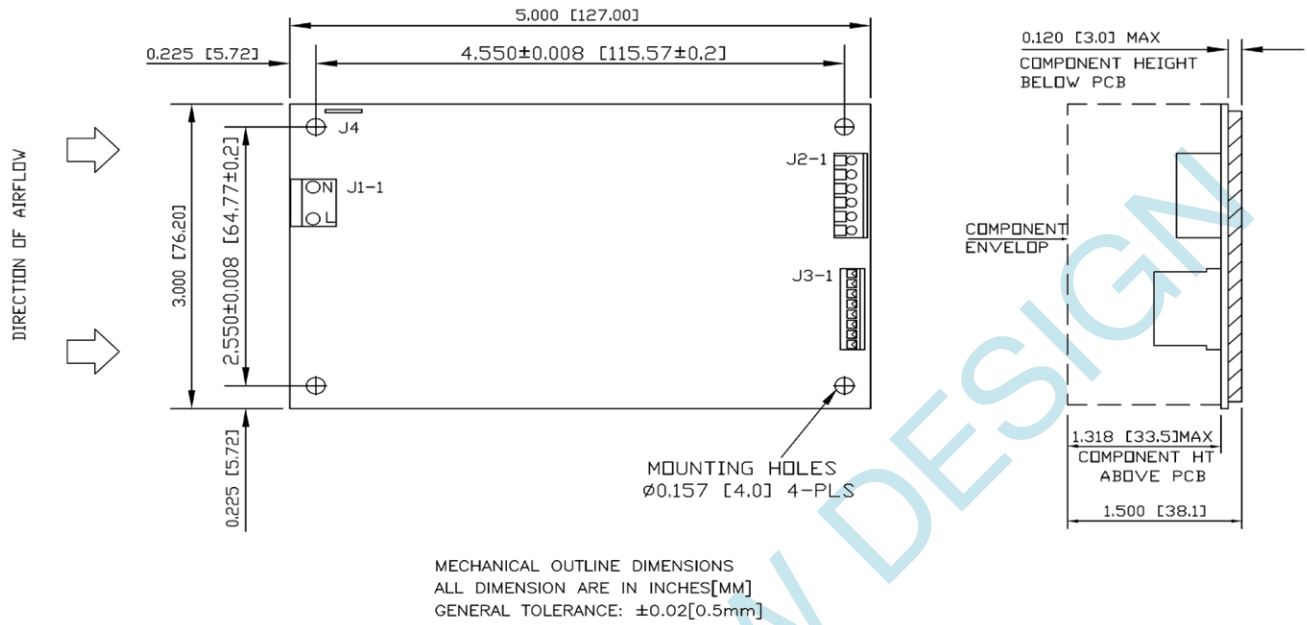

Figure 2. Mechanical Drawing

NOTES: In case the PCB is mounted in a metal enclosure, using metal hardware ensure the following:
 Stand off, used to mount PCB has OD of 5.4 mm max.
 Screws, used to fix PCB on stand off, have head dia of 6.0 mm max.
 Washer, if used, to have dia of 6.5 mm max.

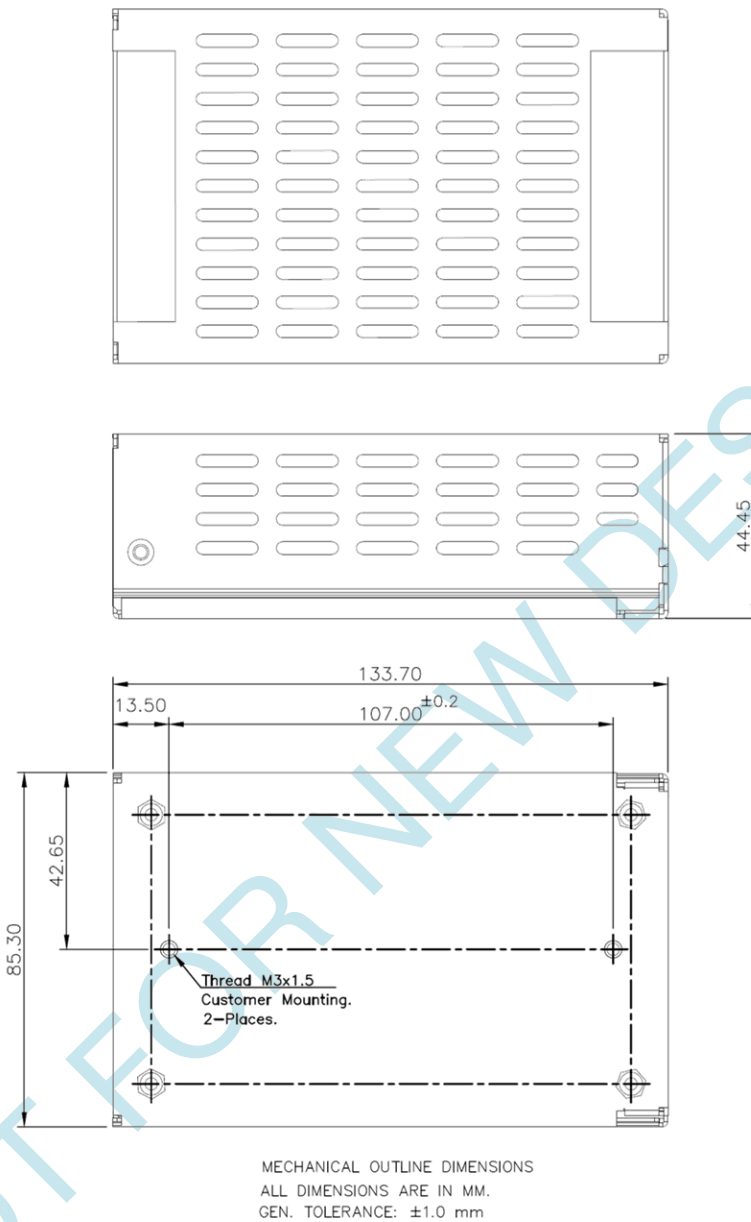

Figure 3. Mechanical Drawing with Cover Kit

For more information on these products consult: tech.support@psbel.com

NUCLEAR AND MEDICAL APPLICATIONS - Products are not designed or intended for use as critical components in life support systems, equipment used in hazardous environments, or nuclear control systems.

TECHNICAL REVISIONS - The appearance of products, including safety agency certifications pictured on labels, may change depending on the date manufactured. Specifications are subject to change without notice.

Looking for pricing, stock, or lifecycle information?

Click below to explore more details on WIN SOURCE:

- ⊖ [View ABC201-1T12G on WIN SOURCE](#)
- ⊖ [Bel Power Solutions Information](#)

Optimize Your Supply Chain with WIN SOURCE Solutions

- ✓ Global Sourcing Solution
- ✓ Obsolete Management
- ✓ Cost Control Management
- ✓ Shortage Management
- ✓ Alternative Solution
- ✓ Excess Inventory Management