



**THE DATASHEET OF  
9FG430AGILFT**



# Four Output Differential Frequency Generator for PCIe Gen3 and QPI

9FG430

## General Description:

The 9FG430 is a Frequency Timing Generator that provides 4 HCSL differential output pairs. These outputs support PCI-Express Gen3, and QPI applications. The part supports Spread Spectrum and synthesizes several additional output frequencies from either a 14.31818 MHz crystal, a 25 MHz crystal or reference input clock. The 9FG430 also outputs a copy of the reference clock. Complete control of the device is available via strapping pins or via the SMBus interface.

## Recommended Application:

4 Output Differential Frequency Generator for PCIe Gen3 and QPI

## Output Features:

- 4 - 0.7V current mode differential HCSL output pairs
- 1 - 3.3V LVTTTL REF output

## Features/Benefits:

- Pin-to-Pin with 9FG104D/Easy upgrade to PCIe Gen3
- Generates common frequencies from 14.318 MHz or 25 MHz; single part supports multiple applications
- Provides copy of reference output; eliminates need for additional crystal or oscillator
- Unused outputs may be disabled in Hi-Z; save system power
- Device may be configured by SMBus and/or strap pins; can be used in systems without SMBus

## Key Specifications:

- Cycle-to-cycle jitter: < 50ps with 25MHz input
- Output-to-output skew: <50ps
- Phase jitter: PCIe Gen3 < 1ps rms
- Phase jitter: QPI 9.6GB/s < 0.2ps rms
- 10 ppm synthesis error with 25MHz input and Spread Off

## Functional Block Diagram

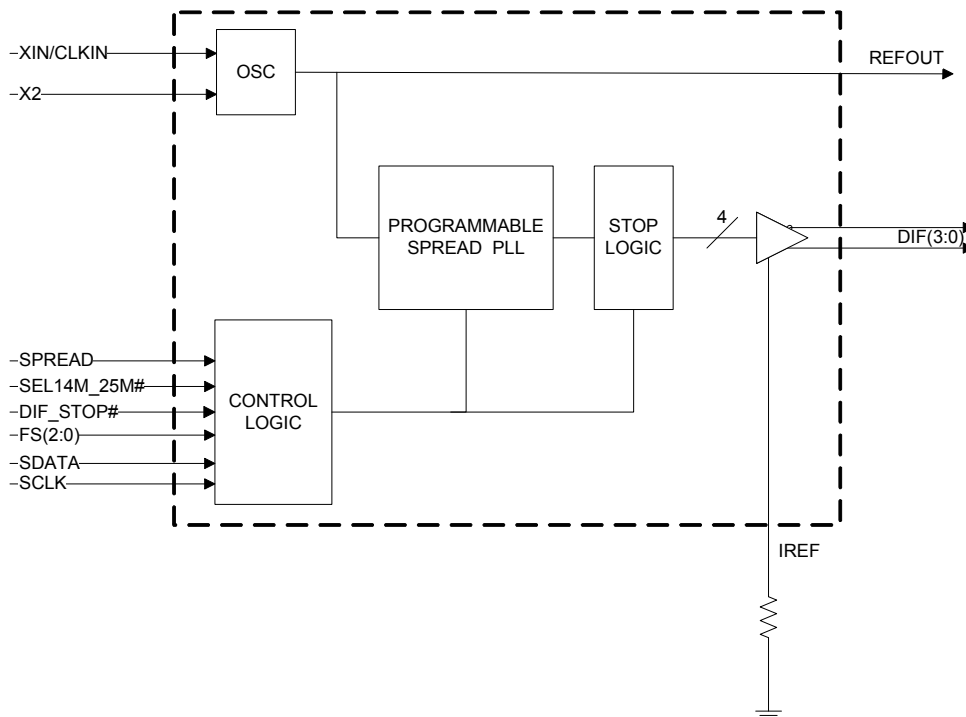

## Pin Configuration

XIN/CLKIN	1	<b>9FG430</b>	28	VDDA
X2	2		27	GND
VDD	3		26	IREF
GND	4		25	vFS0
REFOUT	5		24	vFS1
vFS2	6		23	DIF_0
DIF_3	7		22	DIF_0#
DIF_3#	8		21	VDD
VDD	9		20	GND
GND	10		19	DIF_1
DIF_2	11		18	DIF_1#
DIF_2#	12		17	^SEL14M_25M#
SDATA	13		16	vSPREAD
SCLK	14		15	DIF_STOP#

^ indicates internal 120K pull up

v indicates internal 120K pull down

## Power Groups

Pin Number		Description
VDD	GND	
3	4	REFOUT, Digital Inputs
9,21	10,20	DIF Outputs
28	27	IREF, Analog VDD, GND for PLL Core

## Frequency Select Table

SEL14M_25M# (FS3)	FS2	FS1	FS0	OUTPUT (MHz)
0	0	0	0	100.00
0	0	0	1	125.00
0	0	1	0	133.33
0	0	1	1	166.67
0	1	0	0	200.00
0	1	0	1	266.67
0	1	1	0	333.33
0	1	1	1	400.00
1	0	0	0	100.00
1	0	0	1	125.00
1	0	1	0	133.33
1	0	1	1	166.67
1	1	0	0	200.00
1	1	0	1	266.67
1	1	1	0	333.33
1	1	1	1	400.00

## Pin Description

PIN #	PIN NAME	PIN TYPE	DESCRIPTION
1	XIN/CLKIN	IN	Crystal input or Reference Clock input
2	X2	OUT	Crystal output, Nominally 14.318MHz
3	VDD	PWR	Power supply, nominal 3.3V
4	GND	PWR	Ground pin.
5	REFOUT	OUT	Reference Clock output
6	vFS2	IN	Frequency select pin. This pin has an internal 120k pull down resistor
7	DIF_3	OUT	0.7V differential true clock output
8	DIF_3#	OUT	0.7V differential Complementary clock output
9	VDD	PWR	Power supply, nominal 3.3V
10	GND	PWR	Ground pin.
11	DIF_2	OUT	0.7V differential true clock output
12	DIF_2#	OUT	0.7V differential Complementary clock output
13	SDATA	I/O	Data pin for SMBus circuitry, 5V tolerant.
14	SCLK	IN	Clock pin of SMBus circuitry, 5V tolerant.
15	DIF_STOP#	IN	Active low input to stop differential output clocks.
16	vSPREAD	IN	Asynchronous, active high input to enable spread spectrum functionality. This pin has a 120Kohm pull down resistor.
17	^SEL14M_25M#	IN	Select 14.31818 MHz or 25 Mhz input frequency. This pin has an internal 120kohm pull up resistor. 1 = 14.31818 MHz, 0 = 25 MHz
18	DIF_1#	OUT	0.7V differential Complementary clock output
19	DIF_1	OUT	0.7V differential true clock output
20	GND	PWR	Ground pin.
21	VDD	PWR	Power supply, nominal 3.3V
22	DIF_0#	OUT	0.7V differential Complementary clock output
23	DIF_0	OUT	0.7V differential true clock output
24	vFS1	IN	Frequency select pin.
25	vFS0	IN	Frequency select pin.
26	IREF	OUT	This pin establishes the reference for the differential current-mode output pairs. It requires a fixed precision resistor to ground. 475ohm is the standard value for 100ohm differential impedance. Other impedances require different values. See data sheet.
27	GND A	PWR	Ground pin for the PLL core.
28	VDD A	PWR	3.3V power for the PLL core.

### Note:

^ indicates internal 120K pull up

v indicates internal 120K pull down

**Electrical Characteristics - Absolute Maximum Ratings**

PARAMETER	SYMBOL	CONDITIONS	MIN	TYP	MAX	UNITS	NOTES
3.3V Core Supply Voltage	VDDA				4.6	V	1,2
3.3V Logic Supply Voltage	VDD				4.6	V	1,2
Input Low Voltage	V <sub>IL</sub>		GND-0.5			V	1
Input High Voltage	V <sub>IH</sub>	Except for SMBus interface			V <sub>DD</sub> +0.5V	V	1
Input High Voltage	V <sub>IHSMB</sub>	SMBus clock and data pins			5.5V	V	1
Storage Temperature	T <sub>s</sub>		-65		150	°C	1
Junction Temperature	T <sub>j</sub>				125	°C	1
Input ESD protection	ESD prot	Human Body Model	2000			V	1

<sup>1</sup>Guaranteed by design and characterization, not 100% tested in production.

<sup>2</sup>Operation under these conditions is neither implied nor guaranteed.

**Electrical Characteristics - Input/Supply/Common Parameters**

TA = TCOM or TIND; Supply Voltage VDD = 3.3 V +/-5%; See Test Loads s for loading conditions.

PARAMETER	SYMBOL	CONDITIONS	MIN	TYP	MAX	UNITS	NOTES
Ambient Operating Temperature	T <sub>COM</sub>	Commercial range	0		70	°C	1
	T <sub>IND</sub>	Industrial range	-40		85	°C	1
Input High Voltage	V <sub>IH</sub>	Single-ended inputs, except SMBus, low threshold and tri-level inputs	2		V <sub>DD</sub> + 0.3	V	1
Input Low Voltage	V <sub>IL</sub>	Single-ended inputs, except SMBus, low threshold and tri-level inputs	GND - 0.3		0.8	V	1
Input Current	I <sub>IN</sub>	Single-ended inputs, V <sub>IN</sub> = GND, V <sub>IN</sub> = VDD	-5		5	uA	1
	I <sub>INP</sub>	Single-ended inputs V <sub>IN</sub> = 0 V; Inputs with internal pull-up resistors V <sub>IN</sub> = VDD; Inputs with internal pull-down resistors	-200		200	uA	1
Input Frequency	F <sub>in</sub>	SEL14M_25M# = 0		25		MHz	1
		SEL14M_25M# = 1		14.31818		MHz	1
Pin Inductance	L <sub>pin</sub>				7	nH	1
Capacitance	C <sub>IN</sub>	Logic Inputs, except DIF_IN	1.5		5	pF	1
	C <sub>INXTAL</sub>	Crystal inputs			6	pF	1,4
	C <sub>OUT</sub>	Output pin capacitance			6	pF	1
Clk Stabilization	T <sub>STAB</sub>	From V <sub>DD</sub> Power-Up and after input clock stabilization or de-assertion of PD# to 1st clock			1.8	ms	1,2
Input SS Modulation Frequency	f <sub>MODIN</sub>	Allowable Frequency (Triangular Modulation)	30		33	kHz	1
OE# Latency	t <sub>LATOE#</sub>	DIF start after OE# assertion DIF stop after OE# deassertion	1		3	cycles	1,3
Tdrive_PD#	t <sub>DRVPD</sub>	DIF output enable after PD# de-assertion			300	us	1,3
Tfall	t <sub>F</sub>	Fall time of control inputs			5	ns	1,2
Trise	t <sub>R</sub>	Rise time of control inputs			5	ns	1,2
SMBus Input Low Voltage	V <sub>ILSMB</sub>				0.8	V	1
SMBus Input High Voltage	V <sub>IHSMB</sub>		2.1		V <sub>DD</sub> SMB	V	1
SMBus Output Low Voltage	V <sub>OLSMB</sub>	@ I <sub>PULLUP</sub>			0.4	V	1
SMBus Sink Current	I <sub>PULLUP</sub>	@ V <sub>OL</sub>	4			mA	1
Nominal Bus Voltage	V <sub>DD</sub> SMB	3V to 5V +/- 10%	2.7		5.5	V	1
SCLK/SDATA Rise Time	t <sub>RSMB</sub>	(Max VIL - 0.15) to (Min VIH + 0.15)			1000	ns	1
SCLK/SDATA Fall Time	t <sub>FSMB</sub>	(Min VIH + 0.15) to (Max VIL - 0.15)			300	ns	1
SMBus Operating Frequency	f <sub>MAXSMB</sub>	Maximum SMBus operating frequency			100	kHz	1,5

<sup>1</sup>Guaranteed by design and characterization, not 100% tested in production.

<sup>2</sup>Control input must be monotonic from 20% to 80% of input swing.

<sup>3</sup>Time from deassertion until outputs are >200 mV

<sup>4</sup>DIF\_IN input

<sup>5</sup>The differential input clock must be running for the SMBus to be active

**Electrical Characteristics - DIF 0.7V Current Mode Differential Outputs**

TA = TCOM or TIND; Supply Voltage VDD = 3.3 V +/-5%; See Test Loads s for loading conditions.

PARAMETER	SYMBOL	CONDITIONS	MIN	TYP	MAX	UNITS	NOTES
Slew rate	Trf	Scope averaging on	1		4	V/ns	1, 2, 3
Slew rate matching	$\Delta$ Trf	Slew rate matching, Scope averaging on			20	%	1, 2, 4
Voltage High	VHigh	Statistical measurement on single-ended signal using oscilloscope math function. (Scope averaging on)	660		850	mV	1
Voltage Low	VLow		-150		150		1
Max Voltage	Vmax	Measurement on single ended signal using absolute value. (Scope averaging off)			1150	mV	1
Min Voltage	Vmin		-300				1
Vswing	Vswing	Scope averaging off	300			mV	1, 2
Crossing Voltage (abs)	Vcross_abs	Scope averaging off	250		550	mV	1, 5
Crossing Voltage (var)	$\Delta$ -Vcross	Scope averaging off			140	mV	1, 6

<sup>1</sup>Guaranteed by design and characterization, not 100% tested in production. IREF = VDD/(3xRR). For RR = 475 $\Omega$  (1%), IREF = 2.32mA.IOH = 6 x IREF and VOH = 0.7V @ ZO=50 $\Omega$  (100 $\Omega$  differential impedance).<sup>2</sup> Measured from differential waveform<sup>3</sup> Slew rate is measured through the Vswing voltage range centered around differential 0V. This results in a +/-150mV window around differential 0V.<sup>4</sup> Matching applies to rising edge rate of Clock / falling edge rate of Clock#. It is measured in a +/-75mV window centered on the average cross point where Clock rising meets Clock# falling. The median cross point is used to calculate the voltage thresholds the oscilloscope uses for the edge rate calculations.<sup>5</sup> Vcross is defined as voltage where Clock = Clock# measured on a component test board and only applies to the differential rising edge (i.e. Clock rising and Clock# falling).<sup>6</sup> The total variation of all Vcross measurements in any particular system. Note that this is a subset of V\_cross\_min/max (V\_cross absolute) allowed. The intent is to limit Vcross induced modulation by setting V\_cross\_delta to be smaller than V\_cross absolute.**Electrical Characteristics - Current Consumption**

TA = TCOM or TIND; Supply Voltage VDD = 3.3 V +/-5%, See Test Loads for loading

PARAMETER	SYMBOL	CONDITIONS	MIN	TYP	MAX	UNITS	NOTES
Operating Supply Current	IDD3.3	VDD, All outputs active @100MHz		80	95	mA	1
	IDDA3.3OP	VDDA, All outputs active @100MHz		25	30	mA	1
	IDD3.3	VDD, All outputs active @400MHz		100	120	mA	1
	IDDA3.3OP	VDDA, All outputs active @400MHz		25	30	mA	1
Powerdown Current	IDD3.3PD	VDD, All differential pairs driven		75	90	mA	1
	IDDA3.3PD	VDDA, All differential pairs driven		25	30	mA	1
	IDD3.3PDZ	VDD, All differential pairs tri-stated		25	30	mA	1
	IDDA3.3PDZ	VDDA, All differential pairs tri-stated		25	30	mA	1

<sup>1</sup>Guaranteed by design and characterization, not 100% tested in production.<sup>2</sup> IREF = VDD/(3xRR). For RR = 475 $\Omega$  (1%), IREF = 2.32mA. IOH = 6 x IREF and VOH = 0.7V @ ZO=50 $\Omega$ .**Electrical Characteristics - Output Duty Cycle, Jitter, and Skew Characteristics**

TA = TCOM or TIND; Supply Voltage VDD = 3.3 V +/-5%, See Test Loads for loading

PARAMETER	SYMBOL	CONDITIONS	MIN	TYP	MAX	UNITS	NOTES
Duty Cycle	tDC	Measured differentially, PLL Mode	45		55	%	1
Skew, Output to Output	tSK3	VT = 50%			50	ps	1
Jitter, Cycle to cycle	tjCyc-cyc	25M input			50	ps	1,3
Jitter, Cycle to cycle	tjCyc-cyc	14.318M input			60	ps	1,3

<sup>1</sup>Guaranteed by design and characterization, not 100% tested in production.<sup>2</sup> IREF = VDD/(3xRR). For RR = 475 $\Omega$  (1%), IREF = 2.32mA. IOH = 6 x IREF and VOH = 0.7V @ ZO=50 $\Omega$ .<sup>3</sup> Measured from differential waveform<sup>4</sup> Duty cycle distortion is the difference in duty cycle between the output and the input clock when the device is operated in bypass mode.

**Electrical Characteristics - Phase Jitter Parameters**TA = T<sub>COM</sub> or T<sub>IND</sub>; Supply Voltage VDD = 3.3 V +/-5%, See Test Loads for loading conditions

PARAMETER	SYMBOL	CONDITIONS	MIN	TYP	MAX	UNITS	Notes
Phase Jitter, PCI Express	t <sub>jphPCIeG1</sub>	PCIe Gen 1			86	ps (p-p)	1,2,3,6
	t <sub>jphPCIeG2</sub>	PCIe Gen 2 Lo Band 10kHz < f < 1.5MHz			3	ps (rms)	1,2,6
		PCIe Gen 2 High Band 1.5MHz < f < Nyquist (50MHz)			3.1	ps (rms)	1,2,6
	t <sub>jphPCIeG3</sub>	PCIe Gen 3 (PLL BW of 2-4MHz, CDR = 10MHz)			1	ps (rms)	1,2,4,5,6
Phase Jitter, QPI/SMI	t <sub>jphQPI_SMI</sub>	QPI & SMI (100MHz or 133MHz, 4.8Gb/s, 6.4Gb/s 12UI)			0.5	ps (rms)	1,5,6
		QPI & SMI (100MHz, 8.0Gb/s, 12UI)			0.3	ps (rms)	1,5,6
		QPI & SMI (100MHz, 9.6Gb/s, 12UI)			0.2	ps (rms)	1,5,6

<sup>1</sup> Guaranteed by design and characterization, not 100% tested in production.<sup>2</sup> See <http://www.pcisig.com> for complete specs<sup>3</sup> Sample size of at least 100K cycles. This figures extrapolates to 108ps pk-pk @ 1M cycles for a BER of 1-12.<sup>4</sup> Subject to final radification by PCI SIG.<sup>5</sup> Calculated from Intel-supplied Clock Jitter Tool v 1.6.3<sup>6</sup> Applies to all differential outputs**Electrical Characteristics - REF-14.318/25 MHz**TA = T<sub>COM</sub> or T<sub>IND</sub>; Supply Voltage VDD = 3.3 V +/-5%, See Test Loads for loading

PARAMETER	SYMBOL	CONDITIONS	MIN	TYP	MAX	UNITS	Notes
Long Accuracy	ppm	see T <sub>period</sub> min-max values		0		ppm	1
Clock period	T <sub>period</sub>	14.318MHz output nominal		69.8413		ns	1,2
Clock period	T <sub>period</sub>	25.000MHz output nominal		40		ns	1,2
Output High Voltage	V <sub>OH</sub>	I <sub>OH</sub> = -1 mA	2.4			V	1
Output Low Voltage	V <sub>OL</sub>	I <sub>OL</sub> = 1 mA			0.4	V	1
Output High Current	I <sub>OH</sub>	V <sub>OH</sub> @ MIN = 1.0 V, V <sub>OH</sub> @ MAX = 3.135 V	-29		-23	mA	1
Output Low Current	I <sub>OL</sub>	V <sub>OL</sub> @ MIN = 1.95 V, V <sub>OL</sub> @ MAX = 0.4 V	29		27	mA	1
Rise/Fall Time	t <sub>rf1</sub>	V <sub>OL</sub> = 0.4 V, V <sub>OH</sub> = 2.4 V	0.5	0.8	2	ns	1
Duty Cycle	d <sub>t1</sub>	V <sub>T</sub> = 1.5 V	45		55	%	1
Jitter	t <sub>jcy-cyc</sub>	V <sub>T</sub> = 1.5 V		250	400	ps	1

<sup>1</sup> Guaranteed by design and characterization, not 100% tested in production.<sup>2</sup> All Long Term Accuracy and Clock Period specifications are guaranteed assuming that REF is at 14.31818 or 25.00 MHz

Output Termination and Layout Information			
Common Recommendations for Differential Routing	Dimension or Value	Unit	Figure
L1 length, route as non-coupled 50ohm trace	0.5 max	inch	1
L2 length, route as non-coupled 50ohm trace	0.2 max	inch	1
L3 length, route as non-coupled 50ohm trace	0.2 max	inch	1
$R_s$	33	ohm	1
$R_t$	49.9	ohm	1

Down Device Differential Routing			
L4 length, route as coupled microstrip 100ohm differential trace	2 min to 16 max	inch	1
L4 length, route as coupled stripline 100ohm differential trace	1.8 min to 14.4 max	inch	1

Differential Routing to PCI Express Connector			
L4 length, route as coupled microstrip 100ohm differential trace	0.25 to 14 max	inch	2
L4 length, route as coupled stripline 100ohm differential trace	0.225 min to 12.6 max	inch	2

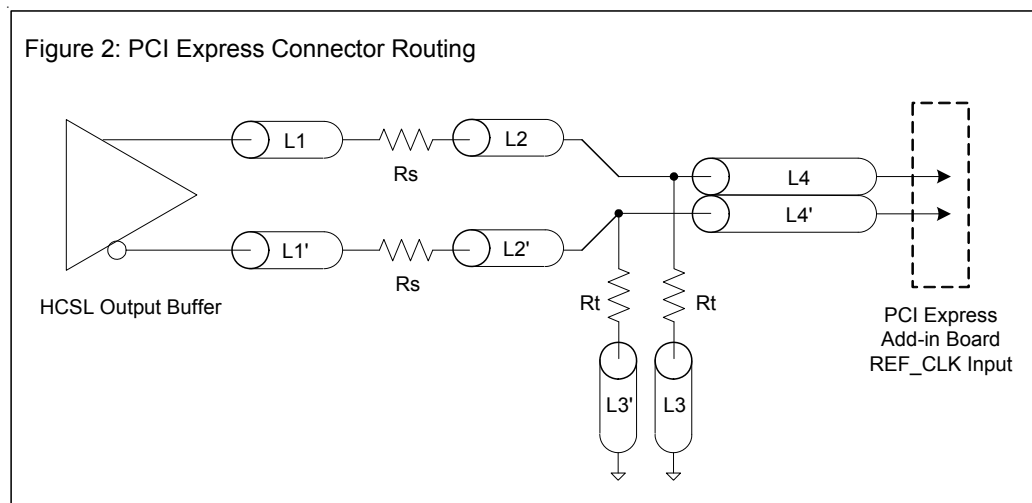
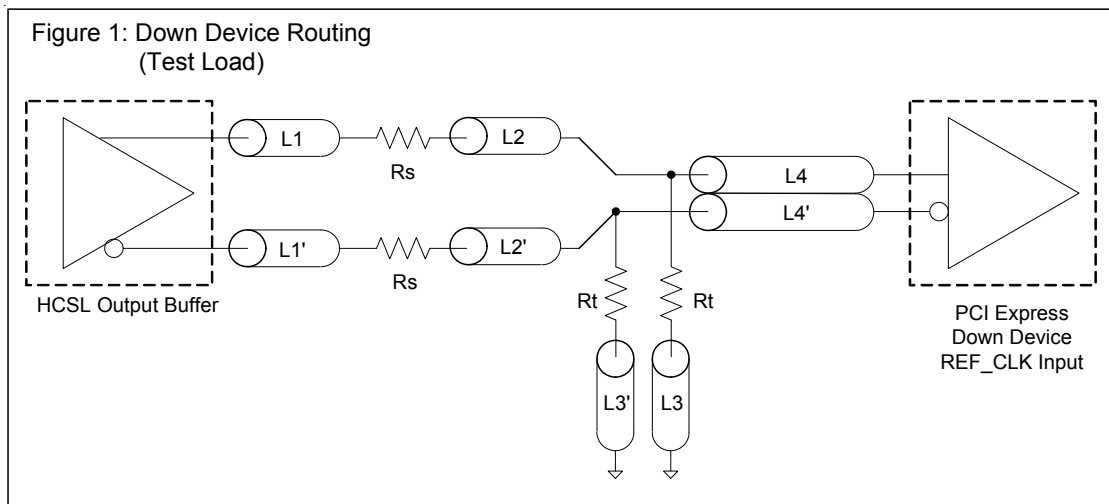

**Termination for LVDS and other Common Differential Signals (figure 3)**

Vdiff	Vp-p	Vcm	R1	R2	R3	R4	Note
0.45v	0.22v	1.08	33	150	100	100	
0.58	0.28	0.6	33	78.7	137	100	
0.80	0.40	0.6	33	78.7	none	100	ICS874003i-02 input compatible
0.60	0.3	1.2	33	174	140	100	Standard LVDS

R1a = R1b = R1

R2a = R2b = R2

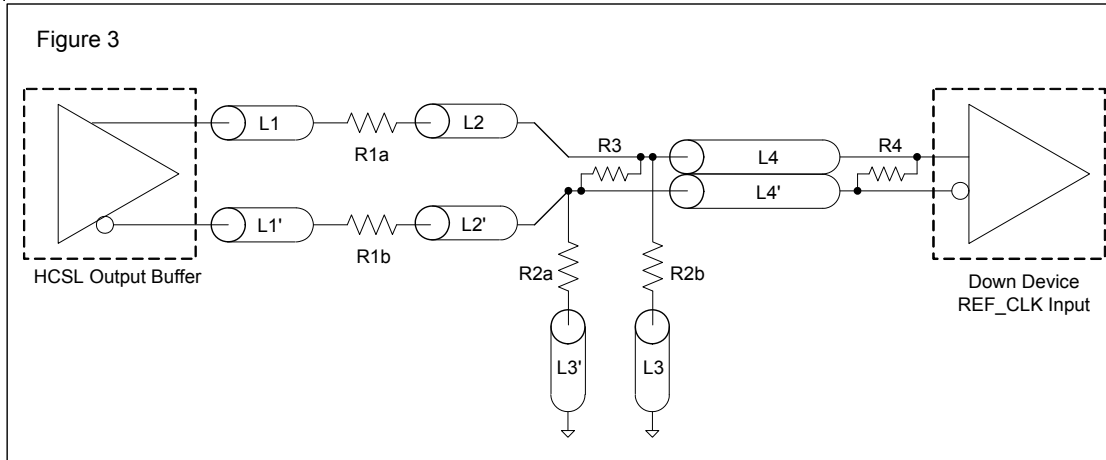

**Termination for Cable AC Coupled Application (figure 4)**

Component	Value	Note
R5a, R5b	8.2K 5%	
R6a, R6b	1K 5%	
Cc	0.1 μF	
Vcm	0.350 volts	

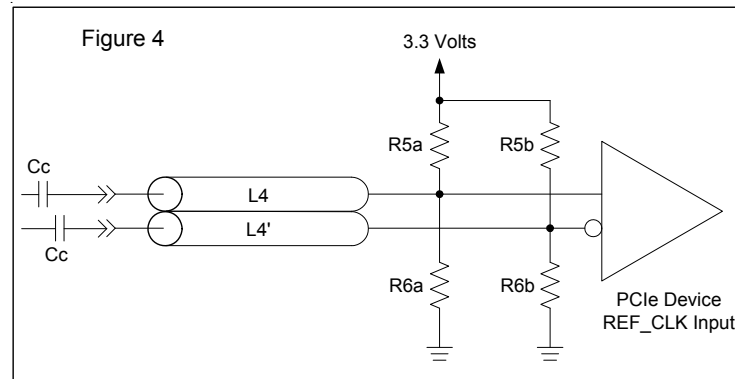
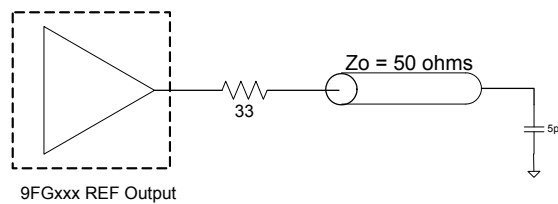

Figure 5. REF Output Test Load



## Differential Clock Tolerances x1 = 25MHz

## Clock Periods - Differential Outputs with Spread Spectrum Disabled

SSC OFF or SSC +/- 0.25% Center Spread	Synthesis Error (ppm)	Center Freq. MHz	Measurement Window							Units	Notes
			1 Clock	1us	0.1s	0.1s	0.1s	1us	1 Clock		
			-c2c jitter AbsPer Min	-SSC Short-Term Average Min	- ppm Long-Term Average Min	0 ppm Period Nominal	+ ppm Long-Term Average Max	+SSC Short- Term Average Max	+c2c jitter AbsPer Max		
DIF	0	100.00	9.95000		10.00000	10.00000	10.00000		10.05000	ns	1,2
	0	125.00	7.95000		8.00000	8.00000	8.00000		8.05000	ns	1,2
	0	133.33	7.45000		7.50000	7.50000	7.50000		7.55000	ns	1,2
	10	166.67	5.94994		5.99994	6.00000	6.00006		6.05006	ns	1,2
	0	200.00	4.95000		5.00000	5.00000	5.00000		5.05000	ns	1,2
	6	266.67	3.69998		3.74998	3.75000	3.75002		3.80002	ns	1,2
	10	333.33	2.94997		2.99997	3.00000	3.00003		3.05003	ns	1,2
0	400.00	2.45000		2.50000	2.50000	2.50000		2.55000	ns	1,2	

## Clock Periods - Differential Outputs with Spread Spectrum Enabled

SSC ON -0.5% Down Spread	Synthesis Error (ppm)	Center Freq. MHz	Measurement Window							Units	Notes
			1 Clock	1us	0.1s	0.1s	0.1s	1us	1 Clock		
			-c2c jitter AbsPer Min	-SSC Short-Term Average Min	- ppm Long-Term Average Min	0 ppm Period Nominal	+ ppm Long-Term Average Max	+SSC Short- Term Average Max	+c2c jitter AbsPer Max		
DIF	96	99.75	9.94906	9.99906	10.02406	10.02506	10.02603	10.05103	10.10103	ns	1,2
	19	124.69	7.94925	7.99925	8.01925	8.02005	8.02020	8.04020	8.09020	ns	1,2
	96	133.00	7.44930	7.49930	7.51805	7.51880	7.51952	7.53827	7.58827	ns	1,2
	10	166.25	5.94943	5.99943	6.01443	6.01504	6.01510	6.03010	6.08010	ns	1,2
	96	199.50	4.94953	4.99953	5.01203	5.01253	5.01301	5.02551	5.07551	ns	1,2
	-98	266.00	3.69965	3.74965	3.75902	3.75940	3.75903	3.76841	3.81841	ns	1,2
	10	332.50	2.94972	2.99972	3.00722	3.00752	3.00755	3.01505	3.06505	ns	1,2
	96	399.00	2.44977	2.49977	2.50602	2.50627	2.50651	2.51276	2.56276	ns	1,2

<sup>1</sup>Guaranteed by design and characterization, not 100% tested in production.<sup>2</sup>All ppm specifications are guaranteed with the assumption that the REF output is tuned to the exact target XTAL frequency.

## Differential Clock Tolerances, x1 = 14.31818MHz

## Clock Periods - Differential Outputs with Spread Spectrum Disabled

SSC OFF or SSC +/- 0.25% Center Spread	Synthesis Error (ppm)	Center Freq. MHz	Measurement Window							Units	Notes
			1 Clock	1us	0.1s	0.1s	0.1s	1us	1 Clock		
			-c2c jitter AbsPer Min	-SSC Short-Term Average Min	- ppm Long-Term Average Min	0 ppm Period Nominal	+ ppm Long-Term Average Max	+SSC Short- Term Average Max	+c2c jitter AbsPer Max		
DIF	35	100.00	9.94965		9.99965	10.00000	10.00035		10.05035	ns	1,2
	-114	125.00	7.95091		8.00091	8.00000	7.99909		8.04909	ns	1,2
	35	133.33	7.44974		7.49974	7.50000	7.50026		7.55026	ns	1,2
	-104	166.67	5.95062		6.00062	6.00000	5.99937		6.04937	ns	1,2
	35	200.00	4.94983		4.99983	5.00000	5.00018		5.05018	ns	1,2
	42	266.67	3.69984		3.74984	3.75000	3.75016		3.80016	ns	1,2
	-104	333.33	2.95031		3.00031	3.00000	2.99969		3.04969	ns	1,2
	35	400.00	2.44991		2.49991	2.50000	2.50009		2.55009	ns	1,2

## Clock Periods - Differential Outputs with Spread Spectrum Enabled

SSC ON -0.5% Down Spread	Synthesis Error (ppm)	Center Freq. MHz	Measurement Window							Units	Notes
			1 Clock	1us	0.1s	0.1s	0.1s	1us	1 Clock		
			-c2c jitter AbsPer Min	-SSC Short-Term Average Min	- ppm Long-Term Average Min	0 ppm Period Nominal	+ ppm Long-Term Average Max	+SSC Short- Term Average Max	+c2c jitter AbsPer Max		
DIF	199	99.75	9.94906	9.99906	10.02406	10.02506	10.02706	10.05206	10.10206	ns	1,2
	-100	124.69	7.94925	7.99925	8.01925	8.02005	8.01925	8.03925	8.08925	ns	1,2
	199	133.00	7.44930	7.49930	7.51805	7.51880	7.52029	7.53904	7.58904	ns	1,2
	10	166.25	5.94943	5.99943	6.01443	6.01504	6.01510	6.03010	6.08010	ns	1,2
	199	199.50	4.94953	4.99953	5.01203	5.01253	5.01353	5.02603	5.07603	ns	1,2
	-140	266.00	3.69965	3.74965	3.75902	3.75940	3.75887	3.76825	3.81825	ns	1,2
	10	332.50	2.94972	2.99972	3.00722	3.00752	3.00755	3.01505	3.06505	ns	1,2
	199	399.00	2.44977	2.49977	2.50602	2.50627	2.50676	2.51301	2.56301	ns	1,2

<sup>1</sup>Guaranteed by design and characterization, not 100% tested in production.<sup>2</sup>All ppm specifications are guaranteed with the assumption that the REF output is tuned to the exact target XTAL frequency.

## General SMBus serial interface information for the 9FG430

### How to Write:

- Controller (host) sends a start bit.
- Controller (host) sends the write address  $DC_{(H)}$
- IDT clock will **acknowledge**
- Controller (host) sends the beginning byte location = N
- IDT clock will **acknowledge**
- Controller (host) sends the data byte count = X
- IDT clock will **acknowledge**
- Controller (host) starts sending **Byte N through Byte N + X - 1**  
(see Note 2)
- IDT clock will **acknowledge** each byte **one at a time**
- Controller (host) sends a Stop bit

### How to Read:

- Controller (host) will send start bit.
- Controller (host) sends the write address  $DC_{(H)}$
- IDT clock will **acknowledge**
- Controller (host) sends the beginning byte location = N
- IDT clock will **acknowledge**
- Controller (host) will send a separate start bit.
- Controller (host) sends the read address  $DD_{(H)}$
- IDT clock will **acknowledge**
- IDT clock will send the data byte count = X
- IDT clock sends **Byte N + X - 1**
- IDT clock sends **Byte 0 through byte X (if  $X_{(H)}$  was written to byte 8)**.
- Controller (host) will need to acknowledge each byte
- Controller (host) will send a not acknowledge bit
- Controller (host) will send a stop bit

Index Block Write Operation		
Controller (Host)		IDT (Slave/Receiver)
T	starT bit	
Slave Address $DC_{(H)}$		
WR	WRite	
		ACK
Beginning Byte = N		
		ACK
Data Byte Count = X		
		ACK
Beginning Byte N	X Byte	
○		ACK
○		○
○		○
Byte N + X - 1		○
		ACK
P	stoP bit	

Index Block Read Operation		
Controller (Host)		IDT (Slave/Receiver)
T	starT bit	
Slave Address $DC_{(H)}$		
WR	WRite	
		ACK
Beginning Byte = N		
		ACK
RT	Repeat starT	
Slave Address $DD_{(H)}$		
RD	ReaD	
		ACK
		Data Byte Count = X
ACK		
ACK		Beginning Byte N
○		○
○		○
○		○
		Byte N + X - 1
N	Not acknowledge	
P	stoP bit	

**SMBus Table: Device Control Register, READ/WRITE ADDRESS (DC/DD)**

Byte 0	Pin #	Name	Control Function	Type	0	1	Default
Bit 7	17		FS3 <sup>1</sup>	RW	See Frequency Selection Table, Page 1		Pin 17
Bit 6	6		FS2 <sup>1</sup>	RW			Pin 6
Bit 5	24		FS1 <sup>1</sup>	RW			Pin 24
Bit 4	25		FS0 <sup>1</sup>	RW			Pin 25
Bit 3	16		Spread Enable <sup>1</sup>	RW	Off	On	Pin 16
Bit 2	-	Enable Software Control of Frequency, Spread Enable (Spread Type always Software Control)		RW	Hardware Select	Software Select	0
Bit 1			DIF_STOP# drive mode	RW	Driven	Hi-Z	0
Bit 0			SPREAD TYPE	RW	Down	Center	0

**Notes:**

1. These bits reflect the state of the corresponding pins at power up, but may be written to if Byte 0, bit 2 is set to '1'. FS3 is the SEL14M\_25M# pin.

**SMBus Table: Output Enable Register**

Byte 1	Pin #	Name	Control Function	Type	0	1	Default
Bit 7	-	Reserved					1
Bit 6	-	DIF_3 EN	Output Enable	RW	Disable	Enable	1
Bit 5	-	DIF_2 EN	Output Enable	RW	Disable	Enable	1
Bit 4	-	Reserved					1
Bit 3	-	Reserved					1
Bit 2	-	DIF_1 EN	Output Enable	RW	Disable	Enable	1
Bit 1	-	DIF_0 EN	Output Enable	RW	Disable	Enable	1
Bit 0	-	Reserved					1

**SMBus Table: Output Stop Control Register**

Byte 2	Pin #	Name	Control Function	Type	0	1	Default
Bit 7	-	Reserved					0
Bit 6	-	DIF_3 STOP EN	Free Run/ Stop Enable	RW	Free-run	Stop-able	0
Bit 5	-	DIF_2 STOP EN	Free Run/ Stop Enable	RW	Free-run	Stop-able	0
Bit 4	-	Reserved					0
Bit 3	-	Reserved					0
Bit 2	-	DIF_1 STOP EN	Free Run/ Stop Enable	RW	Free-run	Stop-able	0
Bit 1	-	DIF_0 STOP EN	Free Run/ Stop Enable	RW	Free-run	Stop-able	0
Bit 0	-	Reserved					0

**SMBus Table: Frequency Select Readback Register**

Byte 3	Pin #	Name	Control Function	Type	0	1	Default
Bit 7	27	SEL14M_25M# <sup>1</sup> (FS3)	State of pin 17	R	See Frequency Selection Table, Page 1		Pin 17
Bit 6	6	FS2 <sup>1</sup>	State of pin 6	R			Pin 6
Bit 5	44	FS1 <sup>1</sup>	State of pin 24	R			Pin 24
Bit 4	45	FS0 <sup>1</sup>	State of pin 25	R			Pin 25
Bit 3	16	SPREAD <sup>1</sup>	State of pin 26	R	Off	On	Pin 16
Bit 2			Reserved				0
Bit 1			Reserved				0
Bit 0			Reserved				0

**Notes:**

1. These bits reflect the state of the corresponding pins, regardless of whether software programming is enabled or not.

**SMBus Table: Vendor & Revision ID Register**

Byte 4	Pin #	Name	Control Function	Type	0	1	Default
Bit 7	-	RID3	REVISION ID	R	-	-	0
Bit 6	-	RID2		R	-	-	0
Bit 5	-	RID1		R	-	-	0
Bit 4	-	RID0		R	-	-	0
Bit 3	-	VID3	VENDOR ID	R	-	-	0
Bit 2	-	VID2		R	-	-	0
Bit 1	-	VID1		R	-	-	0
Bit 0	-	VID0		R	-	-	1

**SMBus Table: DEVICE ID**

Byte 5	Pin #	Name	Control Function	Type	0	1	Default
Bit 7	-	DID7	Device ID = 01 hex	R	-	-	0
Bit 6	-	DID6		R	-	-	0
Bit 5	-	DID5		R	-	-	0
Bit 4	-	DID4		R	-	-	0
Bit 3	-	DID3		R	-	-	0
Bit 2	-	DID2		R	-	-	0
Bit 1	-	DID1		R	-	-	0
Bit 0	-	DID0		R	-	-	1

**SMBus Table: Byte Count Register**

Byte 6	Pin #	Name	Control Function	Type	0	1	Default
Bit 7	-	BC7	Writing to this register will configure how many bytes will be read back, default is 07 = 7 bytes.	RW	-	-	0
Bit 6	-	BC6		RW	-	-	0
Bit 5	-	BC5		RW	-	-	0
Bit 4	-	BC4		RW	-	-	0
Bit 3	-	BC3		RW	-	-	0
Bit 2	-	BC2		RW	-	-	1
Bit 1	-	BC1		RW	-	-	1
Bit 0	-	BC0		RW	-	-	1

**SMBus Table: Reserved Register**

Byte 7	Pin #	Name	Control Function	Type	0	1	Default
Bit 7	-		Reserved				0
Bit 6	-		Reserved				0
Bit 5	-		Reserved				0
Bit 4	-		Reserved				0
Bit 3	-		Reserved				0
Bit 2	-		Reserved				0
Bit 1	-		Reserved				0
Bit 0	-		Reserved				0

**SMBus Table: Reserved Register**

Byte 8	Pin #	Name	Control Function	Type	0	1	Default
Bit 7	-		Reserved				0
Bit 6	-		Reserved				0
Bit 5	-		Reserved				0
Bit 4	-		Reserved				0
Bit 3	-		Reserved				0
Bit 2	-		Reserved				0
Bit 1	-		Reserved				0
Bit 0	-		Reserved				0

**SMBus Table: M/N Programming Enable**

Byte 9	Pin #	Name	Control Function	Type	0	1	Default
Bit 7	-	M/N_Enable	M/N Prog. Enable	RW	Disable	Enable	0
Bit 6	-		Reserved				1
Bit 5	5	REFOUT_En	REFOUT Enable	RW	Disable	Enable	1
Bit 4	-		Reserved				0
Bit 3	-		Reserved				0
Bit 2	-		Reserved				0
Bit 1	-		Reserved				0
Bit 0	-		Reserved				0

**SMBus Table: PLL Frequency Control Register**

Byte 10	Pin #	Name	Control Function	Type	0	1	Default
Bit 7	-	PLL N Div8	N Divider Prog bit 8	RW	The decimal representation of M and N Divider in Byte 10 and 11 will configure the PLL VCO frequency. Default at power up = latch-in or Byte 0 Rom table. VCO Frequency = $f_{XTAL} \times [N_{Div}(9:0)+8] / [M_{Div}(5:0)+2]$ . The user does NOT need to program these registers for standard frequencies.		X
Bit 6	-	PLL N Div9	N Divider Prog bit 9	RW			X
Bit 5	-	PLL M Div5	M Divider Programming bit (5:0)	RW			X
Bit 4	-	PLL M Div4		RW			X
Bit 3	-	PLL M Div3		RW			X
Bit 2	-	PLL M Div2		RW			X
Bit 1	-	PLL M Div1		RW			X
Bit 0	-	PLL M Div0		RW			X

**SMBus Table: PLL Frequency Control Register**

Byte 11	Pin #	Name	Control Function	Type	0	1	Default
Bit 7	-	PLL N Div7	N Divider Programming Byte11 bit(7:0) and Byte10 bit(7:6)	RW	The decimal representation of M and N Divider in Byte 10 and 11 will configure the PLL VCO frequency. Default at power up = latch-in or Byte 0 Rom table. VCO Frequency = fXTAL x [NDiv(9:0)+8] / [MDiv(5:0)+2]. The user does NOT need to program these resgisters for standard frequencies.		X
Bit 6	-	PLL N Div6		RW			X
Bit 5	-	PLL N Div5		RW			X
Bit 4	-	PLL N Div4		RW			X
Bit 3	-	PLL N Div3		RW			X
Bit 2	-	PLL N Div2		RW			X
Bit 1	-	PLL N Div1		RW			X
Bit 0	-	PLL N Div0		RW			X

**SMBus Table: PLL Spread Spectrum Control Register**

Byte 12	Pin #	Name	Control Function	Type	0	1	Default
Bit 7	-	PLL SSP7	Spread Spectrum Programming bit(7:0)	RW	These Spread Spectrum bits in Byte 12 and 13 will program the spread percentage of PLL. The user does not need to modify these settings unless non- standard spread amounts are required. The part defaults to - 0.5% spread when spread is enabled.		X
Bit 6	-	PLL SSP6		RW			X
Bit 5	-	PLL SSP5		RW			X
Bit 4	-	PLL SSP4		RW			X
Bit 3	-	PLL SSP3		RW			X
Bit 2	-	PLL SSP2		RW			X
Bit 1	-	PLL SSP1		RW			X
Bit 0	-	PLL SSP0		RW			X

**SMBus Table: PLL Spread Spectrum Control Register**

Byte 13	Pin #	Name	Control Function	Type	0	1	Default
Bit 7	-		Reserved				0
Bit 6	-	PLL SSP14	Spread Spectrum Programming bit(14:8)	RW	These Spread Spectrum bits in Byte 12 and 13 will program the spread percentage of PLL. The user does not need to modify these settings unless non- standard spread amounts are required. The part defaults to - 0.5% spread when spread is enabled.		X
Bit 5	-	PLL SSP13		RW			X
Bit 4	-	PLL SSP12		RW			X
Bit 3	-	PLL SSP11		RW			X
Bit 2	-	PLL SSP10		RW			X
Bit 1	-	PLL SSP9		RW			X
Bit 0	-	PLL SSP8		RW			X

### 28-Pin SSOP Package Drawing and Dimensions

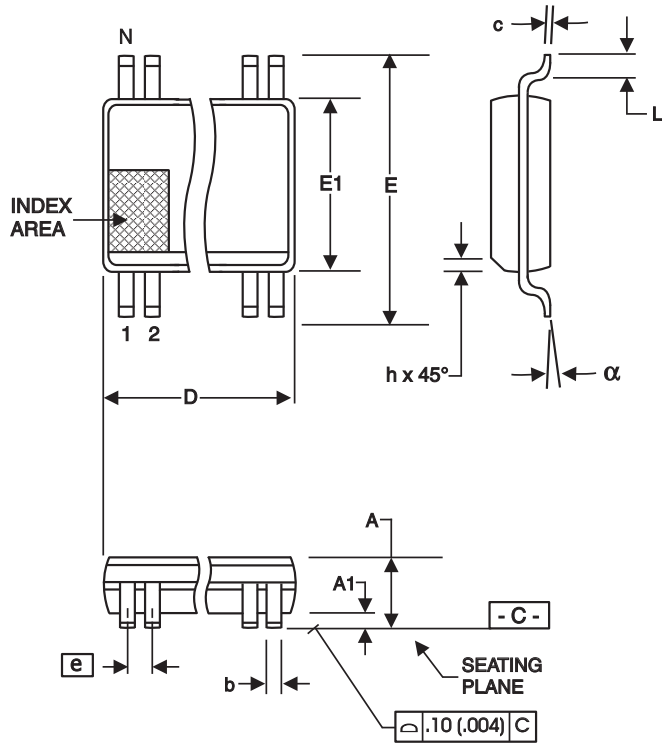

209 mil SSOP

SYMBOL	In Millimeters COMMON DIMENSIONS		In Inches COMMON DIMENSIONS	
	MIN	MAX	MIN	MAX
A	--	2.00	--	.079
A1	0.05	--	.002	--
A2	1.65	1.85	.065	.073
b	0.22	0.38	.009	.015
c	0.09	0.25	.0035	.010
D	SEE VARIATIONS		SEE VARIATIONS	
E	7.40	8.20	.291	.323
E1	5.00	5.60	.197	.220
e	0.65 BASIC		0.0256 BASIC	
L	0.55	0.95	.022	.037
N	SEE VARIATIONS		SEE VARIATIONS	
$\alpha$	0°	8°	0°	8°

VARIATIONS

N	D mm.		D (inch)	
	MIN	MAX	MIN	MAX
28	9.90	10.50	.390	.413

Reference Doc.: JEDEC Publication 95, MO-150

10-0033

## 28-Pin TSSOP Package Drawing and Dimensions

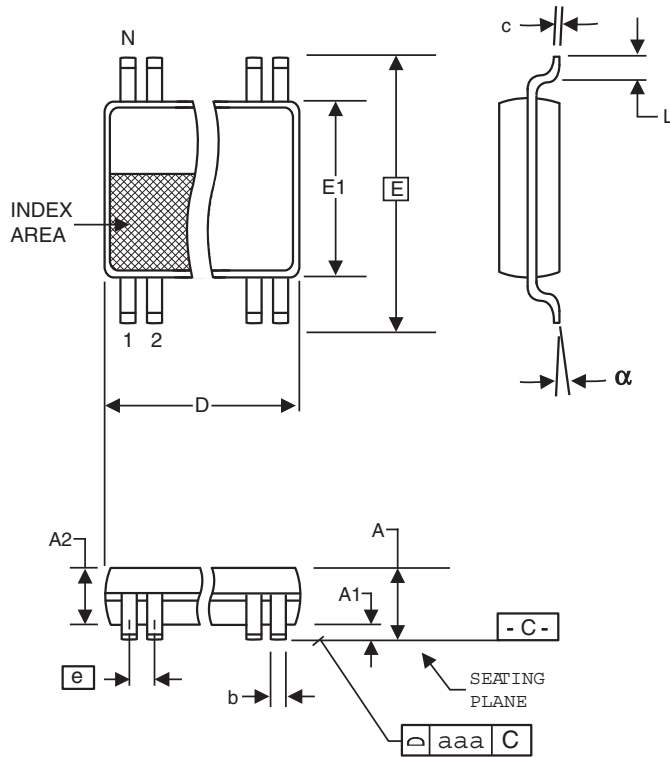

4.40 mm. Body, 0.65 mm. Pitch TSSOP

(173 mil) (25.6 mil)

SYMBOL	In Millimeters		In Inches	
	COMMON DIMENSIONS		COMMON DIMENSIONS	
	MIN	MAX	MIN	MAX
A	--	1.20	--	.047
A1	0.05	0.15	.002	.006
A2	0.80	1.05	.032	.041
b	0.19	0.30	.007	.012
c	0.09	0.20	.0035	.008
D	SEE VARIATIONS		SEE VARIATIONS	
E	6.40 BASIC		0.252 BASIC	
E1	4.30	4.50	.169	.177
e	0.65 BASIC		0.0256 BASIC	
L	0.45	0.75	.018	.030
N	SEE VARIATIONS		SEE VARIATIONS	
$\alpha$	0°	8°	0°	8°
aaa	--	0.10	--	.004

## VARIATIONS

N	D mm.		D (inch)	
	MIN	MAX	MIN	MAX
28	9.60	9.80	.378	.386

Reference Doc.: JEDEC Publication 95, MO-153

10-0035

## Ordering Information

Part / Order Number	Shipping Packaging	Package	Temperature
9FG430AFLF	Tubes	28-pin SSOP	0 to +70°C
9FG430AFLFT	Tape and Reel	28-pin SSOP	0 to +70°C
9FG430AFILF	Tubes	28-pin SSOP	-40 to +85°C
9FG430AFILFT	Tape and Reel	28-pin SSOP	-40 to +85°C
9FG430AGLF	Tubes	28-pin TSSOP	0 to +70°C
9FG430AGLFT	Tape and Reel	28-pin TSSOP	0 to +70°C
9FG430AGILF	Tubes	28-pin TSSOP	-40 to +85°C
9FG430AGILFT	Tape and Reel	28-pin TSSOP	-40 to +85°C

“LF” suffix to the part number are the Pb-Free configuration and are RoHS compliant.

“A” is the device revision designator (will not correlate with the datasheet revision).

**Revision History**

<b>Rev.</b>	<b>Issue Date</b>	<b>Who</b>	<b>Description</b>	<b>Page #</b>
0.1	7/13/2010	RDW	New datasheet.	
A	7/13/2010	RDW	Release	
B	7/20/2010	RDW	1. Added PPM tables to DS for both 25M and 14.318M inputs 2. Added Test load figures	
C	8/25/2010	RDW	1. Updated/reformatted Electrical Tables 2. Corrected Features/Benefits and General Description 3. Updated pull up ^ and pull down v indicators. 4. Updated termination figures to include Fig. 5 for REF output, merged test load figures into these figures.	1, Various
D	4/4/2017	RDW	1. Corrected Byte 5 Device ID from 43 hex to 01 hex	13

---

## IMPORTANT NOTICE AND DISCLAIMER

RENESAS ELECTRONICS CORPORATION AND ITS SUBSIDIARIES (“RENESAS”) PROVIDES TECHNICAL SPECIFICATIONS AND RELIABILITY DATA (INCLUDING DATASHEETS), DESIGN RESOURCES (INCLUDING REFERENCE DESIGNS), APPLICATION OR OTHER DESIGN ADVICE, WEB TOOLS, SAFETY INFORMATION, AND OTHER RESOURCES “AS IS” AND WITH ALL FAULTS, AND DISCLAIMS ALL WARRANTIES, EXPRESS OR IMPLIED, INCLUDING, WITHOUT LIMITATION, ANY IMPLIED WARRANTIES OF MERCHANTABILITY, FITNESS FOR A PARTICULAR PURPOSE, OR NON-INFRINGEMENT OF THIRD-PARTY INTELLECTUAL PROPERTY RIGHTS.

These resources are intended for developers who are designing with Renesas products. You are solely responsible for (1) selecting the appropriate products for your application, (2) designing, validating, and testing your application, and (3) ensuring your application meets applicable standards, and any other safety, security, or other requirements. These resources are subject to change without notice. Renesas grants you permission to use these resources only to develop an application that uses Renesas products. Other reproduction or use of these resources is strictly prohibited. No license is granted to any other Renesas intellectual property or to any third-party intellectual property. Renesas disclaims responsibility for, and you will fully indemnify Renesas and its representatives against, any claims, damages, costs, losses, or liabilities arising from your use of these resources. Renesas' products are provided only subject to Renesas' Terms and Conditions of Sale or other applicable terms agreed to in writing. No use of any Renesas resources expands or otherwise alters any applicable warranties or warranty disclaimers for these products.

(Disclaimer Rev.1.01 Jan 2024)

### Corporate Headquarters

TOYOSU FORESIA, 3-2-24 Toyosu,  
Koto-ku, Tokyo 135-0061, Japan  
[www.renesas.com](http://www.renesas.com)

### Trademarks

Renesas and the Renesas logo are trademarks of Renesas Electronics Corporation. All trademarks and registered trademarks are the property of their respective owners.

### Contact Information

For further information on a product, technology, the most up-to-date version of a document, or your nearest sales office, please visit [www.renesas.com/contact-us/](http://www.renesas.com/contact-us/).

## Looking for pricing, stock, or lifecycle information?

Click below to explore more details on WIN SOURCE:

- ⊖ [View 9FG430AGILFT on WIN SOURCE](#)
- ⊖ [Renesas Electronics America](#) Information

## Optimize Your Supply Chain with WIN SOURCE Solutions

- ✓ Global Sourcing Solution
- ✓ Obsolete Management
- ✓ Cost Control Management
- ✓ Shortage Management
- ✓ Alternative Solution
- ✓ Excess Inventory Management