



**THE DATASHEET OF
9EPRS525AGILFT**



Recommended Application:

56-pin CK505 compatible clock, w/fully integrated Vreg and series resistors on differential outputs for embedded applications

Output Features:

- 2 - CPU differential low power push-pull pairs
- 7 - SRC differential push-pull pairs
- 1 - CPU/SRC selectable differential low power push-pull pair
- 1 - SRC/DOT selectable differential low power push-pull pair
- 1 - SRC/SE selectable differential push-pull pair/Single-ended outputs
- 5 - PCI, 33MHz
- 1 - USB, 48MHz
- 1 - REF, 14.318MHz

Key Specifications:

- CPU outputs cycle-cycle jitter < 85ps
- SRC output cycle-cycle jitter < 125ps
- PCI outputs cycle-cycle jitter < 250ps
- +/- 100ppm frequency accuracy on all outputs
- SRC outputs meet PCIe Gen2 when sourced from PLL3

Features/Benefits:

- Supports spread spectrum modulation, 0 to -0.5% down spread
- Supports CPU clks up to 400MHz
- Uses external 14.318MHz crystal, external crystal load caps are required for frequency tuning

Table 1: CPU Frequency Select Table

FS _L C ² B0b7	FS _L B ¹ B0b6	FS _L A ¹ B0b5	CPU MHz	SRC MHz	PCI MHz	REF MHz	USB MHz	DOT MHz
0	0	0	266.66	100.00	33.33	14.318	48.00	96.00
0	0	1	133.33					
0	1	0	200.00					
0	1	1	166.66					
1	0	0	333.33					
1	0	1	100.00					
1	1	0	400.00					
1	1	1	Reserved					

1. FS_LA and FS_LB are low-threshold inputs. Please see V_{IL,FS} and V_{IH,FS} specifications in the Input/Supply/Common Output Parameters Table for correct values. Also refer to the Test Clarification Table.
2. FS_LC is a three-level input. Please see the V_{IL,FS} and V_{IH,FS} specifications in the Input/Supply/Common Output Parameters Table for correct values.

Pin Configuration

PCI0/CR#_A	1	56	SCLK
VDDPCI	2	55	SDATA
PCI1/CR#_B	3	54	REF0/FSLC/TEST_SEL
PCI2/TME	4	53	VDDREF
PCI3/CFG0	5	52	X1
PCI4/SRC5_EN	6	51	X2
PCI_F5/ITP_EN	7	50	GNDREF
GNDPCI	8	49	FSLB/TEST_MODE
VDD48	9	48	CK_PWRGD/PD#
USB_48MHz/FSLA	10	47	VDDCPU
GND48	11	46	CPUT0_LRS
VDD96IO	12	45	CPUC0_LRS
DOTT_96_LRS/SRCT0_LRS	13	44	GNDCPU
DOTC_96_LRS/SRCC0_LRS	14	43	CPUT1_F_LRS
GND	15	42	CPUC1_F_LRS
VDD	16	41	VDDCPUIO
SRCT1_LRS/SE1	17	40	NC
SRCC1_LRS/SE2	18	39	CPUT2_ITP_LRS/SRCT8_LRS
GND	19	38	CPUC2_ITP_LRS/SRCC8_LRS
VDDPLL3IO	20	37	VDDSRCIO
SRCT2_LRS/SATAT_LRS	21	36	SRCT7_LRS/CR#_F
SRCC2_LRS/SATAC_LRS	22	35	SRCC7_LRS/CR#_E
GNDSRC	23	34	GNDSRC
SRCT3_LRS/CR#_C	24	33	SRCT6_LRS
SRCC3_LRS/CR#_D	25	32	SRCC6_LRS
VDDSRCIO	26	31	VDDSRC
SRCT4_LRS	27	30	PCI_STOP#/SRCT5_LRS
SRCC4_LRS	28	29	CPU_STOP#/SRCC5_LRS

56-TSSOP

Pin Description

PIN #	PIN NAME	TYPE	DESCRIPTION
1	PCI0/CR#_A	I/O	3.3V PCI clock output or Clock Request control A for either SRC0 or SRC2 pair The power-up default is PCI0 output, but this pin may also be used as a Clock Request control of SRC pair 0 or SRC pair 2 via SMBus. Before configuring this pin as a Clock Request Pin, the PCI output must first be disabled in byte 2, bit 0 of SMBus address space. After the PCI output is disabled (high-Z), the pin can then be set to serve as a Clock Request pin for either SRC pair 2 or pair 0 using the CRA#_EN bit located in byte 5 of SMBus address space. Byte 5, bit 7 0 = PCI0 enabled (default) 1 = CRA# enabled. Byte 5, bit 6 controls whether CRA# controls SRC0 or SRC2 pair Byte 5, bit 6 0 = CRA# controls SRC0 pair (default), 1 = CRA# controls SRC2 pair
2	VDDPCI	PWR	Power supply for PCI clocks, nominal 3.3V
3	PCI1/CR#_B	I/O	3.3V PCI clock output/Clock Request control B for either SRC1 or SRC4 pair The power-up default is PCI1 output, but this pin may also be used as a Clock Request control of SRC pair 1 or SRC pair 4 via SMBus. Before configuring this pin as a Clock Request Pin, the PCI output must first be disabled in byte 2, bit 1 of SMBus address space. After the PCI output is disabled (high-Z), the pin can then be set to serve as a Clock Request pin for either SRC pair 1 or pair 4 using the CRB#_EN bit located in byte 5 of SMBus address space. Byte 5, bit 5 0 = PCI1 enabled (default) 1 = CRB# enabled. Byte 5, bit 6 controls whether CRB# controls SRC1 or SRC4 pair Byte 5, bit 4 0 = CRB# controls SRC1 pair (default) 1 = CRB# controls SRC4 pair
4	PCI2/TME	I/O	3.3V PCI clock output / Trusted Mode Enable(TME) Latched Input. This pin is sampled on power-up as follows 0=Overclocking of CPU and SRC allowed 1=Overclocking of CPU and SRC NOT allowed After being sampled on power-up, this pin becomes a 3.3V PCI Output
5	PCI3/CFG0	I/O	3.3V PCI clock output/Configuration Strap. See PCI3 Configuration Table for more information
6	PCI4/SRC5_EN	I/O	3.3V PCI clock output / SRC5 pair or PCI_STOP#/CPU_STOP# enable strap. On powerup, the logic value on this pin determines if the SRC5 pair is enabled or if CPU_STOP#/PCI_STOP# is enabled (pins 29 and 30). The latched value controls the pin function on pins 29 and 30 as follows 0 = PCI_STOP#/CPU_STOP# 1 = SRC5/SRC5#
7	PCI_F5/ITP_EN	I/O	Free running PCI clock output and ITP/SRC8 enable strap. This output is not affected by the state of the PCI_STOP# pin. On powerup, the state of this pin determines whether pins 38 and 39 are an ITP or SRC pair. 0 =SRC8/SRC8# 1 = ITP/ITP#
8	GNDPCI	PWR	Ground pin for the PCI outputs
9	VDD48	PWR	Power pin for the 48MHz output and PLL.3.3V
10	USB_48MHz/FSLA	I/O	3.3V tolerant input for CPU frequency selection. Refer to input electrical characteristics for V _{il} _FS and V _{ih} _FS values. / Fixed 48MHz USB clock output. 3.3V.
11	GND48	PWR	Ground pin for the 48MHz outputs
12	VDD96IO	PWR	Power supply for DOT96 outputs, 1.05V to 3.3V.
13	DOTT_96_LRS/SRCT0_LRS	OUT	True clock of low power differential SRC or DOT96 with integrated 33 ohm Rs. The power-up default function is SRC0. After powerup, this pin function may be changed to DOT96 via SMBus Byte 1, bit 7 as follows: 0= SRC0 1=DOT96
14	DOTC_96_LRS/SRCC0_LRS	OUT	Complement clock of low power differential SRC or DOT96 with integrated 33 ohm Rs. The power-up default function is SRC0#. After powerup, this pin function may be changed to DOT96# via SMBus Byte 1, bit 7 as follows 0= SRC0# 1=DOT96#
15	GND	PWR	Ground pin.
16	VDD	PWR	Power supply, nominal 3.3V
17	SRCT1_LRS/SE1	OUT	True clock of low power differential SRC1 clock pair with integrated 33 ohm Rs. / 3.3V single-ended output. The powerup default is 100 MHz SRC, -0.5% downspread. The pin function may be changed via SMBus B1b[4:1]
18	SRCC1_LRS/SE2	OUT	Complement clock of low power differential SRC1 clock pair with integrated 33 ohm Rs / 3.3V single-ended output. The powerup default is 100 MHz SRC, -0.5% downspread. The pin function may be changed via SMBus B1b[4:1]
19	GND	PWR	Ground pin.
20	VDDPLL3IO	PWR	Power supply for PLL3 outputs. 1.05V to 3.3V.
21	SRCT2_LRS/SATAT_LRS	OUT	True clock of low power differential SRC/SATA clock pair with integrated Rs.
22	SRCC2_LRS/SATAC_LRS	OUT	Complement clock of low power differential push-pull SRC/SATA clock pair with integrated 33 ohm Rs.
23	GNDSRC	PWR	Ground pin for the SRC outputs
24	SRCT3_LRS/CR#_C	I/O	True clock of low power differential SRC clock pair with integrated 33 ohm Rs./ Clock Request control C for either SRC0 or SRC2 pair. The power-up default is SRCCLK3 output, but this pin may also be used as a Clock Request control of SRC pair 0 or SRC pair 2 via SMBus. Before configuring this pin as a Clock Request Pin, the SRC output must first be disabled in byte 4, bit 7 of SMBus address space. After the SRC output is disabled, the pin can then be set to serve as a Clock Request pin for either SRC pair 2 or pair 0 using the CRC#_EN bit located in byte 5 of SMBus address space. Byte 5, bit 3 0 = SRCCLK3 enabled (default) 1 = CRC# enabled. Byte 5, bit 2 controls whether CRC# controls SRC0 or SRC2 pair Byte 5, bit 2 0 = CRC# controls SRC0 pair (default), 1 = CRC# controls SRC2 pair

Pin Description (continued)

PIN #	PIN NAME	TYPE	DESCRIPTION
25	SRCC3_LRS/CR#_D	I/O	Complementary clock of low power differential SRC clock pair with integrated 33 ohm Rs/ Clock Request control D for either SRC1 or SRC4 pair. The power-up default is SRCLK3 output, but this pin may also be used as a Clock Request control of SRC pair 1 or SRC pair 4 via SMBus. Before configuring this pin as a Clock Request Pin, the SRC output must first be disabled in byte 4, bit 7 of SMBus address space. After the SRC output is disabled, the pin can then be set to serve as a Clock Request pin for either SRC pair 1 or pair 4 using the CRD#_EN bit located in byte 5 of SMBus address space. Byte 5, bit 1 0 = SRC3 enabled (default) 1 = CRD# enabled. Byte 5, bit 0 controls whether CRD# controls SRC1 or SRC4 pair Byte 5, bit 0 0 = CRD# controls SRC1 pair (default), 1 = CRD# controls SRC4 pair
26	VDDSRCIO	PWR	Power supply for SRC outputs. 1.05V to 3.3V.
27	SRCT4_LRS	OUT	True clock of low power differential SRC clock pair with integrated 33 ohm Rs.
28	SRCC4_LRS	OUT	Complement clock of low power differential SRC clock pair with 33 ohm integrated Rs.
29	CPU_STOP#/SRCC5_LRS	I/O	Stops all CPUCLK, except those set to be free running clocks / Complement clock of low power differential SRC pair with 33 ohm integrated Rs.
30	PCL_STOP#/SRCT5_LRS	I/O	Stops all PCICLKs at logic 0 level, when low. Free running PCICLKs are not effected by this input. / True clock of low power differential SRC pair with integrated 33 ohm Rs.
31	VDDSRC	PWR	Supply for SRC PLL, 3.3V nominal
32	SRCC6_LRS	OUT	Complement clock of low power differential SRC clock pair with 33 ohm integrated Rs.
33	SRCT6_LRS	OUT	True clock of low power differential SRC clock pair with integrated 33 ohm Rs.
34	GNDSRC	PWR	Ground pin for the SRC outputs
35	SRCC7_LRS/CR#_E	I/O	Complement clock of differential push-pull SRC clock pair with 33 ohm integrated Rs. / Clock Request control E for SRC6 pair. The power-up default is SRC7#, but this pin may also be used as a Clock Request control of SRC6 via SMBus. Before configuring this pin as a Clock Request Pin, the SRC7 output pair must first be disabled in byte 3, bit 3 of SMBus configuration space. After the SRC output is disabled (high-Z), the pin can then be set to serve as a Clock Request for SRC6 pair using byte 6, bit 7 of SMBus configuration space Byte 6, bit 7 0 = SRC7# enabled (default) 1 = CRE# enabled
36	SRCT7_LRS/CR#_F	I/O	True clock of differential push-pull SRC clock pair/ Clock Request control 8 for SRC8 pair The power-up default is SRC7, but this pin may also be used as a Clock Request control of SRC8 via SMBus. Before configuring this pin as a Clock Request Pin, the SRC7 output pair must first be disabled in byte 3, bit 3 of SMBus configuration space. After the SRC output is disabled (high-Z), the pin can then be set to serve as a Clock Request for SRC8 pair using byte 6, bit 7 of SMBus configuration space
37	VDDSRCIO	PWR	Power supply for SRC outputs. 1.05V to 3.3V.
38	CPUC2_ITP_LRS/SRCC8_LRS	OUT	Complement clock of low power differential CPU2/Complement clock of differential SRC pair. 33 ohm Rs is integrated. The function of this pin is determined by the latched input value on pin 7, PCIF5/ITP_EN on powerup. The function is as follows: Pin 7 latched input Value 0 = SRC8# 1 = ITP#
39	CPUT2_ITP_LRS/SRCT8_LRS	OUT	True clock of low power differential CPU2/True clock of differential SRC pair. 33 ohm Rs is integrated. The function of this pin is determined by the latched input value on pin 7, PCIF5/ITP_EN on powerup. The function is as follows: Pin 7 latched input Value 0 = SRC8 1 = ITP
40	NC	N/A	No Connect
41	VDDCPUIO	PWR	Power supply for CPU outputs, 1.05V to 3.3V.
42	CPUC1_F_LRS	OUT	Complementary clock of low power differential push-pull CPU output with integrated 33 ohm Rs. This CPU clock is free running during iAMT.
43	CPUT1_F_LRS	OUT	True clock of differential push-pull CPU clock pair with integrated 33 ohm Rs. This clock is free running during iAMT.
44	GNDCPU	PWR	Ground pin for the CPU outputs
45	CPUC0_LRS	OUT	Complement clock of low power differential CPU clock pair with integrated 33 ohm Rs.
46	CPUT0_LRS	OUT	True clock of low power differential CPU clock pair with integrated 33 ohm Rs.
47	VDDCPU	PWR	Supply for CPU PLL, 3.3V nominal
48	CK_PWRGD/PD#	IN	Notifies CK505 to sample latched inputs, or iAMT entry/exit, or PWRDWN# mode
49	FSLB/TEST_MODE	IN	3.3V tolerant input for CPU frequency selection. Refer to input electrical characteristics for Vil_FS and Vih_FS values. TEST_MODE is a real time input to select between Hi-Z and REF/N divider mode while in test mode. Refer to Test Clarification Table.
50	GNDREF	PWR	Ground pin for the REF outputs.
51	X2	OUT	Crystal output, Nominally 14.318MHz
52	X1	IN	Crystal input, Nominally 14.318MHz.
53	VDDREF	PWR	Ref. XTAL power supply, nominal 3.3V
54	REF0/FSLC/TEST_SEL	I/O	14.318 MHz reference clock./ 3.3V tolerant input for CPU frequency selection. Refer to input electrical characteristics for Vil_FS and Vih_FS values. /TEST_Sel: 3-level latched input to enable test mode. Refer to Test Clarification Table
55	SDATA	I/O	Data pin for SMBus circuitry, 5V tolerant.
56	SCLK	IN	Clock pin of SMBus circuitry, 5V tolerant.

General Description

ICS9EPRS525 is compliant Intel CK505 Yellow Cover specification. This clock synthesizer provides a single chip solution for Intel desktop chipsets. ICS9EPRS525 is driven with a 14.318MHz crystal. It also provides a tight ppm accuracy output for Serial ATA and PCI-Express support.

Block Diagram

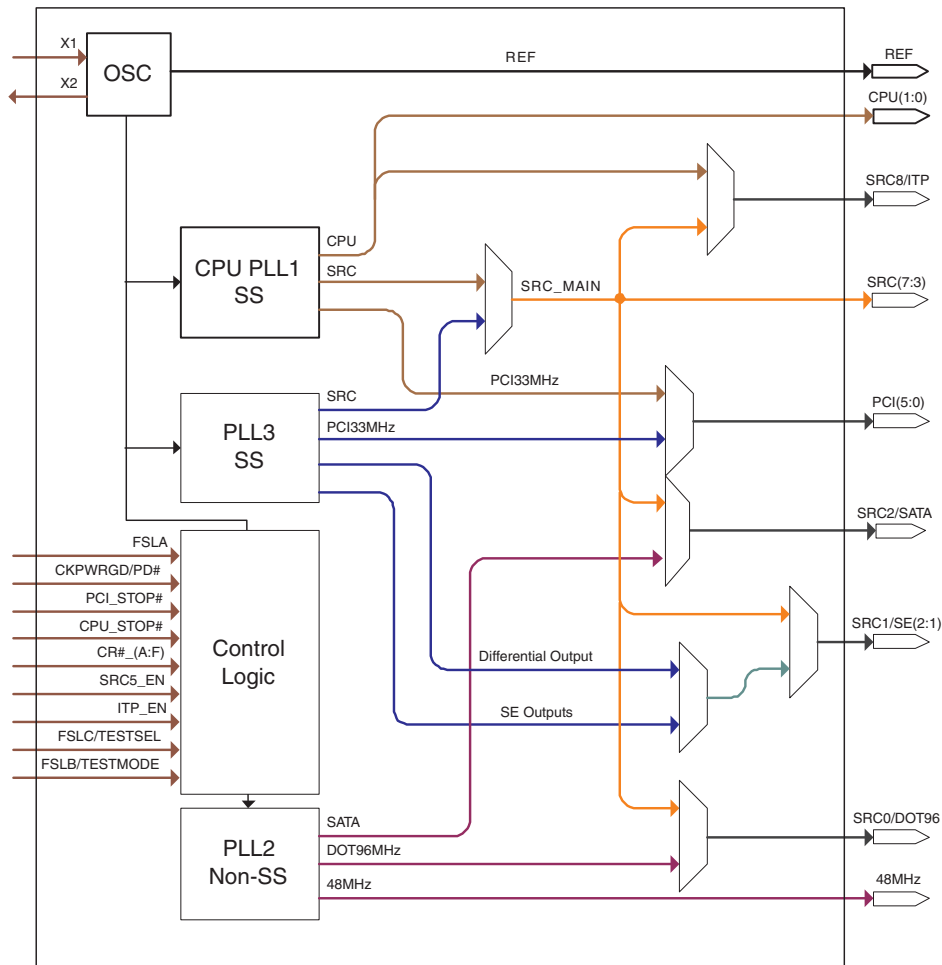

Power Groups

Pin Number		Description
VDD	GND	
41, 47	44	CPUCLK
16	15	Master Clock, Analog
26, 31, 37	23, 34	SRCCLK
20	19	PLL3/SE
12	11	DOT 96Mhz
9	11	USB 48
53	50	Xtal, REF
2	8	PCICLK

Absolute Maximum Ratings - DC Parameters

PARAMETER	SYMBOL	CONDITIONS	MIN	MAX	UNITS	Notes
Maximum Supply Voltage	VDDxxx	Supply Voltage		4.6	V	7
Maximum Supply Voltage	VDDxxx_IO	Low-Voltage Differential I/O Supply		3.8	V	7
Maximum Input Voltage	V _{IH}	3.3V Inputs		4.6	V	4,5,7
Minimum Input Voltage	V _{IL}	Any Input	GND - 0.5		V	4,7
Storage Temperature	T _s	-	-65	150	°C	4,7
Input ESD protection	ESD prot	Human Body Model	2000		V	6,7

¹Guaranteed by design and characterization, not 100% tested in production.

²Operation under these conditions is neither implied, nor guaranteed.

³Maximum input voltage is not to exceed VDD

Electrical Characteristics - Input/Supply/Common Output DC Parameters

PARAMETER	SYMBOL	CONDITIONS	MIN	MAX	UNITS	Notes
Ambient Operating Temp	T _{ambient}	-	0	70	°C	
Supply Voltage	VDDxxx	Supply Voltage	3.135	3.465	V	
Supply Voltage	VDDxxx_IO	Low-Voltage Differential I/O Supply	0.9975	3.465	V	10
Input High Voltage	V _{IHSE}	Single-ended 3.3V inputs	2	V _{DD} + 0.3	V	3
Input Low Voltage	V _{ILSE}	Single-ended 3.3V inputs	V _{SS} - 0.3	0.8	V	3
Low Threshold Input- High Voltage	V _{IH_FS_TEST}	3.3 V +/-5%	2	VDD + 0.3	V	8
Low Threshold Input- FSC = '1' Voltage	V _{IH_FS_FSC}	3.3 V +/-5%	0.7	1.5	V	8
Low Threshold Input- FSA,FSB = '1' Voltage	V _{IH_FS_FSAB}	3.3 V +/-5%	0.7	VDD+0.3	V	
Low Threshold Input-Low Voltage	V _{IL_FS}	3.3 V +/-5%	V _{SS} - 0.3	0.35	V	
PCI3/CFG0 Input	V _{IL_CFGHI}	Optional input, 2.75V typ.	2.4	VDD+0.3	V	9, 10
PCI3/CFG0 Input	V _{IL_CFGMID}	Optional input, 1.65V typ.	1.3	2	V	9, 10
PCI3/CFG0 Input	V _{IL_CFGLO}	Optional input, 0.55V typ.	V _{SS} - 0.3	0.9	V	9, 10
Input Leakage Current	I _{IN}	V _{IN} = V _{DD} , V _{IN} = GND	-5	5	uA	2
Input Leakage Current	I _{INRES}	Inputs with pull up or pull down resistors V _{IN} = V _{DD} , V _{IN} = GND	-200	200	uA	
Output High Voltage	V _{OHSE}	Single-ended outputs, I _{OH} = -1mA	2.4		V	1
Output Low Voltage	V _{OLSE}	Single-ended outputs, I _{OL} = 1 mA		0.4	V	1
Operating Supply Current	I _{DDOP3.3}	Full Active, C _L = Full load; I _{dd} 3.3V		115	mA	
	I _{DDOPIO}	Full Active, C _L = Full load; IDD IO		55	mA	10
iAMT Mode Current	I _{DDIAMT3.3}	M1 mode, 3.3V Rail		36	mA	
	I _{DDIAMTIO}	M1 Mode, IO Rail		10	mA	
Powerdown Current	I _{DDPD3.3}	Power down mode, 3.3V Rail		5	mA	
	I _{DDPDIO}	Power down mode, IO Rail		0.1	mA	10
Input Frequency	F _i	V _{DD} = 3.3 V		15	MHz	
Pin Inductance	L _{pin}			7	nH	
Input Capacitance	C _{IN}	Logic Inputs	1.5	5	pF	
	C _{OUT}	Output pin capacitance		6	pF	
	C _{INX}	X1 & X2 pins		6	pF	
Clk Stabilization	T _{STAB}	From VDD Power-Up or de-assertion of PD to 1st clock		1.8	ms	
Tdrive_CR_off	T _{DRCROFF}	Output stop after CR deasserted		400	ns	
Tdrive_CR_on	T _{DRCRON}	Output run after CR asserted		0	us	
Tdrive_CPU	T _{DRSRC}	CPU output enable after PCI_STOP# de-assertion		10	ns	
Tfall_SE	T _{FALL}	Fall/rise time of all 3.3V control inputs from 20-80%		10	ns	
Trise_SE	T _{RISE}			10	ns	
SMBus Voltage	V _{DD}		2.7	5.5	V	
Low-level Output Voltage	V _{OLSMB}	@ I _{PULLUP}		0.4	V	
Current sinking at V _{OLSMB} = 0.4 V	I _{PULLUP}	SMB Data Pin	4		mA	
SCLK/SDATA Clock/Data Rise Time	T _{RI2C}	(Max V _{IL} - 0.15) to (Min V _{IH} + 0.15)		1000	ns	
SCLK/SDATA Clock/Data Fall Time	T _{FI2C}	(Min V _{IH} + 0.15) to (Max V _{IL} - 0.15)		300	ns	
Maximum SMBus Operating Frequency	F _{SMBUS}			100	kHz	
Spread Spectrum Modulation Frequency	f _{SSMOD}	Triangular Modulation	30	33	kHz	

ICS9EPRS525 56-pin CK505 for Embedded Systems

NOTES on Input/Supply/Common Output DC Parameters: (unless otherwise noted, guaranteed by design and characterization, not 100% tested in production).

¹Signal is required to be monotonic in this region.

²input leakage current does not include inputs with pull-up or pull-down resistors

³ 3.3V referenced inputs are: PCI_STOP#, CPU_STOP#, TME, SRC5_EN, ITP_EN, SCLKL, SDATA, TESTMODE, TESTSEL, CKPWRGD and CR# inputs if selected.

⁴ Intentionally blank

⁵ Maximum VIH is not to exceed VDD

⁶ Human Body Model

⁷ Operation under these conditions is neither implied, nor guaranteed.

⁸ Frequency Select pins which have tri-level input

⁹ PCI3/CFG0 is optional

¹⁰ If present. Not all parts have this feature.

AC Electrical Characteristics - Low Power Differential Outputs

PARAMETER	SYMBOL	CONDITIONS	MIN	MAX	UNITS	NOTES
Rising Edge Slew Rate	tSLR	Averaging on	2.5	4	V/ns	2, 3
Falling Edge Slew Rate	tFLR	Averaging on	2.5	4	V/ns	2, 3
Slew Rate Variation	tSLVAR	Averaging on		20	%	1, 10
Differential Voltage Swing	VSWING	Averaging off	300		mV	2
Crossing Point Voltage	VXABS	Averaging off	300	550	mV	1,4,5
Crossing Point Variation	VXABSVAR	Averaging off		140	mV	1,4,9
Maximum Output Voltage	VHIGH	Averaging off		1150	mV	1,7
Minimum Output Voltage	VLOW	Averaging off	-300		mV	1,8
Duty Cycle	DCYC	Averaging on	45	55	%	2
CPU[1:0] Skew	CPUSKEW10	Differential Measurement		100	ps	1
CPU[2 :ITP:0] Skew	CPUSKEW20	Differential Measurement		150	ps	1
SRC[10:0] Skew	SRCSEW	Differential Measurement		3000	ps	1,6

NOTES on DIF Output AC Specs: (unless otherwise noted, guaranteed by design and characterization, not 100% tested in production).

¹Measurement taken for single ended waveform on a component test board (not in system)

² Measurement taken from differential waveform on a component test board. (not in system)

³ Slew rate emasured through V_swing voltage range centered about differential zero

⁴ Vcross is defined at the voltage where Clock = Clock#, measured on a component test board (not in system)

⁵ Only applies to the differential rising edge (Clock rising, Clock# falling)

⁶ Total distributed intentional SRC to SRC skew. Maximum allowable interpair skew is 150 ps.

⁷ The max voltage including overshoot.

⁸ The min voltage including undershoot.

⁹ The total variation of all Vcross measurements in any particular system. Note this is a subset of V_cross min/mas (V_Cross absolute) allowed. The intent is to limit Vcross induced modulation by setting C_cross_delta to be smaller than V_Cross absolute

¹⁰ Matching applies to rising edge rate for Clock and falling edge rate for Clock#. It is measured using a +/-75mV window centered on the average cross point where Clock rising meets Clock# falling. The median cross point is used to calculate the voltage

Clock Jitter Specs - Low Power Differential Outputs

PARAMETER	SYMBOL	CONDITIONS	MIN	MAX	UNITS	NOTES
CPU Jitter - Cycle to Cycle	CPUJC2C	Differential Measurement		85	ps	1
SRC Jitter - Cycle to Cycle	SRCJC2C	Differential Measurement		125	ps	1
DOT Jitter - Cycle to Cycle	DOTJC2C	Differential Measurement		250	ps	1

NOTES on DIF Output Jitter: (unless otherwise noted, guaranteed by design and characterization, not 100% tested in production).

¹Jitter specs are specified as measured on a clock characterization board. System designers need to take special care not to use these numbers, as the in-system performance will be somewhat degraded. The receiver EMTS (chispet or CPU) will have the receiver

Differential Clock Tolerances

	CPU	SRC	DOT96		
PPM tolerance	100	100	100		ppm
Cycle to Cycle Jitter	85	125	250		ps
Spread	-0.50%	-0.50%	0		%

Clock Periods - Differential Outputs with Spread Spectrum Disabled

SSC OFF	Center Freq. MHz	Measurement Window							Units	Notes
		1 Clock	1us	0.1s	0.1s	0.1s	1us	1 Clock		
		-c2c jitter AbsPer Min	-SSC Short-Term Average Min	- ppm Long-Term Average Min	0 ppm Period Nominal	+ ppm Long-Term Average Max	+SSC Short-Term Average Max	+c2c jitter AbsPer Max		
CPU	100.00	9.91400		9.99900	10.00000	10.00100		10.08600	ns	1,2
	133.33	7.41425		7.49925	7.50000	7.50075		7.58575	ns	1,2
	166.67	5.91440		5.99940	6.00000	6.00060		6.08560	ns	1,2
	200.00	4.91450		4.99950	5.00000	5.00050		5.08550	ns	1,2
	266.67	3.66462		3.74962	3.75000	3.75037		3.83537	ns	1,2
	333.33	2.91470		2.99970	3.00000	3.00030		3.08530	ns	1,2
	400.00	2.41475		2.49975	2.50000	2.50025		2.58525	ns	1,2
SRC/SATA	100.00	9.87400	9.99900	10.00000	10.00100	10.12600	ns	1,2		
DOT96	96.00	10.16563	10.41563	10.41667	10.41771	10.66771	ns	1,2		

Clock Periods - Differential Outputs with Spread Spectrum Enabled

SSC ON	Center Freq. MHz	Measurement Window							Units	Notes
		1 Clock	1us	0.1s	0.1s	0.1s	1us	1 Clock		
		-c2c jitter AbsPer Min	-SSC Short-Term Average Min	- ppm Long-Term Average Min	0 ppm Period Nominal	+ ppm Long-Term Average Max	+SSC Short-Term Average Max	+c2c jitter AbsPer Max		
CPU	99.75	9.91406	9.99906	10.02406	10.02506	10.02607	10.05107	10.13607	ns	1,2
	133.00	7.41430	7.49930	7.51805	7.51880	7.51955	7.53830	7.62330	ns	1,2
	166.25	5.91444	5.99944	6.01444	6.01504	6.01564	6.03064	6.11564	ns	1,2
	199.50	4.91453	4.99953	5.01203	5.01253	5.01303	5.02553	5.11053	ns	1,2
	266.00	3.66465	3.74965	3.75902	3.75940	3.75977	3.76915	3.85415	ns	1,2
	332.50	2.91472	2.99972	3.00722	3.00752	3.00782	3.01532	3.10032	ns	1,2
	399.00	2.41477	2.49977	2.50602	2.50627	2.50652	2.51277	2.59777	ns	1,2
SRC	99.75	9.87406	9.99906	10.02406	10.02506	10.02607	10.05107	10.17607	ns	1,2

¹Guaranteed by design and characterization, not 100% tested in production.

²All Long Term Accuracy specifications are guaranteed with the assumption that the crystal input is tuned to exactly 14.31818MHz.

Electrical Characteristics - PCICLK/PCICLK_F

PARAMETER	SYMBOL	CONDITIONS	MIN	MAX	UNITS	NOTES
Long Accuracy	ppm	see T _{period} min-max values	-100	100	ppm	1,2
Clock period	T _{period}	33.33MHz output no spread	29.99700	30.00300	ns	2
		33.33MHz output spread	30.08421	30.23459	ns	2
Absolute min/max period	T _{abs}	33.33MHz output no spread	29.49700	30.50300	ns	2
		33.33MHz output nominal/spread	29.56617	30.58421	ns	2
Output High Voltage	V _{OH}	I _{OH} = -1 mA	2.4		V	1
Output Low Voltage	V _{OL}	I _{OL} = 1 mA		0.55	V	1
Output High Current	I _{OH}	V _{OH} @ MIN = 1.0 V	-33		mA	1
		V _{OH} @ MAX = 3.135 V		-33	mA	1
Output Low Current	I _{OL}	V _{OL} @ MIN = 1.95 V	30		mA	1
		V _{OL} @ MAX = 0.4 V		38	mA	1
Rising Edge Slew Rate	t _{SLR}	Measured from 0.8 to 2.0 V	1	4	V/ns	1
Falling Edge Slew Rate	t _{FLR}	Measured from 2.0 to 0.8 V	1	4	V/ns	1
Pin to Pin Skew	t _{skew}	V _T = 1.5 V		250	ps	2
Intentional PCI to PCI delay	t _{skew}	V _T = 1.5 V	100	200	ps	2
Duty Cycle	d _{t1}	V _T = 1.5 V	45	55	%	2
Jitter, Cycle to cycle	t _{JCYC-cyc}	V _T = 1.5 V		500	ps	2

Intentional PCI Clock to Clock Delay

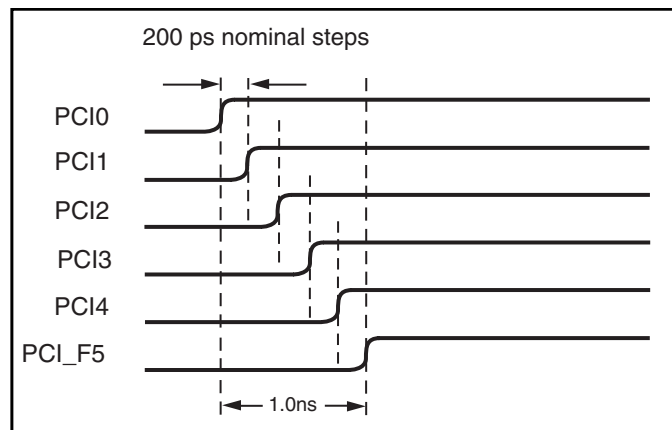

Electrical Characteristics - USB48MHz

PARAMETER	SYMBOL	CONDITIONS	MIN	MAX	UNITS	NOTES
Long Accuracy	ppm	see T _{period} min-max values	-100	100	ppm	2,4
Clock period	T _{period}	48.00MHz output nominal	20.83125	20.83542	ns	2,3
Absolute min/max period	T _{abs}	48.00MHz output nominal	20.48125	21.18542	ns	2
CLK High Time	T _{HIGH}		8.216563	11.15198	V	
CLK Low time	T _{LOW}		7.816563	10.95198	V	
Output High Voltage	V _{OH}	I _{OH} = -1 mA	2.4		V	
Output Low Voltage	V _{OL}	I _{OL} = 1 mA		0.55	V	
Output High Current	I _{OH}	V _{OH} @ MIN = 1.0 V	-29		mA	
		V _{OH} @ MAX = 3.135 V		-23	mA	
Output Low Current	I _{OL}	V _{OL} @ MIN = 1.95 V	29		mA	
		V _{OL} @ MAX = 0.4 V		27	mA	
Rising Edge Slew Rate	t _{SLR}	Measured from 0.8 to 2.0 V	1	2	V/ns	1
Falling Edge Slew Rate	t _{FLR}	Measured from 2.0 to 0.8 V	1	2	V/ns	1
Duty Cycle	d _{t1}	V _T = 1.5 V	45	55	%	2
Jitter, Cycle to cycle	t _{JCYC-cyc}	V _T = 1.5 V		350	ps	2

Electrical Characteristics - REF-14.318MHz

PARAMETER	SYMBOL	CONDITIONS	MIN	MAX	UNITS	Notes
Long Accuracy	ppm	see Tperiod min-max values	-100	100	ppm	2, 4
Clock period	Tperiod	14.318MHz output nominal	69.82033	69.86224	ns	2, 3
Absolute min/max period	Tab	14.318MHz output nominal	69.83400	70.84800	ns	2
CLK High Time	THIGH		29.97543	38.46654	V	
CLK Low time	TLOW		29.57543	38.26654	V	
Output High Voltage	VOH	IOH = -1 mA	2.4		V	
Output Low Voltage	VOL	IOL = 1 mA		0.4	V	
Output High Current	IOH	VOH @MIN = 1.0 V, VOH@MAX = 3.135 V	-33	-33	mA	
Output Low Current	IOL	VOL @MIN = 1.95 V, VOL @MAX = 0.4 V	30	38	mA	
Rising Edge Slew Rate	tSLR	Measured from 0.8 to 2.0 V	1	4	V/ns	1
Falling Edge Slew Rate	tFLR	Measured from 2.0 to 0.8 V	1	4	V/ns	1
Duty Cycle	dt1	VT = 1.5 V	45	55	%	2
Jitter, Cycle to cycle	tjyc-cyc	VT = 1.5 V		1000	ps	2

NOTES on SE outputs: (unless otherwise noted, guaranteed by design and characterization, not 100% tested in production).

¹Edge rate in system is measured from 0.8V to 2.0V.

²Duty cycle, Period and Jitter are measured with respect to 1.5V

³The average period over any 1us period of time

⁴Using frequency counter with the measurement interval equal or greater that 0.15s, target frequencies are 14.318180 MHz, 33.333333MHz and 48.000000MHz

Table 1: CPU Frequency Select Table

FS _L C ² B0b7	FS _L B ¹ B0b6	FS _L A ¹ B0b5	CPU MHz	SRC MHz	PCI MHz	REF MHz	USB MHz	DOT MHz
0	0	0	266.66	100.00	33.33	14.318	48.00	96.00
0	0	1	133.33					
0	1	0	200.00					
0	1	1	166.66					
1	0	0	333.33					
1	0	1	100.00					
1	1	0	400.00					
1	1	1	Reserved					

1. FS_LA and FS_LB are low-threshold inputs. Please see V_{IL_FS} and V_{IH_FS} specifications in the Input/Supply/Common Output Parameters Table for correct values.
Also refer to the Test Clarification Table.
2. FS_LC is a three-level input. Please see the V_{IL_FS} and V_{IH_FS} specifications in the Input/Supply/Common Output Parameters Table for correct values.

Table 2: PLL3 Quick Configuration (only applies in Mode 0, see Table 6)

B1b4	B1b3	B1b2	B1b1	Pin 17	Pin 18	Spread	Comment
				MHz	MHz	%	
0	0	0	0	PLL 3 disabled			
0	0	0	1	100.00	100.00	0.5% Down Spread	SRC clocks from SRC_MAIN
0	0	1	0	100.00	100.00	0.5% Down Spread	Only SRCCLK1 from PLL3
0	0	1	1	100.00	100.00	1% Down Spread	Only SRCCLK1 from PLL3
0	1	0	0	100.00	100.00	1.5% Down Spread	Only SRCCLK1 from PLL3
0	1	0	1	100.00	100.00	2% Down Spread	Only SRCCLK1 from PLL3
0	1	1	0	100.00	100.00	2.5% Down Spread	Only SRCCLK1 from PLL3
0	1	1	1	N/A	N/A	N/A	N/A
1	0	0	0	24.576	24.576	None	24.576Mhz on SE1 and SE2
1	0	0	1	24.576	98.304	None	24.576Mhz on SE1, 98.304Mhz on SE2
1	0	1	0	98.304	98.304	None	98.304Mhz on SE1 and SE2
1	0	1	1	27.000	27.000	None	27Mhz on SE1 and SE2
1	1	0	0	25.000	25.000	None	25Mhz on SE1 and SE2
1	1	0	1	N/A	N/A	N/A	N/A
1	1	1	0	N/A	N/A	N/A	N/A
1	1	1	1	N/A	N/A	N/A	N/A

Table 3: IO_Vout select table

B9b2	B9b1	B9b0	IO_Vout
0	0	0	0.3V
0	0	1	0.4V
0	1	0	0.5V
0	1	1	0.6V
1	0	0	0.7V
1	0	1	0.8V
1	1	0	0.9V
1	1	1	1.0V

Table 4: Device ID table

B8b7	B8b6	B8b5	B8b4	Comment
0	0	0	0	56 pin TSSOP

Table 5: Slew Rate Selection Table

Bit 1	Bit 0	Slew Rate
0	0	HI-Z
0	1	0.7X (1.4V/ns)
1	0	0.8X (1.6 V/ns)
1	1	1X (2.0 V/ns)

Table 6. PCI3 Configuration Table

PCI3/CFG0 HW Strap	PCI2/TME HW Strap	Note: 2 bits are needed since CFG0 is tri-level input		SRC_Main_SE L (Byte 0, bit 2)	Config Mode
		PCI3_CFG1 (Byte 11, bit 7)	PCI3_CFG0 (Byte 11, bit 6)		
Low	0 or 1	0	0	0	0 = Default
Mid	0 or 1	0	1	1	1
High	TME=0	1	0	1	2
High	TME=1	1	1	1	3

Table 7. PLL Modes for PCI3 Configurations

Config Mode	PLL1		PLL2		PLL3		SRC1	PLL Source
	Outputs	SSC	Outputs	SSC	Outputs	SSC		
0 = Default	CPU/SRC/ PCI	Down	USB	NA	-	-	100MHz	PLL1 (Table 2 applies)
1	CPU	Down	USB	NA	SRC/PCI	Down	100MHz	PLL3
2	CPU	Center	USB	NA	SRC/PCI	Down	100MHz	PLL3
3	CPU	Center	USB/LAN25	NA	SRC/PCI	Down	25MHz SE	PLL2*

*Note: In Mode 3, Byte 8, bit (1:0) must be set to '1' to enable pin 17,18

Table 8. ME Clock Selection Table

PCIF5/ ITP_EN	iAMT_EN	CPU2_AMT_EN	CPU1_AMT_EN	Description
x	1	0	0	Reserved
x	1	0	1	Default, CPU1 = iAMT Clock
1	1	1	0	CPU2 = iAMT Clock
1	1	1	1	CPU1 and CPU2 both run in iAMT mode

PCI_STOP# Power Management

SMBus OE Bit	PCI_STOP#	Single-ended Clocks		Differential Clocks (Except CPU)	
		Stoppable	Free running	Stoppable	Free running
Enable	1	Running	Running	Running	Running
	0	Low	Low	CK= High CK# = Low	Running
				CK= Pull down CK# = Low	Running
Disable	X	Low		CK= Pull down, CK# = Low	

CPU_STOP# Power Management

SMBus OE Bit	PCI_STOP#	Differential Clocks	
		Stoppable	Free running
Enable	1	Running	Running
	0	CK= High CK# = Low	Running
		CK= Pull down CK# = Low	Running
Disable	X	Low	

CR# Power Management

SMBus OE Bit	CR#	Differential Clocks	
		Stoppable	Free running
Enable	1	Running	Running
	0	CK= Pull down, CK# = Low	
Disable	X	CK = Pull down, CK# = Low	

PD# Power Management

Device State	Single-ended Clocks		Differential Clocks (Except CPU1)	CPU1
	w/o Latched input	w/Latched input		
Latches Open	Low	Hi-Z	CK= Pull down, CK# = Low	CK= Pull down, CK# = Low
Power Down			CK= Pull down CK# = Low	CK= Pull down CK# = Low
M1			CK= Pull down CK# = Low	Running
Virtual Power Cycle to Latches Open			CK= Pull down, CK# = Low	CK= Pull down, CK# = Low

General SMBus serial interface information for the ICS9EPRS525

How to Write:

- Controller (host) sends a start bit.
- Controller (host) sends the write address $D2_{(H)}$
- ICS clock will **acknowledge**
- Controller (host) sends the beginning byte location = N
- ICS clock will **acknowledge**
- Controller (host) sends the data byte count = X
- ICS clock will **acknowledge**
- Controller (host) starts sending **Byte N through Byte N + X - 1**
- ICS clock will **acknowledge** each byte **one at a time**
- Controller (host) sends a Stop bit

How to Read:

- Controller (host) will send start bit.
- Controller (host) sends the write address $D2_{(H)}$
- ICS clock will **acknowledge**
- Controller (host) sends the beginning byte location = N
- ICS clock will **acknowledge**
- Controller (host) will send a separate start bit.
- Controller (host) sends the read address $D3_{(H)}$
- ICS clock will **acknowledge**
- ICS clock will send the data byte count = X
- ICS clock sends **Byte N + X - 1**
- ICS clock sends **Byte 0 through byte X (if $X_{(H)}$ was written to byte 8).**
- Controller (host) will need to acknowledge each byte
- Controller (host) will send a not acknowledge bit
- Controller (host) will send a stop bit

Index Block Write Operation		
Controller (Host)		ICS (Slave/Receiver)
T	starT bit	
Slave Address $D2_{(H)}$		
WR	WRite	
		ACK
Beginning Byte = N		
		ACK
Data Byte Count = X		
		ACK
Beginning Byte N		X Byte
○		
○		
○		
Byte N + X - 1		
		ACK
P	stoP bit	

Index Block Read Operation		
Controller (Host)		ICS (Slave/Receiver)
T	starT bit	
Slave Address $D2_{(H)}$		
WR	WRite	
		ACK
Beginning Byte = N		
		ACK
RT	Repeat starT	
Slave Address $D3_{(H)}$		
RD	ReaD	
		ACK
		Data Byte Count = X
ACK		X Byte
ACK		
○		
○		
○		
		Byte N + X - 1
N	Not acknowledge	
P	stoP bit	

Byte 0 FS Readback and PLL Selection Register

Bit	Pin	Name	Description	Type	0	1	Default
7	-	FSLC	CPU Freq. Sel. Bit (Most Significant)	R	See Table 1 : CPU Frequency Select Table		Latch
6	-	FSLB	CPU Freq. Sel. Bit	R			Latch
5	-	FSLA	CPU Freq. Sel. Bit (Least Significant)	R			Latch
4	-	iAMT_EN	Set via SMBus or dynamically by CK505 if detects dynamic M1	RW	Legacy Mode	iAMT Enabled	0
3		Reserved	Reserved	RW			0
2	-	SRC_Main_SEL	Select source for SRC Main	RW	SRC Main = PLL1	SRC Main = PLL3	Latch
1	-	SATA_SEL	Select source for SATA clock	RW	SATA = SRC_Main	SATA = PLL2	0
0	-	PD_Restore	1 = on Power Down de-assert return to last known state 0 = clear all SMBus configurations as if cold power-on and go to latches open state This bit is ignored and treated at '1' if device is in iAMT mode.	RW	Configuration Not Saved	Configuration Saved	1

Byte 1 DOT96 Select and PLL3 Quick Config Register

Bit	Pin	Name	Description	Type	0	1	Default
7	13/14	SRC0_SEL	Select SRC0 or DOT96	RW	SRC0	DOT96	0
6	-	PLL1_SSC_SEL	Select 0.5% down or center SSC	RW	Down spread	Center spread	Latch
5		PLL3_SSC_SEL	Select 0.5% down or center SSC	RW	Down spread	Center spread	0
4		PLL3_CF3	PLL3 Quick Config Bit 3	RW	See Table 2: PLL3 Quick Configuration Only applies if Byte 0, bit 2 = 0.		0
3		PLL3_CF2	PLL3 Quick Config Bit 2	RW			0
2		PLL3_CF1	PLL3 Quick Config Bit 1	RW			0
1		PLL3_CF0	PLL3 Quick Config Bit 0	RW			1
0		PCI_SEL	PCI_SEL	RW	PCI from PLL1	PCI from SRC_MAIN	1

Byte 2 Output Enable Register

Bit	Pin	Name	Description	Type	0	1	Default
7		REF_OE	Output enable for REF, if disabled output is tri-stated	RW	Output Disabled	Output Enabled	1
6		USB_OE	Output enable for USB	RW	Output Disabled	Output Enabled	1
5		PCIF5_OE	Output enable for PCI5	RW	Output Disabled	Output Enabled	1
4		PCI4_OE	Output enable for PCI4	RW	Output Disabled	Output Enabled	1
3		PCI3_OE	Output enable for PCI3	RW	Output Disabled	Output Enabled	1
2		PCI2_OE	Output enable for PCI2	RW	Output Disabled	Output Enabled	1
1		PCI1_OE	Output enable for PCI1	RW	Output Disabled	Output Enabled	1
0		PCIO_OE	Output enable for PCIO	RW	Output Disabled	Output Enabled	1

Byte 3 Output Enable Register

Bit	Pin	Name	Description	Type	0	1	Default
7		Reserved	Reserved	RW	-	-	1
6		Reserved	Reserved	RW	-	-	1
5		Reserved	Reserved	RW	-	-	1
4		SRC8/ITP_OE	Output enable for SRC8 or ITP	RW	Output Disabled	Output Enabled	1
3		SRC7_OE	Output enable for SRC7	RW	Output Disabled	Output Enabled	1
2		SRC6_OE	Output enable for SRC6	RW	Output Disabled	Output Enabled	1
1		SRC5_OE	Output enable for SRC5	RW	Output Disabled	Output Enabled	1
0		SRC4_OE	Output enable for SRC4	RW	Output Disabled	Output Enabled	1

Byte 4 Output Enable and Spread Spectrum Disable Register

Bit	Pin	Name	Description	Type	0	1	Default
7		SRC3_OE	Output enable for SRC3	RW	Output Disabled	Output Enabled	1
6		SATA/SRC2_OE	Output enable for SATA/SRC2	RW	Output Disabled	Output Enabled	1
5		SRC1_OE	Output enable for SRC1	RW	Output Disabled	Output Enabled	1
4		SRC0/DOT96_OE	Output enable for SRC0/DOT96	RW	Output Disabled	Output Enabled	1
3		CPU1_OE	Output enable for CPU1	RW	Output Disabled	Output Enabled	1
2		CPU0_OE	Output enable for CPU0	RW	Output Disabled	Output Enabled	1
1		PLL1_SSC_ON	Enable PLL1's spread modulation	RW	Spread Disabled	Spread Enabled	1
0		PLL3_SSC_ON	Enable PLL3's spread modulation	RW	Spread Disabled	Spread Enabled	1

Byte 5 Clock Request Enable/Configuration Register

Bit	Pin	Name	Description	Type	0	1	Default
7		CR#_A_EN	Enable CR#_A (clk req), PCI0_OE must be = 1 for this bit to take effect	RW	Disable CR#_A	Enable CR#_A	0
6		CR#_A_SEL	Sets CR#_A to control either SRC0 or SRC2	RW	CR#_A -> SRC0	CR#_A -> SRC2	0
5		CR#_B_EN	Enable CR#_B (clk req)	RW	Disable CR#_B	Enable CR#_B	0
4		CR#_B_SEL	Sets CR#_B -> SRC1 or SRC4	RW	CR#_B -> SRC1	CR#_B -> SRC4	0
3		CR#_C_EN	Enable CR#_C (clk req)	RW	Disable CR#_C	Enable CR#_C	0
2		CR#_C_SEL	Sets CR#_C -> SRC0 or SRC2	RW	CR#_C -> SRC0	CR#_C -> SRC2	0
1		CR#_D_EN	Enable CR#_D (clk req)	RW	Disable CR#_D	Enable CR#_D	0
0		CR#_D_SEL	Sets CR#_D -> SRC1 or SRC4	RW	CR#_D -> SRC1	CR#_D -> SRC4	0

Byte 6 Clock Request Enable/Configuration and Stop Control Register

Bit	Pin	Name	Description	Type	0	1	Default
7		CR#_E_EN	Enable CR#_E (clk req) -> SRC6	RW	Disable CR#_E	Enable CR#_E	0
6		CR#_F_EN	Enable CR#_F (clk req) -> SRC8	RW	Disable CR#_F	Enable CR#_F	0
5		Reserved	Reserved	RW	-	-	0
4		Reserved	Reserved	RW	-	-	0
3		Reserved	Reserved	RW	-	-	0
2		Reserved	Reserved	RW	-	-	0
1		SSCD_STP_CRTL (SRC1)	If set, SSCD (SRC1) stops with PCI_STOP#	RW	Free Running	Stops with PCI_STOP# assertion	0
0		SRC_STP_CRTL	If set, SRCs (except SRC1) stop with PCI_STOP#	RW	Free Running	Stops with PCI_STOP# assertion	0

Byte 7 Vendor ID/ Revision ID

Bit	Pin	Name	Description	Type	0	1	Default
7		Rev Code Bit 3	Revision ID	R	Vendor specific		X
6		Rev Code Bit 2		R			X
5		Rev Code Bit 1		R			X
4		Rev Code Bit 0		R			X
3		Vendor ID bit 3	Vendor ID ICS is 0001, binary	R			0
2		Vendor ID bit 2		R			0
1		Vendor ID bit 1		R			0
0		Vendor ID bit 0		R			1

Byte 8 Device ID and Output Enable Register

Bit	Pin	Name	Description	Type	0	1	Default
7		Device_ID3	Table of Device identifier codes, used for differentiating between CK505 package options, etc.	R	56-pin device		0
6		Device_ID2		R			0
5		Device_ID1		R			0
4		Device_ID0		R			0
3		Reserved	Reserved	RW	-	-	0
2		Reserved	Reserved	RW	-	-	0
1		SE1_OE	Output enable for SE1	RW	Disabled	Enabled	0
0		SE2_OE	Output enable for SE2	RW	Disabled	Enabled	0

Byte 9 Output Control Register

Bit	Pin	Name	Description	Type	0	1	Default
7		PCIF5_STOP_EN	Allows control of PCIF5 with assertion of PCI_STOP#	RW	Free running	Stops with PCI_STOP# assertion	0
6		TME_Readback	Trusted Mode Enable (TME) strap status	R	normal operation	no overclocking	Latch
5		REF Strength	Sets the REF output drive strength	RW	1X (2Loads)	2X (3 Loads)	1
4		Test Mode Select	Allows test select, ignores REF/FSC/TestSel	RW	Outputs HI-Z	Outputs = REF/N	0
3		Test Mode Entry	Allows entry into test mode, ignores FSB/TestMode	RW	Normal operation	Test mode	0
2		IO_VOUT2	IO Output Voltage Select (Most Significant Bit)	RW	See Table 3: V_IO Selection (Default is 0.8V)		1
1		IO_VOUT1	IO Output Voltage Select	RW			0
0		IO_VOUT0	IO Output Voltage Select (Least Significant Bit)	RW			1

Byte 10 Stop Enable Register

Bit	Pin	Name	Description	Type	0	1	Default
7		SRC5_EN Readback	Readback of SRC5 enable latch	R	CPU/PCI Stop Enabled	SRC5 Enabled	Latch
6		Reserved	Reserved	RW	-	-	0
5		Reserved		RW	-	-	0
4		Reserved		RW	-	-	0
3		Reserved		RW	-	-	0
2		Reserved		RW	-	-	0
1		CPU 1 Stop Enable		Enables control of CPU1 with CPU_STOP#	RW	Free Running	Stoppable
0		CPU 0 Stop Enable	Enables control of CPU 0 with CPU_STOP#	RW	Free Running	Stoppable	1

Byte 11 iAMT Enable Register

Bit	Pin	Name	Description	Type	0	1	Default
7		PCI3_CFG1	See PCI3 Configuration Table 28	R	See PCI3 Configuration Table		Latch
6		PCI3_CFG0		R			Latch
5		Reserved	Reserved	RW	-	-	0
4		Reserved	Reserved	RW	-	-	1
3		CPU2_AMT_EN	Determines if CPU2 runs in M1 mode. Only valid if ITP_EN=1. See Note.	RW	Does not Run	Runs	0
2		CPU1_AMT_EN	Determines if CPU1 runs in M1 mode. See Note.	RW	Does not Run	Runs	1
1		PCI-E_GEN2	Determines if PCI-E Gen2 compliant	R	non-Gen2	PCI-E Gen2 Compliant	1
0		CPU 2 Stop Enable	Enables control of CPU 0 with CPU_STOP#	RW	Free Running	Stoppable	1

NOTE: A value of '00' for Bit(3:2) in Byte 11 is reserved and not a valid configuration.

Byte 12 Byte Count Register

Bit	Pin	Name	Description	Type	0	1	Default
7		Reserved		RW			0
6		Reserved		RW			0
5		BC5	Read Back byte count register, max bytes = 32	RW			0
4		BC4		RW			0
3		BC3		RW			1
2		BC2		RW			1
1		BC1		RW			0
0		BC0		RW			1

Byte 13 to 28 Reserved**Byte 29 Slew Rate Control**

Bit	Pin	Name	Description	RW	0	1	Default
7		USB_Slew1	USB Slew Rate Control (MSB)	RW	See Slew Rate Selection Table		1
6		USB_Slew0	USB Slew Rate Control (LSB)	RW			0
5		PCI_Slew1	PCI Slew Rate Control (MSB)	RW	See Slew Rate Selection Table		1
4		PCI_Slew0	PCI Slew Rate Control (LSB)	RW			1
3		Reserved		RW			1
2		REF Slew Rate	Changes Ref Slew Rate	RW	1.2V/ns	2.2V/ns	1
1		Reserved		RW			0
0		Reserved		RW			0

Test Clarification Table

Comments	HW		SW		OUTPUT
	FSLC/ TEST_SEL HW PIN	FSLB/ TEST_MODE HW PIN	TEST ENTRY BIT B9b3	REF/N or HI-Z B9b4	
	<2.0V	X	0	0	NORMAL
Power-up w/ TEST_SEL = 1 to enter test mode	>2.0V	0	X	0	HI-Z
Cycle power to disable test mode	>2.0V	0	X	1	REF/N
FSLC./TEST_SEL -->3-level latched input	>2.0V	1	X	0	REF/N
If power-up w/ V>2.0V then use TEST_SEL					
If power-up w/ V<2.0V then use FSLC					
FSLB/TEST_MODE -->low Vth input	>2.0V	1	X	1	REF/N
TEST_MODE is a real time input					
If TEST_SEL HW pin is 0 during power-up, test mode can be invoked through B9b3. If test mode is invoked by B9b3, only B9b4 is used to select HI-Z or REF/N FSLB/TEST_Mode pin is not used. Cycle power to disable test mode, one shot control	<2.0V	X	1	0	HI-Z
	<2.0V	X	1	1	REF/N

B9b3: 1= ENTER TEST MODE, Default = 0 (NORMAL OPERATION)

B9b4: 1= REF/N, Default = 0 (HI-Z)

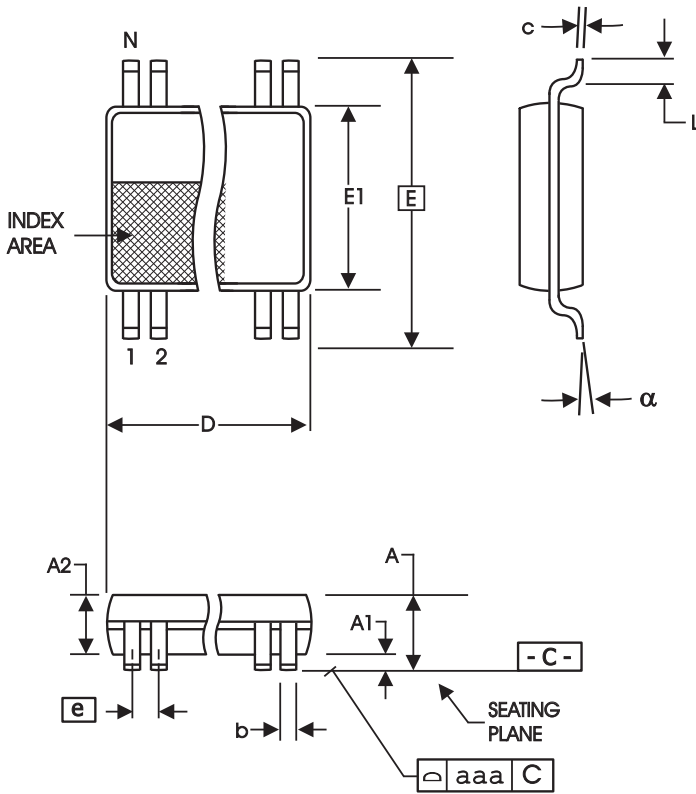

56-Lead 6.10 mm. Body, 0.50 mm. Pitch TSSOP
(240 mil) (20 mil)

SYMBOL	In Millimeters COMMON DIMENSIONS		In Inches COMMON DIMENSIONS	
	MIN	MAX	MIN	MAX
A	--	1.20	--	.047
A1	0.05	0.15	.002	.006
A2	0.80	1.05	.032	.041
b	0.17	0.27	.007	.011
c	0.09	0.20	.0035	.008
D	SEE VARIATIONS		SEE VARIATIONS	
E	8.10 BASIC		0.319 BASIC	
E1	6.00	6.20	.236	.244
e	0.50 BASIC		0.020 BASIC	
L	0.45	0.75	.018	.030
N	SEE VARIATIONS		SEE VARIATIONS	
alpha	0°	8°	0°	8°
aaa	--	0.10	--	.004

VARIATIONS

N	D mm.		D (inch)	
	MIN	MAX	MIN	MAX
56	13.90	14.10	.547	.555

Reference Doc.: JEDEC Publication 95, M O-153

10-0039

Ordering Information

Part/Order Number	Shipping Packaging	Package	Temperature
9EPRS525AGLF	Tubes	56-pin TSSOP	0 to +70° C
9EPRS525AGLFT	Tape and Reel	56-pin TSSOP	0 to +70° C
9EPRS525AGILF	Tubes	56-pin TSSOP	-40 to +85° C
9EPRS525AGILFT	Tape and Reel	56-pin TSSOP	-40 to +85° C

Parts that are ordered with a "LF" suffix to the part number are the Pb-Free configuration and are RoHS compliant. Due to package size constraints, actual top-side marking may differ from the full orderable part number.

Revision History

Rev.	Issue Date	Description	Page #
0.1	7/31/2009	Initial Release	-
A	8/19/2009	Released to final.	
B	1/21/2010	Updated Power Groups table.	4

This product is protected by United States Patent NO. 7,342,420 and other patents.

IMPORTANT NOTICE AND DISCLAIMER

RENESAS ELECTRONICS CORPORATION AND ITS SUBSIDIARIES (“RENESAS”) PROVIDES TECHNICAL SPECIFICATIONS AND RELIABILITY DATA (INCLUDING DATASHEETS), DESIGN RESOURCES (INCLUDING REFERENCE DESIGNS), APPLICATION OR OTHER DESIGN ADVICE, WEB TOOLS, SAFETY INFORMATION, AND OTHER RESOURCES “AS IS” AND WITH ALL FAULTS, AND DISCLAIMS ALL WARRANTIES, EXPRESS OR IMPLIED, INCLUDING, WITHOUT LIMITATION, ANY IMPLIED WARRANTIES OF MERCHANTABILITY, FITNESS FOR A PARTICULAR PURPOSE, OR NON-INFRINGEMENT OF THIRD-PARTY INTELLECTUAL PROPERTY RIGHTS.

These resources are intended for developers who are designing with Renesas products. You are solely responsible for (1) selecting the appropriate products for your application, (2) designing, validating, and testing your application, and (3) ensuring your application meets applicable standards, and any other safety, security, or other requirements. These resources are subject to change without notice. Renesas grants you permission to use these resources only to develop an application that uses Renesas products. Other reproduction or use of these resources is strictly prohibited. No license is granted to any other Renesas intellectual property or to any third-party intellectual property. Renesas disclaims responsibility for, and you will fully indemnify Renesas and its representatives against, any claims, damages, costs, losses, or liabilities arising from your use of these resources. Renesas' products are provided only subject to Renesas' Terms and Conditions of Sale or other applicable terms agreed to in writing. No use of any Renesas resources expands or otherwise alters any applicable warranties or warranty disclaimers for these products.

(Disclaimer Rev.1.01 Jan 2024)

Corporate Headquarters

TOYOSU FORESIA, 3-2-24 Toyosu,
Koto-ku, Tokyo 135-0061, Japan
www.renesas.com

Trademarks

Renesas and the Renesas logo are trademarks of Renesas Electronics Corporation. All trademarks and registered trademarks are the property of their respective owners.

Contact Information

For further information on a product, technology, the most up-to-date version of a document, or your nearest sales office, please visit www.renesas.com/contact-us/.

Looking for pricing, stock, or lifecycle information?

Click below to explore more details on WIN SOURCE:

-  [View 9EPRS525AGILFT on WIN SOURCE](#)
-  [Renesas Electronics America](#) Information

Optimize Your Supply Chain with WIN SOURCE Solutions

-  Global Sourcing Solution
-  Obsolete Management
-  Cost Control Management
-  Shortage Management
-  Alternative Solution
-  Excess Inventory Management