



**THE DATASHEET OF  
9EPRS488CKLFT**





## Pin Description

PIN #	PIN NAME	PIN TYPE	DESCRIPTION
1	SMBCLK	IN	Clock pin of SMBus circuitry, 5V tolerant.
2	SMBDAT	I/O	Data pin for SMBus circuitry, 5V tolerant.
3	VDD	PWR	Power supply for SRC7/27MHz
4	SRC7C_LPRS/27MHz_NS	OUT	True clock of low power differential SRC clock pair. (no 50ohm shunt resistor to GND and no 33 ohm series resistor needed)/27MHz 3.3V Single-ended non-spread output for discrete graphics
5	SRC7T_LPRS/27MHz_SS	OUT	Complement clock of low power differential SRC clock pair. (no 50ohm shunt resistor to GND and no 33 ohm series resistor needed)/27MHz 3.3V Single-ended spreading output for discrete graphics
6	GND	GND	Ground pin for SRC7/27MHz
7	SRC5C_LPRS	OUT	Complement clock of low power differential SRC clock pair. (no 50ohm shunt resistor to GND and no 33 ohm series resistor needed)
8	SRC5T_LPRS	OUT	True clock of low power differential SRC clock pair. (no 50ohm shunt resistor to GND and no 33 ohm series resistor needed)
9	SRC4C_LPRS	OUT	Complement clock of low power differential SRC clock pair. (no 50ohm shunt resistor to GND and no 33 ohm series resistor needed)
10	SRC4T_LPRS	OUT	True clock of low power differential SRC clock pair. (no 50ohm shunt resistor to GND and no 33 ohm series resistor needed)
11	GNDSRC	GND	Ground pin for the SRC outputs
12	VDDSRC_IO	PWR	Power supply for differential SRC outputs, nominal 1.05V to 3.3V
13	SRC3C_LPRS	OUT	Complement clock of low power differential SRC clock pair. (no 50ohm shunt resistor to GND and no 33 ohm series resistor needed)
14	SRC3T_LPRS	OUT	True clock of low power differential SRC clock pair. (no 50ohm shunt resistor to GND and no 33 ohm series resistor needed)
15	SRC2C_LPRS	OUT	Complement clock of low power differential SRC clock pair. (no 50ohm shunt resistor to GND and no 33 ohm series resistor needed)
16	SRC2T_LPRS	OUT	True clock of low power differential SRC clock pair. (no 50ohm shunt resistor to GND and no 33 ohm series resistor needed)
17	VDDSRC	PWR	Supply for SRC core, 3.3V nominal
18	VDDSRC_IO	PWR	Power supply for differential SRC outputs, nominal 1.05V to 3.3V
19	GNDSRC	GND	Ground pin for the SRC outputs
20	SRC1C_LPRS	OUT	Complement clock of low power differential SRC clock pair. (no 50ohm shunt resistor to GND and no 33 ohm series resistor needed)
21	SRC1T_LPRS	OUT	True clock of low power differential SRC clock pair. (no 50ohm shunt resistor to GND and no 33 ohm series resistor needed)
22	SRC0C_LPRS	OUT	Complement clock of low power differential SRC clock pair. (no 50ohm shunt resistor to GND and no 33 ohm series resistor needed)
23	SRC0T_LPRS	OUT	True clock of low power differential SRC clock pair. (no 50ohm shunt resistor to GND and no 33 ohm series resistor needed)
24	**CLKREQ0#	IN	Clock Request pin for SRC0 outputs. If output is selected for control, then that output is controlled as follows: 0 = enabled, 1 = Low-Low
25	ATIG2C_LPRS	OUT	Complementary clock of low-power differential push-pull PCI-Express pair with integrated series resistor. (no 50ohm shunt resistor to GND and no 33 ohm series resistor needed)
26	ATIG2T_LPRS	OUT	True clock of low-power differential push-pull PCI-Express pair with integrated series resistor. (no 50ohm shunt resistor to GND and no 33 ohm series resistor needed)
27	GNDATIG	GND	Ground pin for the ATIG outputs
28	VDDATIG_IO	PWR	Power supply for differential ATIG outputs, nominal 1.05V to 3.3V
29	VDDATIG	PWR	Power supply for ATIG core, nominal 3.3V
30	ATIG1C_LPRS	OUT	Complementary clock of low-power differential push-pull PCI-Express pair with integrated series resistor. (no 50ohm shunt resistor to GND and no 33 ohm series resistor needed)
31	ATIG1T_LPRS	OUT	True clock of low-power differential push-pull PCI-Express pair with integrated series resistor. (no 50ohm shunt resistor to GND and no 33 ohm series resistor needed)
32	ATIG0C_LPRS	OUT	Complementary clock of low-power differential push-pull PCI-Express pair with integrated series resistor. (no 50ohm shunt resistor to GND and no 33 ohm series resistor needed)
33	ATIG0T_LPRS	OUT	True clock of low-power differential push-pull PCI-Express pair with integrated series resistor. (no 50ohm shunt resistor to GND and no 33 ohm series resistor needed)
34	SB_SRC1C_LPRS	OUT	Complement clock of low power differential Chipset-to-Chipset SRC clock pair. (no 50ohm shunt resistor to GND and no 33 ohm series resistor needed)
35	SB_SRC1T_LPRS	OUT	True clock of low power differential Chipset-to-Chipset SRC clock pair. (no 50ohm shunt resistor to GND and no 33 ohm series resistor needed)
36	GNDSB_SRC	GND	Ground pin for the SB_SRC outputs

## Pin Description (Continued)

PIN #	PIN NAME	PIN TYPE	DESCRIPTION
37	VDDSB_SRC_IO	PWR	Power supply for differential SB_SRC outputs, nominal 1.05V to 3.3V
38	VDDSB_SRC	PWR	Supply for SB SRC PLL core, 3.3V nominal
39	SB_SRC0C_LPRS	OUT	Complement clock of low power differential Chipset-to-Chipset SRC clock pair. (no 50ohm shunt resistor to GND and no 33 ohm series resistor needed)
40	SB_SRC0T_LPRS	OUT	True clock of low power differential Chipset-to-Chipset SRC clock pair. (no 50ohm shunt resistor to GND and no 33 ohm series resistor needed)
41	SB_SRC_SLOW#*	IN	When low, this real-time, level-sensitive input slows down the SB_SRC outputs to a user determined lower frequency to save power. The default lower frequency is 80 MHz. 0 = Slow Down, 1 = normal operation.
42	CLKREQ4#**	IN	Clock Request pin for SRC4/5 outputs. If output is selected for control, then that output is controlled as follows: 0 = enabled, 1 = Low-Low
43	CLKREQ3#**	IN	Clock Request pin for SRC3 outputs. If output is selected for control, then that output is controlled as follows: 0 = enabled, 1 = Low-Low
44	VDDSA	PWR	Power supply for SATA core logic, nominal 3.3V
45	SRC6C/SATAC_LPRS	OUT	Complement clock of low power differential SRC/SATA clock pair. (no 50ohm shunt resistor to GND and no 33 ohm series resistor needed)
46	SRC6T/SATAT_LPRS	OUT	True clock of low power differential SRC clock pair. (no 50ohm shunt resistor to GND and no 33 ohm series resistor needed)
47	GNDSATA	GND	Ground pin for the SRC outputs
48	GNDA	GND	Ground for the Analog Core
49	VDDA	PWR	3.3V Power for the Analog Core
50	CLKREQ2#**	IN	Clock Request pin for SRC2 outputs. If output is selected for control, then that output is controlled as follows: 0 = enabled, 1 = Low-Low
51	CLKREQ1#**	IN	Clock Request pin for SRC1 outputs. If output is selected for control, then that output is controlled as follows: 0 = enabled, 1 = Low-Low
52	GNDCPU	GND	Ground pin for the CPU outputs
53	VDDCPU_IO	PWR	Power supply for differential CPU outputs, nominal 1.05V to 3.3V
54	VDDCPU	PWR	Supply for CPU core, 3.3V nominal
55	CPUKG0C_LPRS	OUT	Complementary signal of low-power differential push-pull AMD K8 "Greyhound" clock with integrated series resistor. (no 33 ohm series resistor needed)
56	CPUKG0T_LPRS	OUT	True signal of low-power differential push-pull AMD K8 "Greyhound" clock with integrated series resistor. (no 33 ohm series resistor needed)
57	PD#	IN	Enter /Exit Power Down. 0 = Power Down, 1 = normal operation.
58	GNDHTT	PWR	Ground pin for the HTT outputs
59	HTT0C_LPRS/66M	OUT	Complementary signal of low-power differential push-pull hypertransport clock with integrated series resistor. (no 50ohm shunt resistor to GND and no 33 ohm series resistor needed) / 1.8V single ended 66MHz hyper transport clock
60	HTT0T_LPRS/66M	OUT	True signal of low-power differential push-pull hypertransport clock with integrated series resistor. (no 50ohm shunt resistor to GND and no 33 ohm series resistor needed) / 1.8V single ended 66MHz hyper transport clock
61	VDDHTT	PWR	Supply for HTT clocks, nominal 3.3V.
62	VDDREF	PWR	Ref, XTAL power supply, nominal 3.3V
63	REF2/SEL_27	OUT	14.318 MHz reference clock, 3.3V/3.3V Latched input to select 27MHz SS and non SS on SRC7 0 = 100MHz differential spreading SRC clock, 1 = 27MHz non-spreading singled clock on pin 4 and 27MHz spread clock on pin 5.
64	REF1/SEL_SATA	I/O	14.318 MHz 3.3V reference clock./ 3.3V tolerant latched input to select function of SRC6/SATA output 0 = 100MHz differential spreading SRC clock, 1 = 100MHz non-spreading differential SATA clock
65	REF0/SEL_HTT66	I/O	14.318 MHz 3.3V reference clock./ 3.3V tolerant latched input to select Hyper Transport Clock Frequency. 0 = 100MHz differential HTT clock, 1 = 66MHz 3.3V single ended HTT clock
66	GNDREF	GND	Ground pin for the REF outputs.
67	X1	IN	Crystal input, nominally 14.318MHz
68	X2	OUT	Crystal output, nominally 14.318MHz
69	VDD48	PWR	Power pin for the 48MHz outputs and core. 3.3V
70	48MHz_1	OUT	48MHz clock output.
71	48MHz_0	OUT	48MHz clock output.
72	GND48	GND	Ground pin for the 48MHz outputs

## General Description

The **ICS9EPRS488** is a main clock synthesizer chip that provides all clocks required for AMD M690T or 780E embedded systems. An SMBus interface allows full control of the device.

## Block Diagram

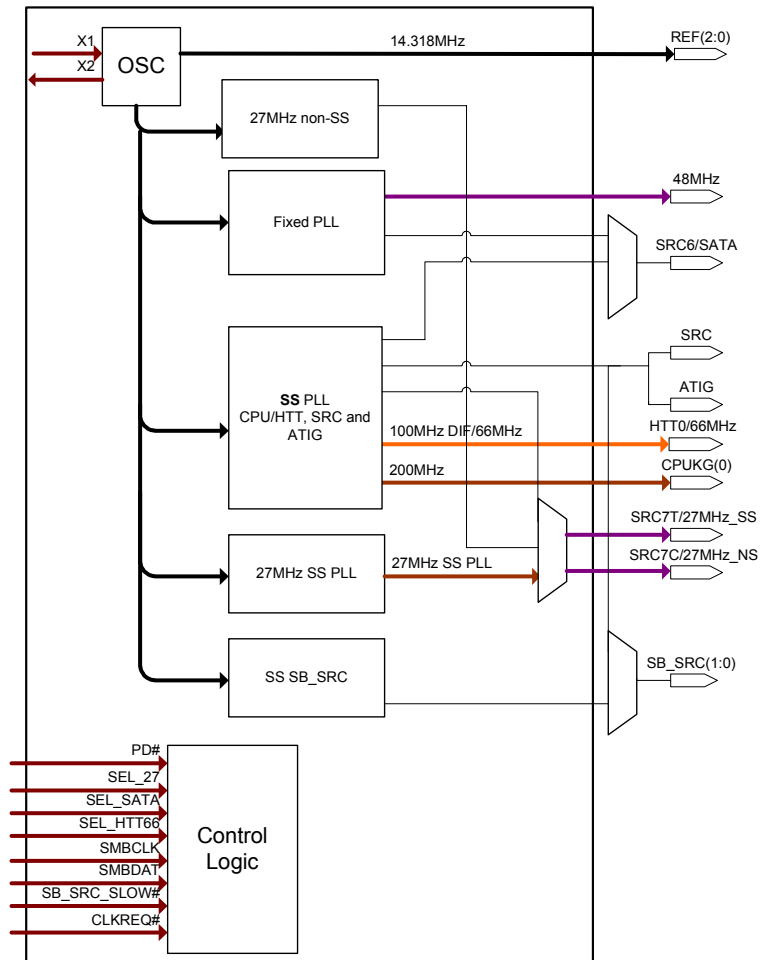

## Power Groups

Pin Number			Description
VDD	VDDIO	GND	
69		72	USB .48 outputs
3		6	SRC/27MHz Outputs
17		11,19	SRC Logic Core
	12,18		SRC differential outputs (IO's)
38		36	SB_SRC Core Logic
	37		SB_SRC differential outputs (IO's)
44		47	SRC/SATA differential output
29		27	ATIG Core Logic
	28		ATIG differential outputs (IO's)
49		48	3.3V Analog
54		52	CPUKG Core Logic
	53		CPUKG differential outputs (IO's)
61		58	HTTCLK output
62		66	REF outputs

Table1: CPU/HTT, SRC and ATIG Frequency Selection Table

Byte 0	Byte 3				CPU (MHz)	HTT Single- ended	Differential HTT	SRC/ATIG	Spread %	CPU OverClock %
Bit0	Bit3	Bit2	Bit1	Bit0		SEL_HTT66 = 1	SEL_HTT66 = 0			
SS_EN	CPU FS3	CPU FS2	CPU FS1	CPU FS0						
0	0	0	0	0	173.63	57.88	86.81	86.81	Off	-13%
0	0	0	0	1	177.17	59.06	88.58	88.58		-11%
0	0	0	1	0	180.78	60.26	90.39	90.39		-10%
0	0	0	1	1	184.47	61.49	92.24	92.24		-8%
0	0	1	0	0	188.24	62.75	94.12	94.12		-6%
0	0	1	0	1	192.08	64.03	96.04	96.04		-4%
0	0	1	1	0	196.00	65.33	98.00	98.00		-2%
<b>0</b>	<b>0</b>	<b>1</b>	<b>1</b>	<b>1</b>	<b>200.00</b>	<b>66.67</b>	<b>100.00</b>	<b>100.00</b>		<b>0%</b>
0	1	0	0	0	204.00	68.00	102.00	102.00		2%
0	1	0	0	1	208.08	69.36	104.04	104.04		4%
0	1	0	1	0	212.24	70.75	106.12	106.12		6%
0	1	0	1	1	216.49	72.16	108.24	108.24		8%
0	1	1	0	0	220.82	73.61	110.41	110.41		10%
0	1	1	0	1	225.23	75.08	112.62	112.62		13%
0	1	1	1	0	229.74	76.58	114.87	114.87		15%
0	1	1	1	1	234.33	78.11	117.17	117.17		17%
1	0	0	0	0	173.63	57.88	86.81	86.81		-0.5%
1	0	0	0	1	175.00	59.06	88.58	88.58	-11%	
1	0	0	1	0	180.78	60.26	90.39	90.39	-10%	
1	0	0	1	1	184.47	61.49	92.24	92.24	-8%	
1	0	1	0	0	188.24	62.75	94.12	94.12	-6%	
1	0	1	0	1	192.08	64.03	96.04	96.04	-4%	
1	0	1	1	0	196.00	65.33	98.00	98.00	-2%	
1	0	1	1	1	<b>200.00</b>	<b>66.67</b>	<b>100.00</b>	<b>100.00</b>	<b>0%</b>	
1	1	0	0	0	204.00	68.00	102.00	102.00	2%	
1	1	0	0	1	208.08	69.36	104.04	104.04	4%	
1	1	0	1	0	212.24	70.75	106.12	106.12	6%	
1	1	0	1	1	216.49	72.16	108.24	108.24	8%	
1	1	1	0	0	220.82	73.61	110.41	110.41	10%	
1	1	1	0	1	225.23	75.08	112.62	112.62	13%	
1	1	1	1	0	229.74	76.58	114.87	114.87	15%	
1	1	1	1	1	234.33	78.11	117.17	117.17	17%	

Table 2: SB\_SRC Frequency Selection Table

Byte 0		Byte 4				SRC (MHz)	Spread %	SB_SRC OverClock %
Bit0	Bit3	Bit2	Bit1	Bit0				
SS_EN	SB FS3	SB FS2	SB FS1	SB FS0				
0	0	0	0	0	80.00	Off	-20%	
0	0	0	0	1	81.25		-19%	
0	0	0	1	0	82.63		-17%	
0	0	0	1	1	84.00		-16%	
0	0	1	0	0	85.25		-15%	
0	0	1	0	1	86.63		-13%	
0	0	1	1	0	88.00		-12%	
0	0	1	1	1	89.25		-11%	
0	1	0	0	0	90.63		-9%	
0	1	0	0	1	92.00		-8%	
0	1	0	1	0	93.25		-7%	
0	1	0	1	1	94.63		-5%	
0	1	1	0	0	96.00		-4%	
0	1	1	0	1	97.25		-3%	
0	1	1	1	0	98.63		-1%	
<b>0</b>	<b>1</b>	<b>1</b>	<b>1</b>	<b>1</b>	<b>100.00</b>		0%	
1	0	0	0	0	80.00		-0.50%	20%
1	0	0	0	1	175.00	-19%		
1	0	0	1	0	82.63	-17%		
1	0	0	1	1	84.00	-16%		
1	0	1	0	0	85.25	-15%		
1	0	1	0	1	86.63	-13%		
1	0	1	1	0	88.00	-12%		
1	0	1	1	1	89.25	-11%		
1	1	0	0	0	90.63	-9%		
1	1	0	0	1	92.00	-8%		
1	1	0	1	0	93.25	-7%		
1	1	0	1	1	94.63	-5%		
1	1	1	0	0	96.00	-4%		
1	1	1	0	1	97.25	-3%		
1	1	1	1	0	98.63	-1%		
1	1	1	1	1	100.00	0%		

**Table 3: 27Mhz\_Spread and Frequency Selection Table**

SS Enable B2b1	SS3	SS2	SS1	SS0	27MHz_Spread (MHz)	Spread	
	Byte 4 bit 7	Byte 4 bit 6	Byte 4 bit 5	Byte 4 bit 4		% (when enabled)	
0	0	0	0	0	27.00	No Spread	
0	0	0	0	1	27.00		
0	0	0	1	0	27.00		
0	0	0	1	1	27.00		
0	0	1	0	0	27.00		
0	0	1	0	1	27.00		
0	0	1	1	0	27.00		
0	0	1	1	1	27.00		
0	1	0	0	0	27.00		
0	1	0	0	1	27.00		
0	1	0	1	0	27.00		
0	1	0	1	1	27.00		
0	1	1	0	0	27.00		
0	1	1	0	1	27.00		
0	1	1	1	0	27.00		
0	1	1	1	1	27.00		
1	0	0	0	0	27.00	-0.50	Down
1	0	0	0	1	27.00	-1.00	Down
1	0	0	1	0	175.00	-1.50	Down
1	0	0	1	1	27.00	-2.00	Down
1	0	1	0	0	27.00	-0.75	Down
1	0	1	0	1	27.00	-1.25	Down
1	0	1	1	0	27.00	-1.75	Down
1	0	1	1	1	27.00	-2.25	Down
1	1	0	0	0	27.00	+/-0.25	Center
1	1	0	0	1	27.00	+/-0.5	Center
1	1	0	1	0	27.00	+/-0.75	Center
1	1	0	1	1	27.00	+/-1.0	Center
1	1	1	0	0	27.00	+/-0.25	Center
1	1	1	0	1	27.00	+/-0.5	Center
1	1	1	1	0	27.00	+/-0.75	Center
1	1	1	1	1	27.00	+/-1.0	Center

**Table 4: CPU Divider Ratios**

		Divider (3:2)							
Divider (1:0)	Bit	00		01		10		11	MSB
	00	0000	2	0100	4	1000	8	1100	16
	01	<b>0001</b>	<b>3</b>	0101	6	1001	12	1101	24
	10	0010	5	0110	10	1010	20	1110	40
	11	0011	15	0111	30	1011	60	1111	120
	<b>LSB</b>	Address	Div	Address		Address	Div	Address	Div

**Table 5: SRC, SB\_SRC, ATIG Divider Ratios**

		Divider (3:2)							
Divider (1:0)	Bit	00		01		10		11	MSB
	00	0000	2	0100	4	1000	8	1100	16
	01	0001	3	<b>0101</b>	<b>6</b>	1001	12	1101	24
	10	0010	5	0110	10	1010	20	1110	40
	11	0011	15	0111	14	1011	28	1111	56
	<b>LSB</b>	Address	Div	Address		Address	Div	Address	Div

**Differential Output Power Management Table**

PD#	CLKREQ#	SMBus Register OE	True output	Complement Output	True output	Complement Output
			Free-Run		CLKREQ# Selected	
1	<b>0</b>	Enable	Running	Running	Running	Running
<b>0</b>	X	X	Low/20K	Low	Low/20K	Low
1	<b>1</b>	Enable	Running	Running	Low/20K	Low
X	X	<b>Disable</b>	Low/20K	Low	Low/20K	Low

Note: 20K means 20Kohm Pull Down

**Singled-ended Power Management Table**

PD#	SMBus Register OE	48MHz	27MHz	HTT66MHz	REF(2:0)
1	Enable	Running	Running	Running	Running
0	Enable	Low	Low	Low	Hi-Z

## Absolute Max

PARAMETER	SYMBOL	CONDITIONS	MIN	TYP	MAX	UNITS	Notes
3.3V Supply Voltage	VDDxxx	-		3.3	GND + 3.9V	V	1
Storage Temperature	Ts	-	-65		150	°C	1
Ambient Operating Temp	Tambient	-	0		70	°C	1
Case Temperature	Tcase	-			115	°C	1
Input ESD protection HBM	ESD prot	-	2000			V	1

<sup>1</sup>Guaranteed by design and characterization, not 100% tested in production.

## Electrical Characteristics - Input/Supply/Common Output Parameters

PARAMETER	SYMBOL	CONDITIONS*	MIN	TYP	MAX	UNITS	Notes
3.3V Core Supply Voltage	VDDxxx	-	3.135	3.3	3.465	V	1
Input High Voltage	V <sub>IH</sub>	VDD = 3.3 V +/-5%	2		V <sub>DD</sub> + 0.3	V	1
Input Low Voltage	V <sub>IL</sub>	VDD = 3.3 V +/-5%	V <sub>SS</sub> - 0.3		0.8	V	1
Input High Current	I <sub>IH</sub>	V <sub>IN</sub> = V <sub>DD</sub>	-5		5	uA	1
Input Low Current	I <sub>IL1</sub>	V <sub>IN</sub> = 0 V; Inputs with no pull-up resistors	-5			uA	1
	I <sub>IL2</sub>	V <sub>IN</sub> = 0 V; Inputs with pull-up resistors	-200			uA	1
Low Threshold Input-High Voltage	V <sub>IH_FS</sub>	VDD = 3.3 V +/-5%	0.7		V <sub>DD</sub> + 0.3	V	1
Low Threshold Input-Low Voltage	V <sub>IL_FS</sub>	VDD = 3.3 V +/-5%	V <sub>SS</sub> - 0.3		0.35	V	1
Operating Current	I <sub>DD3.3OP</sub>	3.3V VDD current, all outputs driven			175	mA	1
Powerdown Current	I <sub>DD3.3PD</sub>	all diff pairs low/low			2	mA	1
Input Frequency	F <sub>i</sub>	VDD = 3.3 V +/-5%		14.31818		MHz	2
Pin Inductance	L <sub>pin</sub>				7	nH	1
Input Capacitance	C <sub>IN</sub>	Logic Inputs			5	pF	1
	C <sub>OUT</sub>	Output pin capacitance			6	pF	1
	C <sub>INX</sub>	X1 & X2 pins			5	pF	1
Clk Stabilization	T <sub>STAB</sub>	From VDD Power-Up or de-assertion of PD to 1st clock			3	ms	1
Modulation Frequency		Triangular Modulation	30		33	kHz	1
Tdrive_PD		CPU output enable after PD de-assertion			300	us	1
Tfall_PD		PD fall time of			5	ns	1
Trise_PD		PD rise time of			5	ns	1
SMBus Voltage	V <sub>DDSMB</sub>		2.7		5.5	V	1
Low-level Output Voltage	V <sub>OLSMB</sub>	@ I <sub>PULLUP</sub>			0.4	V	1
Current sinking at V <sub>OL</sub> = 0.4 V	I <sub>PULLUPSMB</sub>		4	6		mA	1
SMBCLK/SMBDAT Clock/Data Rise Time	T <sub>RSMB</sub>	(Max V <sub>IL</sub> - 0.15) to (Min V <sub>IH</sub> + 0.15)			1000	ns	1
SMBCLK/SMBDAT Clock/Data Fall Time	T <sub>FSMB</sub>	(Min V <sub>IH</sub> + 0.15) to (Max V <sub>IL</sub> - 0.15)			300	ns	1

\*TA = 0 - 70°C; Supply Voltage VDD = 3.3 V +/-5%

<sup>1</sup>Guaranteed by design and characterization, not 100% tested in production.

<sup>2</sup> Input frequency should be measured at the REF pin and tuned to ideal 14.31818MHz to meet ppm frequency accuracy on PLL outputs.

### AC Electrical Characteristics - Low-Power DIF Outputs: CPUKG and HTT

PARAMETER	SYMBOL	CONDITIONS	MIN	TYP	MAX	UNITS	NOTES
Crossing Point Variation	$\Delta V_{\text{CROSS}}$	Single-ended Measurement			140	mV	1,2,5
Frequency - CPU	$f_{\text{CPU}}$	Spread Specturm On	198.8		200	MHz	1,3
Frequency - HTT	$f_{\text{HTT}}$	Spread Specturm On	99.4		100	MHz	1,3
Long Term Accuracy	ppm	Spread Specturm Off	-300		+300	ppm	1,11
Rising Edge Slew Rate	$S_{\text{RISE}}$	Differential Measurement	0.5		10	V/ns	1,4
Falling Edge Slew Rate	$S_{\text{FALL}}$	Differential Measurement	0.5		10	V/ns	1,4
Slew Rate Variation	$t_{\text{SLVAR}}$	Single-ended Measurement			20	%	1
CPU, DIF HTT Jitter - Cycle to Cycle	$\text{CPUJ}_{\text{C2C}}$	Differential Measurement			150	ps	1,6
Accumulated Jitter	$t_{\text{JACC}}$	See Notes			1	ns	1,7
Peak to Peak Differential Voltage	$V_{\text{D(PK-PK)}}$	Differential Measurement	400		2400	mV	1,8
Differential Voltage	$V_{\text{D}}$	Differential Measurement	200		1200	mV	1,9
Duty Cycle	$D_{\text{CYC}}$	Differential Measurement	45		55	%	1
Amplitude Variation	$\Delta V_{\text{D}}$	Change in $V_{\text{D}}$ DC cycle to cycle	-75		75	mV	1,10
CPU[1:0] Skew	$\text{CPU}_{\text{SKEW10}}$	Differential Measurement			100	ps	1

#### Notes on Electrical Characteristics:

<sup>1</sup>Guaranteed by design and characterization, not 100% tested in production.

<sup>2</sup>Single-ended measurement at crossing point. Value is maximum – minimum over all time. DC value of common mode is not

<sup>3</sup>Minimum Frequency is a result of 0.5% down spread spectrum

<sup>4</sup>Differential measurement through the range of  $\pm 100$  mV, differential signal must remain monotonic and within slew rate spec when crossing through this region.

<sup>5</sup>Defined as the total variation of all crossing voltages of CLK rising and CLK# falling. Matching applies to rising edge rate of CLK and falling edge of CLK#. It is measured using a  $\pm 75$ mV window centered on the average cross point where CLK meets CLK#.

<sup>6</sup>Max difference of  $t_{\text{CYCLE}}$  between any two adjacent cycles.

<sup>7</sup>Accumulated  $t_{\text{jc}}$  over a 10  $\mu$ s time period, measured with JIT2 TIE at 50ps interval.

<sup>8</sup> $V_{\text{D(PK-PK)}}$  is the overall magnitude of the differential signal.

<sup>9</sup> $V_{\text{D(min)}}$  is the amplitude of the ring-back differential measurement, guaranteed by design, that ring-back will not cross 0V  $V_{\text{D}}$ .  $V_{\text{D(max)}}$  is the largest amplitude allowed.

<sup>10</sup>The difference in magnitude of two adjacent  $V_{\text{D\_DC}}$  measurements.  $V_{\text{D\_DC}}$  is the stable post overshoot and ring-back part of

<sup>11</sup>All Long Term Accuracy and Clock Period specifications are guaranteed assuming that REFOUT is at 14.31818MHz

### AC Electrical Characteristics - Low-Power DIF Outputs: SRC, SB\_SRC and ATIG

PARAMETER	SYMBOL	CONDITIONS	MIN	TYP	MAX	UNITS	NOTES
Rising Edge Slew Rate	$t_{SLR}$	Differential Measurement	0.6		4	V/ns	1,2
Falling Edge Slew Rate	$t_{FLR}$	Differential Measurement	0.6		4	V/ns	1,2
Slew Rate Variation	$t_{SLVAR}$	Single-ended Measurement			20	%	1
Maximum Output Voltage	$V_{HIGH}$	Includes overshoot			1150	mV	1
Minimum Output Voltage	$V_{LOW}$	Includes undershoot	-300			mV	1
Differential Voltage Swing	$V_{SWING}$	Differential Measurement	300			mV	1
Crossing Point Voltage	$V_{XABS}$	Single-ended Measurement	300		550	mV	1,3,4
Crossing Point Variation	$V_{XABSVAR}$	Single-ended Measurement			140	mV	1,3,5
Duty Cycle	$D_{CYC}$	Differential Measurement	45		55	%	1
SRC, ATIG, Jitter - Cycle to Cycle	$SRC_{C2C}$	Differential Measurement			125	ps	1
SRC[5:0] Skew	$SRC_{SKEW}$	Differential Measurement			250	ps	1
SB_SRC[1:0] Skew	$SRC_{SKEW}$	Differential Measurement			100	ps	1
ATIG[2:0] Skew	$SRC_{SKEW}$	Differential Measurement			100	ps	1

#### Notes on Electrical Characteristics:

- <sup>1</sup>Guaranteed by design and characterization, not 100% tested in production.
- <sup>2</sup>Slew rate measured through  $V_{swing}$  centered around differential zero
- <sup>3</sup> $V_{xabs}$  is defined as the voltage where  $CLK = CLK\#$
- <sup>4</sup>Only applies to the differential rising edge (CLK rising and CLK# falling)
- <sup>5</sup>Defined as the total variation of all crossing voltages of CLK rising and CLK# falling. Matching applies to rising edge rate of
- <sup>6</sup>All Long Term Accuracy and Clock Period specifications are guaranteed assuming that REFOUT is at 14.31818MHz

### Electrical Characteristics - Single-ended HTT 66MHz Clock

PARAMETER	SYMBOL	CONDITIONS	MIN	TYP	MAX	UNITS	Notes
Long Accuracy	ppm	see Tperiod min-max values	-100		100	ppm	1,2
HTT66 Clock period	$T_{period}$	66.67MHz output nominal	14.9955		15.0045	ns	2
		66.67MHz output spread	14.9955		15.0799	ns	2
Output High Voltage	$V_{OH}$	$I_{OH} = -1\text{ mA}$	1.6	1.8	3.3	V	1
Output Low Voltage	$V_{OL}$	$I_{OL} = 1\text{ mA}$		0	0.2	V	1
Rise Time	$t_{r1}$	$V_{OL} = 0.36\text{ V}, V_{OH} = 1.44\text{ V}$			1.5	ns	1
Fall Time	$t_{f1}$	$V_{OH} = 1.44\text{ V}, V_{OL} = 0.36\text{ V}$			1.5	ns	1
Duty Cycle	$d_{t1}$	$V_T = 0.9\text{ V}$	45		55	%	1
Jitter, Cycle to cycle	$t_{jyc-cyc}$	$V_T = 0.9\text{ V}$			300	ps	1
Jitter, Long Term	$t_{LTJ}$	$V_T = 0.9\text{ V}$			1	ns	1

\*TA = 0 - 70°C; Supply Voltage VDD = 3.3 V +/-5%, CL = 5 pF with  $R_s = 22\Omega$  (unless otherwise specified)

- <sup>1</sup>Guaranteed by design and characterization, not 100% tested in production.
- <sup>2</sup>All Long Term Accuracy and Clock Period specifications are guaranteed with the assumption that REF is at 14.31818MHz

### Electrical Characteristics - USB - 48MHz

PARAMETER	SYMBOL	CONDITIONS*	MIN	TYP	MAX	UNITS	NOTES
Long Accuracy	ppm	see Tperiod min-max values	-100	0	100	ppm	1,2
Clock period	T <sub>period</sub>	48.00MHz output nominal	20.8229		20.8344	ns	2
Clock Low Time	T <sub>low</sub>	Measure from < 0.6V	9.3750		11.4580	ns	2
Clock High Time	T <sub>high</sub>	Measure from > 2.0V	9.3750		11.4580	ns	2
Output High Voltage	V <sub>OH</sub>	I <sub>OH</sub> = -1 mA	2.4			V	1
Output Low Voltage	V <sub>OL</sub>	I <sub>OL</sub> = 1 mA			0.55	V	1
Output High Current	I <sub>OH</sub>	V <sub>OH</sub> @ MIN = 1.0 V	-33			mA	1
		V <sub>OH</sub> @ MAX = 3.135 V			-33	mA	1
Output Low Current	I <sub>OL</sub>	V <sub>OL</sub> @ MIN = 1.95 V	30			mA	1
		V <sub>OL</sub> @ MAX = 0.4 V			38	mA	1
Rise Time	t <sub>r_USB</sub>	V <sub>OL</sub> = 0.4 V, V <sub>OH</sub> = 2.4 V	0.5		1.5	ns	1
Fall Time	t <sub>f_USB</sub>	V <sub>OH</sub> = 2.4 V, V <sub>OL</sub> = 0.4 V	0.5		1.5	ns	1
Duty Cycle	d <sub>t1</sub>	V <sub>T</sub> = 1.5 V	45		55	%	1
Group Skew	t <sub>skew</sub>	V <sub>T</sub> = 1.5 V			250	ps	1
Jitter, Cycle to cycle	t <sub>jcy-cyc</sub>	V <sub>T</sub> = 1.5 V			130	ps	1,2

\*TA = 0 - 70°C; Supply Voltage VDD = 3.3 V +/-5%, CL = 5 pF with Rs = 22Ω (unless otherwise specified)

<sup>1</sup>Guaranteed by design and characterization, not 100% tested in production.

<sup>2</sup>ICS recommended and/or chipset vendor layout guidelines must be followed to meet this specification

### Electrical Characteristics - 27MHz

PARAMETER	SYMBOL	CONDITIONS	MIN	TYP	MAX	UNITS	Notes
Long Accuracy	ppm	see Tperiod min-max values	-50		50	ppm	1,2
			-15		15		1,2,3
Clock period	T <sub>period</sub>	27.000MHz output nominal	37.0365		37.0376	ns	2
Output High Voltage(27SS)	V <sub>OH</sub>	I <sub>OH</sub> = -1 mA	2.1			V	1,10
Output High Voltage (27NSS)	V <sub>OH</sub>	I <sub>OH</sub> = -1 mA	0.8			V	1,11
Output Low Voltage	V <sub>OL</sub>	I <sub>OL</sub> = 1 mA			0.55	V	1
Output High Current	I <sub>OH</sub>	V <sub>OH</sub> = 1.0 V	-29			mA	1,10
		V <sub>OH</sub> = 3.135 V			-23	mA	1,10
Output Low Current	I <sub>OL</sub>	V <sub>OL</sub> = 1.95 V	29			mA	1,10
		V <sub>OL</sub> = 0.4 V			27	mA	1,10
Edge Rate	t <sub>slewr/f</sub>	Rising/Falling edge rate V <sub>T</sub> @ 20%-80%	1	2	4	V/ns	1
Duty Cycle	d <sub>t1</sub>	V <sub>T</sub> = 1.5 V	45		55	%	1
Jitter	t <sub>ltj</sub>	Long Term (10us)			300	ps	1
	t <sub>jcy-cyc</sub>	V <sub>T</sub> = 1.5 V			200	ps	1

<sup>1</sup>Guaranteed by design and characterization, not 100% tested in production.

<sup>2</sup>Slew rate measured through Vswing centered around differential zero

<sup>3</sup>Vxabs is defined as the voltage where CLK = CLK#

<sup>10</sup>V<sub>DD</sub> = 3.3V

<sup>11</sup>V<sub>DD</sub> = 1.1V

### Electrical Characteristics - REF-14.318MHz

PARAMETER	SYMBOL	CONDITIONS	MIN	TYP	MAX	UNITS	Notes
Long Accuracy	ppm	see Tperiod min-max values	-100		100	ppm	1,2
Clock period	T <sub>period</sub>	14.318MHz output nominal	69.8270		69.8550	ns	2
Clock Low Time	T <sub>low</sub>	Measure from < 0.6V	30.9290		37.9130	ns	2
Clock High Time	T <sub>high</sub>	Measure from > 2.0V	30.9290		37.9130	ns	2
Output High Voltage	V <sub>OH</sub>	I <sub>OH</sub> = -1 mA	2.4			V	1
Output Low Voltage	V <sub>OL</sub>	I <sub>OL</sub> = 1 mA			0.4	V	1
Output High Current	I <sub>OH</sub>	V <sub>OH</sub> @MIN = 1.0 V, V <sub>OH</sub> @MAX = 3.135 V	-29		-23	mA	1
Output Low Current	I <sub>OL</sub>	V <sub>OL</sub> @MIN = 1.95 V, V <sub>OL</sub> @MAX = 0.4 V	29		27	mA	1
Rise Time	t <sub>r1</sub>	V <sub>OL</sub> = 0.4 V, V <sub>OH</sub> = 2.4 V	1		1.5	ns	1
Fall Time	t <sub>f1</sub>	V <sub>OH</sub> = 2.4 V, V <sub>OL</sub> = 0.4 V	1		1.5	ns	1
Skew	t <sub>sk1</sub>	V <sub>T</sub> = 1.5 V			250	ps	1
Duty Cycle	d <sub>t1</sub>	V <sub>T</sub> = 1.5 V	45		55	%	1
Jitter	t <sub>jvc-cyc</sub>	V <sub>T</sub> = 1.5 V			200	ps	1

\*TA = 0 - 70°C; Supply Voltage VDD = 3.3 V +/-5%, CL = 5 pF with R<sub>s</sub> = 22Ω (unless otherwise specified)

<sup>1</sup>Guaranteed by design and characterization, not 100% tested in production.

<sup>2</sup>All Long Term Accuracy and Clock Period specifications are guaranteed assuming that REFOUT is at 14.31818MHz

## General SMBus serial interface information for the ICS9EPRS488

### How to Write:

- Controller (host) sends a start bit.
- Controller (host) sends the write address  $D2_{(H)}$
- ICS clock will **acknowledge**
- Controller (host) sends the beginning byte location = N
- ICS clock will **acknowledge**
- Controller (host) sends the data byte count = X
- ICS clock will **acknowledge**
- Controller (host) starts sending **Byte N through Byte N + X - 1**
- ICS clock will **acknowledge** each byte **one at a time**
- Controller (host) sends a Stop bit

### How to Read:

- Controller (host) will send start bit.
- Controller (host) sends the write address  $D2_{(H)}$
- ICS clock will **acknowledge**
- Controller (host) sends the beginning byte location = N
- ICS clock will **acknowledge**
- Controller (host) will send a separate start bit.
- Controller (host) sends the read address  $D3_{(H)}$
- ICS clock will **acknowledge**
- ICS clock will send the data byte count = X
- ICS clock sends **Byte N + X - 1**
- ICS clock sends **Byte 0 through byte X (if  $X_{(H)}$  was written to byte 8).**
- Controller (host) will need to acknowledge each byte
- Controller (host) will send a not acknowledge bit
- Controller (host) will send a stop bit

Index Block Write Operation		
Controller (Host)		ICS (Slave/Receiver)
T	starT bit	
Slave Address $D2_{(H)}$		
WR	WRite	
		ACK
Beginning Byte = N		
		ACK
Data Byte Count = X		
		ACK
Beginning Byte N		X Byte
	○	
	○	
	○	
	○	
Byte N + X - 1		
		ACK
P	stoP bit	

Index Block Read Operation			
Controller (Host)		ICS (Slave/Receiver)	
T	starT bit		
Slave Address $D2_{(H)}$			
WR	WRite		
		ACK	
Beginning Byte = N			
		ACK	
RT	Repeat starT		
Slave Address $D3_{(H)}$			
RD	ReaD		
		ACK	
		Data Byte Count = X	
ACK			
ACK		X Byte	
			Beginning Byte N
○			
○			
○			
		Byte N + X - 1	
N	Not acknowledge		
P	stoP bit		

**SMBus Table: Latched Input Readback Output Enable Control Register**

Byte	0	Name	Description	Type	0	1	Default
	Bit 7	SEL_HTT66 readback	Hypertransport Select	R	100MHz Differential HTT clock	66 MHz 3.3V Single-ended HTT clock	Latch
	Bit 6	SEL_SATA readback	SATA Select	R	SRC6/SATA pair is SRC SS capable output	SRC6/SATA pair is SATA non-spread output	Latch
	Bit 5	REF0_OE	Output Enable	RW	Hi-Z	Enabled	1
	Bit 4	REF1_OE	Output Enable	RW	Hi-Z	Enabled	1
	Bit 3	REF2_OE	Output Enable	RW	Hi-Z	Enabled	1
	Bit 2	48MHz_1_OE	Output Enable	RW	Low	Enabled	1
	Bit 1	48MHz_0_OE	Output Enable	RW	Low	Enabled	1
	Bit 0	SS_Enable	Spread Spectrum Enable (CPU, SRC, SB_SRC, ATIG)	RW	Spread Off	Spread On	0

**SMBus Table: Output Enable Control Register**

Byte	1	Name	Control Function	Type	0	1	Default
	Bit 7	SRC7/27MHz_OE	Output Enable	RW	Low/Low	Enabled	1
	Bit 6	SRC6/SATA_OE Enable	Output Enable	RW	Low/Low	Enabled	1
	Bit 5	SRC5_OE	Output Enable	RW	Low/Low	Enabled	1
	Bit 4	SRC4_OE	Output Enable	RW	Low/Low	Enabled	1
	Bit 3	SRC3_OE	Output Enable	RW	Low/Low	Enabled	1
	Bit 2	SRC2_OE	Output Enable	RW	Low/Low	Enabled	1
	Bit 1	SRC1_OE	Output Enable	RW	Low/Low	Enabled	1
	Bit 0	SRC0_OE	Output Enable	RW	Low/Low	Enabled	1

**SMBus Table: Output Enable and 48MHz Slew Rate Control Register**

Byte	2	Name	Control Function	Type	0	1	Default
	Bit 7	SB_SRC1_OE	Output Enable	RW	Low/Low	Enabled	1
	Bit 6	SB_SRC0_OE	Output Enable	RW	Low/Low	Enabled	1
	Bit 5	48MHz_0_Slew Rate	Slew Rate Control	RW	These bits program the slew rate of the single ended outputs. The maximum slew rate is 1.9V/ns and the minimum slew rate is 1.1V/ns. The slew rate selection is as follows: 11 = 1.9V/ns 10 = 1.6V/ns 01 = 1.1V/ns 00 = tristated		1
	Bit 4						1
	Bit 3	ATIG1_OE	Output Enable	RW	Low/Low	Enabled	1
	Bit 2	ATIG0_OE	Output Enable	RW	Low/Low	Enabled	1
	Bit 1	27MHz_SS_Enable	Spread Spectrum Enable 27MHz_SS	RW	Spread Off	Spread On	0
	Bit 0	Reserved	Reserved	RW	-	-	X

**SMBus Table: CPU/HTT Frequency Control Register**

Byte	3	Name	Control Function	Type	0	1	Default
	Bit 7	CPU0_OE	Output enable	RW	Low/Low	Enable	1
	Bit 6	SEL_27 readback	SRC7/27MHz Select	R	SRC7 Output	27MHz Output	Latch
	Bit 5	ATIG2_OE	Output Enable	RW	Low/Low	Enabled	1
	Bit 4	HTT/66MHz_OE	Output Enable	RW	Low/Low	Enabled	1
	Bit 3	CPU_FS3	CPU Frequency Select	RW	See CPU/HTT/SRC/ATIG Frequency Select Table Default value corresponds to 200MHz. Note that the HTT frequency tracks the CPU frequency.		0
	Bit 2	CPU_FS2	CPU Frequency Select	RW			1
	Bit 1	CPU_FS1	CPU Frequency Select	RW			1
	Bit 0	CPU_FS0	CPU Frequency Select LSB	RW			1

**SMBus Table: SB\_SRC Frequency Control Register**

Byte	4	Name	Control Function	Type	0	1	Default
Bit 7		S3	27_SSC Spread Select	RW	S[1:0]: 00 = -0.5% Default, 01 = 1.0%, 10 = -1.5%, 11 = -2%. See Table 3: 27Mhz_Spread, LCDCLK Spread and Frequency Selection Table for additional selections.		0
Bit 6		S2		RW			0
Bit 5		S1		RW			0
Bit 4		S0		RW			0
Bit 3		SB_SRC_FS3	SB_SRC Frequency Select	RW	See SB_SRC Frequency Select Table.		1
Bit 2		SB_SRC_FS2	SB_SRC Frequency Select	RW			1
Bit 1		SB_SRC_FS1	SB_SRC Frequency Select	RW			1
Bit 0		SB_SRC_FS0	SB_SRC Freq. Select LSB	RW			1

**SMBus Table: 27MHz Slew Rate Control Register**

Byte	5	Name	Control Function	Type	0	1	Default
Bit 7		27M_SS_Slew Rate	Slew Rate Control	RW	These bits program the slew rate of the single ended outputs. The maximum slew rate is 1.9V/ns and the minimum slew rate is 1.1V/ns. The slew rate selection is as follows: 11 = 1.9V/ns 10 = 1.6V/ns 01 = 1.1V/ns 00 = tristated		1
Bit 6							1
Bit 5		27M_NS_Slew Rate	Slew Rate Control	RW			1
Bit 4							1
Bit 3		SB_SRC Source	SB_SRC Source Selection	RW	SB_SRC PLL	SRC PLL	1
Bit 2		Reserved					0
Bit 1		Reserved					0
Bit 0		Reserved					0

**SMBus Table: I/O Vout Control Register**

Byte	6	Name	Control Function	Type	0	1	Default
Bit 7		SRC Diff AMP	SRC Differential output	RW	00 = 700mV	01 = 800mV	0
Bit 6		SRC Diff AMP	Amplitude Control	RW	10 = 900mV	11 = 1000mV	1
Bit 5		CPU Diff AMP	CPU Differential output	RW	00 = 700mV	01 = 800mV	0
Bit 4		CPU Diff AMP	Amplitude Control	RW	10 = 900mV	11 = 1000mV	1
Bit 3		SB_SRC Diff AMP	SB_SRC Differential output	RW	00 = 700mV	01 = 800mV	0
Bit 2		SB_SRC Diff AMP	Amplitude Control	RW	10 = 900mV	11 = 1000mV	1
Bit 1		Reserved					X
Bit 0		Reserved					X

**SMBus Table: Vendor & Revision ID Register**

Byte	7	Name	Control Function	Type	0	1	Default
Bit 7		RID3	REVISION ID	R	-	-	0
Bit 6		RID2		R	-	-	1
Bit 5		RID1		R	-	-	0
Bit 4		RID0		R	-	-	0
Bit 3		VID3	VENDOR ID	R	-	-	0
Bit 2		VID2		R	-	-	0
Bit 1		VID1		R	-	-	0
Bit 0		VID0		R	-	-	1

**SMBus Table: Byte Count Register**

Byte	8	Name	Control Function	Type	0	1	Default
Bit 7		Reserved					0
Bit 6		Reserved					0
Bit 5		BC5	Byte Count bit 5 (MSB)	RW	Determines the number of bytes that are read back from the device. Default is 0F hex.		0
Bit 4		BC4	Byte Count bit 4	RW		0	
Bit 3		BC3	Byte Count bit 3	RW		1	
Bit 2		BC2	Byte Count bit 2	RW		1	
Bit 1		BC1	Byte Count bit 1	RW		1	
Bit 0		BC0	Byte Count bit 0 (LSB)	RW		1	

**SMBus Table: WatchDog Timer Control Register**

Byte	9	Name	Control Function	Type	0	1	Default
Bit 7		HWD_EN	Watchdog Hard Alarm Enable	RW	Disable and Reload Hard Alarm Timer, Clear WD Hard status bit.	Enable Timer	0
Bit 6		SWD_EN	Watchdog Soft Alarm Enable	RW	Disable	Enable	0
Bit 5		WD Hard Status	WD Hard Alarm Status	R	Normal	Alarm	X
Bit 4		WD Soft Status	WD Soft Alarm Status	R	Normal	Alarm	X
Bit 3		WDTCtrl	Watch Dog Alarm Time base Control	RW	290ms Base	1160ms Base	0
Bit 2		HWD2	WD Hard Alarm Timer Bit 2	RW	These bits represent the number of Watch Dog Time Base Units that pass before the Watch Alarm expires. Default is 7 X 290ms = 2s.		1
Bit 1		HWD1	WD Hard Alarm Timer Bit 1	RW			1
Bit 0		HWD0	WD Hard Alarm Timer Bit 0	RW			1

**SMBus Table: WD Timer Safe Frequency Control Register**

Byte	10	Name	Control Function	Type	0	1	Default
Bit 7		SWD2	WD Soft Alarm Timer Bit 2	RW	These bits represent the number of Watch Dog Time Base Units that pass before the Watch Alarm expires. Default is 7 X 290ms = 2s.		1
Bit 6		SWD1	WD Soft Alarm Timer Bit 1	RW			1
Bit 5		SWD0	WD Soft Alarm Timer Bit 0	RW			1
Bit 4		WD SF4	Watch Dog Safe Freq Programming bits	RW	These bits configure the safe frequency that the device returns to if the Watchdog Timer expires. The value show here corresponds to the power up default of the device. See the various Frequency Select Tables for the exact frequencies.		0
Bit 3		WD SF3		RW			0
Bit 2		WD SF2		RW			1
Bit 1		WD SF1		RW			1
Bit 0		WD SF0		RW			1

**SMBus Table: CPU PLL Frequency Control Register**

Byte	11	Name	Control Function	Type	0	1	Default
Bit 7		N Div2	N Divider Prog bit 2	RW	The decimal representation of M and N Divider in Byte 11 and 12 will configure the VCO frequency. Default at power up = Byte 3 Rom table. VCO Frequency = 14.318 x Ndiv(10:0)/Mdiv(5:0) .		X
Bit 6		N Div1	N Divider Prog bit 1	RW			X
Bit 5		M Div5	M Divider Programming bits	RW			X
Bit 4		M Div4		RW			X
Bit 3		M Div3		RW			X
Bit 2		M Div2		RW			X
Bit 1		M Div1		RW			X
Bit 0		M Div0		RW			X

**SMBus Table: CPU PLL Frequency Control Register**

Byte	12	Name	Control Function	Type	0	1	Default
Bit 7		N Div10	N Divider Programming b(10:3)	RW	The decimal representation of M and N Divider in Byte 11 and 12 will configure the VCO frequency. Default at power up = Byte 3 Rom table. VCO Frequency = 14.318 x Ndiv(10:0)/Mdiv(5:0) .		X
Bit 6		N Div9		RW			X
Bit 5		N Div8		RW			X
Bit 4		N Div7		RW			X
Bit 3		N Div6		RW			X
Bit 2		N Div5		RW			X
Bit 1		N Div4		RW			X
Bit 0		N Div3		RW			X

**SMBus Table: CPU PLL Spread Spectrum Control Register**

Byte	13	Name	Control Function	Type	0	1	Default
Bit 7		SSP7	Spread Spectrum Programming b(7:0)	RW	Bytes 13 and 14 set the CPU/HTT/SRC/ATIG spread percentage.Please contact ICS for the appropriate values.		X
Bit 6		SSP6		RW			X
Bit 5		SSP5		RW			X
Bit 4		SSP4		RW			X
Bit 3		SSP3		RW			X
Bit 2		SSP2		RW			X
Bit 1		SSP1		RW			X
Bit 0		SSP0		RW			X

**SMBus Table: CPU PLL Spread Spectrum Control Register**

Byte	14	Name	Control Function	Type	0	1	Default
Bit 7		Reserved					X
Bit 6		SSP14	Spread Spectrum Programming b(14:8)	RW	Bytes 13 and 14 set the CPU/HTT/SRC/ATIG spread percentage.Please contact ICS for the appropriate values.		X
Bit 5		SSP13		RW			X
Bit 4		SSP12		RW			X
Bit 3		SSP11		RW			X
Bit 2		SSP10		RW			X
Bit 1		SSP9		RW			X
Bit 0		SSP8		RW			X

**SMBUS Table: CPU Output Divider Register**

Byte	15	Name	Control Function	Type	0	1	Default
Bit 7		CPU NDiv0	LSB N Divider Programming	RW	CPU M/N programming.		X
Bit 6		Reserved					X
Bit 5		Reserved					X
Bit 4		Reserved					X
Bit 3		CPUDiv3	CPU Divider Ratio Programming Bits	RW	0000:/2 ; 0100:/4	1000:/8 ; 1100:/16	X
Bit 2		CPUDiv2		RW	0001:/3 ; 0101:/6	1001:/12 ; 1101:/24	X
Bit 1		CPUDiv1		RW	0010:/5 ; 0110:/10	1010:/20 ; 1110:/40	X
Bit 0		CPUDiv0		RW	0011:/15 ; 0111:/18	1011:/36 ; 1111:/72	X

**SMBUS Table: SB\_SRC Frequency Control Register**

Byte	16	Name	Control Function	Type	0	1	Default
Bit 7		N Div2	N Divider Prog bit 2	RW	The decimal representation of M and N Divider in Byte 16 and 17 configure the SB_SRC VCO frequency. See M/N Calculation Tables for VCO frequency formulas.		X
Bit 6		N Div1	N Divider Prog bit 1	RW			X
Bit 5		M Div5	M Divider Programming bit (5:0)	RW			X
Bit 4		M Div4		RW			X
Bit 3		M Div3		RW			X
Bit 2		M Div2		RW			X
Bit 1		M Div1		RW			X
Bit 0		M Div0		RW			X

**SMBUS Table: SB\_SRC Frequency Control Register**

Byte	17	Name	Control Function	Type	0	1	Default
Bit 7		N Div10	N Divider Programming Byte16 bit(7:0) and Byte15 bit(7:6)	RW	The decimal representation of M and N Divider in Byte 16 and 17 configure the SB_SRC VCO frequency. See M/N Calculation Tables for VCO frequency formulas.		X
Bit 6		N Div9		RW			X
Bit 5		N Div8		RW			X
Bit 4		N Div7		RW			X
Bit 3		N Div6		RW			X
Bit 2		N Div5		RW			X
Bit 1		N Div4		RW			X
Bit 0		N Div3		RW			X

**SMBUS Table: SB\_SRC Spread Spectrum Control Register**

Byte	18	Name	Control Function	Type	0	1	Default
Bit 7		SSP7	Spread Spectrum Programming bit(7:0)	RW	Bytes 18 and 19 set the the SB_SRC spread percentages. Please contact ICS for the appropriate values.		X
Bit 6		SSP6		RW			X
Bit 5		SSP5		RW			X
Bit 4		SSP4		RW			X
Bit 3		SSP3		RW			X
Bit 2		SSP2		RW			X
Bit 1		SSP1		RW			X
Bit 0		SSP0		RW			X

**SMBUS Table: SB\_SRC Spread Spectrum Control Register**

Byte	19	Name	Control Function	Type	0	1	Default
Bit 7		SSP15	Spread Spectrum Programming bit(14:8)	RW	Bytes 18 and 19 set the the SB_SRC spread percentages. Please contact ICS for the appropriate values.		X
Bit 6		SSP14		RW			X
Bit 5		SSP13		RW			X
Bit 4		SSP12		RW			X
Bit 3		SSP11		RW			X
Bit 2		SSP10		RW			X
Bit 1		SSP9		RW			X
Bit 0		SSP8		RW			X

**SMBUS Table: SB\_SRC Output Divider Control Register**

Byte	20	Name	Control Function	Type	0	1	Default
Bit 7		SB_SRC NDiv0	LSB N Divider Programming	RW	SB_SRC M/N programming.		X
Bit 6			Reserved				X
Bit 5			Reserved				X
Bit 4			Reserved				X
Bit 3		SB_SRC Div3	SRC Divider Ratio Programming Bits	RW	0000:/2 ; 0100:/4	1000:/8 ; 1100:/16	X
Bit 2		SB_SRC Div2		RW	0001:/3 ; 0101:/6	1001:/12 ; 1101:/24	X
Bit 1		SB_SRC Div1		RW	0010:/5 ; 0110:/10	1010:/20 ; 1110:/40	X
Bit 0		SB_SRC Div0		RW	0011:/15 ; 0111:/18	1011:/36 ; 1111:/72	X

**SMBus Table: Device ID register**

Byte	21	Name	Control Function	Type	0	1	Default
Bit 7		Device ID7	Device ID	R	76 hex		0
Bit 6		Device ID6		R			1
Bit 5		Device ID5		R			1
Bit 4		Device ID4		R			1
Bit 3		Device ID3		R			0
Bit 2		Device ID2		R			1
Bit 1		Device ID1		R			1
Bit 0		Device ID0		R			0

**SMBus Table: CLKREQ# Configuration Register**

Byte	22	Name	Control Function	Type	0	1	Default
	Bit 7	CPU/HTT/SRC/ATIG M/N En	CPU/HTT/SRC/ATIG PLL M/N Prog. Enable	RW	M/N Prog. Disabled	M/N Prog. Enabled	0
	Bit 6	SB_SRC M/N En	SB_SRC M/N Prog. Enable	RW	M/N Prog. Disabled	M/N Prog. Enabled	0
	Bit 5	Reserved	Reserved	RW	-	-	0
	Bit 4	Reserved	Reserved	RW	-	-	0
	Bit 3	Reserved	Reserved	RW	-	-	0
	Bit 2	Reserved	Reserved	RW	-	-	X
	Bit 1	Reserved	Reserved	RW	-	-	X
	Bit 0	Reserved	Reserved	RW	-	-	X

**SMBus Table: CLKREQ# Configuration Register**

Byte	23	Name	Control Function	Type	0	1	Default
	Bit 7	Reserved	Reserved	RW	-	-	0
	Bit 6	Reserved	Reserved	RW	-	-	0
	Bit 5	CLKREQ4#_Enable	CLKREQ4# controls SRC5	RW	Not Controlled	Controlled	1
	Bit 4	CLKREQ4#_Enable	CLKREQ4# controls SRC4	RW	Not Controlled	Controlled	1
	Bit 3	CLKREQ3#_Enable	CLKREQ3# controls SRC3	RW	Not Controlled	Controlled	1
	Bit 2	CLKREQ2#_Enable	CLKREQ2# controls SRC2	RW	Not Controlled	Controlled	1
	Bit 1	CLKREQ1#_Enable	CLKREQ1# controls SRC1	RW	Not Controlled	Controlled	1
	Bit 0	CLKREQ0#_Enable	CLKREQ0# controls SRC0	RW	Not Controlled	Controlled	1

**SMBus Table: Test Mode Configuration Register**

Byte	24	Name	Control Function	Type	0	1	Default
	Bit 7	Test_Md_Sel	Selects Test Mode	RW	Normal mode	All outputs are REF/N	0
	Bit 6	DIAG Enable#	DIAG enable CPU and LCD PLL	RW	Reset forces B24[6:4,2,0] to 0	DIAG mode Enabled	0
	Bit 5	CPU PLL_LOCK signal	CPU PLL Lock Detect	R	unlocked	Locked	HW
	Bit 4	27MHz PLL_LOCK signal	27MHz PLL Lock Detect	R	unlocked	Locked	HW
	Bit 3	Fixed PLL_LOCK signal	Fixed PLL Lock Detect	R	unlocked	Locked	HW
	Bit 2	SRC PLL_LOCK signal	Fixed PLL Lock Detect	R	unlocked	Locked	HW
	Bit 1	Frequency Check	Primary PLL or external crystal Frequency Accuracy	R	Not Accurate	Accurate	HW
	Bit 0	PWRGD Status	Power on Reset Status	R	Invalid voltage levels on any of the VDDs. CKPWRGD is not asserted or external XTAL not detected.	Valid voltage levels exist on all the VDD. CKPWRGD is asserted and external XTAL is detected.	HW

**SMBus Table:Slew Rate Select Register**

Byte	25	Name	Control Function	Type	0	1	Default
	Bit 7	48MHz_1_Slew Rate	Slew Rate Control	RW	These bits program the slew rate of the single ended outputs. The maximum slew rate is 1.9V/ns and the minimum slew rate is 1.1V/ns. The slew rate selection is as follows: 11 = 1.9V/ns 10 = 1.6V/ns 01 = 1.1V/ns 00 = tristated		1
	Bit 6						1
	Bit 5	REF2_Slew Rate	Slew Rate Control	RW			1
	Bit 4						1
	Bit 3	REF1_Slew Rate	Slew Rate Control	RW			1
	Bit 2						1
	Bit 1	REF0_Slew Rate	Slew Rate Control	RW			1
	Bit 0						1

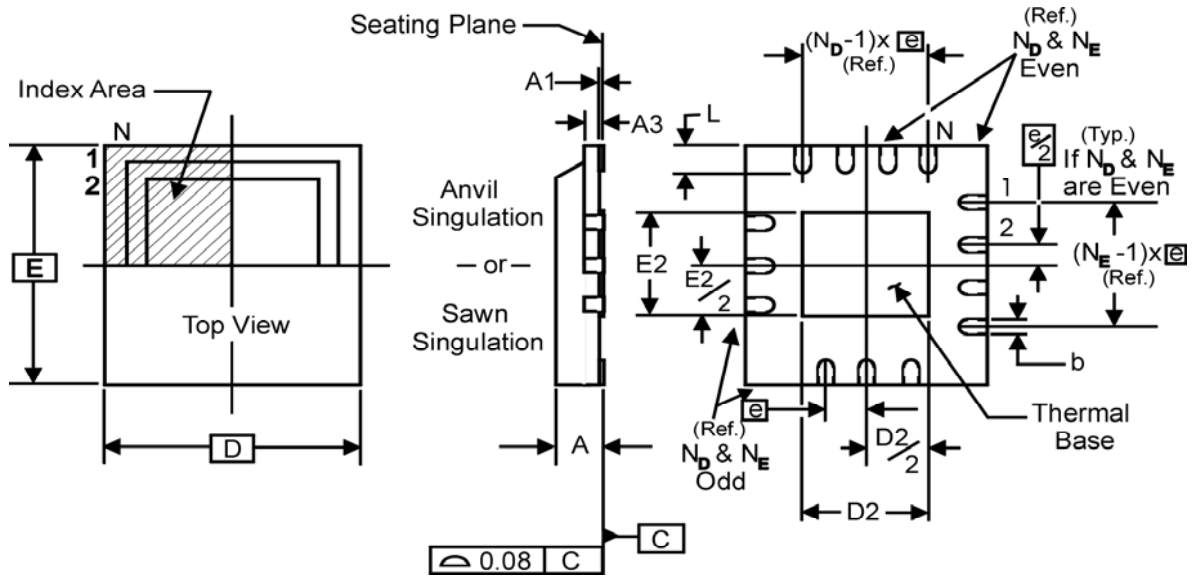

THERMALLY ENHANCED, VERY THIN, FINE PITCH  
QUAD FLAT / NO LEAD PLASTIC PACKAGE

DIMENSIONS

SYMBOL	MIN.	MAX.
A	0.8	1.0
A1	0	0.05
A3	0.25 Reference	
b	0.18	0.3
e	0.50 BASIC	

DIMENSIONS

SYMBOL	ICS 72L TOLERANCE
N	72
N <sub>D</sub>	18
N <sub>E</sub>	18
D x E BASIC	10.00 x 10.00
D2 MIN. / MAX.	5.75 / 6.15
E2 MIN. / MAX.	5.75 / 6.15
L MIN. / MAX.	0.30/ 0.50

Ordering Information

Part/Order Number	Shipping Packaging	Package	Temperature
9EPRS488CKLF	Tubes	72-pin MLF	0 to +70° C
9EPRS488CKLFT	Tape and Reel	72-pin MLF	0 to +70° C

Parts that are ordered with a "LF" suffix to the part number are the Pb-Free configuration and are RoHS compliant. Due to package size constraints, actual top-side marking may differ from the full orderable part number.

**Revision History**

<b>Rev.</b>	<b>Issue Date</b>	<b>Description</b>	<b>Page #</b>
0.1	7/31/2009	Initial Release	-
A	8/20/2009	Release to final	-

## IMPORTANT NOTICE AND DISCLAIMER

RENESAS ELECTRONICS CORPORATION AND ITS SUBSIDIARIES (“RENESAS”) PROVIDES TECHNICAL SPECIFICATIONS AND RELIABILITY DATA (INCLUDING DATASHEETS), DESIGN RESOURCES (INCLUDING REFERENCE DESIGNS), APPLICATION OR OTHER DESIGN ADVICE, WEB TOOLS, SAFETY INFORMATION, AND OTHER RESOURCES “AS IS” AND WITH ALL FAULTS, AND DISCLAIMS ALL WARRANTIES, EXPRESS OR IMPLIED, INCLUDING, WITHOUT LIMITATION, ANY IMPLIED WARRANTIES OF MERCHANTABILITY, FITNESS FOR A PARTICULAR PURPOSE, OR NON-INFRINGEMENT OF THIRD-PARTY INTELLECTUAL PROPERTY RIGHTS.

These resources are intended for developers who are designing with Renesas products. You are solely responsible for (1) selecting the appropriate products for your application, (2) designing, validating, and testing your application, and (3) ensuring your application meets applicable standards, and any other safety, security, or other requirements. These resources are subject to change without notice. Renesas grants you permission to use these resources only to develop an application that uses Renesas products. Other reproduction or use of these resources is strictly prohibited. No license is granted to any other Renesas intellectual property or to any third-party intellectual property. Renesas disclaims responsibility for, and you will fully indemnify Renesas and its representatives against, any claims, damages, costs, losses, or liabilities arising from your use of these resources. Renesas' products are provided only subject to Renesas' Terms and Conditions of Sale or other applicable terms agreed to in writing. No use of any Renesas resources expands or otherwise alters any applicable warranties or warranty disclaimers for these products.

(Disclaimer Rev.1.01 Jan 2024)

### Corporate Headquarters

TOYOSU FORESIA, 3-2-24 Toyosu,  
Koto-ku, Tokyo 135-0061, Japan  
[www.renesas.com](http://www.renesas.com)

### Trademarks

Renesas and the Renesas logo are trademarks of Renesas Electronics Corporation. All trademarks and registered trademarks are the property of their respective owners.

### Contact Information

For further information on a product, technology, the most up-to-date version of a document, or your nearest sales office, please visit [www.renesas.com/contact-us/](http://www.renesas.com/contact-us/).

## Looking for pricing, stock, or lifecycle information?

Click below to explore more details on WIN SOURCE:

-  [View 9EPRS488CKLFT on WIN SOURCE](#)
-  [Renesas Electronics America](#) Information

## Optimize Your Supply Chain with WIN SOURCE Solutions

-  Global Sourcing Solution
-  Obsolete Management
-  Cost Control Management
-  Shortage Management
-  Alternative Solution
-  Excess Inventory Management