



**THE DATASHEET OF**  
**8S89832AKILFT**



## Description

The 8S89832I is a high speed 1-to-4 Differential-to-LVDS Fanout Buffer. The 8S89832I is optimized for high speed and very low output skew, making it suitable for use in demanding applications such as SONET, 1 Gigabit and 10 Gigabit Ethernet, and Fibre Channel. The internally terminated differential input and VREF\_AC pin allow other differential signal families such as LVPECL, LVDS, and SSTL to be easily interfaced to the input with minimal use of external components. The device also has an output enable pin that may be useful for system test and debug purposes.

The 8S89832I is packaged in a small 3mm x 3mm 16-pin VFQFN package which makes it ideal for use in space-constrained applications.

## Features

- Four differential LVDS output pairs
- IN, nIN input pairs can accept the following differential input levels: LVPECL, LVDS, SSTL
- 50Ω internal input termination to V<sub>T</sub>
- Maximum output frequency: 2GHz
- Output skew: 25ps (maximum)
- Part-to-part skew: 200ps (maximum)
- Propagation delay: 550ps (maximum)
- Additive phase jitter, RMS: 0.09ps (typical)
- Full 2.5V supply mode
- -40°C to 85°C ambient operating temperature
- Available in lead-free (RoHS 6) package

## Block Diagram

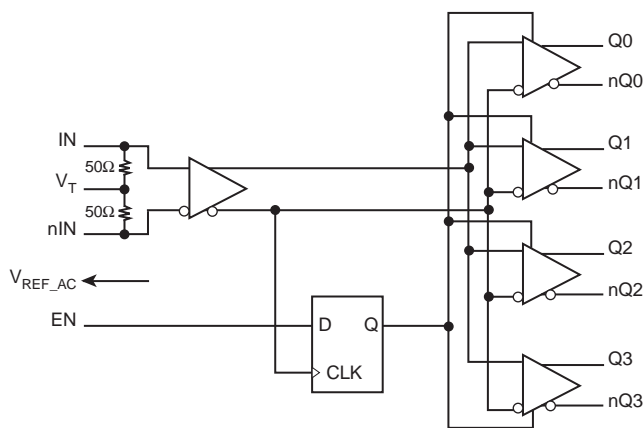

## Pin Assignment

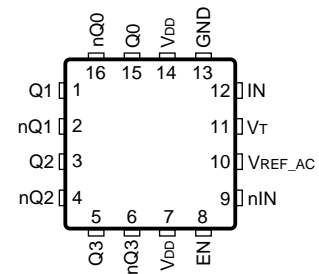

**8S89832I**

**16-Lead VFQFN**

**3mm x 3mm x 0.925mm package body**

**K Package**

**Top View**

**Table 1. Pin Descriptions**

Number	Name	Type		Description
1, 2	Q1, nQ1	Output		Differential output pair. LVDS interface levels.
3, 4	Q2, nQ2	Output		Differential output pair. LVDS interface levels.
5, 6	Q3, nQ3	Output		Differential output pair. LVDS interface levels.
7, 14	V <sub>DD</sub>	Power		Positive supply pins.
8	EN	Input	Pullup	Synchronizing clock enable. When LOW, Qx outputs will go LOW and nQx outputs will go HIGH on the next LOW transition at IN inputs. Input threshold is V <sub>DD</sub> /2V. Includes a 37kΩ pullup resistor. Default state is HIGH when left floating. The internal latch is clocked on the falling edge of the input signal IN. See Table 3A LVTTTL / LVCMOS interface levels.
9	nIN	Input		Inverting differential clock input. 50Ω internal input termination to V <sub>T</sub> .
10	V <sub>REF_AC</sub>	Output		Reference voltage for AC-coupled applications.
11	V <sub>T</sub>	Input		Termination input.
12	IN	Input		Non-inverting differential clock input. 50Ω internal input termination to V <sub>T</sub> .
13	GND	Power		Power supply ground.
15, 16	Q0, nQ0	Output		Differential output pair. LVDS interface levels.

NOTE: *Pullup* refers to internal input resistors. See Table 2, *Pin Characteristics*, for typical values.

**Table 2. Pin Characteristics**

Symbol	Parameter	Test Conditions	Minimum	Typical	Maximum	Units
C <sub>IN</sub>	Input Capacitance			2		pF
R <sub>PULLUP</sub>	Input Pullup Resistor			37		kΩ

## Function Tables

Table 3A. Control Input Function Table

Input	Outputs	
	Q[0:3]	nQ[0:3]
0	Disabled; LOW	Disabled; HIGH
1	Enabled	Enabled

NOTE: EN switches, the clock outputs are disabled or enabled following a falling input clock edge as shown in Figure 1.

Figure 1. EN Timing Diagram

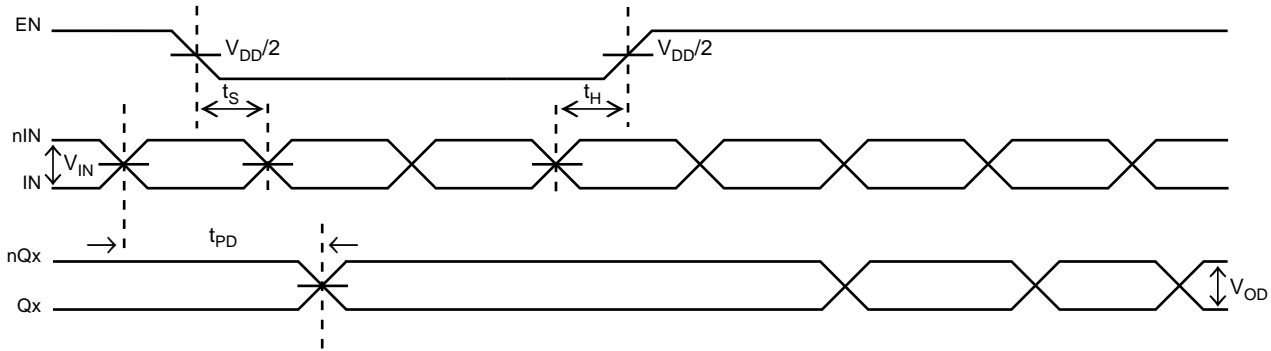

Table 3B. Truth Table

Inputs			Outputs	
IN	nIN	EN	Q[0:3]	nQ[0:3]
0	1	1	0	1
1	0	1	1	0
X	X	0	0 (NOTE 1)	1 (NOTE 1)

NOTE 1: On next negative transition of the input signal (IN).

## Absolute Maximum Ratings

Stresses beyond those listed under *Absolute Maximum Ratings* may cause permanent damage to the device. These ratings are stress specifications only. Functional operation of product at these conditions or any conditions beyond those listed in the *DC Characteristics* or *AC Characteristics* is not implied. Exposure to absolute maximum rating conditions for extended periods may affect product reliability.

Item	Rating
Supply Voltage, $V_{DD}$	4.6V
Inputs, $V_I$	-0.5V to $V_{DD} + 0.5V$
Outputs, $I_O$ Continuous Current Surge Current	10mA 15mA
Input Current, $I_{IN}$ , nI <sub>N</sub>	±50mA
$V_T$ Current, $I_{VT}$	±100mA
Input Sink/Source, $I_{REF\_AC}$	± 0.5mA
Operating Temperature Range, $T_A$	-40°C to +85°C
Package Thermal Impedance, $\theta_{JA}$ , (Junction-to-Ambient)	74.7°C/W (0 mps)
Storage Temperature, $T_{STG}$	-65°C to 150°C

## DC Electrical Characteristics

**Table 4A. Power Supply DC Characteristics,  $V_{DD} = 2.5V \pm 5\%$ ,  $T_A = -40^\circ C$  to  $85^\circ C$**

Symbol	Parameter	Test Conditions	Minimum	Typical	Maximum	Units
$V_{DD}$	Positive Supply Voltage		2.375	2.5	2.625	V
$I_{DD}$	Power Supply Current				95	mA

**Table 4B. LVC MOS/LVTTL DC Characteristics,  $V_{DD} = 2.5V \pm 5\%$ ,  $T_A = -40^\circ C$  to  $85^\circ C$**

Symbol	Parameter	Test Conditions	Minimum	Typical	Maximum	Units
$V_{IH}$	Input High Voltage		1.7		$V_{DD} + 0.3$	V
$V_{IL}$	Input Low Voltage		-0.3		0.7	V
$I_{IH}$	Input High Current	$V_{DD} = V_{IN} = 2.625V$			10	μA
$I_{IL}$	Input Low Current	$V_{DD} = 2.625V, V_{IN} = 0V$	-150			μA

**Table 4C. Differential DC Characteristics,  $V_{DD} = 2.5V \pm 5\%$ ,  $T_A = -40^\circ C$  to  $85^\circ C$** 

Symbol	Parameter	Test Conditions	Minimum	Typical	Maximum	Units
$R_{IN}$	Differential Input Resistance	IN, nIN	40	50	60	$\Omega$
$V_{IH}$	Input High Voltage	IN, nIN	1.2		$V_{DD}$	V
$V_{IL}$	Input Low Voltage	IN, nIN	0		$V_{IH} - 0.15$	V
$V_{IN}$	Input Voltage Swing; NOTE 1		0.15		1.2	V
$V_{DIFF\_IN}$	Differential Input Voltage Swing		0.3			V
$I_{IN}$	Input Current; NOTE 2	IN, nIN			35	mA
$V_{REF\_AC}$	Reference Voltage		$V_{DD} - 1.40$	$V_{DD} - 1.35$	$V_{DD} - 1.30$	V

NOTE 1:  $V_{IL}$  should not be less than -0.3V.

NOTE 2: Guaranteed by design.

**Table 4D. LVDS DC Characteristics,  $V_{DD} = 2.5V \pm 5\%$ ,  $T_A = -40^\circ C$  to  $85^\circ C$** 

Symbol	Parameter	Test Conditions	Minimum	Typical	Maximum	Units
$V_{OD}$	Differential Output Voltage		247		454	mV
$\Delta V_{OD}$	$V_{OD}$ Magnitude Change				50	mV
$V_{OS}$	Offset Voltage		1.125		1.375	V
$\Delta V_{OS}$	$V_{OS}$ Magnitude Change				50	mV

## AC Electrical Characteristics

**Table 5. AC Characteristics,  $V_{DD} = 2.5V \pm 5\%$ ,  $T_A = -40^\circ C$  to  $85^\circ C$** 

Symbol	Parameter	Test Conditions	Minimum	Typical	Maximum	Units
$f_{OUT}$	Operating Frequency				2	GHz
$t_{PD}$	Propagation Delay; (Differential) NOTE 1		300		550	ps
$t_{sk(o)}$	Output Skew; NOTE 2, 3				25	ps
$t_{sk(pp)}$	Part-to-Part Skew; NOTE 3, 4				200	ps
$f_{jit}$	Buffer Additive Phase Jitter, RMS; refer to Additive Phase Jitter Section	200MHz, Integration Range: 12kHz - 20MHz		0.09		ps
$t_s / t_H$	Clock Enable Setup Time	EN to IN, nIN	300			ps
$t_R / t_F$	Output Rise/Fall Time	20% to 80%	50		235	ps

NOTE: Electrical parameters are guaranteed over the specified ambient operating temperature range, which is established when the device is mounted in a test socket with maintained transverse airflow greater than 500 lfm. The device will meet specifications after thermal equilibrium has been reached under these conditions.

All parameters are measured at  $\leq 1.5$ GHz unless otherwise noted.

NOTE 1: Measured from the differential input crossing point to the differential output crossing point.

NOTE 2: Defined as skew between outputs at the same supply voltage and with equal load conditions.

Measured at the output differential cross points.

NOTE 3: This parameter is defined in accordance with JEDEC Standard 65.

NOTE 4: Defined as skew between outputs on different devices operating at the same supply voltage, same temperature, same frequency and with equal load conditions. Using the same type of inputs on each device, the outputs are measured at the differential cross points.

## Additive Phase Jitter

The spectral purity in a band at a specific offset from the fundamental compared to the power of the fundamental is called the ***dBc Phase Noise***. This value is normally expressed using a Phase noise plot and is most often the specified plot in many applications. Phase noise is defined as the ratio of the noise power present in a 1Hz band at a specified offset from the fundamental frequency to the power value of the fundamental. This ratio is expressed in decibels (dBm) or a ratio of the power in the 1Hz band to the power in the

fundamental. When the required offset is specified, the phase noise is called a ***dBc*** value, which simply means dBm at a specified offset from the fundamental. By investigating jitter in the frequency domain, we get a better understanding of its effects on the desired application over the entire time record of the signal. It is mathematically possible to calculate an expected bit error rate given a phase noise plot.

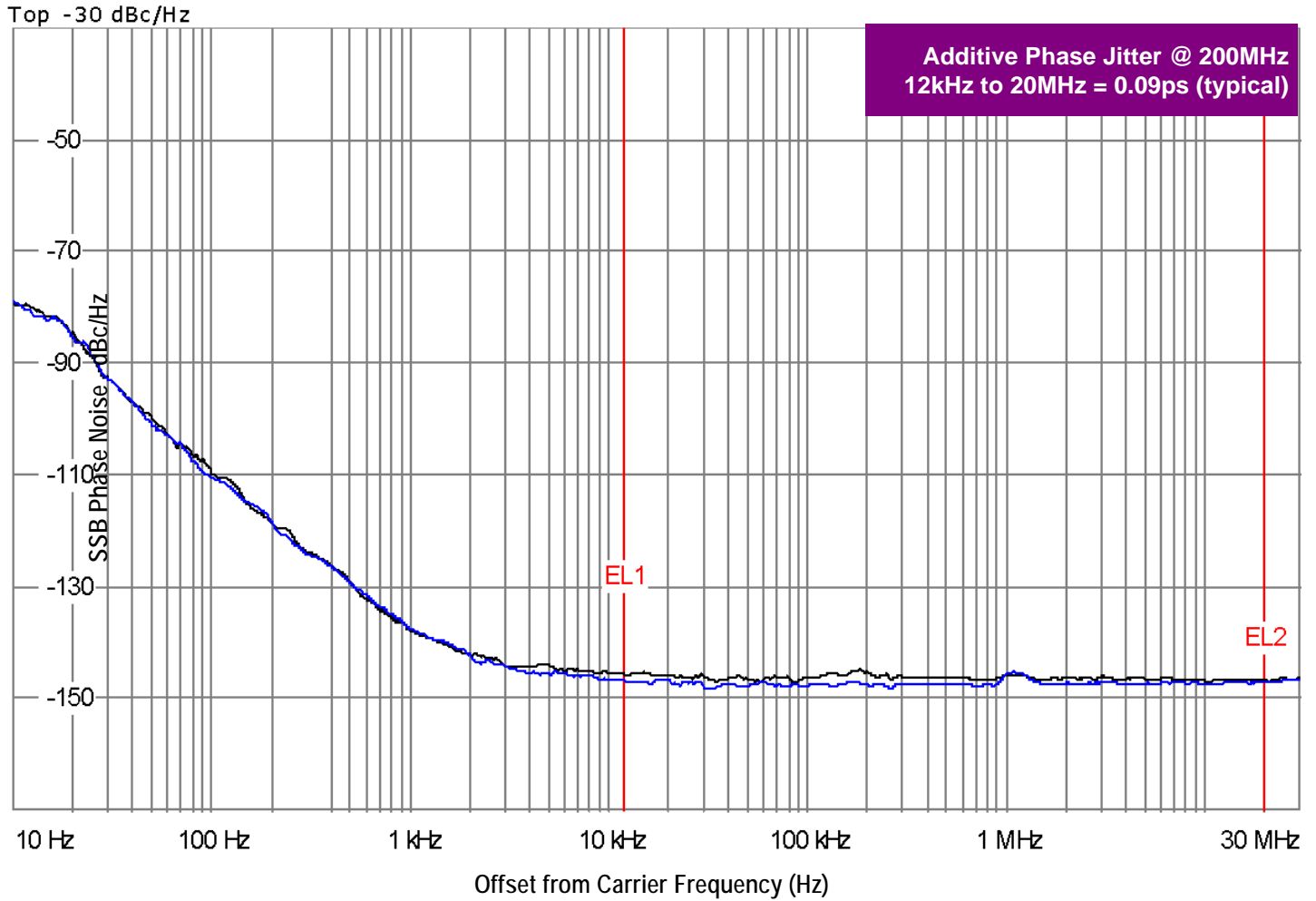

As with most timing specifications, phase noise measurements has issues relating to the limitations of the equipment. Often the noise floor of the equipment is higher than the noise floor of the device. This is illustrated above. The device meets the noise floor of what is shown, but can actually be lower. The phase noise is dependent on the input source and measurement equipment.

The source generator "IFR2042 10kHz – 56.4GHz Low Noise Signal Generator as external input to an Agilent 8133A 3GHz Pulse Generator".

## Parameter Measurement Information

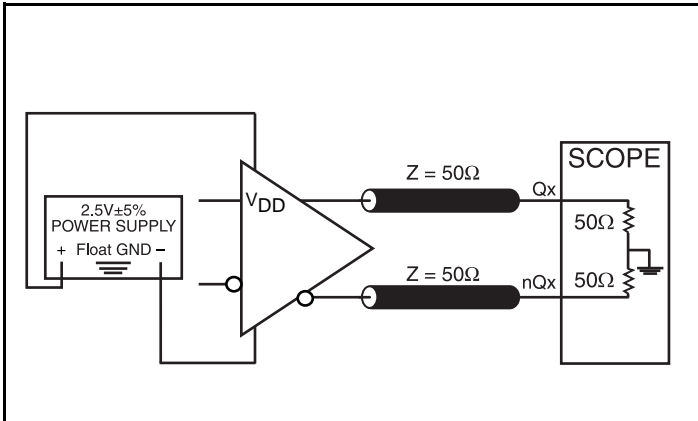

LVDS Output Load AC Test Circuit

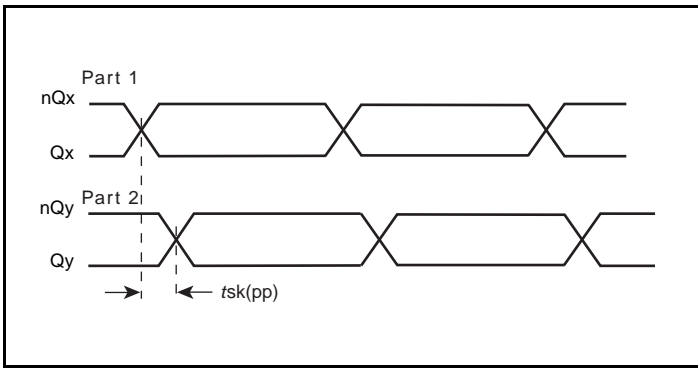
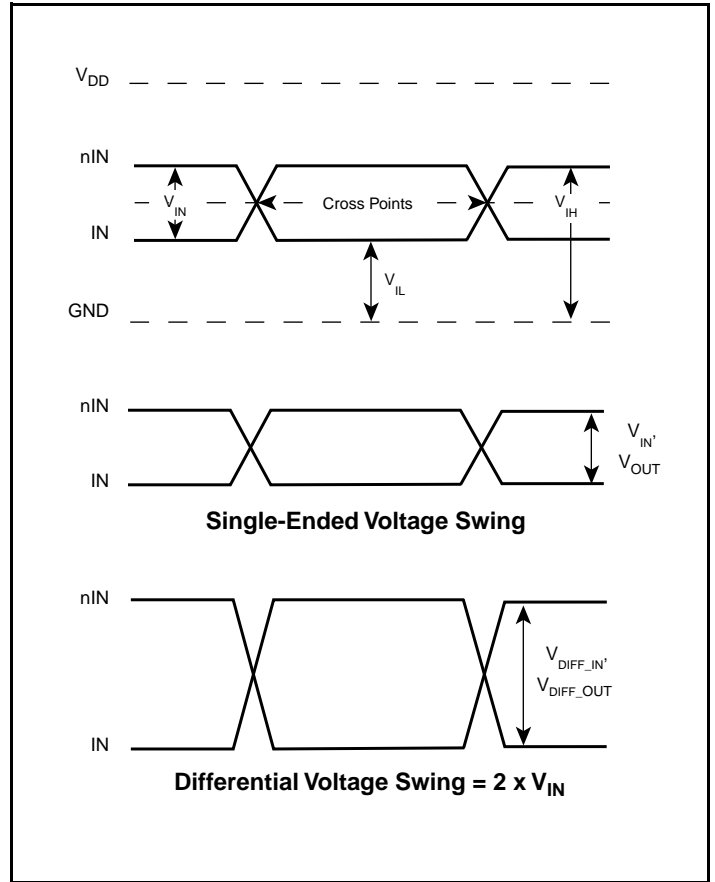

Part-to-Part Skew

Differential Input Level

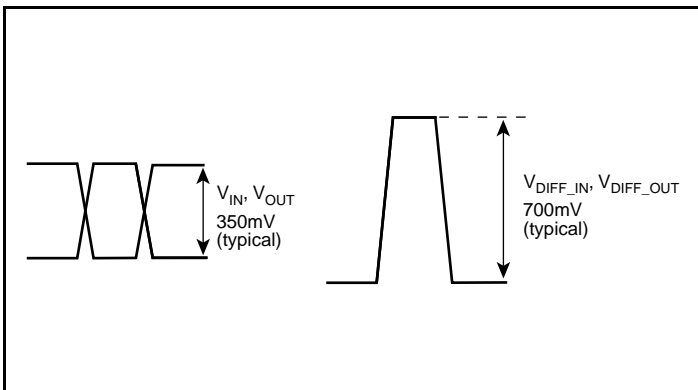

Single-Ended & Differential Input, Output Voltage Swing

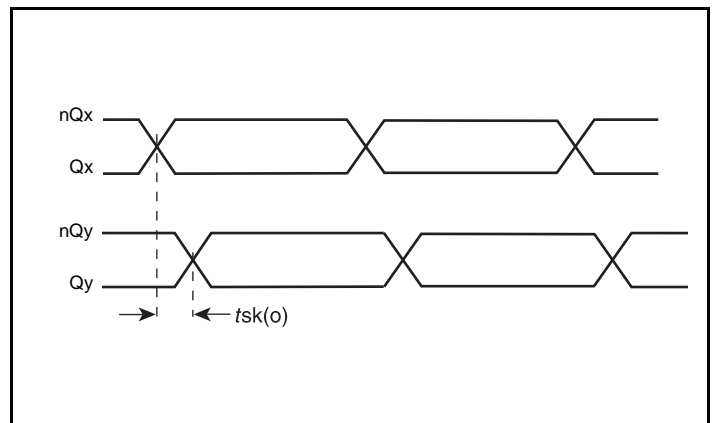

Output Skew

Parameter Measurement Information, continued

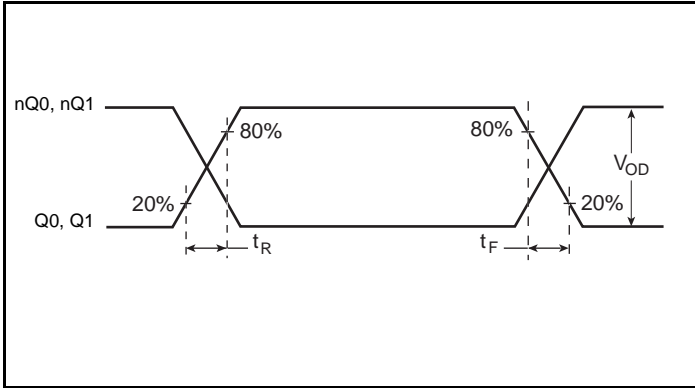

Output Rise/Fall Time

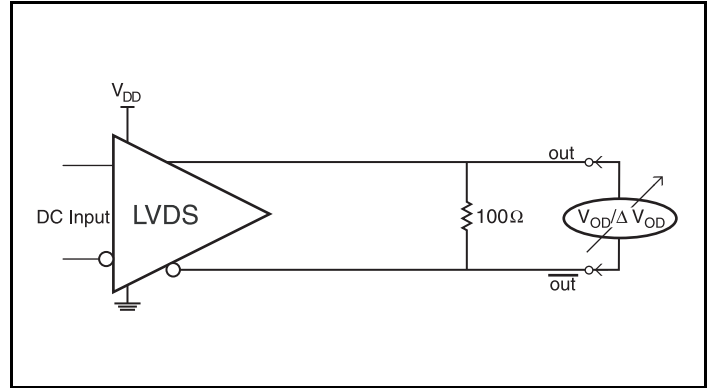

Differential Output Voltage Setup

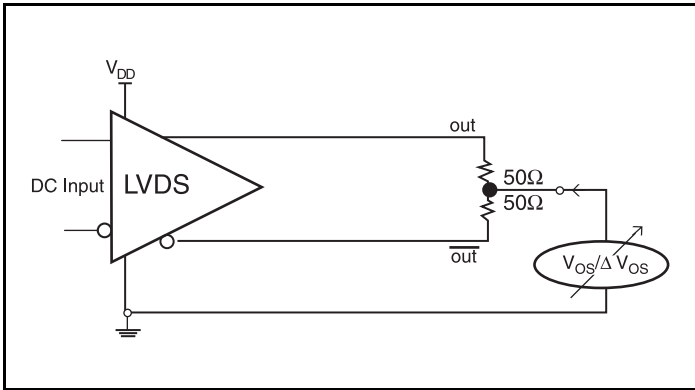

Offset Voltage Setup

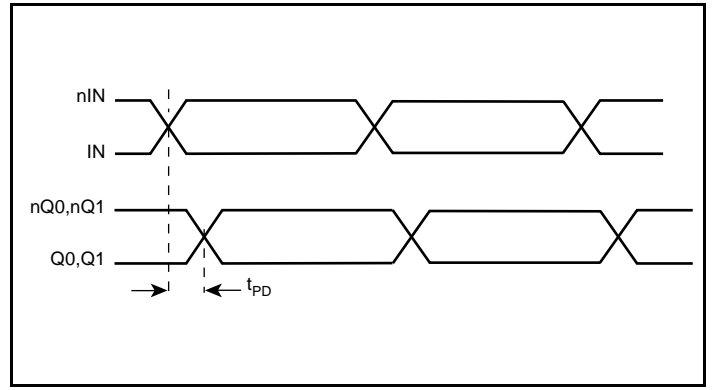

Propagation Delay

## Application Information

### Recommendations for Unused Output Pins

#### Outputs

##### LVDS Outputs

All unused LVDS output pairs can be either left floating or terminated with  $100\Omega$  across. If they are left floating, we recommend that there is no trace attached.

### 2.5V LVPECL Input with Built-In $50\Omega$ Termination Interface

The IN/nIN with built-in  $50\Omega$  terminations accept LVDS, LVPECL, SSTL and other differential signals. Both differential signals must meet the  $V_{PP}$  and  $V_{CMR}$  input requirements. Figures 2A to 2D show interface examples for the IN/nIN with built-in  $50\Omega$  termination input driven by the most common driver types. The input interfaces

suggested here are examples only. If the driver is from another vendor, use their termination recommendation. Please consult with the vendor of the driver component to confirm the driver termination requirements.

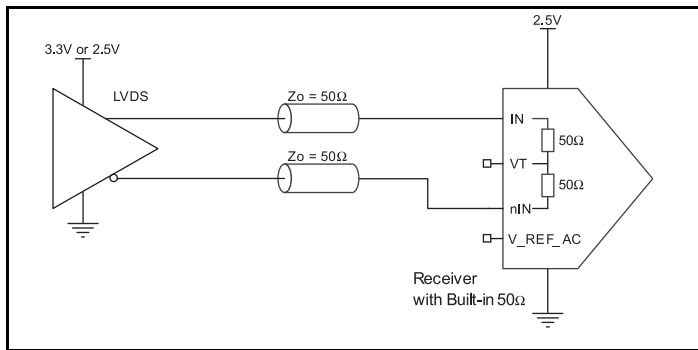

Figure 2A. IN/nIN Input with Built-In  $50\Omega$  Driven by an LVDS Driver

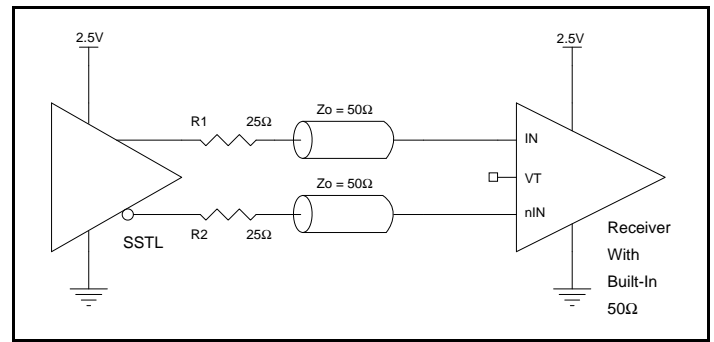

Figure 2B. IN/nIN Input with Built-In  $50\Omega$  Driven by an SSTL Driver

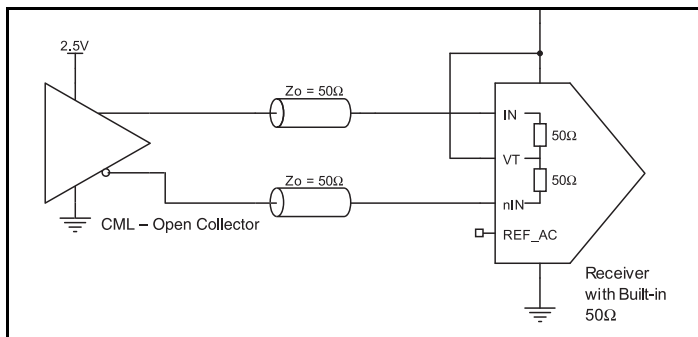

Figure 2C. IN/nIN Input with Built-In  $50\Omega$  Driven by a CML Driver

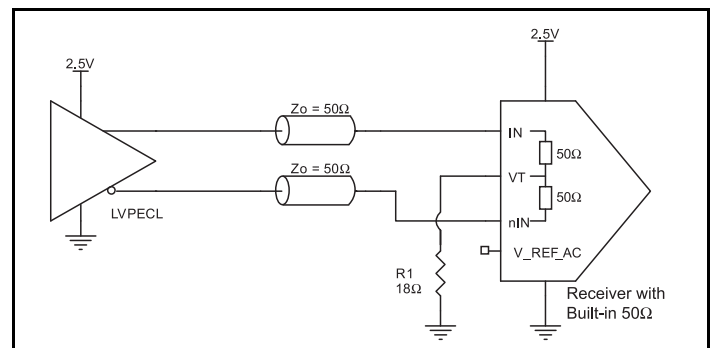

Figure 2D. IN/nIN Input with Built-In  $50\Omega$  Driven by an LVPECL Driver

### VFQFN EPAD Thermal Release Path

In order to maximize both the removal of heat from the package and the electrical performance, a land pattern must be incorporated on the Printed Circuit Board (PCB) within the footprint of the package corresponding to the exposed metal pad or exposed heat slug on the package, as shown in *Figure 3*. The solderable area on the PCB, as defined by the solder mask, should be at least the same size/shape as the exposed pad/slug area on the package to maximize the thermal/electrical performance. Sufficient clearance should be designed on the PCB between the outer edges of the land pattern and the inner edges of pad pattern for the leads to avoid any shorts.

While the land pattern on the PCB provides a means of heat transfer and electrical grounding from the package to the board through a solder joint, thermal vias are necessary to effectively conduct from the surface of the PCB to the ground plane(s). The land pattern must be connected to ground through these vias. The vias act as "heat pipes". The number of vias (i.e. "heat pipes") are application specific

and dependent upon the package power dissipation as well as electrical conductivity requirements. Thus, thermal and electrical analysis and/or testing are recommended to determine the minimum number needed. Maximum thermal and electrical performance is achieved when an array of vias is incorporated in the land pattern. It is recommended to use as many vias connected to ground as possible. It is also recommended that the via diameter should be 12 to 13mils (0.30 to 0.33mm) with 1oz copper via barrel plating. This is desirable to avoid any solder wicking inside the via during the soldering process which may result in voids in solder between the exposed pad/slug and the thermal land. Precautions should be taken to eliminate any solder voids between the exposed heat slug and the land pattern. Note: These recommendations are to be used as a guideline only. For further information, please refer to the Application Note on the Surface Mount Assembly of Amkor's Thermally/Electrically Enhance Leadframe Base Package, Amkor Technology.

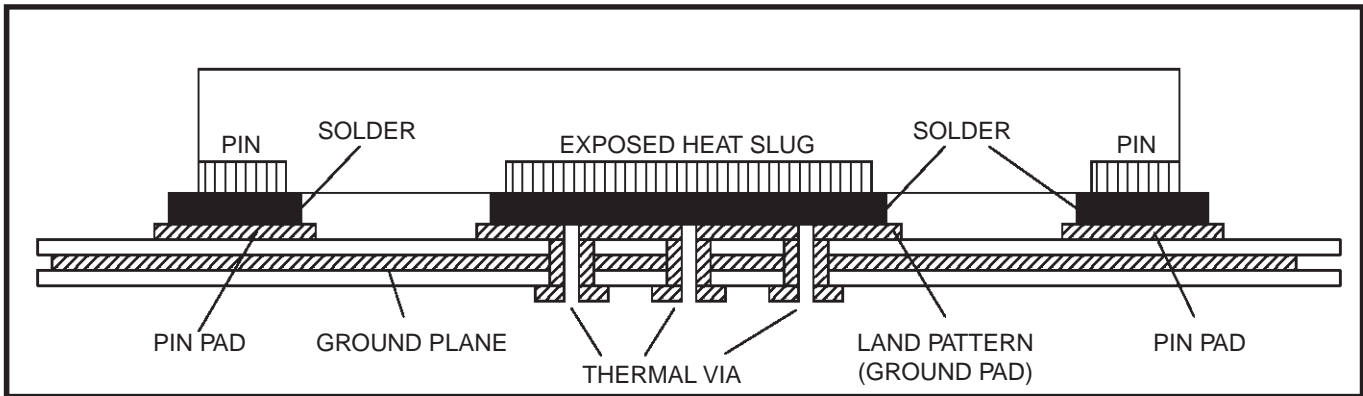
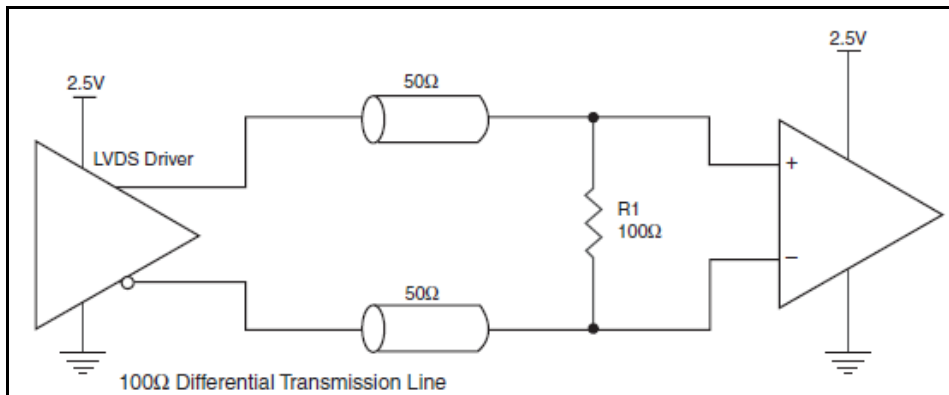

**Figure 3. P.C. Assembly for Exposed Pad Thermal Release Path – Side View (drawing not to scale)**

### 2.5V LVDS Driver Termination

*Figure 4* shows a typical termination for LVDS driver in characteristic impedance of 100Ω differential (50Ω single)

transmission line environment. For buffer with multiple LVDS driver, it is recommended to terminate the unused outputs.



**Figure 4. Typical LVDS Driver Termination**

## Power Considerations

This section provides information on power dissipation and junction temperature for the 8S89832I. Equations and example calculations are also provided.

### 1. Power Dissipation.

The total power dissipation for the 8S89832I is the sum of the core power plus the analog power plus the power dissipated in the load(s). The following is the power dissipation for  $V_{DD} = 2.5V + 5\% = 2.625V$ , which gives worst case results.

NOTE: Please refer to Section 3 for details on calculating power dissipated in the load.

- Power (core)<sub>MAX</sub> =  $V_{DD\_MAX} * I_{DD\_MAX} = 2.625V * 95mA = 249.375mW$

### 2. Junction Temperature.

Junction temperature,  $T_j$ , is the temperature at the junction of the bond wire and bond pad directly affects the reliability of the device. The maximum recommended junction temperature is 125°C. Limiting the internal transistor junction temperature,  $T_j$ , to 125°C ensures that the bond wire and bond pad temperature remains below 125°C.

The equation for  $T_j$  is as follows:  $T_j = \theta_{JA} * Pd\_total + T_A$

$T_j$  = Junction Temperature

$\theta_{JA}$  = Junction-to-Ambient Thermal Resistance

$Pd\_total$  = Total Device Power Dissipation (example calculation is in section 1 above)

$T_A$  = Ambient Temperature

In order to calculate junction temperature, the appropriate junction-to-ambient thermal resistance  $\theta_{JA}$  must be used. Assuming no air flow and a multi-layer board, the appropriate value is 74.7°C/W per Table 6 below.

Therefore,  $T_j$  for an ambient temperature of 85°C with all outputs switching is:

$$85^\circ\text{C} + 0.249\text{W} * 74.7^\circ\text{C}/\text{W} = 103.6^\circ\text{C}. \text{ This is well below the limit of } 125^\circ\text{C}.$$

This calculation is only an example.  $T_j$  will obviously vary depending on the number of loaded outputs, supply voltage, air flow and the type of board (multi-layer).

**Table 6. Thermal Resistance  $\theta_{JA}$  for 16 Lead VFQFN Forced Convection**

Meters per Second	$\theta_{JA}$ by Velocity		
	0	1	2.5
Multi-Layer PCB, JEDEC Standard Test Boards	74.7°C/W	65.3°C/W	58.5°C/W

## Reliability Information

**Table 7.  $\theta_{JA}$  vs. Air Flow Table for a 16 Lead VFQFN**

Meters per Second	$\theta_{JA}$ by Velocity		
	0	1	2.5
Multi-Layer PCB, JEDEC Standard Test Boards	74.7°C/W	65.3°C/W	58.5°C/W

## Transistor Count

The transistor count for 8S89832I is: 339

Pin compatible with SY89832U.

This device is pin and function compatible and a suggested replacement for 889832.

## Package Outline Drawings

The package outline drawings are located in the last section of this document. The package information is the most current data available and is subject to change without notice or revision of this document.

## Ordering Information

**Table 9. Ordering Information**

Part/Order Number	Marking	Package	Shipping Packaging	Temperature
8S89832AKILF	832A	"Lead-Free" 16 Lead VFQFN	Tube	-40°C to 85°C
8S89832AKILFT	832A	"Lead-Free" 16 Lead VFQFN	Tape & Reel	-40°C to 85°C

## Revision History

Revision Date	Description of Change
September 22, 2017	Updated the package outline drawings; however, no mechanical changes Completed other minor improvements
January 27, 2016	Removed ICS from part numbers where needed. General Description - Deleted ICS chip. Ordering Information - Deleted quantity from tape and reel. Deleted LF note below table. Updated header and footer.
January 11, 2010	Parameter Measurement Information - updated <i>Differential Input Level</i> diagram.

# 16L-QFN Package Outline Drawing

3.0 x 3.0 x 1.0 mm, 0.5 mm Pitch, 1.70 x 1.70 mm Epad  
 NL/NLG16P2, PSC-4169-02, Rev 03, Page 1

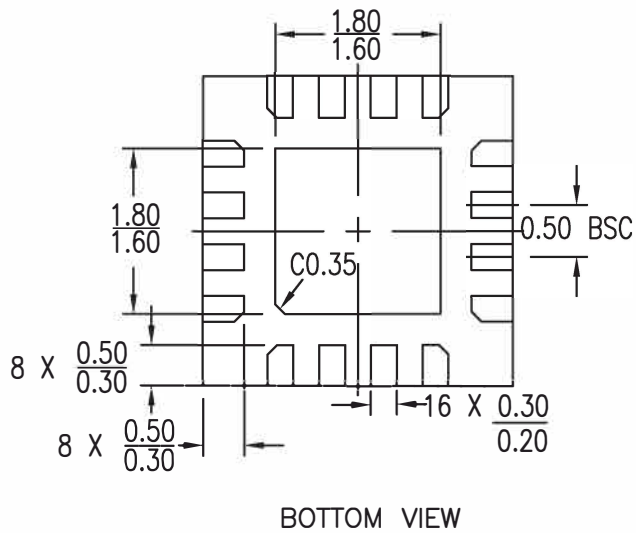
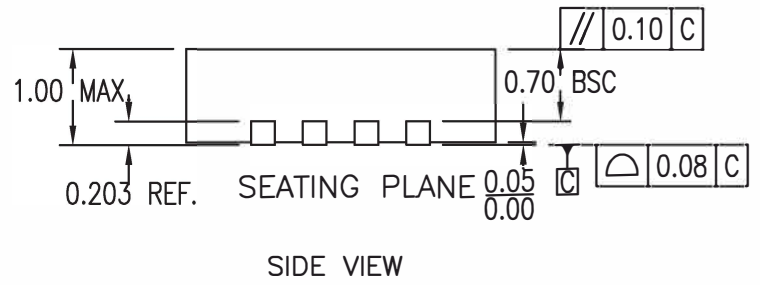
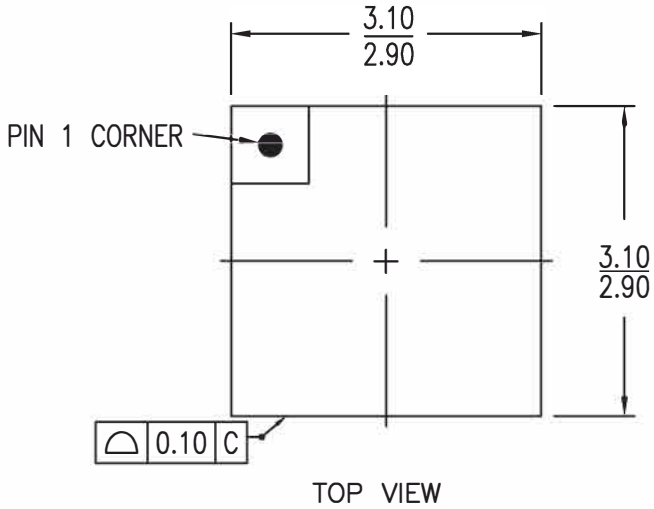

NOTES:  
 1. ALL DIMENSIONS ARE IN mm.ANGLES IN DEGREES

# 16L-QFN Package Outline Drawing

3.0 x 3.0 x 1.0 mm, 0.5 mm Pitch, 1.70 x 1.70 mm Epad

NL/NLG16P2, PSC-4169-02, Rev 03, Page 2

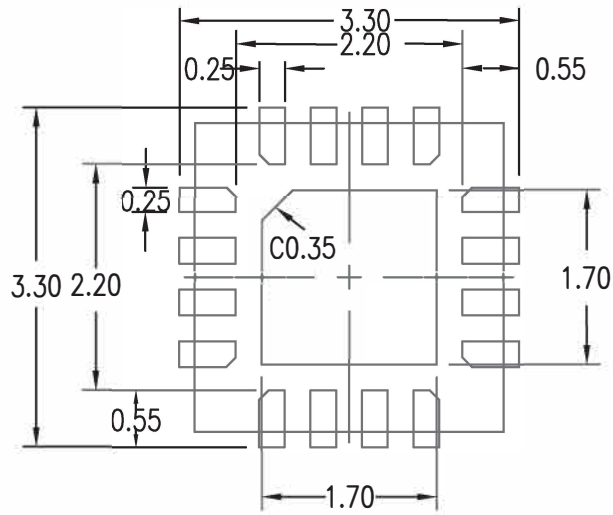

## IMPORTANT NOTICE AND DISCLAIMER

RENESAS ELECTRONICS CORPORATION AND ITS SUBSIDIARIES (“RENESAS”) PROVIDES TECHNICAL SPECIFICATIONS AND RELIABILITY DATA (INCLUDING DATASHEETS), DESIGN RESOURCES (INCLUDING REFERENCE DESIGNS), APPLICATION OR OTHER DESIGN ADVICE, WEB TOOLS, SAFETY INFORMATION, AND OTHER RESOURCES “AS IS” AND WITH ALL FAULTS, AND DISCLAIMS ALL WARRANTIES, EXPRESS OR IMPLIED, INCLUDING, WITHOUT LIMITATION, ANY IMPLIED WARRANTIES OF MERCHANTABILITY, FITNESS FOR A PARTICULAR PURPOSE, OR NON-INFRINGEMENT OF THIRD-PARTY INTELLECTUAL PROPERTY RIGHTS.

These resources are intended for developers who are designing with Renesas products. You are solely responsible for (1) selecting the appropriate products for your application, (2) designing, validating, and testing your application, and (3) ensuring your application meets applicable standards, and any other safety, security, or other requirements. These resources are subject to change without notice. Renesas grants you permission to use these resources only to develop an application that uses Renesas products. Other reproduction or use of these resources is strictly prohibited. No license is granted to any other Renesas intellectual property or to any third-party intellectual property. Renesas disclaims responsibility for, and you will fully indemnify Renesas and its representatives against, any claims, damages, costs, losses, or liabilities arising from your use of these resources. Renesas' products are provided only subject to Renesas' Terms and Conditions of Sale or other applicable terms agreed to in writing. No use of any Renesas resources expands or otherwise alters any applicable warranties or warranty disclaimers for these products.

(Disclaimer Rev.1.01 Jan 2024)

### Corporate Headquarters

TOYOSU FORESIA, 3-2-24 Toyosu,  
Koto-ku, Tokyo 135-0061, Japan  
[www.renesas.com](http://www.renesas.com)

### Trademarks

Renesas and the Renesas logo are trademarks of Renesas Electronics Corporation. All trademarks and registered trademarks are the property of their respective owners.

### Contact Information

For further information on a product, technology, the most up-to-date version of a document, or your nearest sales office, please visit [www.renesas.com/contact-us/](http://www.renesas.com/contact-us/).

## Looking for pricing, stock, or lifecycle information?

Click below to explore more details on WIN SOURCE:

-  [View 8S89832AKILFT on WIN SOURCE](#)
-  [Renesas Electronics America](#) Information

## Optimize Your Supply Chain with WIN SOURCE Solutions

-  Global Sourcing Solution
-  Obsolete Management
-  Cost Control Management
-  Shortage Management
-  Alternative Solution
-  Excess Inventory Management