



**THE DATASHEET OF
854S712AKILF**



Description

The 854S712 is a differential, high-speed 1:2 data/clock fanout buffer and line driver. The outputs support pre-emphasis in order to drive backplanes and long transmission lines while reducing inter-symbol interference effects. The pre-emphasis level is configurable to optimize for low bit error rate or power consumption. Pre-emphasis utilizes an increased output voltage swing for transition bits.

The device is optimized for data rates up to 4.5 Gbps (NRZ) and for deterministic jitter in data applications and low additive jitter in clock applications. The outputs are LVDS-compliant while the differential input is compatible with a variety of signal levels such as LVDS, LVPECL and CML. Internal input termination, a bias voltage output for AC-coupling and small packaging (VFQFN) supports space-efficient board designs. The 854S712 operates from a 3.3V power supply and supports the industrial temperature range of -40°C to +85°C.

Pin Assignment

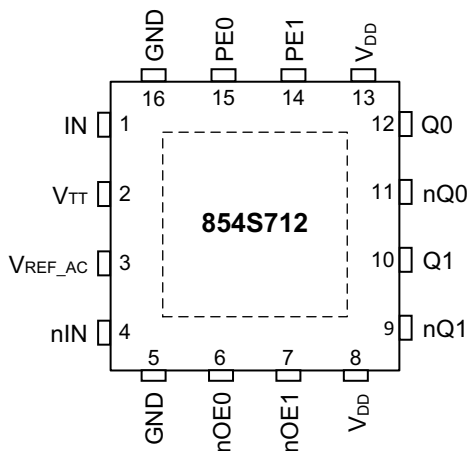

16-pin, 3mm x 3mm VFQFN Package

Features

- 1:2 differential data/clock fanout buffer and line driver
- 4.5 Gbps data rate (NRZ) (maximum)
- Differential LVDS outputs
- Differential input supporting LVDS, LVPECL and CML levels
- Configurable output pre-emphasis
- Low-skew outputs: 10ps (maximum)
- Low data deterministic jitter: 4ps (maximum)
- LVCMOS interface levels for the control inputs
- Asynchronous output disable into high-impedance state
- Internal input termination: 100Ω (Differential)
- Additive phase jitter, RMS: 0.08ps (typical)
- Full 3.3V supply voltage
- -40°C to 85°C ambient operating temperature
- Available in lead-free (RoHS 6) package

Block Diagram

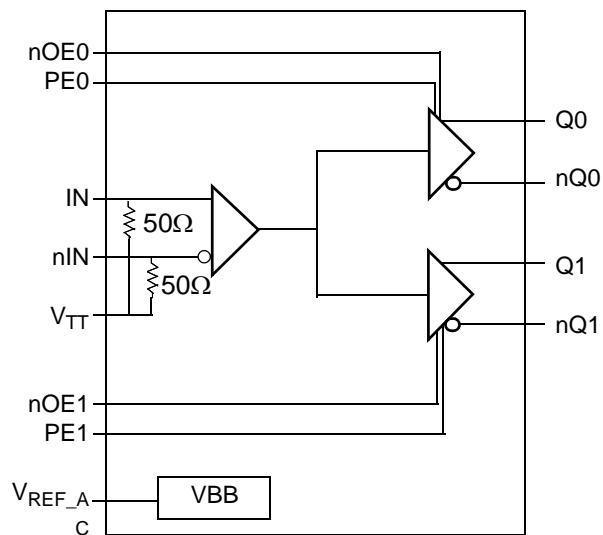

Pin Description and Pin Characteristic Tables

Table 1 Pin Description

Number	Name	Type		Description
1	IN	Input		Non-inverting differential data and clock input. LVDS, LVPECL or CML interface levels. 50Ω to V_{TT} .
4	nIN	Input		Inverting differential data and clock input. LVDS, LVPECL or CML interface levels. 50Ω to V_{TT} .
6, 7	nOE0, nOE1	Input	Pulldown	Output enable control. LVCMOS/LVTTL interface levels.
15, 14	PE0, PE1	Input	Pulldown	Pre-emphasis control. LVCMOS/LVTTL interface levels.
12, 11	Q0, nQ0	Output		Differential output pair. LVDS interface levels.
10, 9	Q1, nQ1	Output		Differential output pair. LVDS interface levels.
3	V_{REF_AC}	Output		Bias voltage reference for AC-coupling.
2	V_{TT}			Center tap for input termination. Leave floating for LVDS input, connect to 50Ω to GND for LVPECL inputs and to the V_{REF_AC} output for AC-coupled applications.
5, 16	GND	Power		Power supply ground.
8, 13	V_{DD}	Power		Power supply pins.

NOTE: *Pulldown* refer to internal input resistors. See Table 2, *Pin Characteristics*, for typical values.

Table 2. Pin Characteristics

Symbol	Parameter	Test Conditions	Minimum	Typical	Maximum	Units
C_{IN}	Input Capacitance			2		pF
$R_{PULLDOWN}$	Input Pulldown Resistor			51		k Ω

Device Configuration

Table 3A. Output Enable Control

Inputs		Outputs	
nOE1	nOE0	Q1, nQ1	Q0, nQ0
0 (default)	0 (default)	Enabled	Enabled
0	1	Enabled	Disabled (Logic 0)
1	0	Disabled (Logic 0)	Enabled
1	1	Disabled (Logic 0)	Disabled (Logic 0)

NOTE: nOEx are asynchronous controls.

Table 3B. Output Pre-Emphasis Control

Input		Pre-Emphasis	
PE1	PE0	Q1, nQ1	Q0, nQ0
0 (default)	0 (default)	Off	Off
0	1	Off	On
1	0	On	Off
1	1	On	On

NOTE: PEx are asynchronous controls.

Absolute Maximum Ratings

NOTE: Stresses beyond those listed under *Absolute Maximum Ratings* may cause permanent damage to the device. These ratings are stress specifications only. Functional operation of product at these conditions or any conditions beyond those listed in the *DC Characteristics* or *AC Characteristics* is not implied. Exposure to absolute maximum rating conditions for extended periods may affect product reliability.

Item	Rating
Supply Voltage, V_{DD}	4.6V
Inputs, V_I	-0.5V to $V_{DD} + 0.5V$
Outputs, I_O Continuous Current Surge Current	10mA 15mA
I_{IN} , Input Current, I_N , nIN	$\pm 50mA$
V_{TT} , Current, I_{VT}	$\pm 100mA$
V_{REF_AC} , Input Sink/Source Current, I_{REF_AC}	$\pm 2mA$
Package Thermal Impedance, θ_{JA}	74.7°C (0 mps)
Storage Temperature, T_{STG}	-65°C to 150°C

DC Electrical Characteristics

Table 4A. Power Supply DC Characteristics, $V_{DD} = 3.3V \pm 5\%$, $T_A = -40^\circ C$ to $85^\circ C$

Symbol	Parameter	Test Conditions	Minimum	Typical	Maximum	Units
V_{DD}	Power Supply Voltage		3.135	3.3	3.465	V
I_{DD}	Power Supply Current				90	mA

Table 4B. LVCMOS/LVTTL DC Characteristics, $V_{DD} = 3.3V \pm 5\%$, $T_A = -40^\circ C$ to $85^\circ C$

Symbol	Parameter	Test Conditions	Minimum	Typical	Maximum	Units
V_{IH}	Input High Voltage		2.2		$V_{DD} + 0.3$	V
V_{IL}	Input Low Voltage		-0.3		0.8	V
I_{IH}	Input High Current	PE0, PE1, nOE0, nOE1 $V_{DD} = V_{IN} = 3.465V$			150	μA
I_{IL}	Input Low Current	PE0, PE1, nOE0, nOE1 $V_{DD} = 3.465V, V_{IN} = 0V$	10			μA

Table 4C. DC Characteristics, $V_{DD} = 3.3V \pm 5\%$, $T_A = -40^{\circ}C$ to $85^{\circ}C$

Symbol	Parameter		Test Conditions	Minimum	Typical	Maximum	Units
R_{IN}	Input Resistance	IN, nIN	IN to V_{TT}	40	50	60	Ω
V_{IH}	Input High Voltage	IN, nIN		1.2		V_{DD}	V
V_{IL}	Input Low Voltage	IN, nIN		0		$V_{IH} - 0.15$	V
V_{IN}	Input Voltage Swing; NOTE 1			0.15		1.2	V
V_{DIFF_IN}	Differential Input Voltage Swing			0.3		2.4	V
V_{REF_AC}	Bias voltage reference			$V_{DD} - 1.35$	$V_{DD} - 1.30$	$V_{DD} - 1.25$	V
I_{IN}	Input Current; NOTE 2	IN, nIN				35	mA

NOTE 1: Refer to Parameter Measurement Information, Input Voltage Swing Diagram.

NOTE 2: Guaranteed by design.

Table 4D. LVDS DC Characteristics, $V_{DD} = 3.3V \pm 5\%$, $T_A = -40^{\circ}C$ to $85^{\circ}C$

Symbol	Parameter	Test Conditions	Minimum	Typical	Maximum	Units
V_{OD}	Differential Output Voltage	Pre-Emphasis off (PE0=PE1=0)	300	450	650	mV
ΔV_{OD}	V_{OD} Magnitude Change	Pre-Emphasis off (PE0=PE1=0)			50	mV
V_{OS}	Offset Voltage	Pre-Emphasis off (PE0=PE1=0)	1.10	1.25	1.40	V
ΔV_{OS}	V_{OS} Magnitude Change	Pre-Emphasis off (PE0=PE1=0)			50	mV

AC Electrical Characteristics

Table 5. AC Characteristics, $V_{DD} = 3.3V \pm 5\%$, $T_A = -40^\circ C$ to $+85^\circ C$

Symbol	Parameter	Test Conditions	Minimum	Typical	Maximum	Units
f_{REF}	Input Reference Frequency	Alternating 01 pattern (Clock)			3.0	GHz
f_{OUT}	Output Frequency	Alternating 01 pattern (Clock)			3.0	GHz
	Operating Data Rate	NRZ (PRBS 2^7-1 Pattern)			4.5	Gbps
t_{PD}	Propagation Delay; NOTE 1	Alternating 01 pattern (Clock)	300		500	ps
$t_{sk(p)}$	Output Pulse Skew	Alternating 01 pattern (Clock)			20	ps
$t_{sk(o)}$	Output Skew, NOTE 2, 4	Alternating 01 pattern (Clock)			10	ps
$t_{sk(pp)}$	Part-to-Part Skew: NOTE 3, 4	Alternating 01 pattern (Clock)			150	ps
t_{EN}	Output Enable Time: NOTE 5				1.25	ns
t_{DIS}	Output Disable Time: NOTE 5				1.35	ns
V_{PE}	Output Pre-Emphasis Voltage Ratio; NOTE 5	$f_{OUT} = 300MHz$, Pre-Emphasis Off		0		dB
		$f_{OUT} = 300MHz$, Pre-Emphasis On		2		dB
Δt_{PE}	Output Pre-Emphasis Duration; NOTE 5	$f_{OUT} = 300MHz$, Pre-Emphasis On		300		ps
f_{jit}	Buffer Additive Phase Jitter, RMS; refer to Additive Phase Jitter section	Alternating 01 pattern (Clock), 491.52MHz, Integration Range: 12kHz - 20MHz		0.08		ps
t_{DJ}	Deterministic Jitter Peak-Peak; NOTE 5, 6	K28.5 Pattern, 1.5 Gbps, Pre-Emphasis On			4	ps
t_{TJ}	Total Jitter Peak-Peak; NOTE 5	NRZ (PRBS 2^7-1 Pattern), 1.5 Gbps, Pre-Emphasis On			4	ps
t_R / t_F	Output Rise/ Fall Time	$f_{OUT} \leq 625MHz$		50	400	ps
		$f_{OUT} = 1.25GHz$	20% to 80%, 491.52MHz Alternating 01 pattern (Clock)	65	200	ps
		$f_{OUT} = 2.25GHz$		80	100	ps

NOTE: Electrical parameters are guaranteed over the specified ambient operating temperature range, which is established when the device is mounted in a test socket with maintained transverse airflow greater than 500 lfpm. The device will meet specifications after thermal equilibrium has been reached under these conditions.

NOTE: All parameters characterized at $f_{OUT} \leq 1.25GHz$ and pre-emphasis off, unless otherwise noted.

NOTE 1: Measured from the differential input crossing point to the differential output crossing point.

NOTE 2: Defined as skew between outputs at the same supply voltages and with equal load conditions. Measured at the output differential cross points.

NOTE 3: Defined as skew between outputs on different devices operating at the same supply voltage, same temperature, same frequency, and with equal load conditions. Using the same type of inputs on each device, the outputs are measured at the differential cross points.

NOTE 4: This parameter is defined according with JEDEC Standard 65.

NOTE 5: These parameters are guaranteed by characterization.

NOTE 6: A repeating K28.5 sequence (composed of alternating K28.5+ and K28.5-) contains the symbols 0011111010 1100000101. This pattern contains five consecutive 1's and five consecutive 0's, (the longest consecutive identical digits found in 8B/10B coded data)

Additive Phase Jitter

The spectral purity in a band at a specific offset from the fundamental compared to the power of the fundamental is called the **dBc Phase Noise**. This value is normally expressed using a Phase noise plot and is most often the specified plot in many applications. Phase noise is defined as the ratio of the noise power present in a 1Hz band at a specified offset from the fundamental frequency to the power value of the fundamental. This ratio is expressed in decibels (dBm) or a ratio

of the power in the 1Hz band to the power in the fundamental. When the required offset is specified, the phase noise is called a **dBc** value, which simply means dBm at a specified offset from the fundamental. By investigating jitter in the frequency domain, we get a better understanding of its effects on the desired application over the entire time record of the signal. It is mathematically possible to calculate an expected bit error rate given a phase noise plot.

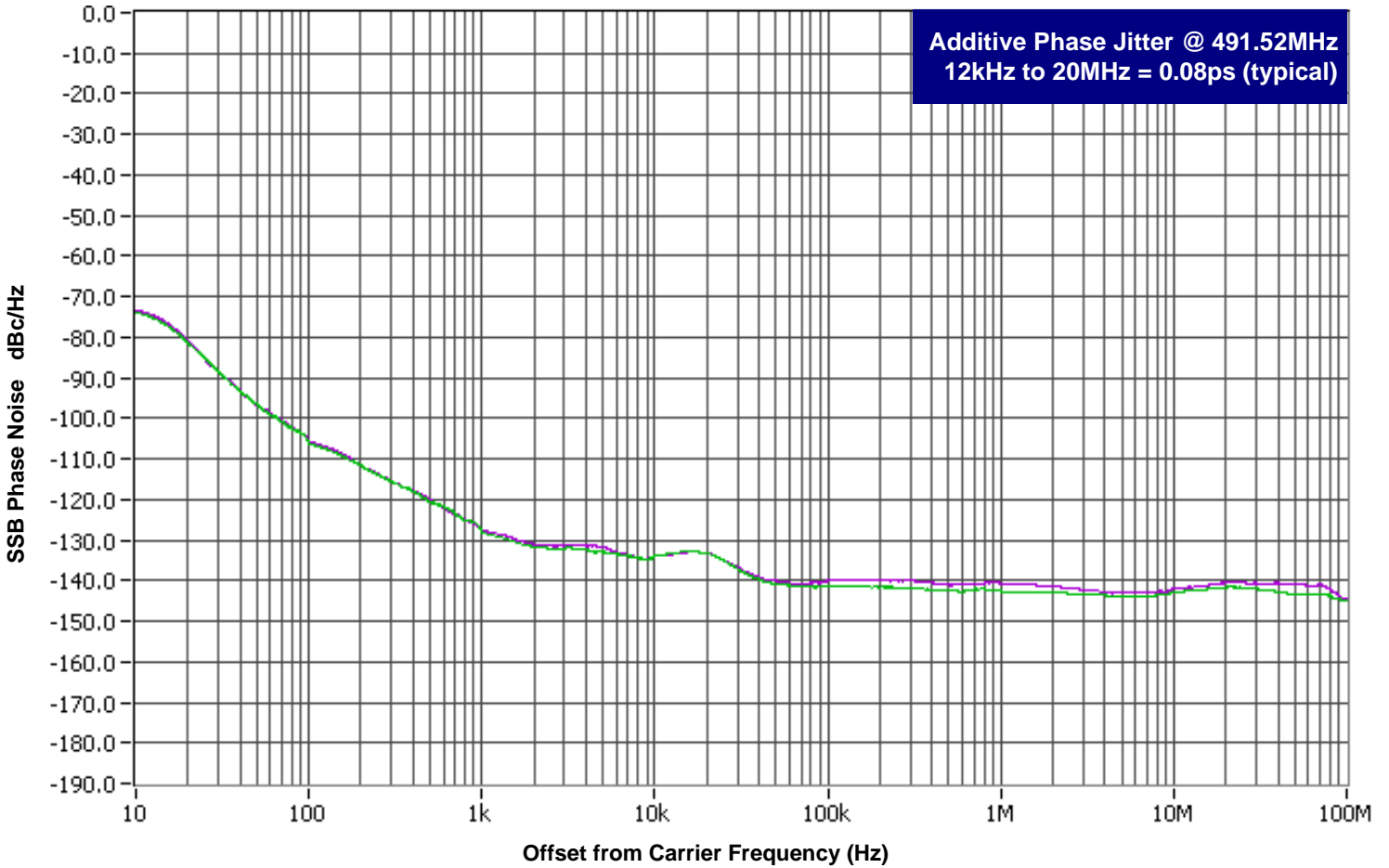

As with most timing specifications, phase noise measurements have issues relating to the limitations of the equipment. Often the noise floor of the equipment is higher than the noise floor of the device. This is illustrated above. The device meets the noise floor of what is shown, but can actually be lower. The phase noise is dependent on the input source and measurement equipment.

The source generator "IFR2042 10kHz – 6.4GHz Low Noise Signal Generator as external input to an Agilent 8133A 3GHz Pulse Generator".

Parameter Measurement Information

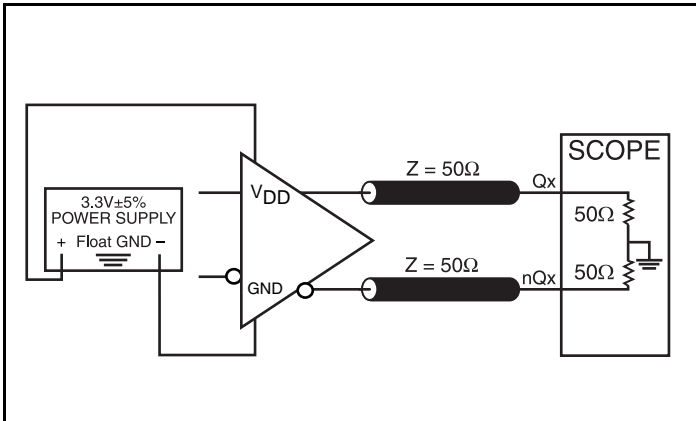

LVDS Output Load AC Test Circuit

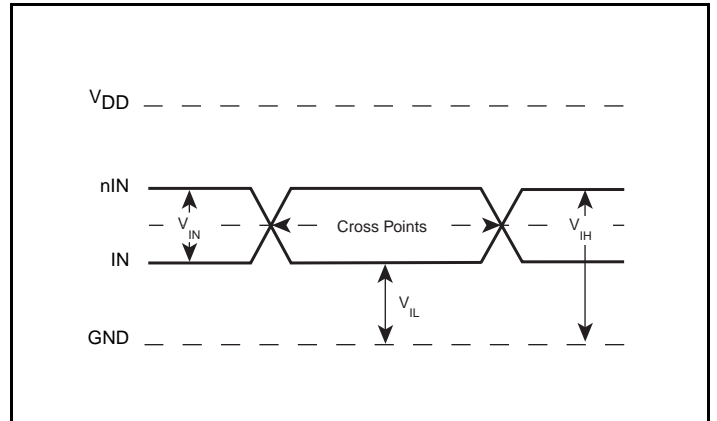

Differential Input Level

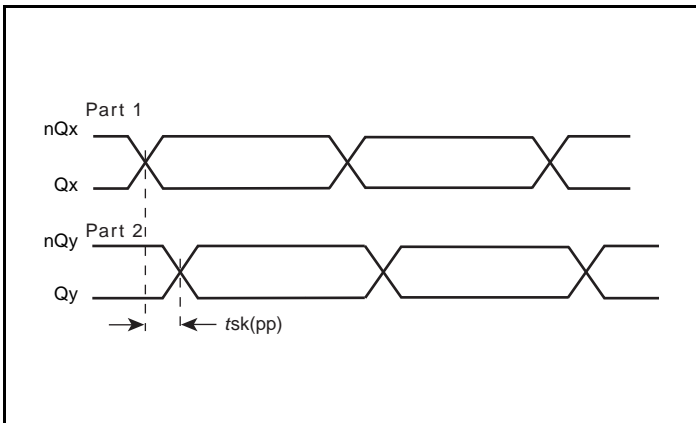

Part-to-Part Skew

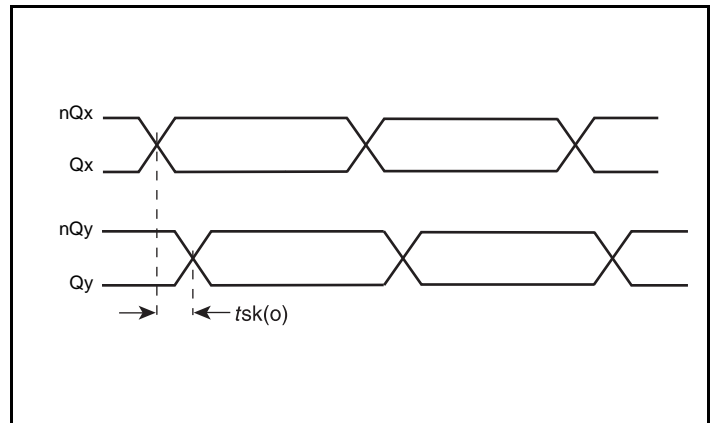

Output Skew

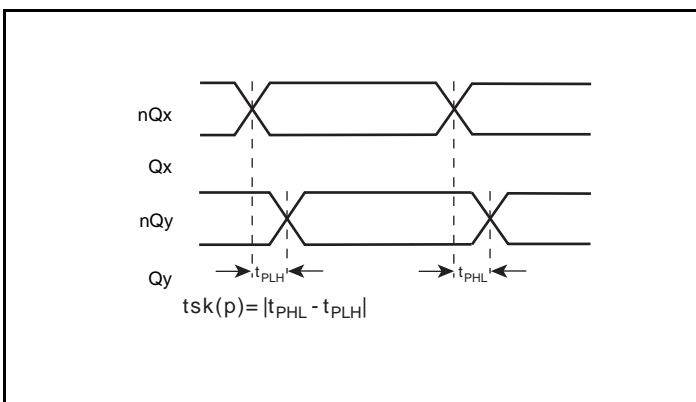

Output Pulse Skew

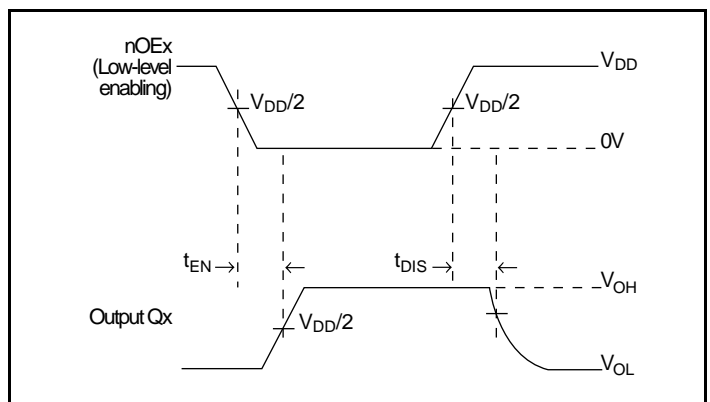

Output Enable/Disable Time

Parameter Measurement Information, continued

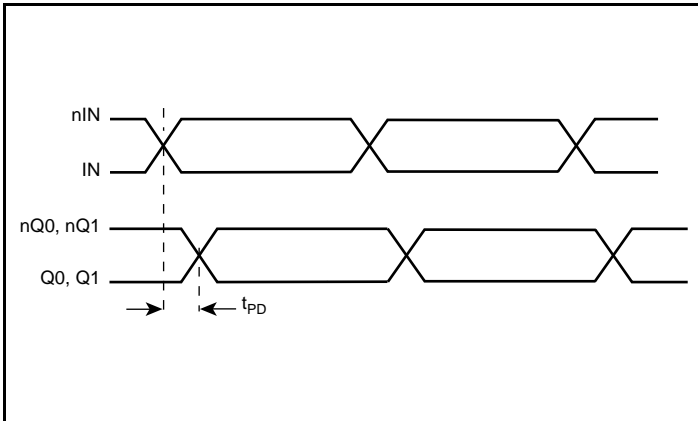

Propagation Delay

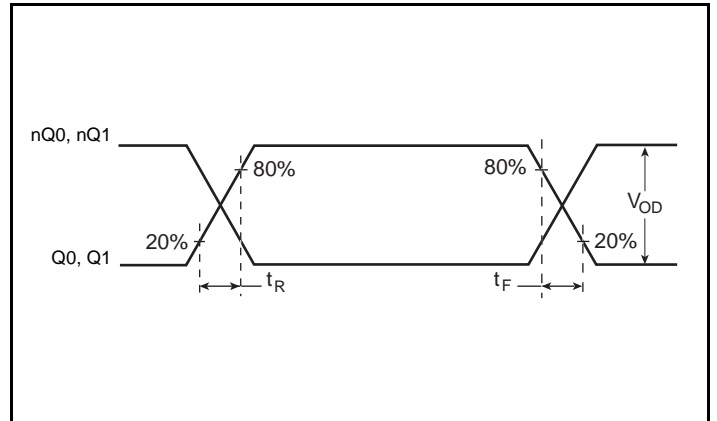

Output Rise/Fall Time

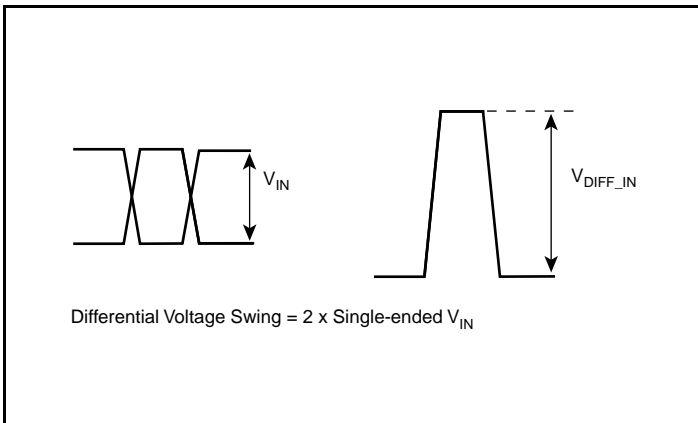

Single-Ended & Differential Input Voltage Swing

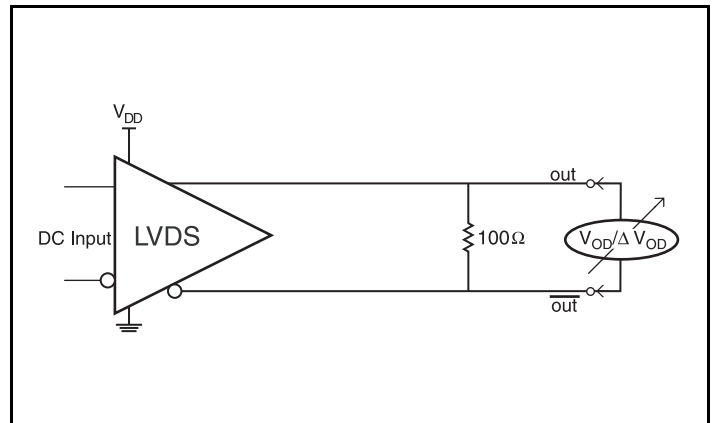

Differential Output Voltage Setup

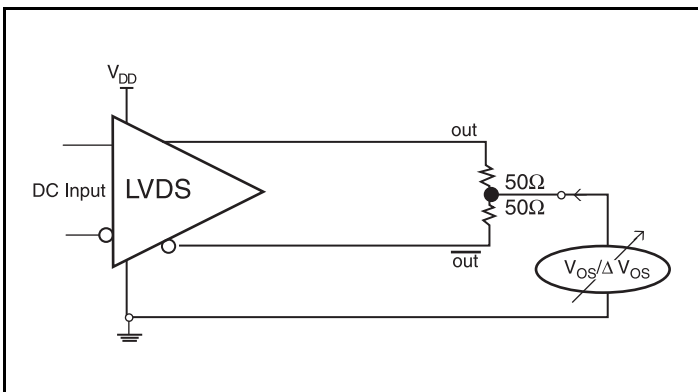

Offset Voltage Setup

Parameter Measurement Information, continued

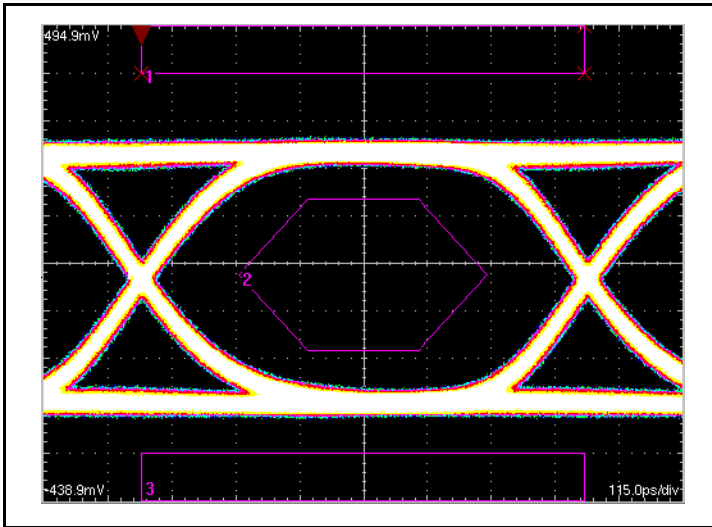

1.2GHz NRZ (PRBS Pattern) GbE Mask, Pre-Emphasis On

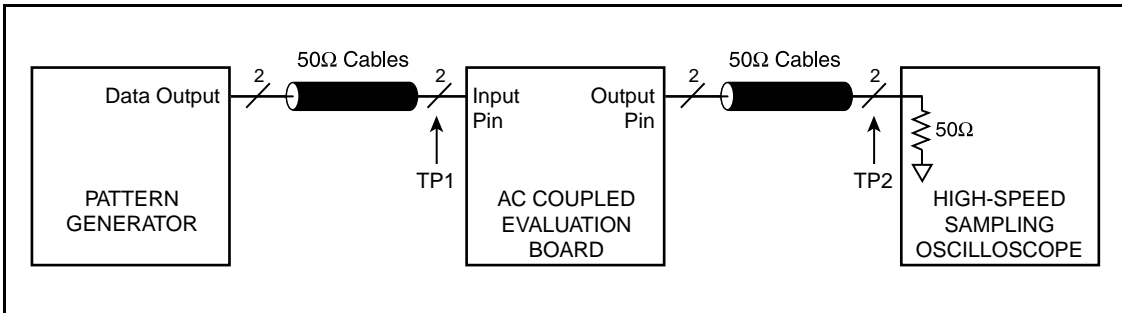

Deterministic Jitter and Total Jitter (peak-to-peak)

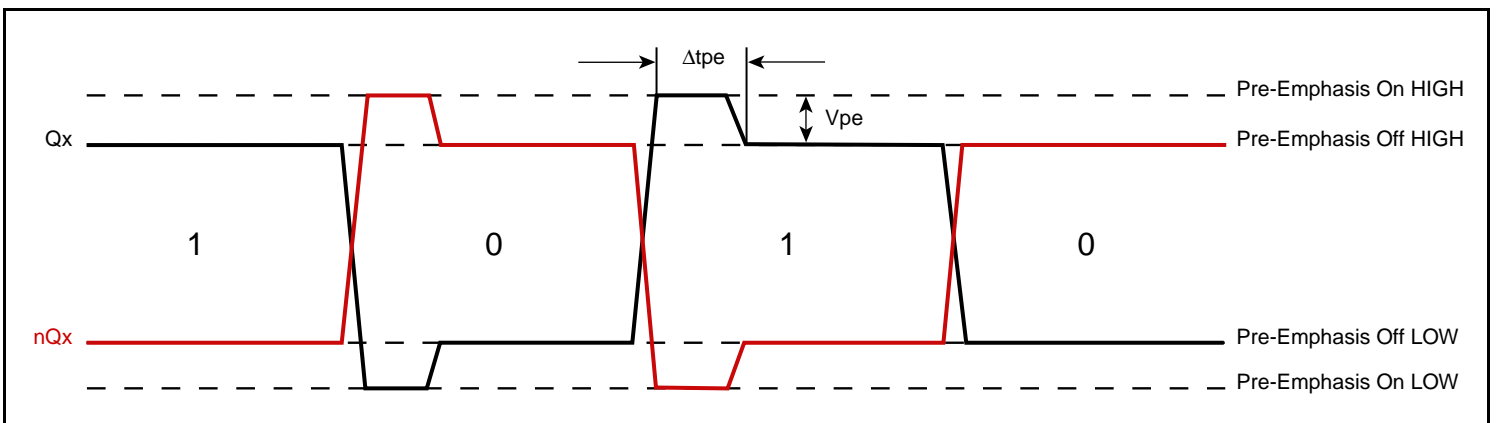

Output Pre-Emphasis Voltage Ratio & Duration

Applications Information

3.3V Differential Input with Built-In 50Ω Termination Interface

The IN/nIN with built-in 50Ω terminations accept LVDS, LVPECL, CML and other differential signals. Both V_{SWING} and V_{OH} must meet the V_{IN} and V_{IH} input requirements. *Figure 1A* to *Figure 1D* show interface examples for the IN/nIN input with built-in 50Ω terminations driven by the most common driver types. The input interfaces

suggested here are examples only. If the driver is from another vendor, use their termination recommendation. Please consult with the vendor of the driver component to confirm the driver termination requirements.

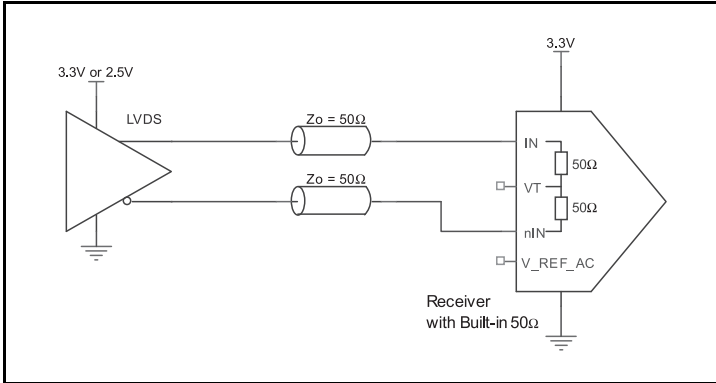

Figure1A. IN/nIN Input with Built-In 50Ω Driven by an LVDS Driver

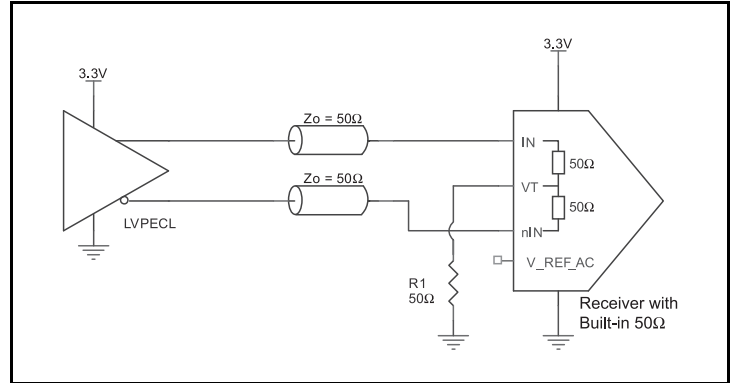

Figure1C. IN/nIN Input with Built-In 50Ω Driven by an LVPECL Driver

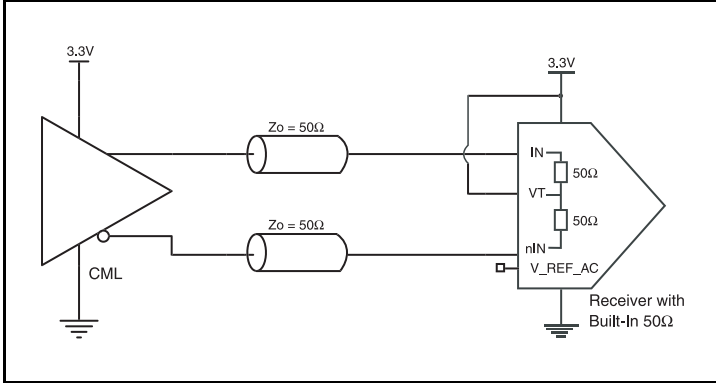

Figure1B. IN/nIN Input with Built-In 50Ω Driven by a CML Driver with Open Collector

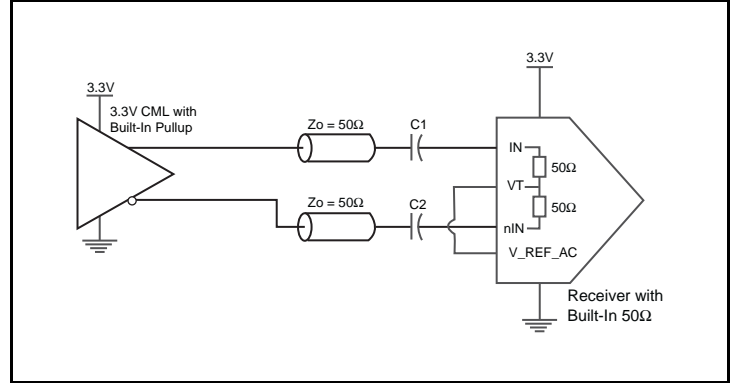

Figure1D. IN/nIN Input with Built-In 50Ω Driven by a CML Driver with Built-In 50Ω Pullup

Recommendations for Unused Input and Output Pins

Inputs

LVCMOS Select Pins

All control pins have internal pulldowns; additional resistance is not required but can be added for additional protection. A 1kΩ resistor can be used.

Outputs

LVDS Outputs

All unused LVDS output pairs can be either left floating or terminated with 100Ω across. If they are left floating, we recommend that there is no trace attached.

LVDS Driver Termination

For a general LVDS interface, the recommended value for the termination impedance (Z_T) is between 90Ω and 132Ω. The actual value should be selected to match the differential impedance (Z_0) of your transmission line. A typical point-to-point LVDS design uses a 100Ω parallel resistor at the receiver and a 100Ω differential transmission-line environment. In order to avoid any transmission-line reflection issues, the components should be be surface mounted and must be placed as close to the receiver as possible. IDT offers a full line of LVDS compliant devices with two types of output structures: current source and voltage source. The standard termination schematic as shown in [Figure 2A](#) can be used

with either type of output structure. [Figure 2B](#), which can also be used with both output types, is an optional termination with center tap capacitance to help filter common mode noise. The capacitor value should be approximately 50pF. If using a non-standard termination, it is recommended to contact IDT and confirm if the output structure is current source or voltage source type. In addition, since these outputs are LVDS compatible, the input receiver's amplitude and common-mode input range should be verified for compatibility with the output.

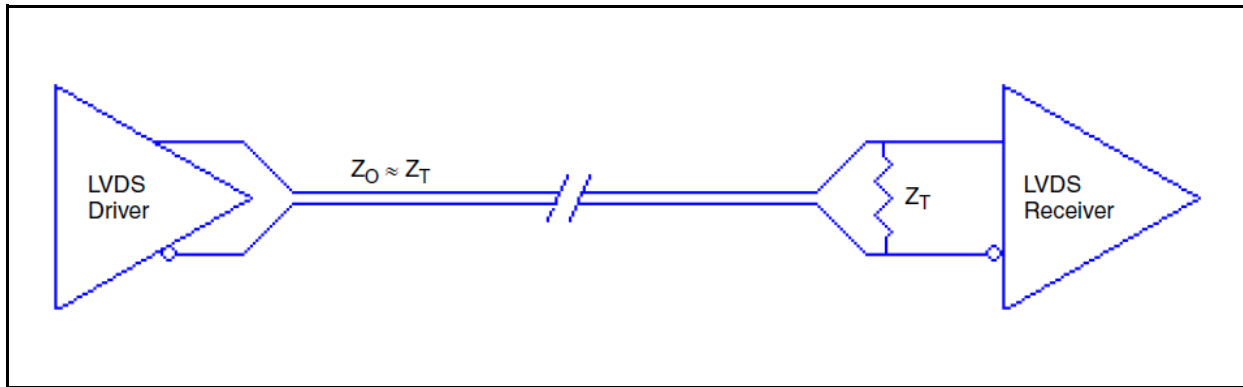

Figure2A. Standard LVDS Termination

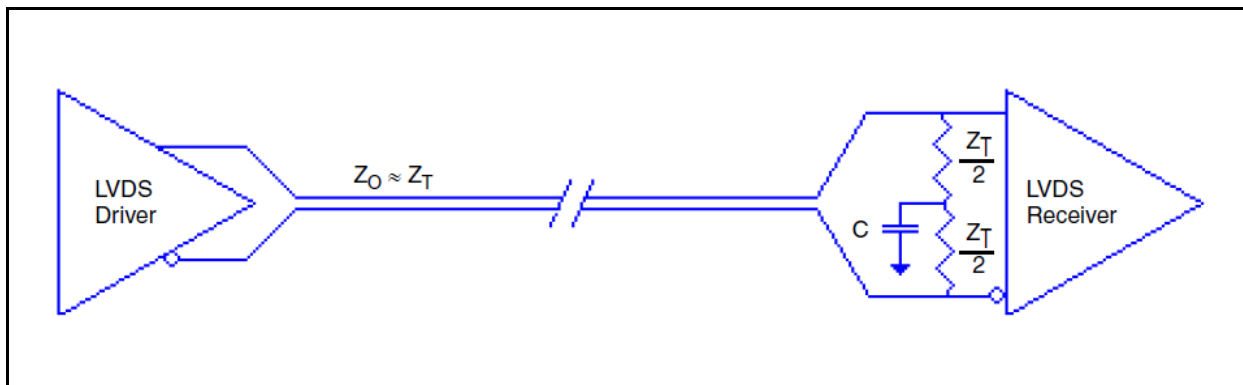

Figure2B. Optional LVDS Termination

VFQFN EPAD Thermal Release Path

In order to maximize both the removal of heat from the package and the electrical performance, a land pattern must be incorporated on the Printed Circuit Board (PCB) within the footprint of the package corresponding to the exposed metal pad or exposed heat slug on the package, as shown in [Figure 3](#). The solderable area on the PCB, as defined by the solder mask, should be at least the same size/shape as the exposed pad/slug area on the package to maximize the thermal/electrical performance. Sufficient clearance should be designed on the PCB between the outer edges of the land pattern and the inner edges of pad pattern for the leads to avoid any shorts.

While the land pattern on the PCB provides a means of heat transfer and electrical grounding from the package to the board through a solder joint, thermal vias are necessary to effectively conduct from the surface of the PCB to the ground plane(s). The land pattern must be connected to ground through these vias. The vias act as “heat pipes”. The number of vias (i.e. “heat pipes”) are application specific

and dependent upon the package power dissipation as well as electrical conductivity requirements. Thus, thermal and electrical analysis and/or testing are recommended to determine the minimum number needed. Maximum thermal and electrical performance is achieved when an array of vias is incorporated in the land pattern. It is recommended to use as many vias connected to ground as possible. It is also recommended that the via diameter should be 12 to 13mils (0.30 to 0.33mm) with 1oz copper via barrel plating. This is desirable to avoid any solder wicking inside the via during the soldering process which may result in voids in solder between the exposed pad/slug and the thermal land. Precautions should be taken to eliminate any solder voids between the exposed heat slug and the land pattern. Note: These recommendations are to be used as a guideline only. For further information, please refer to the Application Note on the Surface Mount Assembly of Amkor’s Thermally/Electrically Enhance Leadframe Base Package, Amkor Technology.

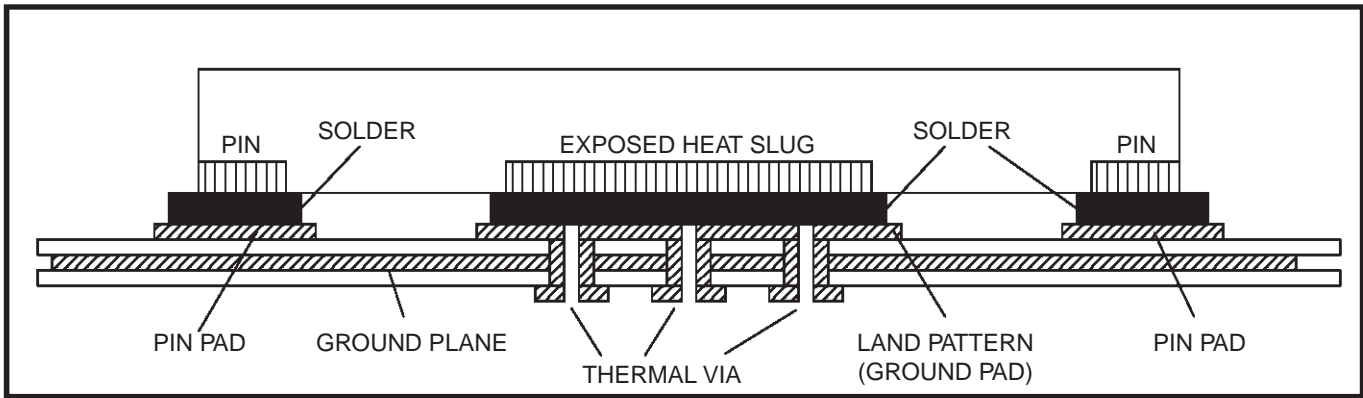

Figure 3. P.C. Assembly for Exposed Pad Thermal Release Path – Side View (drawing not to scale)

Power Considerations

This section provides information on power dissipation and junction temperature for the 854S712. Equations and example calculations are also provided.

1. Power Dissipation.

The total power dissipation for the 854S712 is the sum of the core power plus the power dissipated into the load. The following is the power dissipation for $V_{DD} = 3.3V + 5\% = 3.465V$, which gives worst case results.

NOTE: Please refer to Section 3 for details on calculating power dissipated in the load.

- Power (core)_{MAX} = $V_{DD_MAX} * I_{DD_MAX} = 3.465V * 90mA = 311.85mW$
- Power Dissipation for internal termination R_T
Power (R_T)_{MAX} = $(V_{IN_MAX})^2 / R_{T_MIN} = (1.2V)^2 / 80\Omega = 18mW$

Total Power_{MAX} = 311.85mW + 18mW = **329.85mW**

2. Junction Temperature.

Junction temperature, T_j, is the temperature at the junction of the bond wire and bond pad directly affects the reliability of the device. The maximum recommended junction temperature is 125°C. Limiting the internal transistor junction temperature, T_j, to 125°C ensures that the bond wire and bond pad temperature remains below 125°C.

The equation for T_j is as follows: $T_j = \theta_{JA} * Pd_total + T_A$

T_j = Junction Temperature

θ_{JA} = Junction-to-Ambient Thermal Resistance

Pd_{total} = Total Device Power Dissipation (example calculation is in section 1 above)

T_A = Ambient Temperature

In order to calculate junction temperature, the appropriate junction-to-ambient thermal resistance θ_{JA} must be used. Assuming no air flow and a multi-layer board, the appropriate value is 74.7°C/W per Table 6 below.

Therefore, T_j for an ambient temperature of 85°C with all outputs switching is:

$$85^\circ C + 0.330W * 74.7^\circ C/W = 109.7^\circ C. \text{ This is below the limit of } 125^\circ C.$$

This calculation is only an example. T_j will obviously vary depending on the number of loaded outputs, supply voltage, air flow and the type of board (multi-layer).

Table 6. Thermal Resistance θ_{JA} for 16 Lead VFQFN, Forced Convection

θ_{JA} by Velocity			
Meters per Second	0	1	2.5
Multi-Layer PCB, JEDEC Standard Test Boards	74.7°C/W	65.3°C/W	58.5°C/W

Reliability Information

Table 7. θ_{JA} vs. Air Flow Table for a 16 Lead VFQFN

θ_{JA} by Velocity			
Meters per Second	0	1	2.5
Multi-Layer PCB, JEDEC Standard Test Boards	74.7°C/W	65.3°C/W	58.5°C/W

Transistor Count

The transistor count for 854S712 is: 439

Package Outline Drawings

The package outline drawings are located at the end of this document. The package information is the most current data available and is subject to change without notice or revision of this document.

Ordering Information

Part/Order Number	Marking	Package	Shipping Packaging	Temperature
854S712AKILF	2AIL	16 Lead VFQFN, Lead-Free	Tray	-40°C to 85°C
854S712AKILFT	2AIL	16 Lead VFQFN, Lead-Free	Tape & Reel	-40°C to 85°C

NOTE: Parts that are ordered with an "LF" suffix to the part number are the Pb-Free configuration and are RoHS compliant.

Revision History

Revision Date	Description of Change
October 10, 2017	Updated the package outline drawings; however, no mechanical changes Completed other minor improvements
December 18, 2014	Updated "Wiring the Differential output" application section. Updated LVDS Termination. Updated header/footer throughout the datasheet.

16L-QFN Package Outline Drawing

3.0 x 3.0 x 1.0 mm, 0.5 mm Pitch, 1.70 x 1.70 mm Epad
 NL/NLG16P2, PSC-4169-02, Rev 03, Page 1

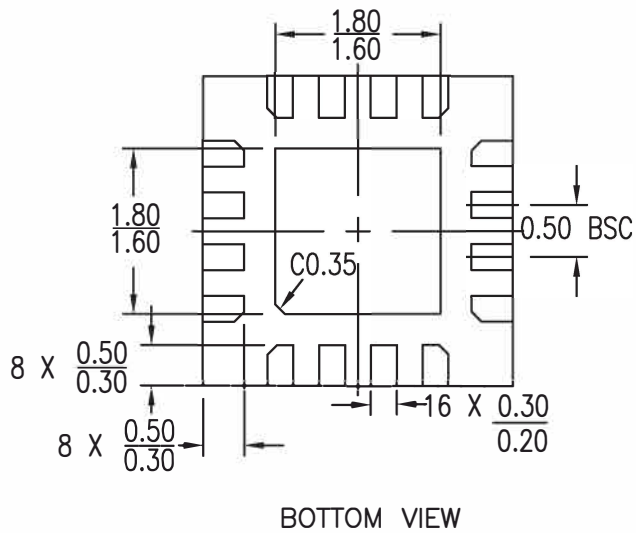
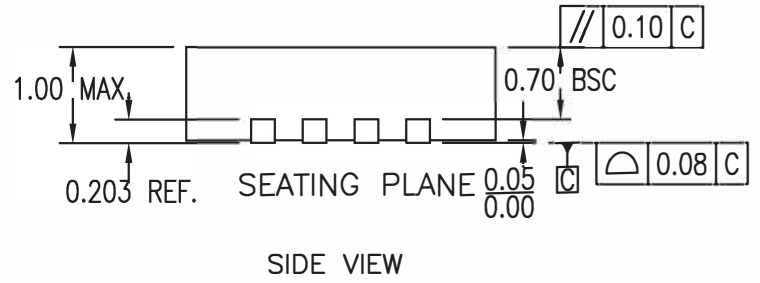
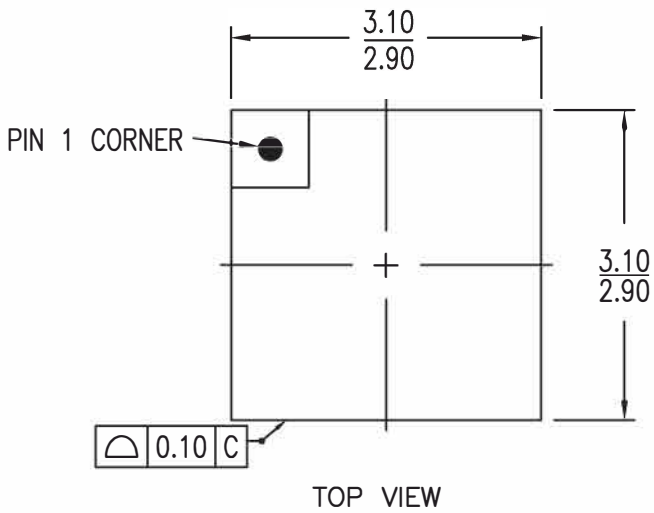

NOTES:
 1. ALL DIMENSIONS ARE IN mm.ANGLES IN DEGREES

16L-QFN Package Outline Drawing

3.0 x 3.0 x 1.0 mm, 0.5 mm Pitch, 1.70 x 1.70 mm Epad

NL/NLG16P2, PSC-4169-02, Rev 03, Page 2

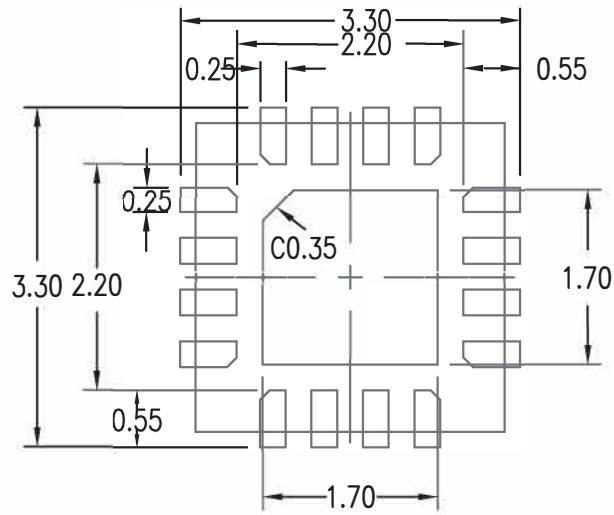

IMPORTANT NOTICE AND DISCLAIMER

RENESAS ELECTRONICS CORPORATION AND ITS SUBSIDIARIES (“RENESAS”) PROVIDES TECHNICAL SPECIFICATIONS AND RELIABILITY DATA (INCLUDING DATASHEETS), DESIGN RESOURCES (INCLUDING REFERENCE DESIGNS), APPLICATION OR OTHER DESIGN ADVICE, WEB TOOLS, SAFETY INFORMATION, AND OTHER RESOURCES “AS IS” AND WITH ALL FAULTS, AND DISCLAIMS ALL WARRANTIES, EXPRESS OR IMPLIED, INCLUDING, WITHOUT LIMITATION, ANY IMPLIED WARRANTIES OF MERCHANTABILITY, FITNESS FOR A PARTICULAR PURPOSE, OR NON-INFRINGEMENT OF THIRD-PARTY INTELLECTUAL PROPERTY RIGHTS.

These resources are intended for developers who are designing with Renesas products. You are solely responsible for (1) selecting the appropriate products for your application, (2) designing, validating, and testing your application, and (3) ensuring your application meets applicable standards, and any other safety, security, or other requirements. These resources are subject to change without notice. Renesas grants you permission to use these resources only to develop an application that uses Renesas products. Other reproduction or use of these resources is strictly prohibited. No license is granted to any other Renesas intellectual property or to any third-party intellectual property. Renesas disclaims responsibility for, and you will fully indemnify Renesas and its representatives against, any claims, damages, costs, losses, or liabilities arising from your use of these resources. Renesas' products are provided only subject to Renesas' Terms and Conditions of Sale or other applicable terms agreed to in writing. No use of any Renesas resources expands or otherwise alters any applicable warranties or warranty disclaimers for these products.

(Disclaimer Rev.1.01 Jan 2024)

Corporate Headquarters

TOYOSU FORESIA, 3-2-24 Toyosu,
Koto-ku, Tokyo 135-0061, Japan
www.renesas.com

Trademarks

Renesas and the Renesas logo are trademarks of Renesas Electronics Corporation. All trademarks and registered trademarks are the property of their respective owners.

Contact Information

For further information on a product, technology, the most up-to-date version of a document, or your nearest sales office, please visit www.renesas.com/contact-us/.

Looking for pricing, stock, or lifecycle information?

Click below to explore more details on WIN SOURCE:

-  [View 854S712AKILF on WIN SOURCE](#)
-  [Renesas Electronics America](#) Information

Optimize Your Supply Chain with WIN SOURCE Solutions

-  Global Sourcing Solution
-  Obsolete Management
-  Cost Control Management
-  Shortage Management
-  Alternative Solution
-  Excess Inventory Management