



**THE DATASHEET OF  
854S015CKI-01LF**



### General Description

The ICS854S015I-01 is a low skew, high performance 1-to-5, 2.5V, 3.3V Differential-to-LVPECL/LVDS Fanout Buffer. The ICS854S015I-01 has two selectable differential clock inputs.

Guaranteed output and part-to-part skew characteristics make the ICS854S015I-01 ideal for those applications demanding well defined performance and repeatability.

### Features

- Five differential LVPECL or LVDS output pairs
- Two differential clock input pairs
- CLK, nCLK pair can accept the following differential input levels: LVDS, LVPECL, LVHSTL, HCSL
- PCLK, nPCLK can accept the following input levels: LVPECL, LVDS, CML
- Either CLK or PCLK inputs can be configured to accept single-ended inputs
- Maximum output frequency: 2GHz
- Additive phase jitter, RMS: 0.065ps (maximum), 3.3V, 156.25MHz, 12kHz – 5MHz)
- Output Skew: 55ps (maximum)
- Propagation delay: 570ps (typical) @ 3.3V
- Full 3.3V or 2.5V supply modes
- -40°C to 85°C ambient operating temperature
- Available in lead-free (RoHS 6) package

### Block Diagram

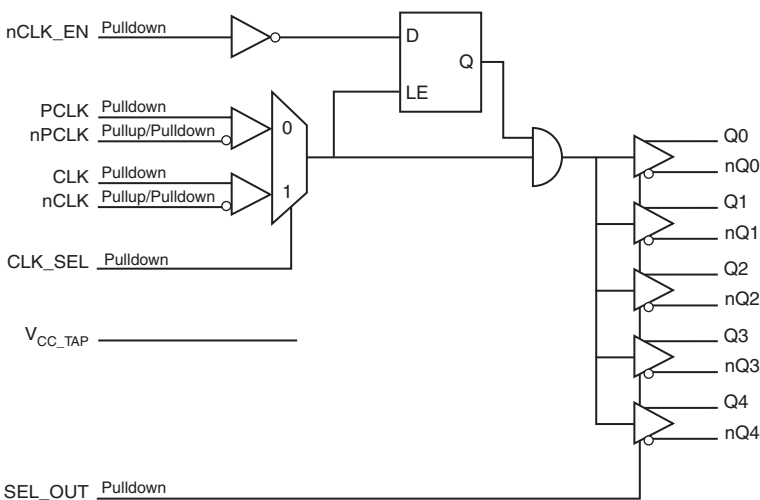

### Pin Assignment

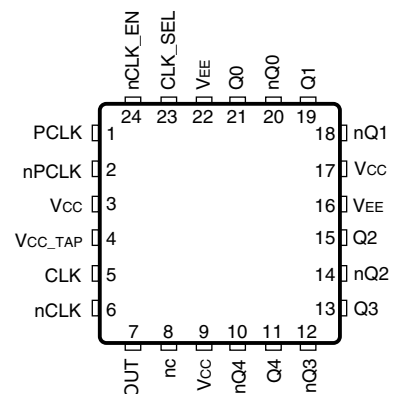

ICS854S015I-01

24-Lead VFQFN

4mm x 4mm x 0.925mm package body

K Package

Top View

**Table 1. Pin Descriptions**

Number	Name	Type		Description
1	PCLK	Input	Pulldown	Non-inverting differential LVPECL clock input.
2	nPCLK	Input	Pullup/ Pulldown	Inverting differential LVPECL clock input. $V_{CC}/2$ default when left floating.
3, 9, 17	$V_{CC}$	Power		Positive supply pins.
4	$V_{CC\_TAP}$	Power		Power supply pin. See Table 3C.
5	CLK	Input	Pulldown	Non-inverting differential clock input.
6	nCLK	Input	Pullup/ Pulldown	Inverting differential clock input. $V_{CC}/2$ default when left floating.
7	SEL_OUT	Input	Pulldown	Output select pin. When LOW, selects LVDS output levels. When HIGH, selects LVPECL output levels. See Table 3. LVCMOS/LVTTL interface levels.
8	nc	Unused		No-connect.
10, 11	nQ4, Q4	Output		Differential output pair. LVDS or LVPECL interface levels.
12, 13	nQ3, Q3	Output		Differential output pair. LVDS or LVPECL interface levels.
14, 15	nQ2, Q2	Output		Differential output pair. LVDS or LVPECL interface levels.
16, 22	$V_{EE}$	Power		Negative supply pins.
18, 19	nQ1, Q1	Output		Differential output pair. LVDS or LVPECL interface levels.
20, 21	nQ0, Q0	Output		Differential output pair. LVDS or LVPECL interface levels.
23	CLK_SEL	Input	Pulldown	Clock select input. When HIGH, selects CLK, nCLK inputs. When LOW, selects PCLK, nPCLK inputs. LVTTL / LVCMOS interface levels.
24	nCLK_EN	Input	Pulldown	Synchronizing clock enable. When LOW, clock outputs follow clock input. When HIGH, Qx outputs are forced low, nQx outputs are forced high. LVTTL / LVCMOS interface levels.

NOTE: Pullup and Pulldown refer to internal input resistors. See Table 2, *Pin Characteristics*, for typical values.

**Table 2. Pin Characteristics**

Symbol	Parameter	Test Conditions	Minimum	Typical	Maximum	Units
$C_{IN}$	Input Capacitance			2		pF
$R_{PULLDOWN}$	Input Pulldown Resistor			50		k $\Omega$
$R_{V_{CC}/2}$	Pullup/Pulldown Resistor			50		k $\Omega$

## Function Tables

**Table 3A. Control Input Function Table**

Inputs			Outputs	
nCLK_EN	CLK_SEL	Selected Source	Q[0:4]	nQ[0:4]
0	0	PCLK, nPCLK	Enabled	Enabled
0	1	CLK, nCLK	Enabled	Enabled
1	0	PCLK, nPCLK	Disabled; Low	Disabled; High
1	1	CLK, nCLK	Disabled; Low	Disabled; High

After nCLK\_EN switches, the clock outputs are disabled or enabled following a falling input clock edge as shown in Figure 1. In the active mode, the state of the outputs are a function of the PCLK, nPCLK and CLK, nCLK inputs as described in Table 3B.

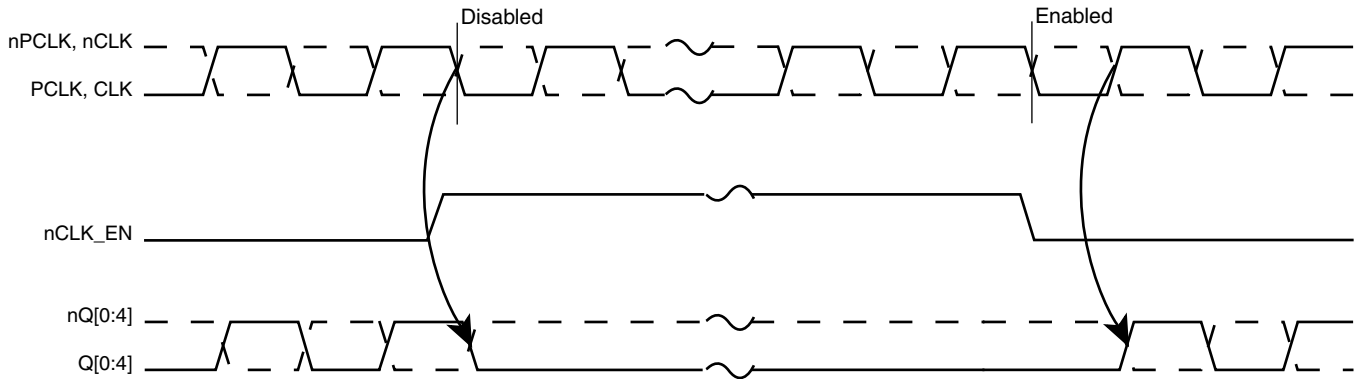

**Figure 1. nCLK\_EN Timing Diagram**

**Table 3B. Clock Input Function Table**

Inputs		Outputs		Input to Output Mode	Polarity
PCLK or CLK	nPCLK or nCLK	Q[0:4]	nQ[0:4]		
0	1	LOW	HIGH	Differential to Differential	Non-Inverting
1	0	HIGH	LOW	Differential to Differential	Non-Inverting

**Table 3C. V<sub>CC\_TAP</sub> Function Table**

Outputs	Output Level Supply	V <sub>CC_TAP</sub>
Q[0:4], nQ[0:4]		
LVPECL	2.5V	2.5V
LVPECL	<b>3.3V</b>	<b>3.3V</b>
LVDS	2.5V	2.5V
LVDS	3.3V	Float

**Table 3D. SEL\_OUT Function Table**

Input	Outputs
SEL_OUT	Q[0:4], nQ[0:4]
0 (default)	LVDS
1	LVPECL

## Absolute Maximum Ratings

NOTE: Stresses beyond those listed under *Absolute Maximum Ratings* may cause permanent damage to the device. These ratings are stress specifications only. Functional operation of product at these conditions or any conditions beyond those listed in the *DC Characteristics* or *AC Characteristics* is not implied. Exposure to absolute maximum rating conditions for extended periods may affect product reliability.

Item	Rating
Supply Voltage, $V_{CC}$	4.6V
Inputs, $V_I$	-0.5V to $V_{CC} + 0.5V$
Outputs, $I_O$ (LVPECL) Continuous Current Surge Current	50mA 100mA
Outputs, $I_O$ (LVDS) Continuous Current Surge Current	10mA 15mA
Package Thermal Impedance, $\theta_{JA}$	49.5°C/W (0 mps)
Storage Temperature, $T_{STG}$	-65°C to 150°C

## DC Electrical Characteristics

**Table 4A. LVPECL Power Supply DC Characteristics,  $V_{CC} = V_{CC\_TAP} = 3.3V \pm 5\%$ ,  $V_{EE} = 0V$ ,  $T_A = -40^\circ C$  to  $85^\circ C$**

Symbol	Parameter	Test Conditions	Minimum	Typical	Maximum	Units
$V_{CC}$	Positive Supply Voltage		3.135	3.3	3.465	V
$V_{CC\_TAP}$	Power Supply Voltage		3.135	3.3	3.465	V
$I_{EE}$	Power Supply Current				85	mA
$I_{TAP}$	Power Supply Current				5	mA

**Table 4B. LVPECL Power Supply DC Characteristics,  $V_{CC} = V_{CC\_TAP} = 2.5V \pm 5\%$ ,  $V_{EE} = 0V$ ,  $T_A = -40^\circ C$  to  $85^\circ C$**

Symbol	Parameter	Test Conditions	Minimum	Typical	Maximum	Units
$V_{CC}$	Positive Supply Voltage		2.375	2.5	2.625	V
$V_{CC\_TAP}$	Power Supply Voltage		2.375	2.5	2.625	V
$I_{EE}$	Power Supply Current				78	mA
$I_{TAP}$	Power Supply Current				5	mA

**Table 4C. LVDS Power Supply DC Characteristics,  $V_{CC} = 3.3V \pm 5\%$ ,  $T_A = -40^{\circ}C$  to  $85^{\circ}C$** 

Symbol	Parameter	Test Conditions	Minimum	Typical	Maximum	Units
$V_{CC}$	Positive Supply Voltage		3.135	3.3	3.465	V
$I_{CC}$	Power Supply Current				160	mA

NOTE:  $V_{CC\_TAP}$  is left floating for 3.3V operation.

**Table 4D. LVDS Power Supply DC Characteristics,  $V_{CC} = V_{CC\_TAP} = 2.5V \pm 5\%$ ,  $V_{EE} = 0V$ ,  $T_A = -40^{\circ}C$  to  $85^{\circ}C$** 

Symbol	Parameter	Test Conditions	Minimum	Typical	Maximum	Units
$V_{CC}$	Positive Supply Voltage		2.375	2.5	2.625	V
$V_{CC\_TAP}$	Power Supply Voltage		2.375	2.5	2.625	V
$I_{CC}$	Power Supply Current				150	mA
$I_{CC\_TAP}$	Power Supply Current				5	mA

**Table 4E. LVCMOS/LVTTL DC Characteristics,  $V_{CC} = 3.3V \pm 5\%$  or  $V_{CC} = V_{CC\_TAP} = 2.5V \pm 5\%$ ,  $V_{EE} = 0V$ ,  $T_A = -40^{\circ}C$  to  $85^{\circ}C$** 

Symbol	Parameter	Test Conditions	Minimum	Typical	Maximum	Units
$V_{IH}$	Input High Voltage	$V_{CC} = 3.465V$	2.2		$V_{CC} + 0.3$	V
		$V_{CC} = 2.625V$	1.7		$V_{CC} + 0.3$	V
$V_{IL}$	Input Low Voltage	$V_{CC} = 3.465V$	-0.3		0.8	V
		$V_{CC} = 2.625V$	-0.3		0.7	V
$I_{IH}$	Input High Current	CLK_SEL, SEL_OUT, nCLK_EN $V_{CC} = V_{IN} = 3.465V$ or $2.625V$			150	$\mu A$
$I_{IL}$	Input Low Current	CLK_SEL, SEL_OUT, nCLK_EN $V_{CC} = 3.465V$ or $2.625V$ , $V_{IN} = 0V$	-10			$\mu A$

**Table 4F. Differential DC Characteristics,  $V_{CC} = 3.3V \pm 5\%$  or  $V_{CC} = V_{CC\_TAP} = 2.5V \pm 5\%$ ,  $V_{EE} = 0V$ ,  $T_A = -40^{\circ}C$  to  $85^{\circ}C$** 

Symbol	Parameter	Test Conditions	Minimum	Typical	Maximum	Units
$I_{IH}$	Input High Current	CLK, nCLK $V_{CC} = V_{IN} = 3.465V$			150	$\mu A$
$I_{IL}$	Input Low Current	CLK $V_{CC} = 3.465V$ , $V_{IN} = 0V$	-10			$\mu A$
		nCLK $V_{CC} = 3.465V$ , $V_{IN} = 0V$	-150			$\mu A$
$V_{PP}$	Peak-to-Peak Input Voltage	CLK, nCLK	0.15		1.3	V
$V_{CMR}$	Common Mode Input Voltage; NOTE 1	CLK, nCLK	$V_{EE} + 0.5$		$V_{CC} - 0.85$	V

NOTE 1. Common mode voltage is defined as  $V_{IH}$ .

**Table 4G. LVPECL DC Characteristics,  $V_{CC} = V_{CC\_TAP} = 3.3V \pm 5\%$ ,  $V_{EE} = 0V$ ,  $T_A = -40^{\circ}C$  to  $85^{\circ}C$** 

Symbol	Parameter	Test Conditions	Minimum	Typical	Maximum	Units
$I_{IH}$	Input High Current	PCLK, nPCLK $V_{CC} = V_{IN} = 3.465V$			150	$\mu A$
$I_{IL}$	Input Low Current	PCLK $V_{CC} = 3.465V, V_{IN} = 0V$	-10			$\mu A$
		nPCLK $V_{CC} = 3.465V, V_{IN} = 0V$	-150			$\mu A$
$V_{PP}$	Peak-to-Peak Input Voltage	PCLK, nPCLK	0.15		1.3	V
$V_{CMR}$	Common Mode Input Voltage; NOTE 1	PCLK, nPCLK	$V_{EE} + 1.2$		$V_{CC}$	V
$V_{OH}$	Output High Voltage; NOTE 2	SEL_OUT = 1	$V_{CC} - 1.4$		$V_{CC} - 0.9$	V
$V_{OL}$	Output Low Voltage; NOTE 2	SEL_OUT = 1	$V_{CC} - 2.0$		$V_{CC} - 1.7$	V
$V_{SWING}$	Peak-to-peak Output Voltage Swing	SEL_OUT = 1	0.6		1.0	V

NOTE 1: Common mode voltage is defined as  $V_{IH}$ .  
 NOTE 2: Outputs terminated with  $50\Omega$  to  $V_{CC} - 2V$ .

**Table 4H. LVPECL DC Characteristics,  $V_{CC} = V_{CC\_TAP} = 2.5V \pm 5\%$ ,  $V_{EE} = 0V$ ,  $T_A = -40^{\circ}C$  to  $85^{\circ}C$** 

Symbol	Parameter	Test Conditions	Minimum	Typical	Maximum	Units
$I_{IH}$	Input High Current	PCLK, nPCLK $V_{CC} = V_{IN} = 2.625V$			150	$\mu A$
$I_{IL}$	Input Low Current	PCLK $V_{CC} = 2.625V, V_{IN} = 0V$	-10			$\mu A$
		nPCLK $V_{CC} = 2.625V, V_{IN} = 0V$	-150			$\mu A$
$V_{PP}$	Peak-to-Peak Input Voltage	PCLK, nPCLK	0.15		1.3	V
$V_{CMR}$	Common Mode Input Voltage; NOTE 1	PCLK, nPCLK	$V_{EE} + 1.2$		$V_{CC}$	V
$V_{OH}$	Output High Voltage; NOTE 2	SEL_OUT = 1	$V_{CC} - 1.4$		$V_{CC} - 0.9$	V
$V_{OL}$	Output Low Voltage; NOTE 2	SEL_OUT = 1	$V_{CC} - 2.0$		$V_{CC} - 1.5$	V
$V_{SWING}$	Peak-to-peak Output Voltage Swing	SEL_OUT = 1	0.4		1.0	V

NOTE 1: Common mode voltage is defined as  $V_{IH}$ .  
 NOTE 2: Outputs terminated with  $50\Omega$  to  $V_{CC} - 2V$ .

**Table 4I. LVDS DC Characteristics,  $V_{CC} = 3.3V \pm 5\%$ ,  $T_A = -40^{\circ}C$  to  $85^{\circ}C$** 

Symbol	Parameter	Test Conditions	Minimum	Typical	Maximum	Units
$V_{OD}$	Differential Output Voltage	SEL_OUT = 0	247		454	mV
$\Delta V_{OD}$	$V_{OD}$ Magnitude Change	SEL_OUT = 0			50	mV
$V_{OS}$	Offset Voltage	SEL_OUT = 0	1.125		1.375	V
$\Delta V_{OS}$	$V_{OS}$ Magnitude Change	SEL_OUT = 0			50	mV

**Table 4J. LVDS DC Characteristics,  $V_{CC} = V_{CC\_TAP} = 2.5V \pm 5\%$ ,  $T_A = -40^{\circ}C$  to  $85^{\circ}C$** 

Symbol	Parameter	Test Conditions	Minimum	Typical	Maximum	Units
$V_{OD}$	Differential Output Voltage	SEL_OUT = 0	247		454	mV
$\Delta V_{OD}$	$V_{OD}$ Magnitude Change	SEL_OUT = 0			50	mV
$V_{OS}$	Offset Voltage	SEL_OUT = 0	1.105		1.375	V
$\Delta V_{OS}$	$V_{OS}$ Magnitude Change	SEL_OUT = 0			50	mV

## AC Electrical Characteristics

**Table 5A. LVPECL AC Characteristics,  $V_{CC} = V_{CC\_TAP} = 3.3V \pm 5\%$ ,  $V_{EE} = 0V$ ,  $T_A = -40^\circ C$  to  $85^\circ C$**

Symbol	Parameter	Test Conditions	Minimum	Typical	Maximum	Units
$f_{OUT}$	Output Frequency				2	GHz
$t_{PD}$	Propagation Delay, Low-to-High; NOTE 1		300		800	ps
$tsk(o)$	Output Skew; NOTE 2, 3				55	ps
$tsk(pp)$	Part-to-Part Skew; NOTE 3, 4				250	ps
$f_{jit}$	Buffer Additive Phase Jitter, RMS; refer to Additive Phase Jitter Section	156.25MHz, Integration Range: 12kHz - 5MHz		0.046	0.065	ps
		156.25MHz, Integration Range: 12kHz - 20MHz		0.083	0.120	ps
		245.76MHz, Integration Range: 12kHz - 5MHz		0.034	0.059	ps
		245.76MHz, Integration Range: 12kHz - 20MHz		0.068	0.094	ps
$t_R / t_F$	Output Rise/Fall Time	20% to 80%	80		220	ps
odc	Output Duty Cycle		45		55	%
$MUX_{ISOLATION}$	MUX Isolation	@ 100MHz		85		dB

All parameters measured at  $f_{OUT} \leq 1GHz$  unless noted otherwise.

NOTE: Electrical parameters are guaranteed over the specified ambient operating temperature range, which is established when the device is mounted in a test socket with maintained transverse airflow greater than 500 lpm. The device will meet specifications after thermal equilibrium has been reached under these conditions.

NOTE 1: Measured from the differential input crossing point to the differential output crossing point.

NOTE 2: Defined as skew between outputs at the same supply voltage and with equal load conditions.

Measured from the output differential cross points.

NOTE 3: This parameter is defined in accordance with JEDEC Standard 65.

NOTE 4: Defined as skew between outputs on different devices operating at the same supply voltage, same temperature, same frequency and with equal load conditions. Using the same type of inputs on each device, the outputs are measured at the differential cross points.

**Table 5B. LVPECL AC Characteristics,  $V_{CC} = V_{CC\_TAP} = 2.5V \pm 5\%$ ,  $V_{EE} = 0V$ ,  $T_A = -40^\circ C$  to  $85^\circ C$**

Symbol	Parameter	Test Conditions	Minimum	Typical	Maximum	Units
$f_{OUT}$	Output Frequency				2	GHz
$t_{PD}$	Propagation Delay, Low-to-High; NOTE 1		300		800	ps
$tsk(o)$	Output Skew; NOTE 2, 3				55	ps
$tsk(pp)$	Part-to-Part Skew; NOTE 3, 4				250	ps
$f_{jit}$	Buffer Additive Phase Jitter, RMS; refer to Additive Phase Jitter Section	156.25MHz, Integration Range: 12kHz - 5MHz		0.054	0.079	ps
		156.25MHz, Integration Range: 12kHz - 20MHz		0.097	0.134	ps
		245.76MHz, Integration Range: 12kHz - 5MHz		0.050	0.067	ps
		245.76MHz, Integration Range: 12kHz - 20MHz		0.099	0.131	ps
$t_R / t_F$	Output Rise/Fall Time	20% to 80%	80		210	ps
odc	Output Duty Cycle		45		55	%
$MUX_{ISOLATION}$	MUX Isolation	@ 100MHz		85		dB

For NOTES, see Table 5A above.

**Table 5C. LVDS AC Characteristics,  $V_{CC} = 3.3V \pm 5\%$ ,  $V_{EE} = 0V$ ,  $T_A = -40^\circ C$  to  $85^\circ C$** 

Symbol	Parameter	Test Conditions	Minimum	Typical	Maximum	Units
$f_{OUT}$	Output Frequency				2	GHz
$t_{PD}$	Propagation Delay, Low-to-High; NOTE 1		300		800	ps
$tsk(o)$	Output Skew; NOTE 2, 3				55	ps
$tsk(pp)$	Part-to-Part Skew; NOTE 3, 4				250	ps
$f_{jit}$	Buffer Additive Phase Jitter, RMS; refer to Additive Phase Jitter Section	156.25MHz, Integration Range: 12kHz - 5MHz		0.048	0.074	ps
		156.25MHz, Integration Range: 12kHz - 20MHz		0.096	0.146	ps
		245.76MHz, Integration Range: 12kHz - 5MHz		0.035	0.054	ps
		245.76MHz, Integration Range: 12kHz - 20MHz		0.074	0.097	ps
$t_R / t_F$	Output Rise/Fall Time	20% to 80%	80		200	ps
odc	Output Duty Cycle		45		55	%
$MUX_{ISOLATION}$	MUX Isolation	@ 100MHz		85		dB

All parameters measured at  $f_{OUT} \leq 1GHz$  unless noted otherwise.

NOTE: Electrical parameters are guaranteed over the specified ambient operating temperature range, which is established when the device is mounted in a test socket with maintained transverse airflow greater than 500 lpm. The device will meet specifications after thermal equilibrium has been reached under these conditions.

NOTE 1: Measured from the differential input crossing point to the differential output crossing point.

NOTE 2: Defined as skew between outputs at the same supply voltage and with equal load conditions.

Measured from the output differential cross points.

NOTE 3: This parameter is defined in accordance with JEDEC Standard 65.

NOTE 4: Defined as skew between outputs on different devices operating at the same supply voltage, same temperature, same frequency and with equal load conditions. Using the same type of inputs on each device, the outputs are measured at the differential cross points.

**Table 5D. LVDS AC Characteristics,  $V_{CC} = V_{CC\_TAP} = 2.5V \pm 5\%$ ,  $V_{EE} = 0V$ ,  $T_A = -40^\circ C$  to  $85^\circ C$** 

Symbol	Parameter	Test Conditions	Minimum	Typical	Maximum	Units
$f_{OUT}$	Output Frequency				2	GHz
$t_{PD}$	Propagation Delay, Low-to-High; NOTE 1		300		800	ps
$tsk(o)$	Output Skew; NOTE 2, 3				55	ps
$tsk(pp)$	Part-to-Part Skew; NOTE 3, 4				250	ps
$f_{jit}$	Buffer Additive Phase Jitter, RMS; refer to Additive Phase Jitter Section	156.25MHz, Integration Range: 12kHz - 5MHz		0.049	0.074	ps
		156.25MHz, Integration Range: 12kHz - 20MHz		0.098	0.139	ps
		245.76MHz, Integration Range: 12kHz - 5MHz		0.037	0.060	ps
		245.76MHz, Integration Range: 12kHz - 20MHz		0.076	0.102	ps
$t_R / t_F$	Output Rise/Fall Time	20% to 80%	80		200	ps
odc	Output Duty Cycle		45		55	%
$MUX_{ISOLATION}$	MUX Isolation	@ 100MHz		85		dB

For NOTES, see Table 5C above.

## Additive Phase Jitter

The spectral purity in a band at a specific offset from the fundamental compared to the power of the fundamental is called the **dBc Phase Noise**. This value is normally expressed using a Phase noise plot and is most often the specified plot in many applications. Phase noise is defined as the ratio of the noise power present in a 1Hz band at a specified offset from the fundamental frequency to the power value of the fundamental. This ratio is expressed in decibels (dBm) or a ratio

of the power in the 1Hz band to the power in the fundamental. When the required offset is specified, the phase noise is called a **dBc** value, which simply means dBm at a specified offset from the fundamental. By investigating jitter in the frequency domain, we get a better understanding of its effects on the desired application over the entire time record of the signal. It is mathematically possible to calculate an expected bit error rate given a phase noise plot.

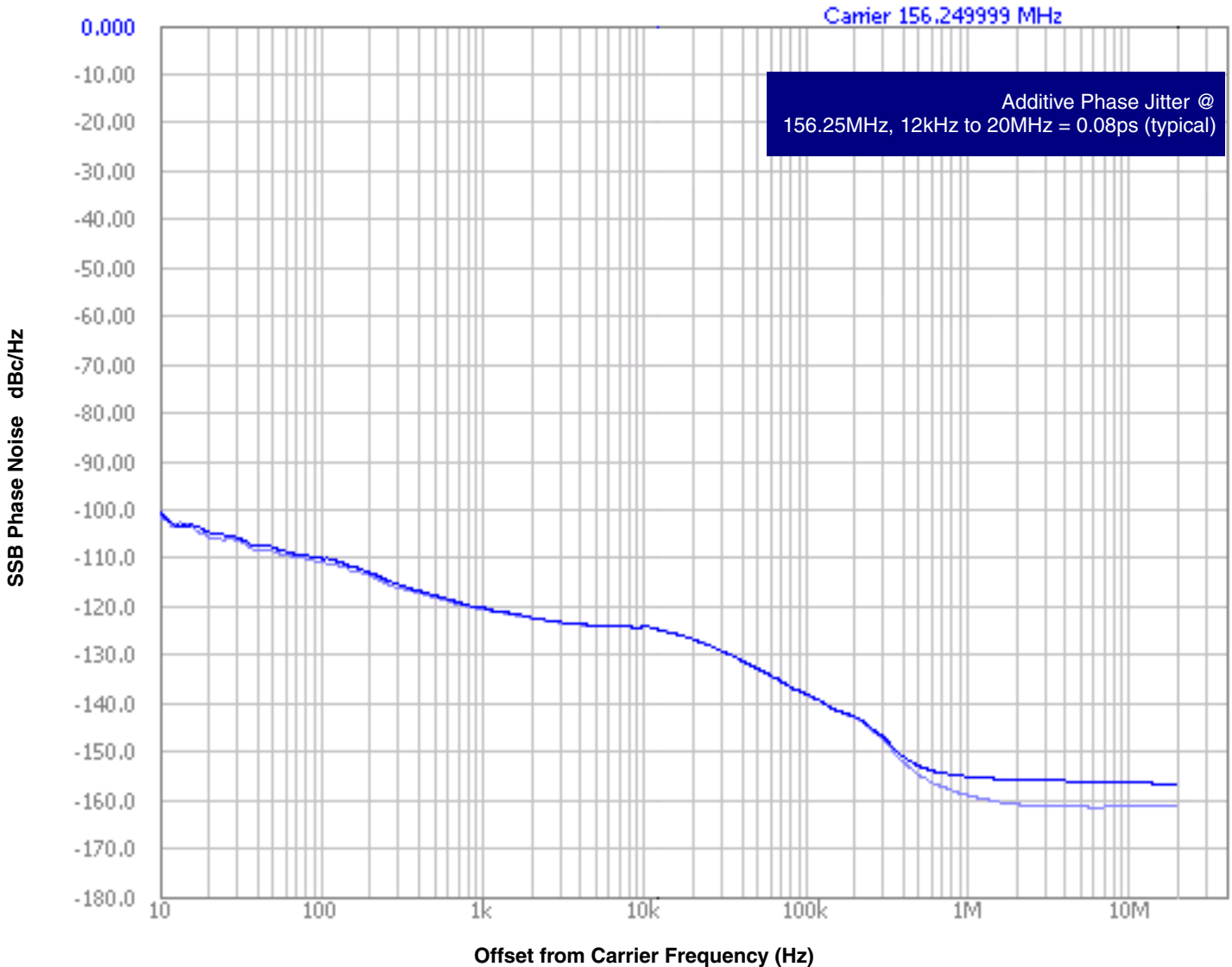

As with most timing specifications, phase noise measurements has issues relating to the limitations of the equipment. Often the noise floor of the equipment is higher than the noise floor of the device. This is illustrated above. The device meets the noise floor of what is shown, but can actually be lower. The phase noise is dependent on the input source and measurement equipment.

The source generator used is, "Rhode & Schwarz SMA 100A Signal Generator, via the clock synthesis as the external input to drive the input clock."

## Parameter Measurement Information

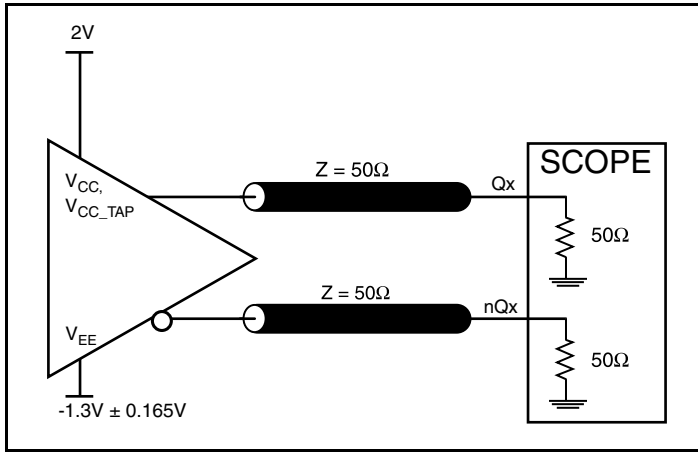

3.3V LVPECL Output Load AC Test Circuit

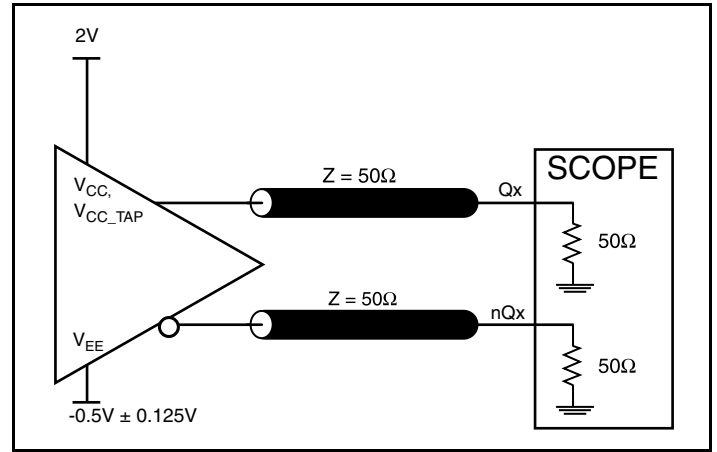

2.5V LVPECL Output Load AC Test Circuit

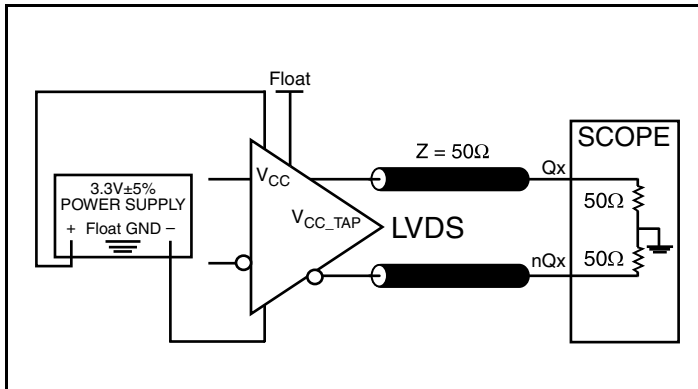

3.3V LVDS Output Load AC Test Circuit

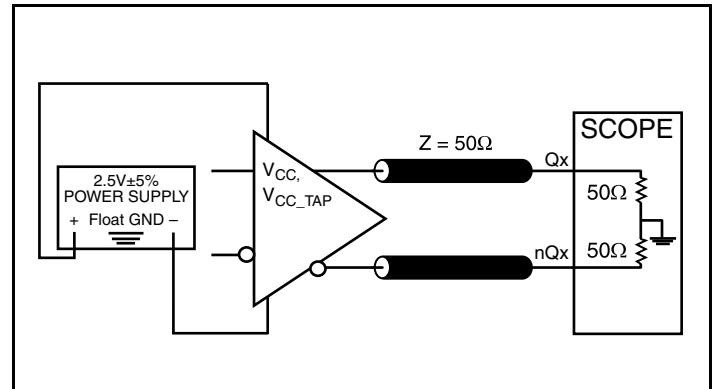

2.5V LVDS Output Load AC Test Circuit

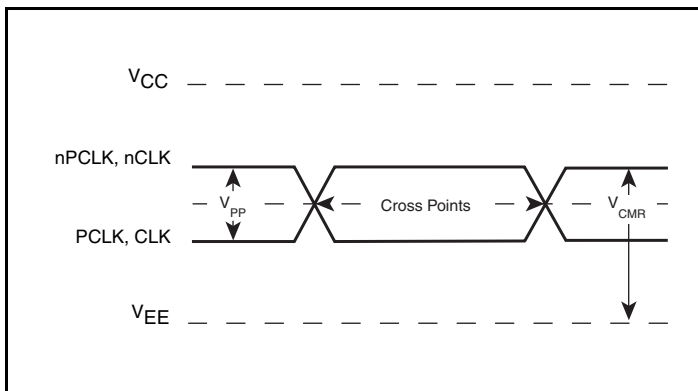

Differential Input Level

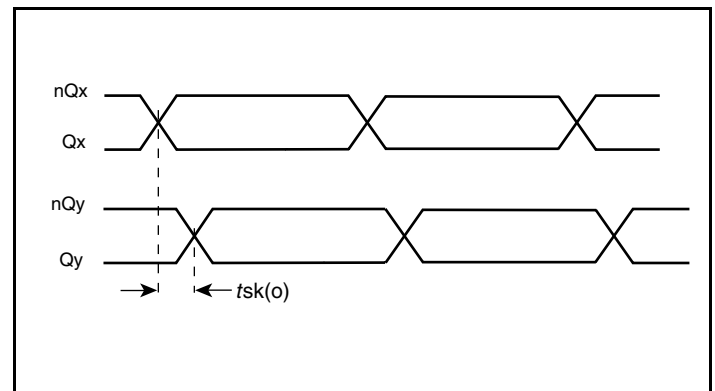

Output Skew

Parameter Measurement Information, continued

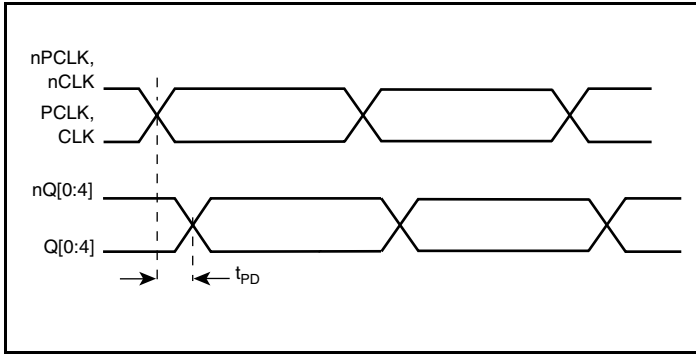

Propagation Delay

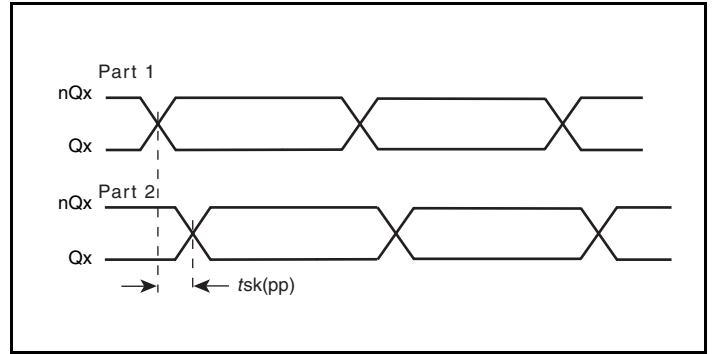

Part-to-Part Skew

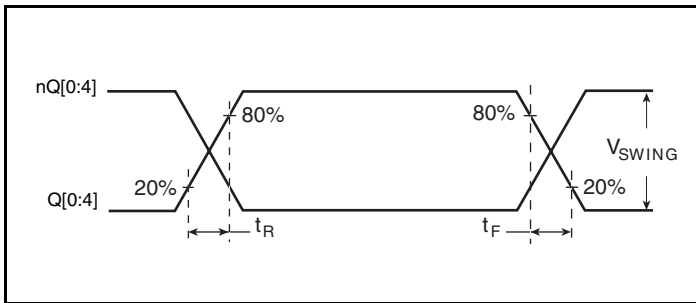

LVPECL Output Rise/Fall Time

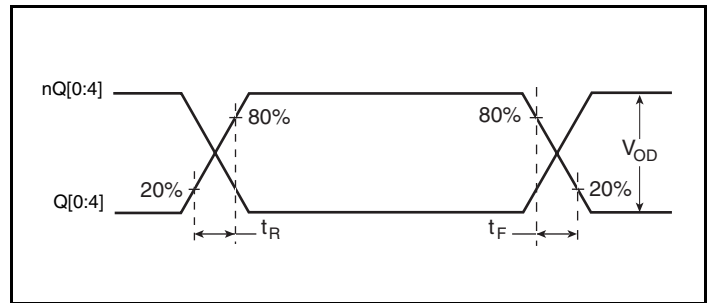

LVDS Output Rise/Fall Time

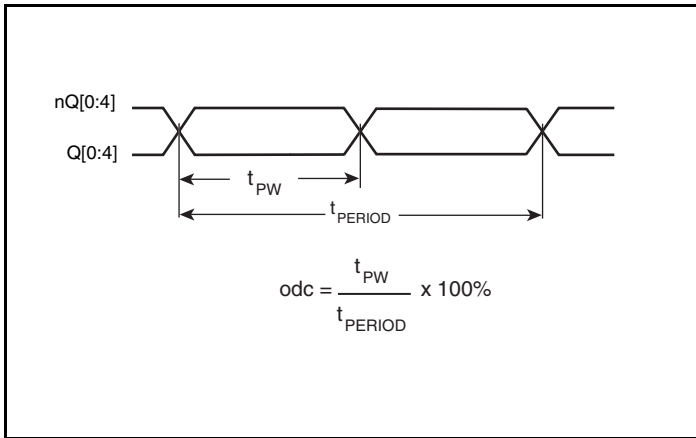

Output Duty Cycle/Pulse Width/Period

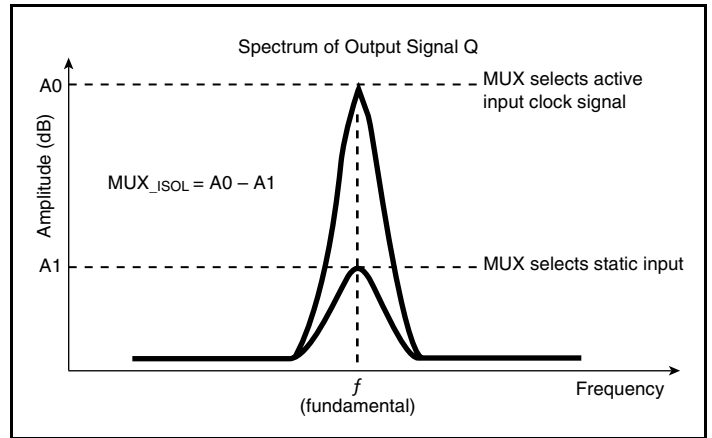

MUX Isolation

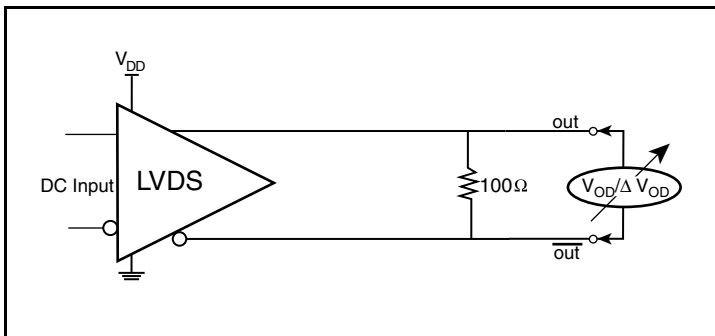

Differential Output Voltage Setup

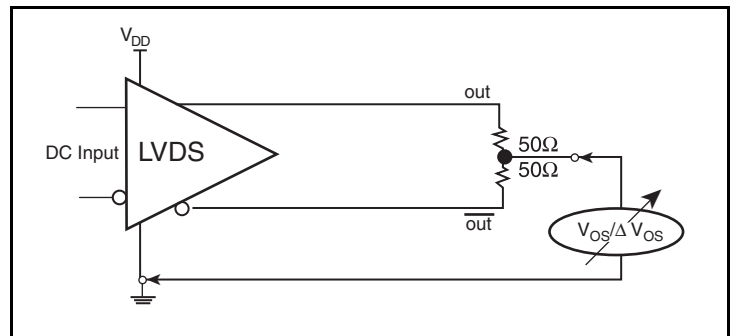

Offset Voltage Setup

## Applications Information

### Recommendations for Unused Input and Output Pins

#### Inputs:

##### PCLK/nPCLK Inputs

For applications not requiring the use of a differential input, both the PCLK and nPCLK pins can be left floating. Though not required, but for additional protection, a 1kΩ resistor can be tied from PCLK to ground.

##### CLK/nCLK Inputs

For applications not requiring the use of a differential input, both the CLK and nCLK pins can be left floating. Though not required, but for additional protection, a 1kΩ resistor can be tied from CLK to ground.

##### LVCMOS Control Pins

All control pins have internal pulldowns; additional resistance is not required but can be added for additional protection. A 1kΩ resistor can be used.

#### Outputs:

##### LVPECL Outputs

All unused LVPECL outputs can be left floating. We recommend that there is no trace attached. Both sides of the differential output pair should either be left floating or terminated.

##### LVDS Outputs

All unused LVDS output pairs can be either left floating or terminated with 100Ω across. If they are left floating, there should be no trace attached.

### Wiring the Differential Input to Accept Single-Ended Levels

Figure 2 shows how a differential input can be wired to accept single ended levels. The reference voltage  $V_{REF} = V_{CC}/2$  is generated by the bias resistors R1 and R2. The bypass capacitor (C1) is used to help filter noise on the DC bias. This bias circuit should be located as close to the input pin as possible. The ratio of R1 and R2 might need to be adjusted to position the  $V_{REF}$  in the center of the input voltage swing. For example, if the input clock swing is 2.5V and  $V_{CC} = 3.3V$ , R1 and R2 value should be adjusted to set  $V_{REF}$  at 1.25V. The values below are for when both the single ended swing and  $V_{CC}$  are at the same voltage. This configuration requires that the sum of the output impedance of the driver ( $R_o$ ) and the series resistance ( $R_s$ ) equals the transmission line impedance. In addition, matched termination at the input will attenuate the signal in half. This can be done in one of two ways. First, R3 and R4 in parallel should equal the transmission

line impedance. For most 50Ω applications, R3 and R4 can be 100Ω. The values of the resistors can be increased to reduce the loading for slower and weaker LVCMOS driver. When using single-ended signaling, the noise rejection benefits of differential signaling are reduced. Even though the differential input can handle full rail LVCMOS signaling, it is recommended that the amplitude be reduced. The datasheet specifies a lower differential amplitude, however this only applies to differential signals. For single-ended applications, the swing can be larger, however  $V_{IL}$  cannot be less than -0.3V and  $V_{IH}$  cannot be more than  $V_{CC} + 0.3V$ . Though some of the recommended components might not be used, the pads should be placed in the layout. They can be utilized for debugging purposes. The datasheet specifications are characterized and guaranteed by using a differential signal.

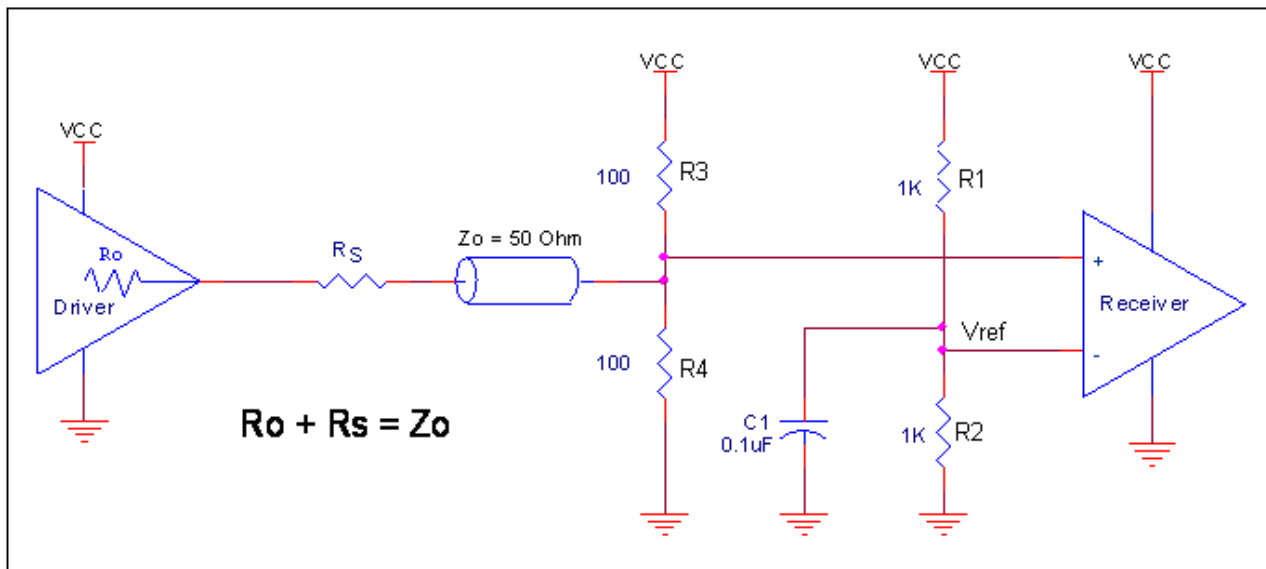
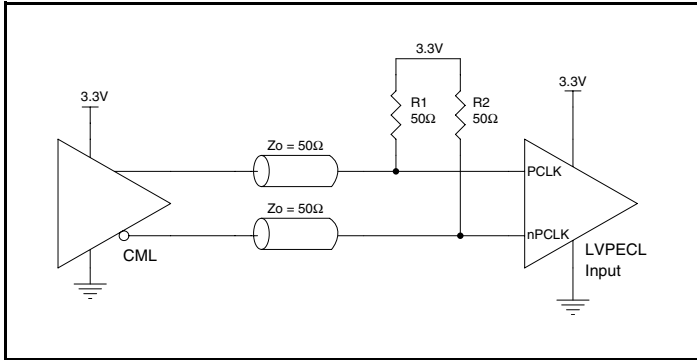

Figure 2. Recommended Schematic for Wiring a Differential Input to Accept Single-ended Levels

### 3.3V LVPECL Clock Input Interface

The PCLK/nPCLK accepts LVPECL, CML, LVDS and other differential signals. Both  $V_{SWING}$  and  $V_{OH}$  must meet the  $V_{PP}$  and  $V_{CMR}$  input requirements. Figures 3A to 3E show interface examples for the PCLK/nPCLK input driven by the most common driver types.

The input interfaces suggested here are examples only. If the driver is from another vendor, use their termination recommendation. Please consult with the vendor of the driver component to confirm the driver termination requirements.



**Figure 3A. PCLK/nPCLK Input Driven by an Open Collector CML Driver**

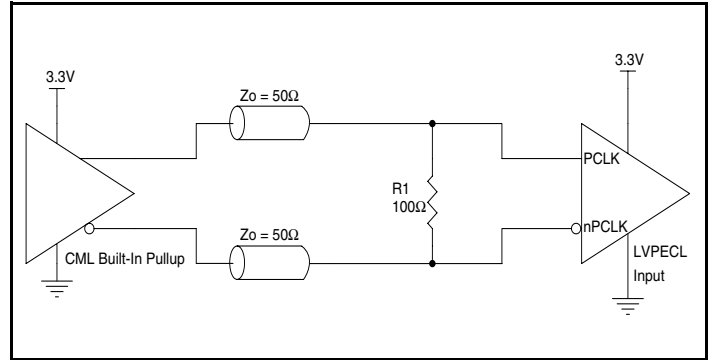

**Figure 3B. PCLK/nPCLK Input Driven by a Built-In Pullup CML Driver**

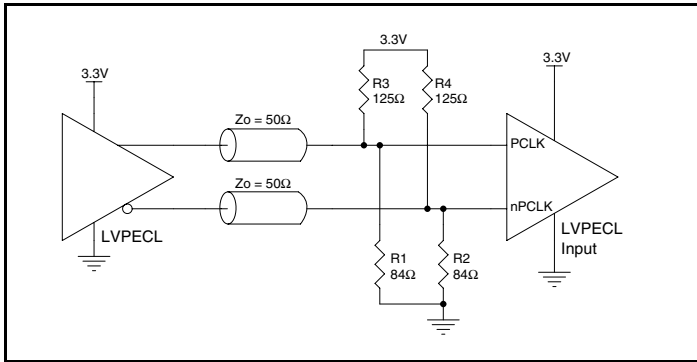

**Figure 3C. PCLK/nPCLK Input Driven by a 3.3V LVPECL Driver**

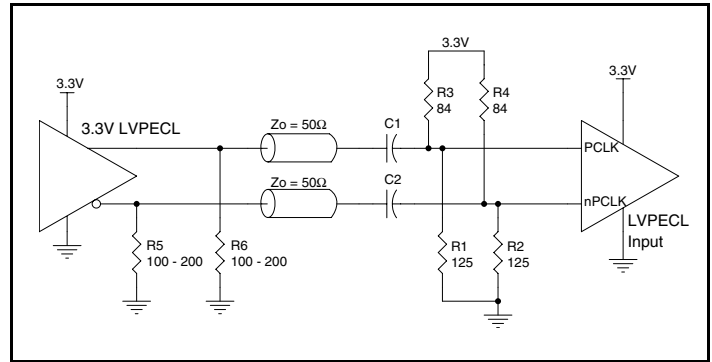

**Figure 3D. PCLK/nPCLK Input Driven by a 3.3V LVPECL Driver with AC Couple**

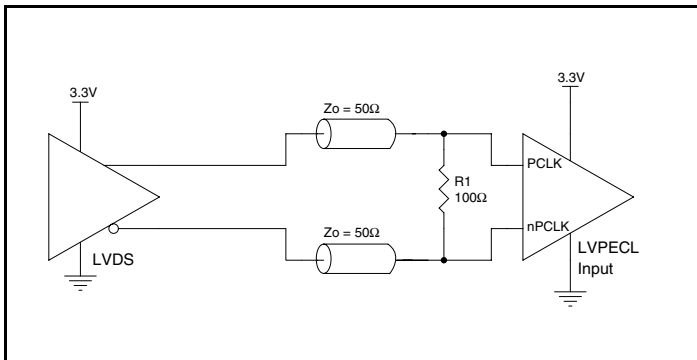

**Figure 3E. PCLK/nPCLK Input Driven by an LVDS Driver**

## 2.5V LVPECL Clock Input Interface

The PCLK /nPCLK accepts LVPECL, CML, LVDS and other differential signals. Both  $V_{SWING}$  and  $V_{OH}$  must meet the  $V_{PP}$  and  $V_{CMR}$  input requirements. Figures 4A to 4E show interface examples for the PCLK/nPCLK input driven by the most common driver types.

The input interfaces suggested here are examples only. If the driver is from another vendor, use their termination recommendation. Please consult with the vendor of the driver component to confirm the driver termination requirements.

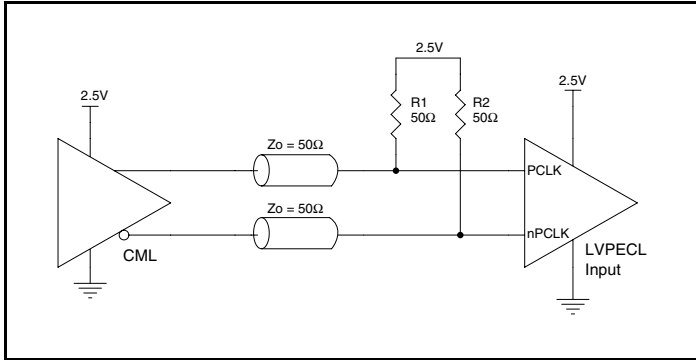

Figure 4A. PCLK/nPCLK Input Driven by an Open Collector CML Driver

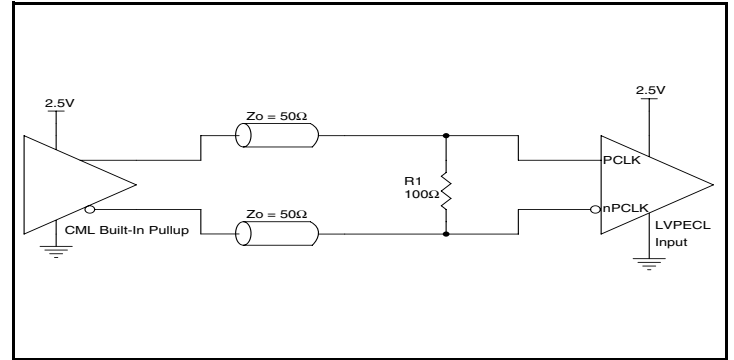

Figure 4B. PCLK/nPCLK Input Driven by a Built-In Pullup CML Driver

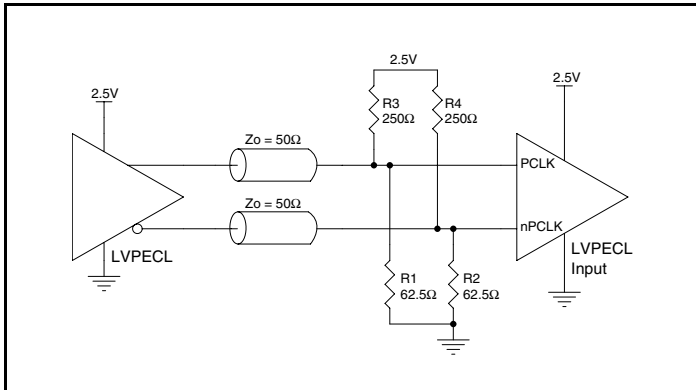

Figure 4C. PCLK/nPCLK Input Driven by a 3.3V LVPECL Driver

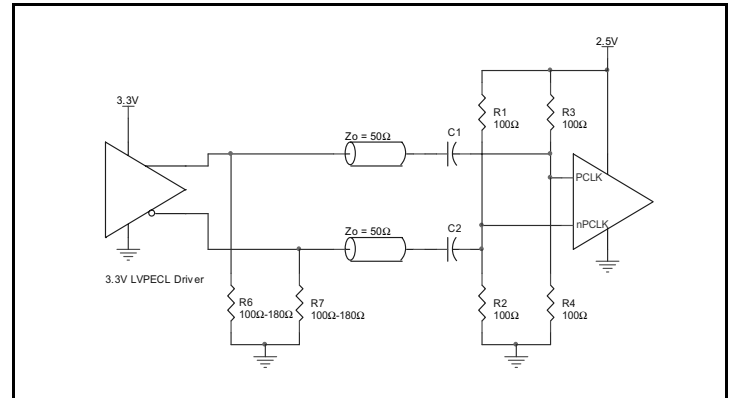

Figure 4D. PCLK/nPCLK Input Driven by a 3.3V LVPECL Driver with AC Couple

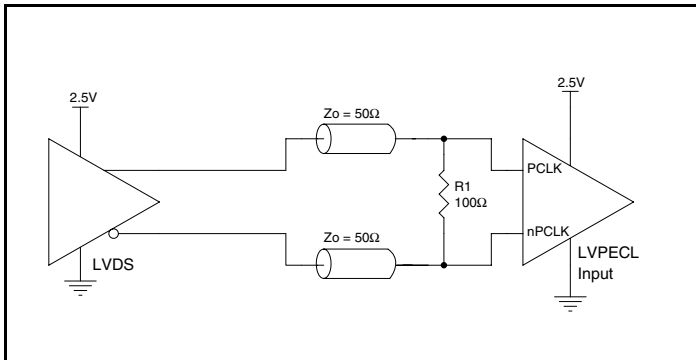
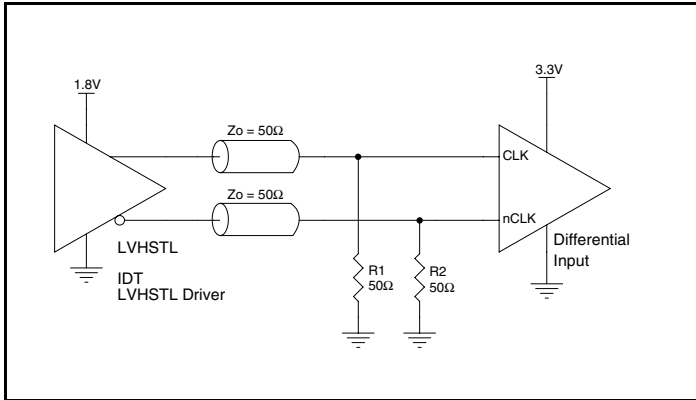

Figure 4E. PCLK/nPCLK Input Driven by a LVDS Driver

### 3.3V Differential Clock Input Interface

The CLK /nCLK accepts LVDS, LVPECL, LVHSTL, HCSL and other differential signals. Both  $V_{SWING}$  and  $V_{OH}$  must meet the  $V_{PP}$  and  $V_{CMR}$  input requirements. *Figures 5A to 5E* show interface examples for the CLK/nCLK input driven by the most common driver types. The input interfaces suggested here are examples only. Please consult

with the vendor of the driver component to confirm the driver termination requirements. For example, in Figure 5A, the input termination applies for IDT open emitter LVHSTL drivers. If you are using an LVHSTL driver from another vendor, use their termination recommendation.



**Figure 5A. CLK/nCLK Input Driven by an IDT Open Emitter LVHSTL Driver**

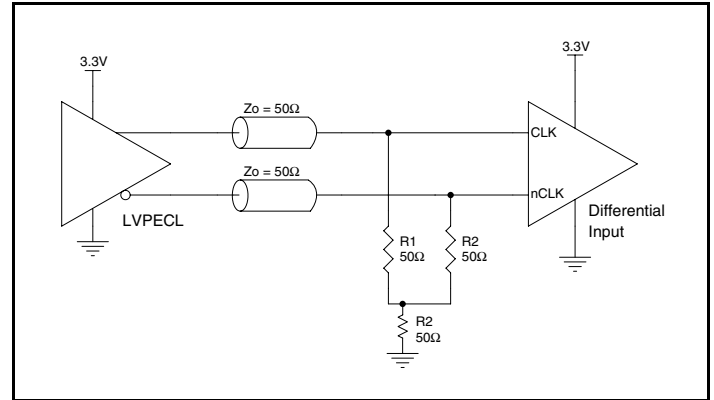

**Figure 5B. CLK/nCLK Input Driven by a 3.3V LVPECL Driver**

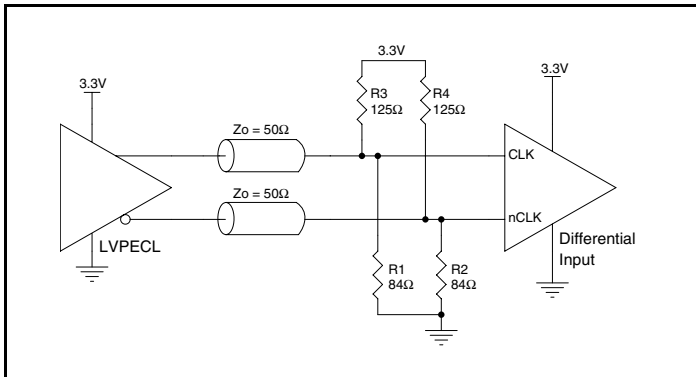

**Figure 5C. CLK/nCLK Input Driven by a 3.3V LVPECL Driver**

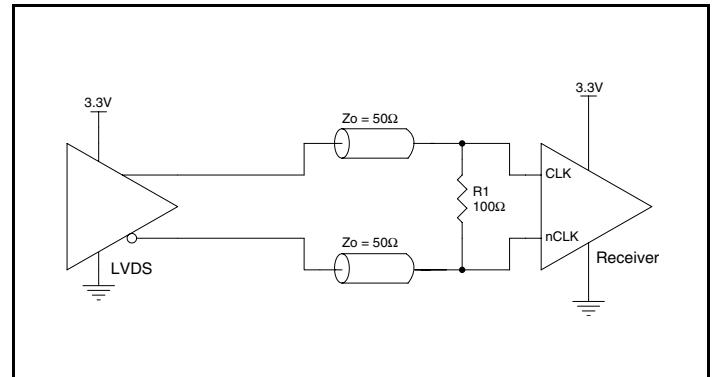

**Figure 5D. CLK/nCLK Input Driven by a 3.3V LVDS Driver**

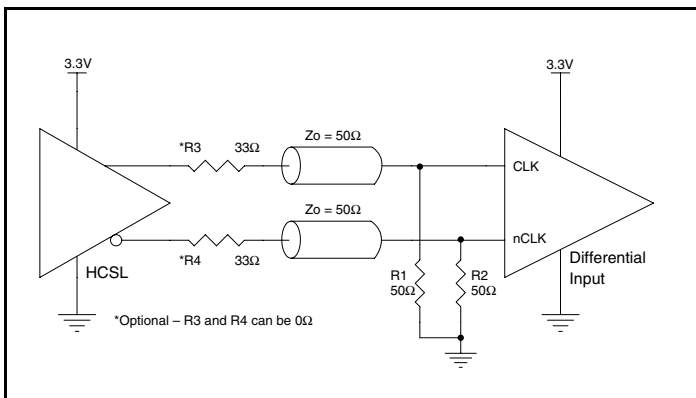
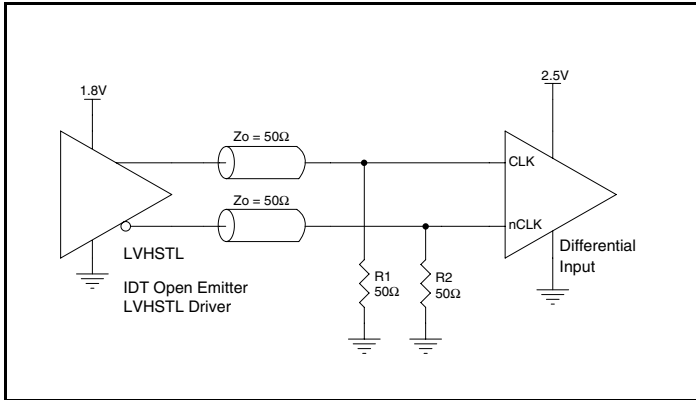

**Figure 5E. CLK/nCLK Input Driven by a 3.3V HCSL Driver**

## 2.5V Differential Clock Input Interface

The CLK /nCLK accepts LVDS, LVPECL, LVHSTL, HCSL and other differential signals. Both  $V_{SWING}$  and  $V_{OH}$  must meet the  $V_{PP}$  and  $V_{CMR}$  input requirements. *Figures 6A to 6E* show interface examples for the CLK/nCLK input driven by the most common driver types. The input interfaces suggested here are examples only. Please consult

with the vendor of the driver component to confirm the driver termination requirements. For example, in Figure 6A, the input termination applies for IDT open emitter LVHSTL drivers. If you are using an LVHSTL driver from another vendor, use their termination recommendation.



**Figure 6A.** CLK/nCLK Input Driven by an IDT Open Emitter LVHSTL Driver

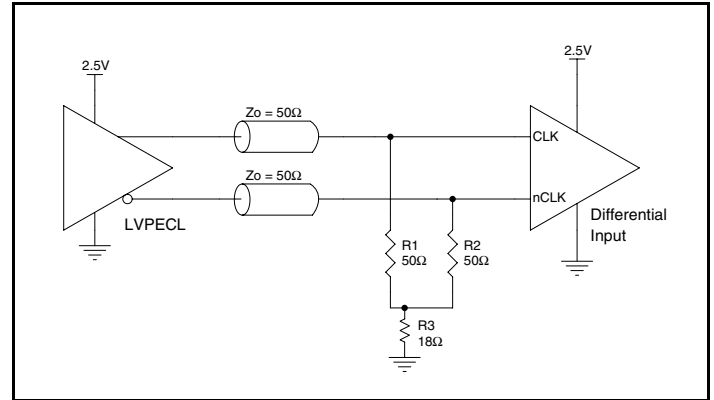

**Figure 6B.** CLK/nCLK Input Driven by a 2.5V LVPECL Driver

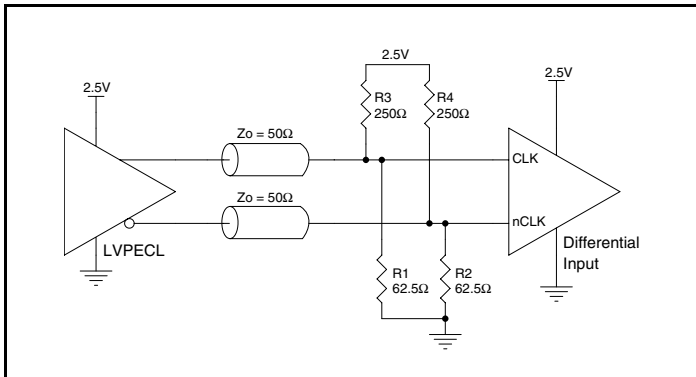

**Figure 6C.** CLK/nCLK Input Driven by a 2.5V LVPECL Driver

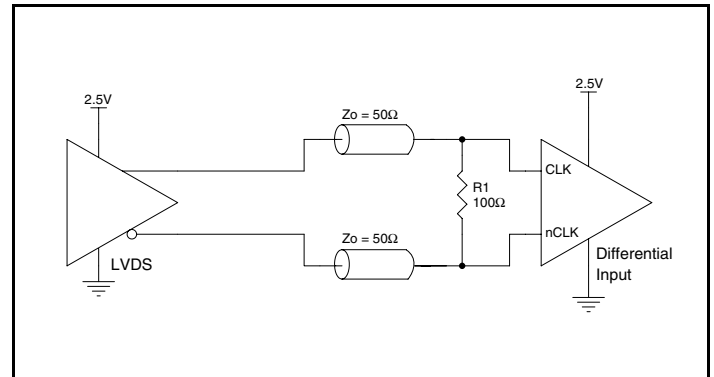

**Figure 6D.** CLK/nCLK Input Driven by a 2.5V LVDS Driver

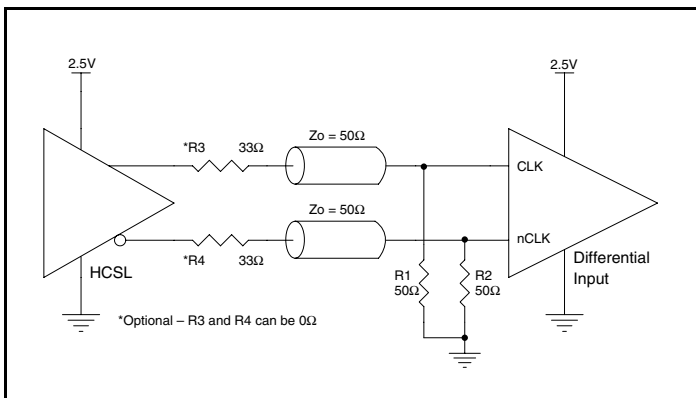
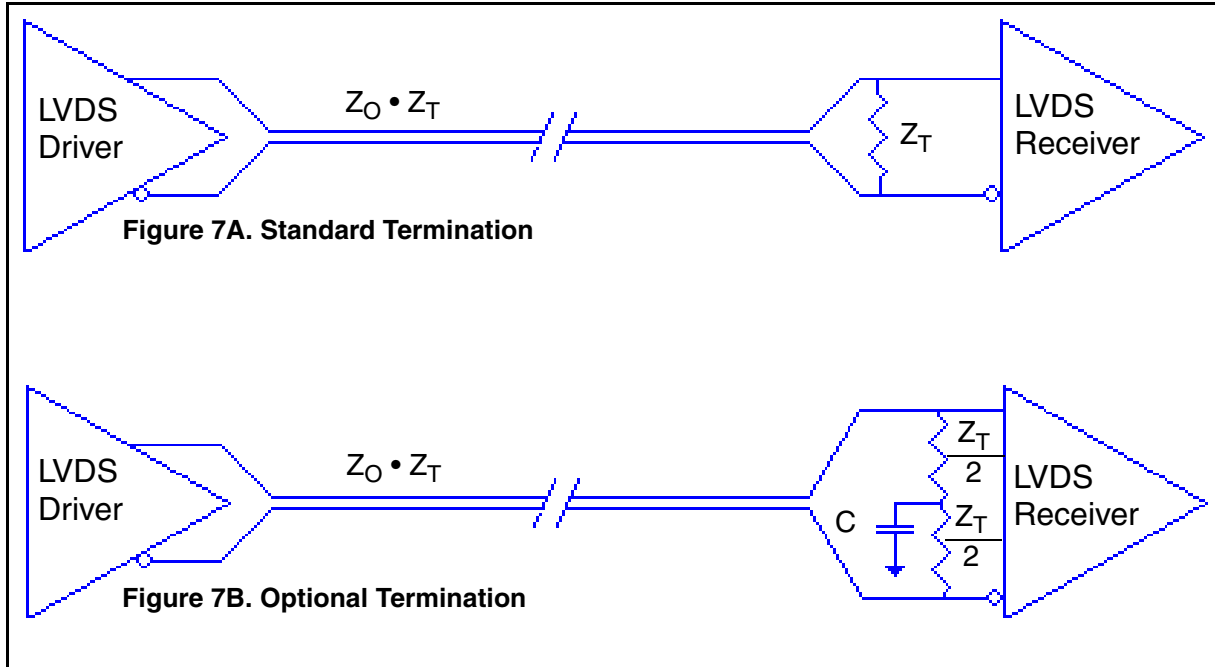

**Figure 6E.** CLK/nCLK Input Driven by a 2.5V HCSL Driver

## LVDS Driver Termination

For a general LVDS interface, the recommended value for the termination impedance ( $Z_T$ ) is between  $90\Omega$  and  $132\Omega$ . The actual value should be selected to match the differential impedance ( $Z_0$ ) of your transmission line. A typical point-to-point LVDS design uses a  $100\Omega$  parallel resistor at the receiver and a  $100\Omega$  differential transmission-line environment. In order to avoid any transmission-line reflection issues, the components should be surface mounted and must be placed as close to the receiver as possible. IDT offers a full line of LVDS compliant devices with two types of output structures: current source and voltage source type. The

standard termination schematic as shown in *Figure 7A* can be used with either type of output structure. *Figure 7B*, which can also be used with both output types, is an optional termination with center tap capacitance to help filter common mode noise. The capacitor value should be approximately  $50\text{pF}$ . If using a non-standard termination, it is recommended to contact IDT and confirm if the output structure is current source or voltage source type. In addition, since these outputs are LVDS compatible, the input receiver's amplitude and common-mode input range should be verified for compatibility with the output.



LVDS Termination

### Termination for 3.3V LVPECL Outputs

The clock layout topology shown below is a typical termination for LVPECL outputs. The two different layouts mentioned are recommended only as guidelines.

The differential outputs are low impedance follower outputs that generate ECL/LVPECL compatible outputs. Therefore, terminating resistors (DC current path to ground) or current sources must be used for functionality. These outputs are designed to drive 50Ω

transmission lines. Matched impedance techniques should be used to maximize operating frequency and minimize signal distortion.

Figures 8A and 8B show two different layouts which are recommended only as guidelines. Other suitable clock layouts may exist and it would be recommended that the board designers simulate to guarantee compatibility across all printed circuit and clock component process variations.

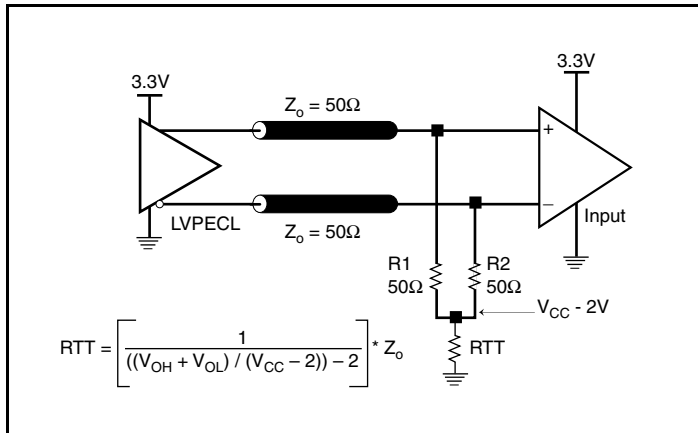

Figure 8A. 3.3V LVPECL Output Termination

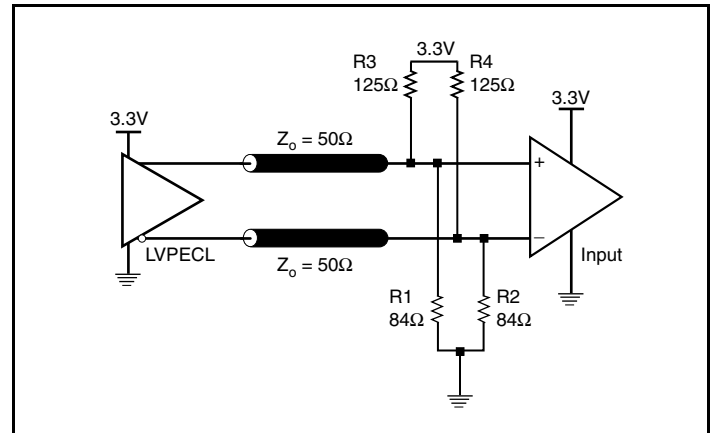

Figure 8B. 3.3V LVPECL Output Termination

## Termination for 2.5V LVPECL Outputs

Figure 9A and Figure 9B show examples of termination for 2.5V LVPECL driver. These terminations are equivalent to terminating  $50\Omega$  to  $V_{CC} - 2V$ . For  $V_{CC} = 2.5V$ , the  $V_{CC} - 2V$  is very close to ground

level. The R3 in Figure 9B can be eliminated and the termination is shown in Figure 9C.

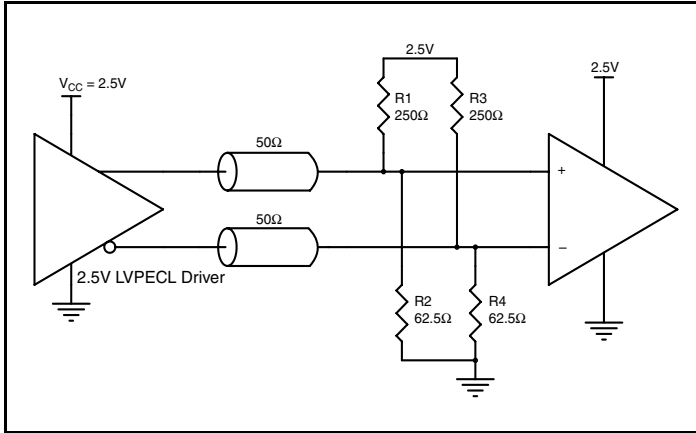

Figure 9A. 2.5V LVPECL Driver Termination Example

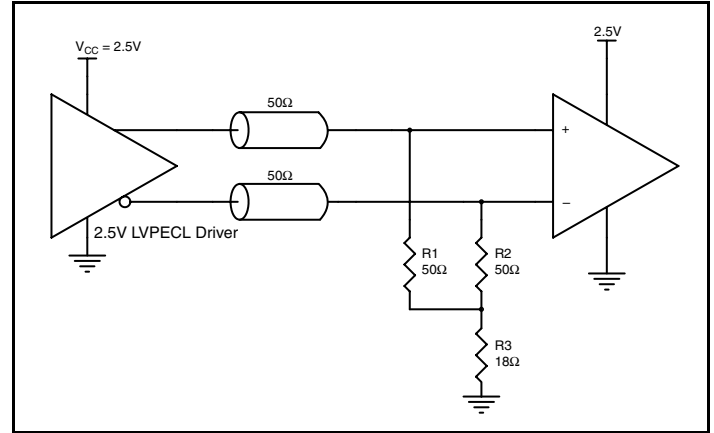

Figure 9B. 2.5V LVPECL Driver Termination Example

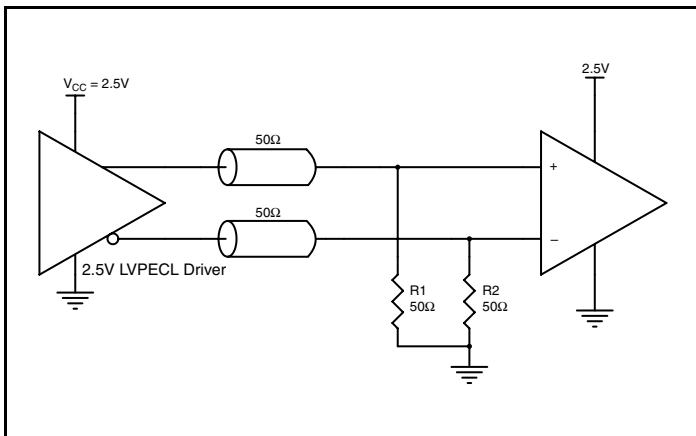

Figure 9C. 2.5V LVPECL Driver Termination Example

## VFQFN EPAD Thermal Release Path

In order to maximize both the removal of heat from the package and the electrical performance, a land pattern must be incorporated on the Printed Circuit Board (PCB) within the footprint of the package corresponding to the exposed metal pad or exposed heat slug on the package, as shown in *Figure 10*. The solderable area on the PCB, as defined by the solder mask, should be at least the same size/shape as the exposed pad/slug area on the package to maximize the thermal/electrical performance. Sufficient clearance should be designed on the PCB between the outer edges of the land pattern and the inner edges of pad pattern for the leads to avoid any shorts.

While the land pattern on the PCB provides a means of heat transfer and electrical grounding from the package to the board through a solder joint, thermal vias are necessary to effectively conduct from the surface of the PCB to the ground plane(s). The land pattern must be connected to ground through these vias. The vias act as “heat pipes”. The number of vias (i.e. “heat pipes”) are application specific

and dependent upon the package power dissipation as well as electrical conductivity requirements. Thus, thermal and electrical analysis and/or testing are recommended to determine the minimum number needed. Maximum thermal and electrical performance is achieved when an array of vias is incorporated in the land pattern. It is recommended to use as many vias connected to ground as possible. It is also recommended that the via diameter should be 12 to 13mils (0.30 to 0.33mm) with 1oz copper via barrel plating. This is desirable to avoid any solder wicking inside the via during the soldering process which may result in voids in solder between the exposed pad/slug and the thermal land. Precautions should be taken to eliminate any solder voids between the exposed heat slug and the land pattern. Note: These recommendations are to be used as a guideline only. For further information, please refer to the Application Note on the Surface Mount Assembly of Amkor’s Thermally/Electrically Enhance Leadframe Base Package, Amkor Technology.

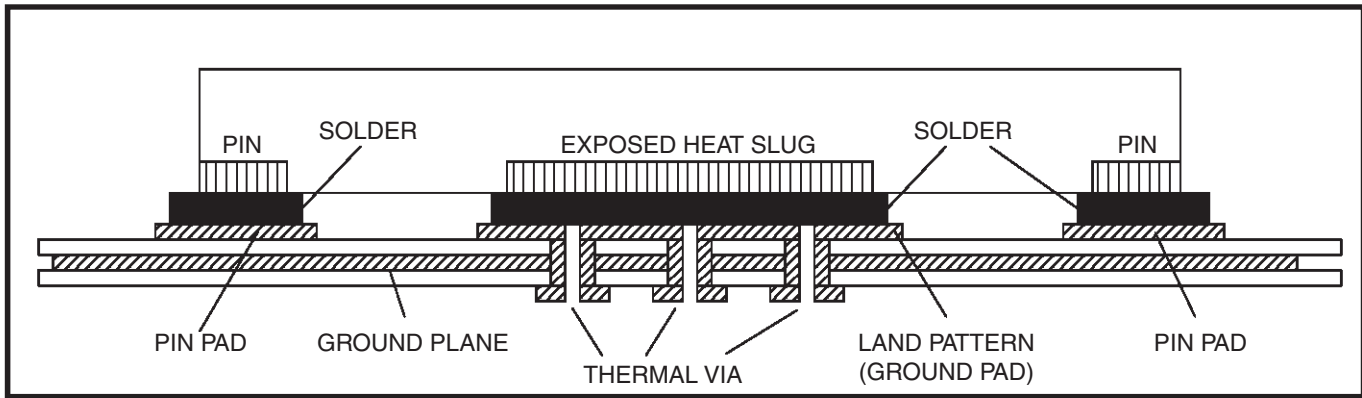

**Figure 10. P.C. Assembly for Exposed Pad Thermal Release Path – Side View (drawing not to scale)**

## LVPECL Power Considerations

This section provides information on power dissipation and junction temperature for the ICS854S015I-01. Equations and example calculations are also provided.

### 1. Power Dissipation.

The total power dissipation for the ICS854S015I-01 is the sum of the core power plus the power dissipated in the load(s). The following is the power dissipation for  $V_{CC} = 3.3V + 5\% = 3.465V$ , which gives worst case results.

NOTE: Please refer to Section 3 for details on calculating power dissipated in the load.

- Power (core)<sub>MAX</sub> =  $V_{CC\_MAX} * I_{EE\_MAX} = 3.465V * 85mA = \mathbf{294.53mW}$
- Power (outputs)<sub>MAX</sub> = **30mW/Loaded Output pair**  
If all outputs are loaded, the total power is  $5 * 30mW = \mathbf{150mW}$

**Total Power**<sub>MAX</sub> (3.3V, with all outputs switching) =  $294.53mW + 150mW = \mathbf{444.55mW}$

### 2. Junction Temperature.

Junction temperature,  $T_j$ , is the temperature at the junction of the bond wire and bond pad directly affects the reliability of the device. The maximum recommended junction temperature is 125°C. Limiting the internal transistor junction temperature,  $T_j$ , to 125°C ensures that the bond wire and bond pad temperature remains below 125°C.

The equation for  $T_j$  is as follows:  $T_j = \theta_{JA} * Pd\_total + T_A$

$T_j$  = Junction Temperature

$\theta_{JA}$  = Junction-to-Ambient Thermal Resistance

$Pd\_total$  = Total Device Power Dissipation (example calculation is in section 1 above)

$T_A$  = Ambient Temperature

In order to calculate junction temperature, the appropriate junction-to-ambient thermal resistance  $\theta_{JA}$  must be used. Assuming no air flow and a multi-layer board, the appropriate value is 49.5°C/W per Table 6 below.

Therefore,  $T_j$  for an ambient temperature of 85°C with all outputs switching is:

$$85^\circ\text{C} + 0.445\text{W} * 49.5^\circ\text{C/W} = 107^\circ\text{C}. \text{ This is below the limit of } 125^\circ\text{C}.$$

This calculation is only an example.  $T_j$  will obviously vary depending on the number of loaded outputs, supply voltage, air flow and the type of board (multi-layer).

**Table 6. Thermal Resistance  $\theta_{JA}$  for 24 Lead VFQFN, Forced Convection**

$\theta_{JA}$ by Velocity			
Meters per Second	0	1	2.5
Multi-Layer PCB, JEDEC Standard Test Boards	49.5°C/W	43.3°C/W	38.8°C/W

### 3. Calculations and Equations.

The purpose of this section is to calculate the power dissipation for the LVPECL output pair.

LVPECL output driver circuit and termination are shown in *Figure 11*.

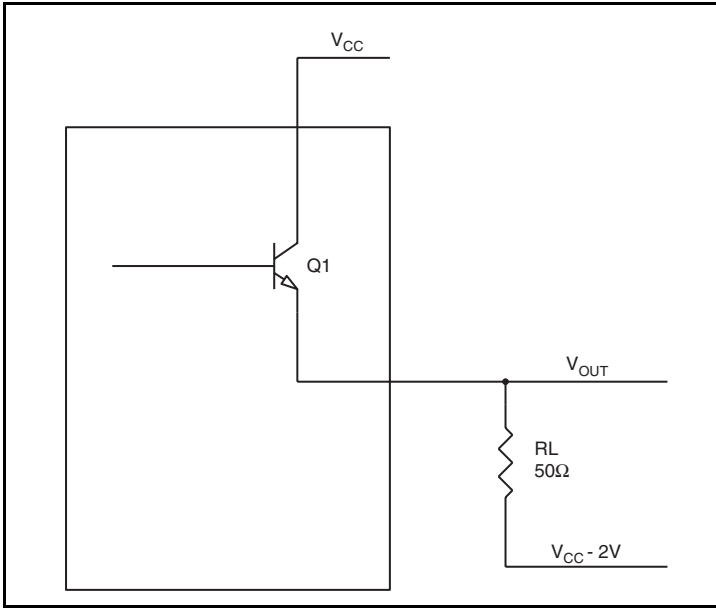

**Figure 11. LVPECL Driver Circuit and Termination**

To calculate worst case power dissipation into the load, use the following equations which assume a 50Ω load, and a termination voltage of  $V_{CC} - 2V$ .

- For logic high,  $V_{OUT} = V_{OH\_MAX} = V_{CC\_MAX} - 0.9V$   
 $(V_{CC\_MAX} - V_{OH\_MAX}) = 0.9V$
- For logic low,  $V_{OUT} = V_{OL\_MAX} = V_{CC\_MAX} - 1.7V$   
 $(V_{CC\_MAX} - V_{OL\_MAX}) = 1.7V$

$Pd\_H$  is power dissipation when the output drives high.

$Pd\_L$  is the power dissipation when the output drives low.

$$Pd\_H = [(V_{OH\_MAX} - (V_{CC\_MAX} - 2V))/R_L] * (V_{CC\_MAX} - V_{OH\_MAX}) = [(2V - (V_{CC\_MAX} - V_{OH\_MAX}))/R_L] * (V_{CC\_MAX} - V_{OH\_MAX}) = [(2V - 0.9V)/50\Omega] * 0.9V = \mathbf{19.8mW}$$

$$Pd\_L = [(V_{OL\_MAX} - (V_{CC\_MAX} - 2V))/R_L] * (V_{CC\_MAX} - V_{OL\_MAX}) = [(2V - (V_{CC\_MAX} - V_{OL\_MAX}))/R_L] * (V_{CC\_MAX} - V_{OL\_MAX}) = [(2V - 1.7V)/50\Omega] * 1.7V = \mathbf{10.2mW}$$

Total Power Dissipation per output pair =  $Pd\_H + Pd\_L = \mathbf{30mW}$

## LVDS Power Considerations

This section provides information on power dissipation and junction temperature for the ICS854S015I-01. Equations and example calculations are also provided.

### 1. Power Dissipation.

The total power dissipation for the ICS854S015I-01 is the sum of the core power plus the analog power plus the power dissipated in the load(s). The following is the power dissipation for  $V_{CC} = 3.3V + 5\% = 3.465V$ , which gives worst case results.

NOTE: Please refer to Section 3 for details on calculating power dissipated in the load.

- Power (core)<sub>MAX</sub> =  $V_{CC\_MAX} * I_{CC\_MAX} = 3.465V * 150mA = 519.75mW$

### 2. Junction Temperature.

Junction temperature,  $T_j$ , is the temperature at the junction of the bond wire and bond pad directly affects the reliability of the device. The maximum recommended junction temperature is 125°C. Limiting the internal transistor junction temperature,  $T_j$ , to 125°C ensures that the bond wire and bond pad temperature remains below 125°C.

The equation for  $T_j$  is as follows:  $T_j = \theta_{JA} * Pd\_total + T_A$

$T_j$  = Junction Temperature

$\theta_{JA}$  = Junction-to-Ambient Thermal Resistance

$Pd\_total$  = Total Device Power Dissipation (example calculation is in section 1 above)

$T_A$  = Ambient Temperature

In order to calculate junction temperature, the appropriate junction-to-ambient thermal resistance  $\theta_{JA}$  must be used. Assuming no air flow and a multi-layer board, the appropriate value is 49.5°C/W per Table 7 below.

Therefore,  $T_j$  for an ambient temperature of 85°C with all outputs switching is:

$$85^\circ\text{C} + 0.520\text{W} * 49.5^\circ\text{C/W} = 110.7^\circ\text{C}. \text{ This is below the limit of } 125^\circ\text{C}.$$

This calculation is only an example.  $T_j$  will obviously vary depending on the number of loaded outputs, supply voltage, air flow and the type of board (multi-layer).

**Table 7. Thermal Resistance  $\theta_{JA}$  for 24 Lead VFQFN, Forced Convection**

Meters per Second	$\theta_{JA}$ by Velocity		
	0	1	2.5
Multi-Layer PCB, JEDEC Standard Test Boards	49.5°C/W	43.3°C/W	38.8°C/W

## Reliability Information

**Table 8.  $\theta_{JA}$  vs. Air Flow Table for a 24 Lead VFQFN**

$\theta_{JA}$ vs. Air Flow			
Meters per Second	<b>0</b>	<b>1</b>	<b>2.5</b>
Multi-Layer PCB, JEDEC Standard Test Boards	49.5°C/W	43.3°C/W	38.8°C/W

## Transistor Count

The transistor count for ICS854S015I-01 is: 521

# Package Outline and Package Dimensions

## Package Outline - K Suffix for 24 Lead VFQFN

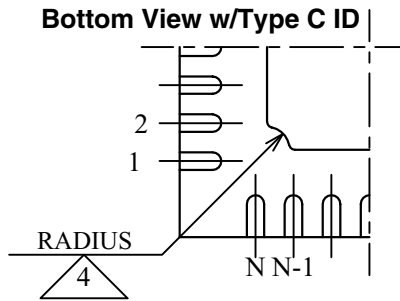
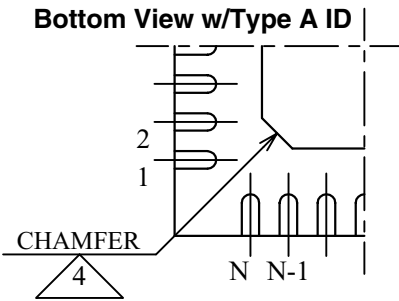
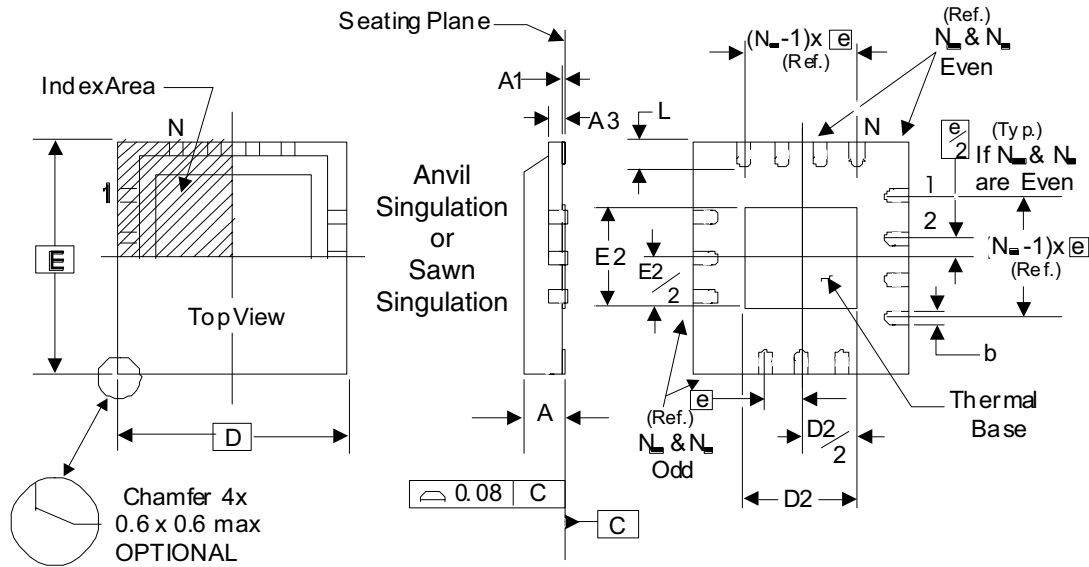

There are 2 methods of indicating pin 1 corner at the back of the VFQFN package are:

1. Type A: Chamfer on the paddle (near pin 1)
2. Type C: Mouse bite on the paddle (near pin 1)

**Table 9. K Package Dimensions for 24 Lead VFQFN**

All Dimensions in Millimeters		
Symbol	Minimum	Maximum
N	24	
A	0.80	1.0
A1	0	0.05
A3	0.25 Reference	
b	0.18	0.30
e	0.50 Basic	
D, E	4	
D2, E2	2.30	2.55
L	0.30	0.50
N <sub>D</sub> N <sub>E</sub>	6	

NOTE: The following package mechanical drawing is a generic drawing that applies to any pin count VFQFN package. This drawing is not intended to convey the actual pin count or pin layout of this device. The pin count and pinout are shown on the front page. The package dimensions are in Table 9.

Reference Document: JEDEC Publication 95, MO-220

## Ordering Information

Table 10. Ordering Information

Part/Order Number	Marking	Package	Shipping Packaging	Temperature
854S015CKI-01LF	15CI01L	"Lead-Free" 24 Lead VFQFN	Tube	-40°C to 85°C
854S015CKI-01LFT	15CI01L	"Lead-Free" 24 Lead VFQFN	2500 Tape & Reel	-40°C to 85°C

NOTE: Parts that are ordered with an "LF" suffix to the part number are the Pb-Free configuration and are RoHS compliant.



## IMPORTANT NOTICE AND DISCLAIMER

RENESAS ELECTRONICS CORPORATION AND ITS SUBSIDIARIES (“RENESAS”) PROVIDES TECHNICAL SPECIFICATIONS AND RELIABILITY DATA (INCLUDING DATASHEETS), DESIGN RESOURCES (INCLUDING REFERENCE DESIGNS), APPLICATION OR OTHER DESIGN ADVICE, WEB TOOLS, SAFETY INFORMATION, AND OTHER RESOURCES “AS IS” AND WITH ALL FAULTS, AND DISCLAIMS ALL WARRANTIES, EXPRESS OR IMPLIED, INCLUDING, WITHOUT LIMITATION, ANY IMPLIED WARRANTIES OF MERCHANTABILITY, FITNESS FOR A PARTICULAR PURPOSE, OR NON-INFRINGEMENT OF THIRD-PARTY INTELLECTUAL PROPERTY RIGHTS.

These resources are intended for developers who are designing with Renesas products. You are solely responsible for (1) selecting the appropriate products for your application, (2) designing, validating, and testing your application, and (3) ensuring your application meets applicable standards, and any other safety, security, or other requirements. These resources are subject to change without notice. Renesas grants you permission to use these resources only to develop an application that uses Renesas products. Other reproduction or use of these resources is strictly prohibited. No license is granted to any other Renesas intellectual property or to any third-party intellectual property. Renesas disclaims responsibility for, and you will fully indemnify Renesas and its representatives against, any claims, damages, costs, losses, or liabilities arising from your use of these resources. Renesas' products are provided only subject to Renesas' Terms and Conditions of Sale or other applicable terms agreed to in writing. No use of any Renesas resources expands or otherwise alters any applicable warranties or warranty disclaimers for these products.

(Disclaimer Rev.1.01 Jan 2024)

### Corporate Headquarters

TOYOSU FORESIA, 3-2-24 Toyosu,  
Koto-ku, Tokyo 135-0061, Japan  
[www.renesas.com](http://www.renesas.com)

### Trademarks

Renesas and the Renesas logo are trademarks of Renesas Electronics Corporation. All trademarks and registered trademarks are the property of their respective owners.

### Contact Information

For further information on a product, technology, the most up-to-date version of a document, or your nearest sales office, please visit [www.renesas.com/contact-us/](http://www.renesas.com/contact-us/).

## Looking for pricing, stock, or lifecycle information?

Click below to explore more details on WIN SOURCE:

-  [View 854S015CKI-01LF on WIN SOURCE](#)
-  [Renesas Electronics America](#) Information

## Optimize Your Supply Chain with WIN SOURCE Solutions

-  Global Sourcing Solution
-  Obsolete Management
-  Cost Control Management
-  Shortage Management
-  Alternative Solution
-  Excess Inventory Management