

General Description

The 813N252DI-02 device uses IDT's fourth generation FemtoClock[®] NG technology for optimal high clock frequency and low phase noise performance, combined with a low power consumption and high power supply noise rejection. The 813N252DI-02 is a PLL based synchronous multiplier that is optimized for PDH or SONET to Ethernet clock jitter attenuation and frequency translation.

The 813N252DI-02 is a fully integrated Phase Locked loop utilizing a FemtoClock NG Digital VCXO that provides the low jitter, high frequency SONET/PDH output clock that easily meets OC-48 jitter requirements. This VCXO technology simplifies PLL design by replacing the pullable crystal requirement of analog VCXOs with a fixed 27MHz generator crystal. Jitter attenuation down to 10Hz is provided by an external loop filter. Pre-divider and output divider multiplication ratios are selected using device selection control pins. The multiplication ratios are optimized to support most common clock rates used in PDH, SONET and Ethernet applications. The device requires the use of an external, inexpensive fundamental mode 27MHz crystal. The device is packaged in a space-saving 32-VFQFN package and supports industrial temperature range.

Pin Assignment

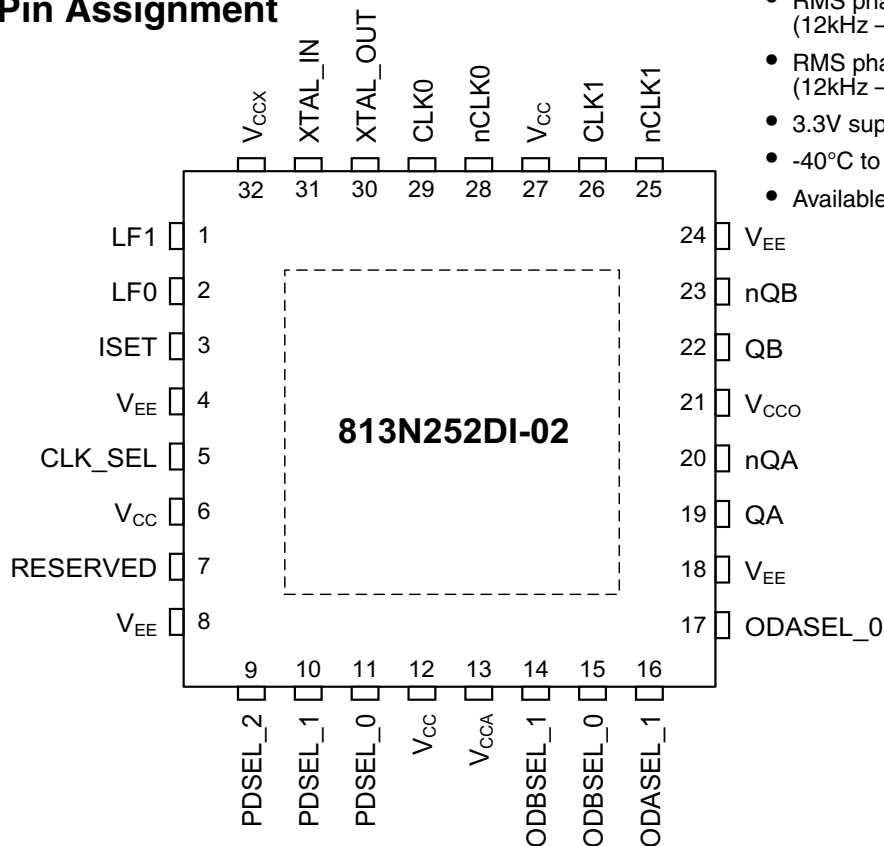

32-pin, 5mm x 5mm VFQFN Package

Features

- Fourth generation FemtoClock[®] NG technology
- Two LVPECL output pairs
- Each output supports independent frequency selection at 25MHz, 125MHz, 156.25MHz and 312.5MHz
- Two differential inputs support the following input types: LVPECL, LVDS, LVHSTL, HCSL
- Accepts input frequencies from 8kHz to 155.52MHz including 8kHz, 1.544MHz, 2.048MHz, 19.44MHz, 25MHz, 77.76MHz, 125MHz and 155.52MHz
- Crystal interface optimized for a 27MHz, 10pF parallel resonant crystal
- Attenuates the phase jitter of the input clock by using a low-cost fundamental mode crystal
- Customized settings for jitter attenuation and reference tracking using an external loop filter connection
- FemtoClock NG frequency multiplier provides low jitter, high frequency output
- Absolute pull range: ± 100 ppm
- Power supply noise rejection (PSNR): -85dB (typical)
- FemtoClock NG VCXO frequency: 2500MHz
- RMS phase jitter @ 156.25MHz, using a 27MHz crystal (12kHz – 20MHz): 0.6ps (typical)
- RMS phase jitter @ 125MHz, using a 27MHz crystal (12kHz – 20MHz): 0.65ps (typical)
- 3.3V supply voltage
- -40°C to 85°C ambient operating temperature
- Available in lead-free (RoHS 6) package

Block Diagram

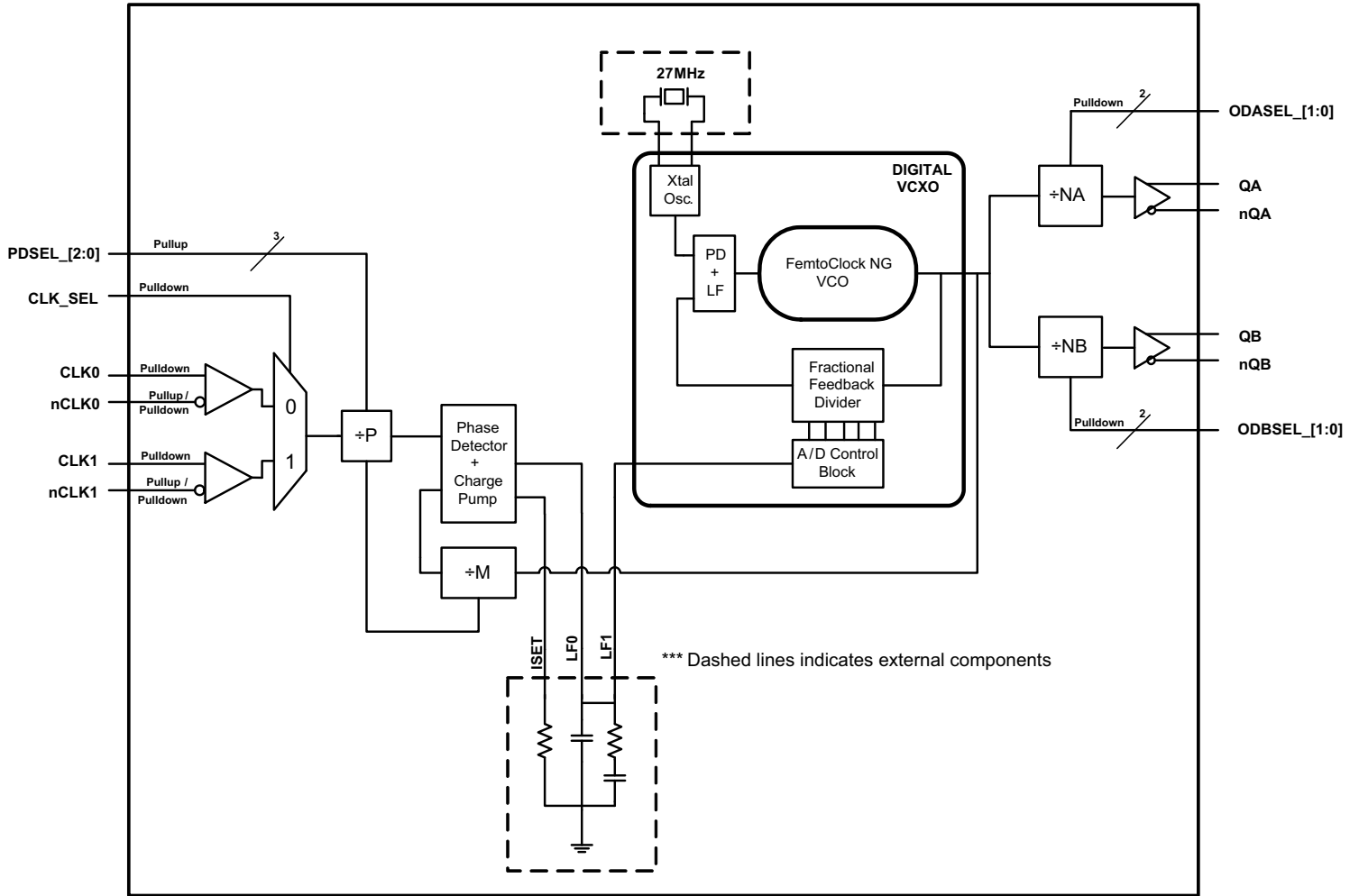

Pin Description and Pin Characteristic Tables

Table 1. Pin Descriptions

Number	Name	Type		Description
1, 2	LF1, LF0	Analog Input/Output		Loop filter connection node pins. LF0 is the output. LF1 is the input.
3	ISET	Analog Input/Output		Charge pump current setting pin.
4, 8, 18, 24	V _{EE}	Power		Negative supply pins.
5	CLK_SEL	Input	Pulldown	Input clock select. When HIGH selects CLK1, nCLK1. When LOW, selects CLK0, nCLK0. LVCMOS / LVTTTL interface levels.
6, 12, 27	V _{CC}	Power		Core supply pins.
7	RESERVED	Reserve		Reserved pin.
9, 10, 11	PDSEL_2, PDSEL_1, PDSEL_0	Input	Pullup	Pre-divider select pins. LVCMOS/LVTTTL interface levels. See Table 3A.
13	V _{CCA}	Power		Analog supply pin.
14, 15	ODBSEL_1, ODBSEL_0	Input	Pulldown	Frequency select pins for Bank B output. See Table 3B. LVCMOS/LVTTTL interface levels.
16, 17	ODASEL_1, ODASEL_0	Input	Pulldown	Frequency select pins for Bank A output. See Table 3B. LVCMOS/LVTTTL interface levels.
19, 20	QA, nQA	Output		Differential Bank A clock outputs. LVPECL interface levels.
21	V _{CCO}	Power		Output supply pin.
22, 23	QB, nQB	Output		Differential Bank B clock outputs. LVPECL interface levels.
25	nCLK1	Input	Pullup/ Pulldown	Inverting differential clock input. V _{CC} /2 bias voltage when left floating.
26	CLK1	Input	Pulldown	Non-inverting differential clock input.
28	nCLK0	Input	Pullup/ Pulldown	Inverting differential clock input. V _{CC} /2 bias voltage when left floating.
29	CLK0	Input	Pulldown	Non-inverting differential clock input.
30, 31	XTAL_OUT, XTAL_IN	Input		Crystal oscillator interface. XTAL_IN is the input. XTAL_OUT is the output.
32	V _{CCX}	Power		Power supply pin for the crystal oscillator.

NOTE: *Pullup and Pulldown* refer to internal input resistors. See Table 2, *Pin Characteristics*, for typical values.

Table 2. Pin Characteristics

Symbol	Parameter	Test Conditions	Minimum	Typical	Maximum	Units
C _{IN}	Input Capacitance			2		pF
R _{PULLUP}	Input Pullup Resistor			51		kΩ
R _{PULLDOWN}	Input Pulldown Resistor			51		kΩ

Function Tables

Table 3A. Pre-Divider Selection Function Table

Inputs			÷P Value
PDSEL_2	PDSEL_1	PDSEL_0	
0	0	0	1
0	0	1	193
0	1	0	256
0	1	1	1944
1	0	0	2500
1	0	1	7776
1	1	0	12500
1	1	1	15552 (default)

Table 3B. Output Divider Function Table

Inputs		÷Nx Value
ODxSEL_1	ODxSEL_0	
0	0	100 (default)
0	1	20
1	0	16
1	1	8

NOTE: x denotes A or B.

Table 3C. Frequency Function Table

Input Frequency (MHz)	÷P Value	FemtoClock NG VCXO Center Frequency (MHz)	÷Nx Value	Output Frequency (MHz)
0.008	1	2500	100	25
0.008	1	2500	20	125
0.008	1	2500	16	156.25
0.008	1	2500	8	312.5
1.544	193	2500	100	25
1.544	193	2500	20	125
1.544	193	2500	16	156.25
1.544	193	2500	8	312.5
2.048	256	2500	100	25
2.048	256	2500	20	125
2.048	256	2500	16	156.25
2.048	256	2500	8	312.5
19.44	1944	2500	100	25
19.44	1944	2500	20	125
19.44	1944	2500	16	156.25
19.44	1944	2500	8	312.5
25	2500	2500	100	25
25	2500	2500	20	125
25	2500	2500	16	156.25
25	2500	2500	8	312.5
77.76	7776	2500	100	25
77.76	7776	2500	20	125
77.76	7776	2500	16	156.25
77.76	7776	2500	8	312.5
125	12500	2500	100	25
125	12500	2500	20	125
125	12500	2500	16	156.25
125	12500	2500	8	312.5
155.52	15552	2500	100	25
155.52	15552	2500	20	125
155.52	15552	2500	16	156.25
155.52	15552	2500	8	312.5

NOTE: x denotes A or B.

Absolute Maximum Ratings

NOTE: Stresses beyond those listed under *Absolute Maximum Ratings* may cause permanent damage to the device. These ratings are stress specifications only. Functional operation of product at these conditions or any conditions beyond those listed in the *DC Characteristics* or *AC Characteristics* is not implied. Exposure to absolute maximum rating conditions for extended periods may affect product reliability.

Item	Rating
Supply Voltage, V_{CC}	3.63V
Inputs, V_I XTAL_IN Other Inputs	0V to 2V -0.5V to $V_{CC} + 0.5V$
Outputs, I_O Continuous Current Surge Current	50mA 100mA
Package Thermal Impedance, θ_{JA}	33.1°C/W (0 mps)
Storage Temperature, T_{STG}	-65°C to 150°C

DC Electrical Characteristics

Table 4A. LVPECL Power Supply DC Characteristics, $V_{CC} = V_{CCO} = V_{CCX} = 3.3V \pm 5\%$, $V_{EE} = 0V$, $T_A = -40^\circ C$ to $85^\circ C$

Symbol	Parameter	Test Conditions	Minimum	Typical	Maximum	Units
V_{CC}	Core Supply Voltage		3.135	3.3	3.465	V
V_{CCA}	Analog Supply Voltage		$V_{CC} - 0.30$	3.3	V_{CC}	V
V_{CCO}	Output Supply Voltage		3.135	3.3	3.465	V
V_{CCX}	Crystal Supply Voltage		3.135	3.3	3.465	V
I_{EE}	Power Supply Current			253	321	mA
I_{CCA}	Analog Supply Current				30	mA

Table 4B. LVCMOS/LVTTL DC Characteristics, $V_{CC} = V_{CCO} = V_{CCX} = 3.3V \pm 5\%$, $T_A = -40^\circ C$ to $85^\circ C$

Symbol	Parameter	Test Conditions	Minimum	Typical	Maximum	Units
V_{IH}	Input High Voltage		2		$V_{CC} + 0.3$	V
V_{IL}	Input Low Voltage		-0.3		0.8	V
I_{IH}	Input High Current	CLK_SEL, ODASEL_[1:0], ODBSEL_[1:0]	$V_{CC} = V_{IN} = 3.465V$		150	μA
		PDSEL_[2:0]	$V_{CC} = V_{IN} = 3.465V$		10	μA
I_{IL}	Input Low Current	CLK_SEL, ODASEL_[1:0], ODBSEL_[1:0]	$V_{CC} = 3.465V, V_{IN} = 0V$	-10		μA
		PDSEL_[2:0]	$V_{CC} = 3.465, V_{IN} = 0V$	-150		μA

Table 4C. Differential DC Characteristics, $V_{CC} = V_{CCO} = V_{CCX} = 3.3V \pm 5\%$, $T_A = -40^{\circ}C$ to $85^{\circ}C$

Symbol	Parameter	Test Conditions	Minimum	Typical	Maximum	Units
I_{IH}	Input High Current	CLK0, nCLK0, CLK1, nCLK1 $V_{CC} = V_{IN} = 3.465V$			150	μA
I_{IL}	Input Low Current	CLK0, CLK1 $V_{CC} = 3.465V, V_{IN} = 0V$	-10			μA
		nCLK0, nCLK1 $V_{CC} = 3.465V, V_{IN} = 0V$	-150			μA
V_{PP}	Peak-to-Peak Input Voltage; NOTE 1		0.15		1.3	V
V_{CMR}	Common Mode Input Voltage; NOTE 1, 2		V_{EE}		$V_{CC} - 0.85$	V

NOTE 1: V_{IL} should not be less than -0.3V.

NOTE 2. Common mode voltage is defined at the crosspoint.

Table 4D. LVPECL DC Characteristics, $V_{CC} = V_{CCO} = V_{CCX} = 3.3V \pm 5\%$, $V_{EE} = 0V$, $T_A = -40^{\circ}C$ to $85^{\circ}C$

Symbol	Parameter	Test Conditions	Minimum	Typical	Maximum	Units
V_{OH}	Output High Voltage; NOTE 1		$V_{CCO} - 1.10$		$V_{CCO} - 0.75$	V
V_{OL}	Output Low Voltage; NOTE 1		$V_{CCO} - 2.0$		$V_{CCO} - 1.6$	V
V_{SWING}	Peak-to-Peak Output Voltage Swing		0.6		1.0	V

NOTE 1: Outputs terminated with 50Ω to $V_{CCO} - 2V$. See Parameter Measurement Information section, *3.3V Output Load Test Circuit*.

AC Electrical Characteristics

Table 5. AC Characteristics, $V_{CC} = V_{CCO} = V_{CCX} = 3.3V \pm 5\%$, $T_A = -40^\circ\text{C}$ to 85°C

Symbol	Parameter	Test Conditions	Minimum	Typical	Maximum	Units
f_{IN}	Input Frequency		0.008		155.52	MHz
f_{OUT}	Output Frequency		25		312.5	MHz
$f_{jit}(\emptyset)$	RMS Phase Jitter, (Random), NOTE 1	125MHz f_{OUT} , 27MHz crystal, Integration Range: 12kHz – 20MHz		0.65		ps
		156.25MHz f_{OUT} , 27MHz crystal, Integration Range: 12kHz – 20MHz		0.6		ps
PSNR	Power Supply Noise Rejection; NOTE 2	$V_{PP} = 50\text{mV}$ Sine Wave, Range: 10kHz – 10MHz		-85		dB
$t_{sk(o)}$	Output Skew; NOTE 3, 4				80	ps
t_R / t_F	Output Rise/Fall Time	20% to 80%	150		450	ps
odc	Output Duty Cycle		48		52	%
t_{LOCK}	Output-to-Input Phase Lock Time; NOTE 5	Reference Clock Input is $\pm 100\text{ppm}$ from Nominal Frequency		4		s

NOTE: Electrical parameters are guaranteed over the specified ambient operating temperature range, which is established when the device is mounted in a test socket with maintained transverse airflow greater than 500 lpm. The device will meet specifications after thermal equilibrium has been reached under these conditions.

NOTE: Characterized with outputs at the same frequency using the loop filter components for the 35Hz loop bandwidth. Refer to Jitter Attenuator Loop Bandwidth Selection Table.

NOTE 1: Refer to the Phase Noise Plot.

NOTE 2: PSNR results achieved by injecting noise on V_{CCA} supply pin with no external filter network.

NOTE 3: This parameter is defined in accordance with JEDEC Standard 65.

NOTE 4: Defined as skew between outputs at the same supply voltage and with equal load conditions. Measured at the output differential cross points.

NOTE 5: Lock Time measured from power-up to stable output frequency.

Typical Phase Noise at 125MHz

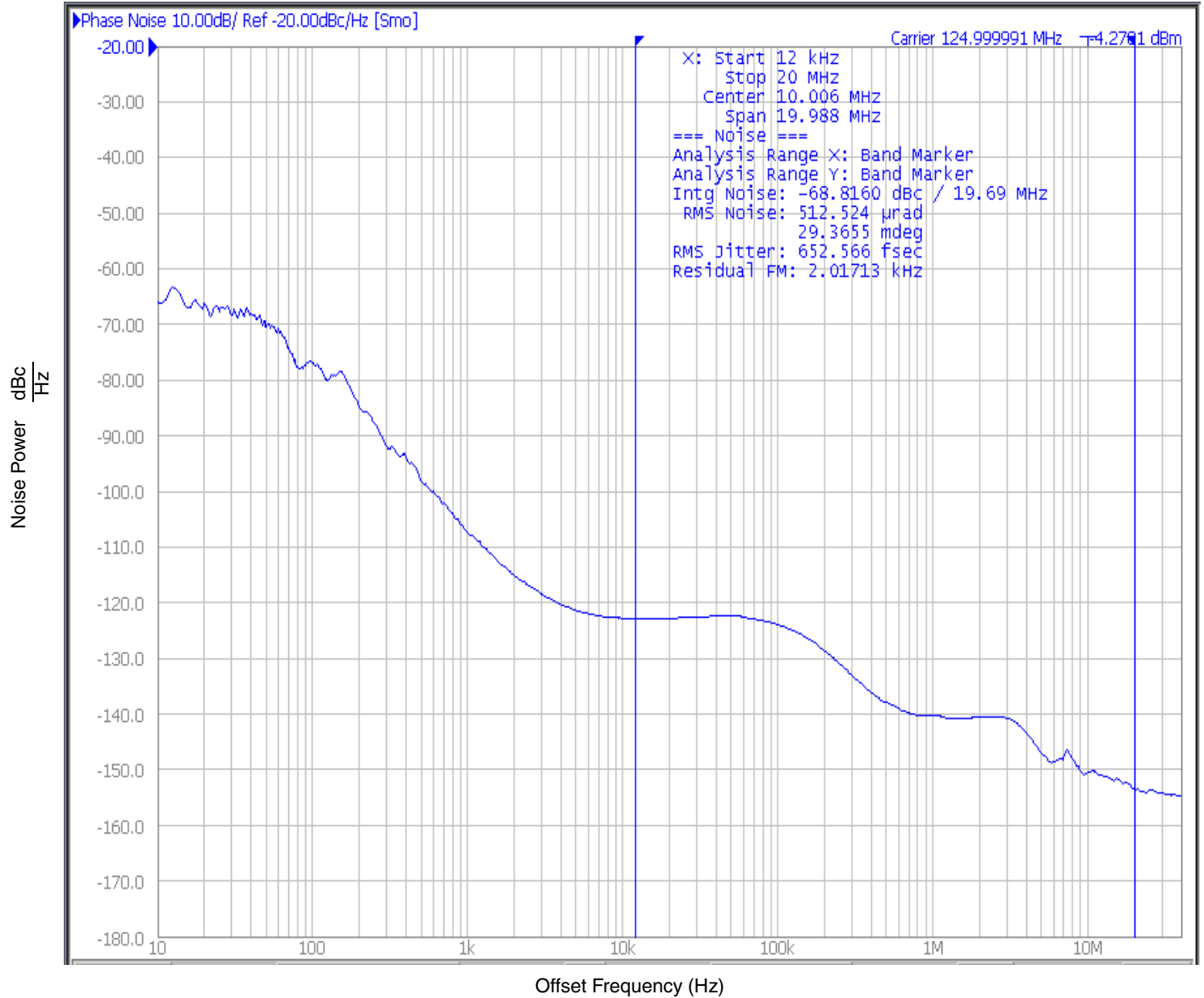

Parameter Measurement Information

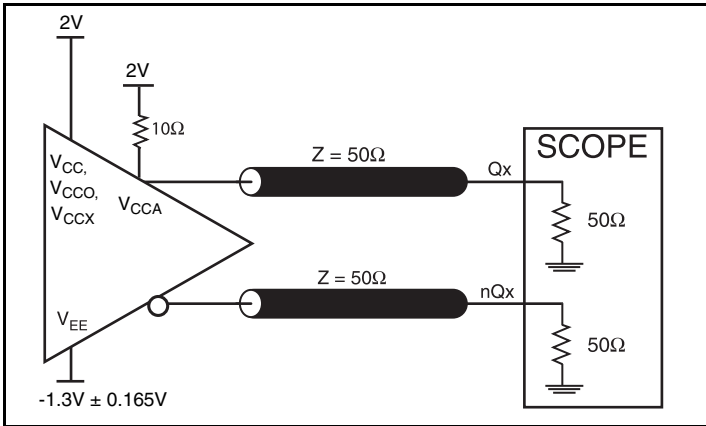

3.3V LVPECL Output Load AC Test Circuit

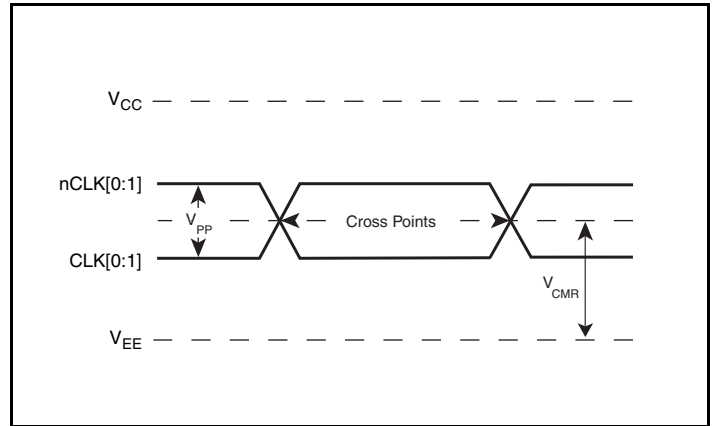

Differential Input Level

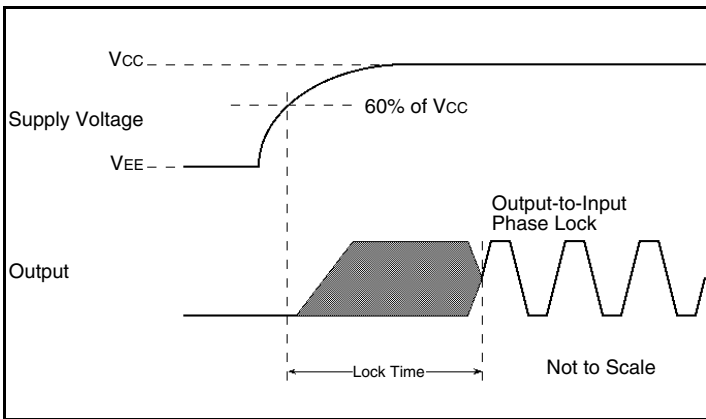

Output-to-Input Phase Lock Time

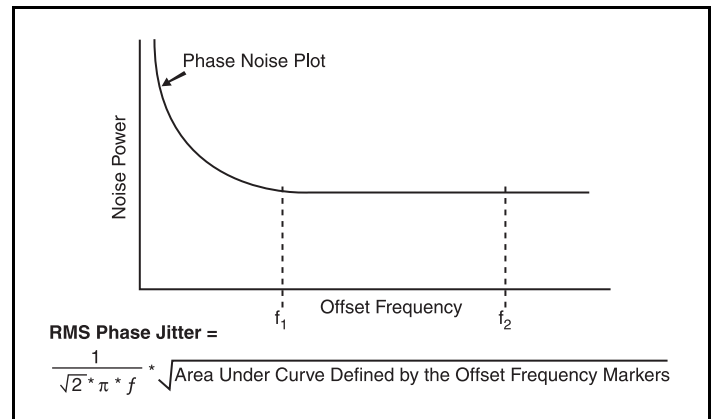

RMS Phase Jitter

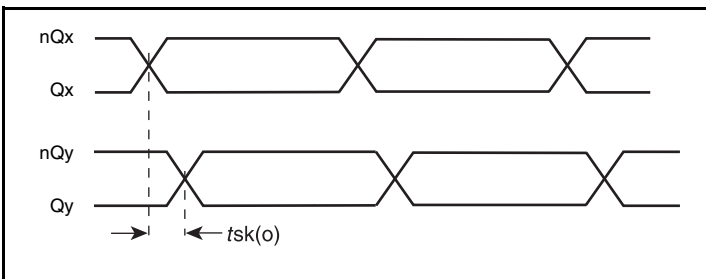

Output Skew

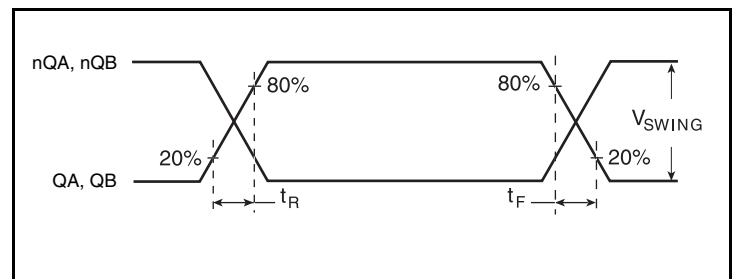

LVPECL Output Rise/Fall Time

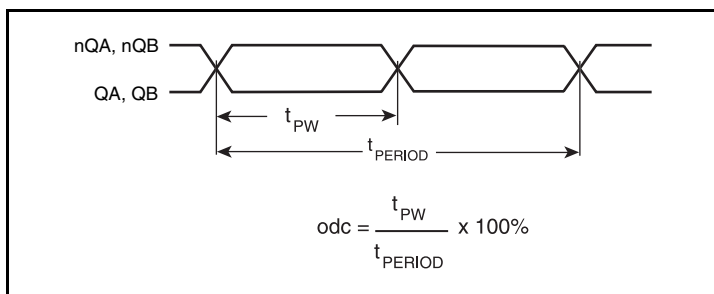

Output Duty Cycle/Pulse Width/Period

Applications Information

Wiring the Differential Input to Accept Single-Ended Levels

Figure 1 shows how a differential input can be wired to accept single ended levels. The reference voltage $V_1 = V_{CC}/2$ is generated by the bias resistors R1 and R2. The bypass capacitor (C1) is used to help filter noise on the DC bias. This bias circuit should be located as close to the input pin as possible. The ratio of R1 and R2 might need to be adjusted to position the V_1 in the center of the input voltage swing. For example, if the input clock is driven from a single-ended 2.5V LVCMOS driver and the DC offset (or swing center) of this signal is 1.25V, the R1 and R2 values should be adjusted to set the V_1 at 1.25V. The values below are for when both the single ended swing and V_{CC} are at the same voltage. This configuration requires that the sum of the output impedance of the driver (R_o) and the series resistance (R_s) equals the transmission line impedance. In addition, matched termination at the input will attenuate the signal in half. This can be done in one of two ways. First, R3 and R4 in parallel should

equal the transmission line impedance. For most 50Ω applications, R3 and R4 can be 100Ω. The values of the resistors can be increased to reduce the loading for slower and weaker LVCMOS driver. When using single-ended signaling, the noise rejection benefits of differential signaling are reduced. Even though the differential input can handle full rail LVCMOS signaling, it is recommended that the amplitude be reduced while maintaining an edge rate faster than 1V/ns. The datasheet specifies a lower differential amplitude, however this only applies to differential signals. For single-ended applications, the swing can be larger, however V_{IL} cannot be less than -0.3V and V_{IH} cannot be more than $V_{CC} + 0.3V$. Though some of the recommended components might not be used, the pads should be placed in the layout. They can be utilized for debugging purposes. The datasheet specifications are characterized and guaranteed by using a differential signal.

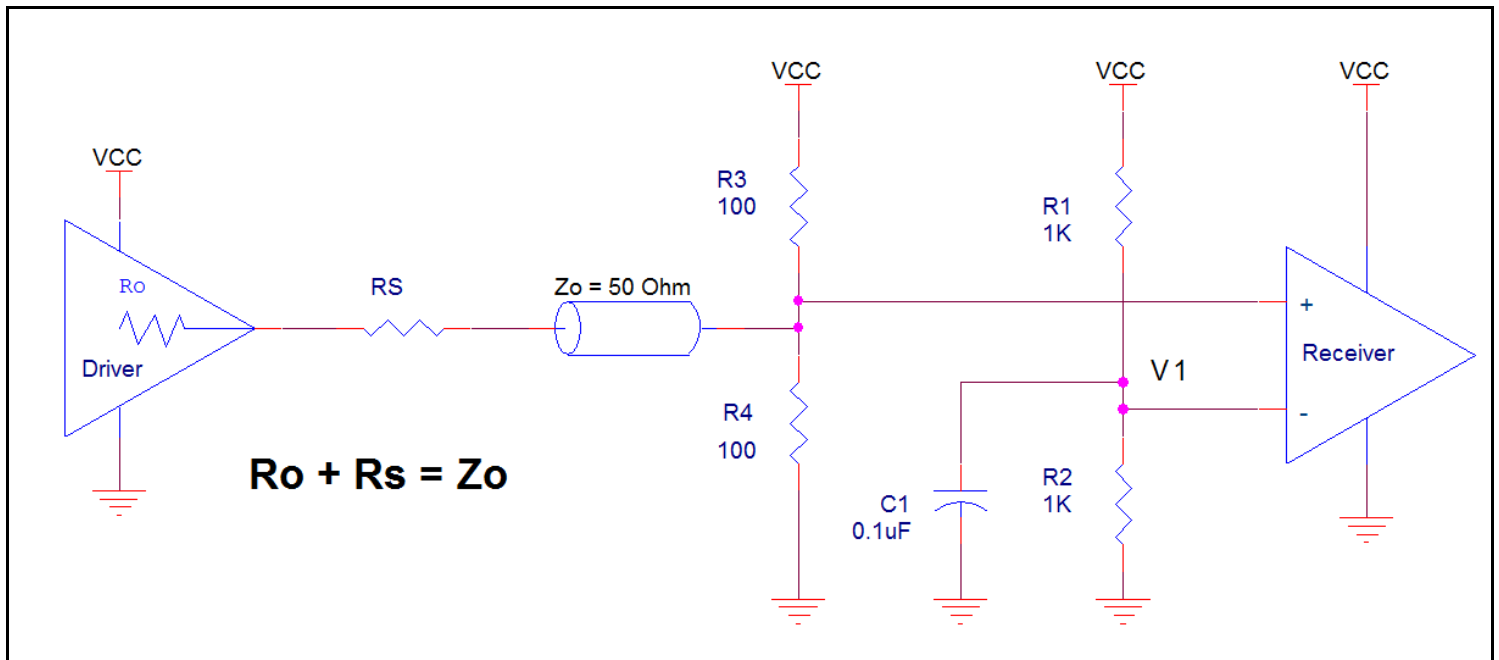

Figure 1. Recommended Schematic for Wiring a Differential Input to Accept Single-ended Levels

3.3V Differential Clock Input Interface

The CLK /nCLK accepts LVDS, LVPECL, LVHSTL, HCSL and other differential signals. Both differential inputs must meet the V_{PP} and V_{CMR} input requirements. *Figures 2A to 2E* show interface examples for the CLK /nCLK input driven by the most common driver types. The input interfaces suggested here are examples only. Please consult

with the vendor of the driver component to confirm the driver termination requirements. For example, in Figure 2A, the input termination applies for IDT open emitter LVHSTL drivers. If you are using an LVHSTL driver from another vendor, use their termination recommendation.

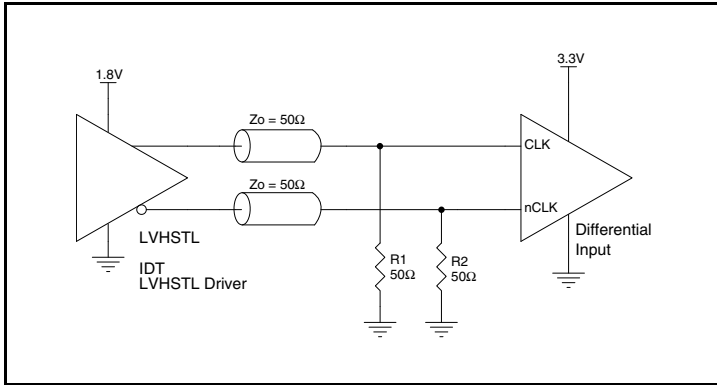

Figure 2A. CLK/nCLK Input Driven by an IDT Open Emitter LVHSTL Driver

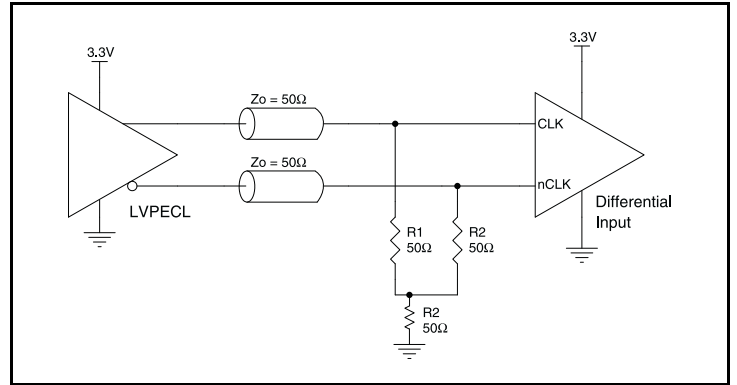

Figure 2B. CLK/nCLK Input Driven by a 3.3V LVPECL Driver

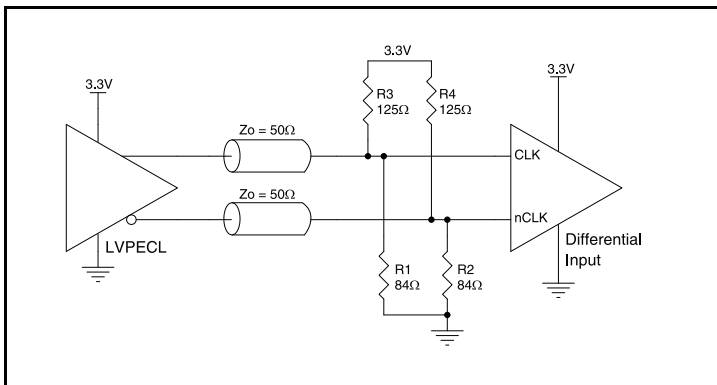

Figure 2C. CLK/nCLK Input Driven by a 3.3V LVPECL Driver

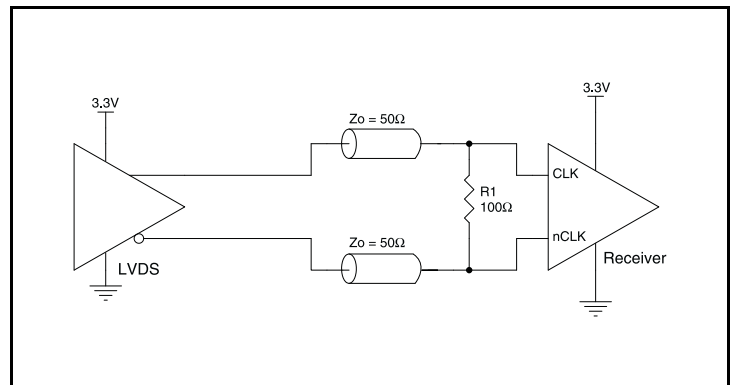

Figure 2D. CLK/nCLK Input Driven by a 3.3V LVDS Driver

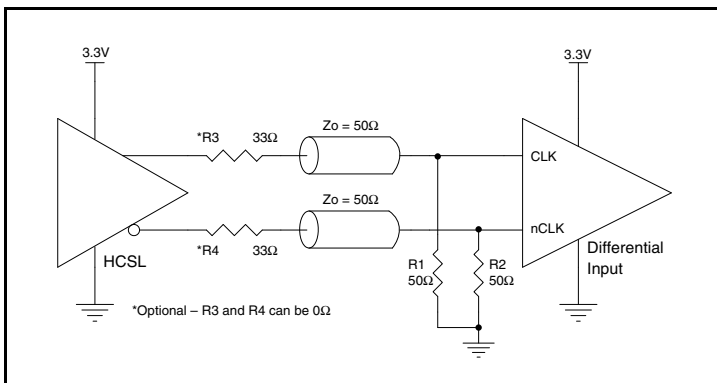

Figure 2E. CLK/nCLK Input Driven by an HCSL Driver

Recommendations for Unused Input and Output Pins

Inputs:

CLK/nCLK Inputs

For applications requiring only one differential input, the unused CLKx and nCLKx pins can be left floating. Though not required, but for additional protection, a 1kΩ resistor can be tied from the unused CLK input to ground.

LVC MOS Control Pins

All control pins have internal pullups or pulldowns; additional resistance is not required but can be added for additional protection. A 1kΩ resistor can be used.

Outputs:

LVPECL Outputs

All unused LVPECL outputs can be left floating. We recommend that there is no trace attached. Both sides of the differential output pair should either be left floating or terminated.

Termination for 3.3V LVPECL Outputs

The clock layout topology shown below is a typical termination for LVPECL outputs. The two different layouts mentioned are recommended only as guidelines.

The differential output is a low impedance follower output that generate ECL/LVPECL compatible outputs. Therefore, terminating resistors (DC current path to ground) or current sources must be used for functionality. These outputs are designed to drive 50Ω

transmission lines. Matched impedance techniques should be used to maximize operating frequency and minimize signal distortion. Figures 3A and 3B show two different layouts which are recommended only as guidelines. Other suitable clock layouts may exist and it would be recommended that the board designers simulate to guarantee compatibility across all printed circuit and clock component process variations.

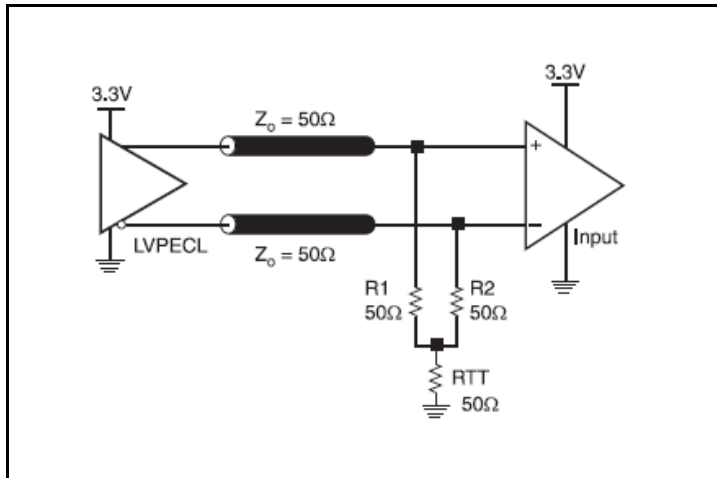

Figure 3A. 3.3V LVPECL Output Termination

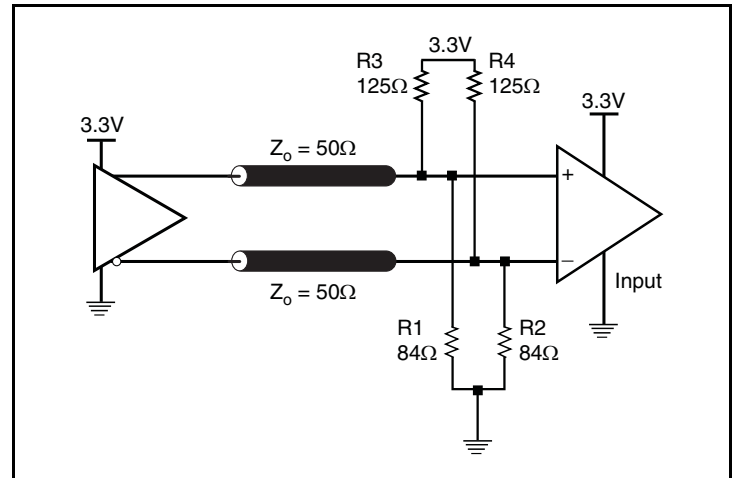

Figure 3B. 3.3V LVPECL Output Termination

Jitter Attenuator EXTERNAL COMPONENTS

Choosing the correct external components and having a proper printed circuit board (PCB) layout is a key task for quality operation of the Jitter Attenuator. In choosing a crystal, special precaution must be taken with load capacitance (C_L), frequency accuracy and temperature range.

The crystal's C_L characteristic determines its resonating frequency and is closely related to the center tuning of the crystal. The total external capacitance ($C_{EXTERNAL}$) seen by the crystal when installed on a PCB is the sum of the stray board capacitance, IC package lead capacitance, internal device capacitance and any installed tuning capacitors (C_{TUNE}). The recommended C_L in the *Crystal Parameter Table* balances the tuning range by centering the tuning curve for a typical PCB. If the crystal C_L is greater than the total external capacitance ($C_L > C_{EXTERNAL}$), the crystal will oscillate at a higher frequency than the specification. If the crystal C_L is lower than the total external capacitance ($C_L < C_{EXTERNAL}$), the crystal will oscillate at a lower frequency than the specification. Mismatches between C_L and $C_{EXTERNAL}$ require adjustments in C_{TUNE} in order to center the tuning curve. For example, given a board with 5pF of stray capacitance, C_{TUNE} would be 0. In addition, the frequency accuracy

specification in the *Crystal Characteristics Table* are used to calculate the APR (Absolute Pull Range). It is recommended that the crystal C_L not to exceed the value stated in the *Crystal Parameter Table* because it can lead to a reduced APR

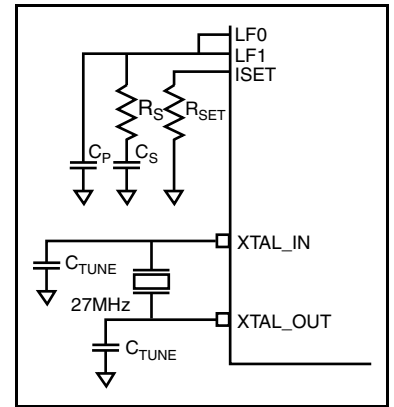

Crystal Characteristics

Symbol	Parameter	Test Conditions	Minimum	Typical	Maximum	Units
	Mode of Oscillation		Fundamental			
f_N	Frequency			27		MHz
f_T	Frequency Tolerance				±20	ppm
f_S	Frequency Stability				±20	ppm
	Operating Temperature Range		-40		+85	°C
C_L	Load Capacitance			10		pF
C_O	Shunt Capacitance			4		pF
ESR	Equivalent Series Resistance				40	Ω
	Drive Level			100	1	μW
	Aging @ 25 °C	First Year			±3	ppm

The VCXO-PLL Loop Bandwidth Selection Table shows R_S , C_S , C_P and R_{SET} values for recommended high, mid and low loop bandwidth configurations. The device has been characterized using these parameters. In addition, the digital VCXO gain (k_{VCXO}) has been provided for additional loop filter requirements.

Jitter Attenuator Characteristics Table

Symbol	Parameter	Typical	Units
k_{VCXO}	VCXO Gain	2.6	kHz/V

Jitter Attenuator Loop Bandwidth Selection Table

Bandwidth	Crystal Frequency	R_S (kΩ)	C_S (μF)	C_P (μF)	R_{SET} (kΩ)
7Hz (Low)	27MHz	110	10	0.01	2.21
35Hz (Mid)	27MHz	365	1	0.002	1.5
45Hz (High)	27MHz	470	1	0.0005	1.5

The crystal and external loop filter components should be kept as close as possible to the device. Loop filter and crystal traces should be kept short and separated from each other. Other signal traces

should be kept separate and not run underneath the device, loop filter or crystal components.

VFQFN EPAD Thermal Release Path

In order to maximize both the removal of heat from the package and the electrical performance, a land pattern must be incorporated on the Printed Circuit Board (PCB) within the footprint of the package corresponding to the exposed metal pad or exposed heat slug on the package, as shown in *Figure 4*. The solderable area on the PCB, as defined by the solder mask, should be at least the same size/shape as the exposed pad/slug area on the package to maximize the thermal/electrical performance. Sufficient clearance should be designed on the PCB between the outer edges of the land pattern and the inner edges of pad pattern for the leads to avoid any shorts.

While the land pattern on the PCB provides a means of heat transfer and electrical grounding from the package to the board through a solder joint, thermal vias are necessary to effectively conduct from the surface of the PCB to the ground plane(s). The land pattern must be connected to ground through these vias. The vias act as “heat pipes”. The number of vias (i.e. “heat pipes”) are application specific

and dependent upon the package power dissipation as well as electrical conductivity requirements. Thus, thermal and electrical analysis and/or testing are recommended to determine the minimum number needed. Maximum thermal and electrical performance is achieved when an array of vias is incorporated in the land pattern. It is recommended to use as many vias connected to ground as possible. It is also recommended that the via diameter should be 12 to 13mils (0.30 to 0.33mm) with 1oz copper via barrel plating. This is desirable to avoid any solder wicking inside the via during the soldering process which may result in voids in solder between the exposed pad/slug and the thermal land. Precautions should be taken to eliminate any solder voids between the exposed heat slug and the land pattern. Note: These recommendations are to be used as a guideline only. For further information, please refer to the Application Note on the Surface Mount Assembly of Amkor’s Thermally/Electrically Enhance Leadframe Base Package, Amkor Technology.

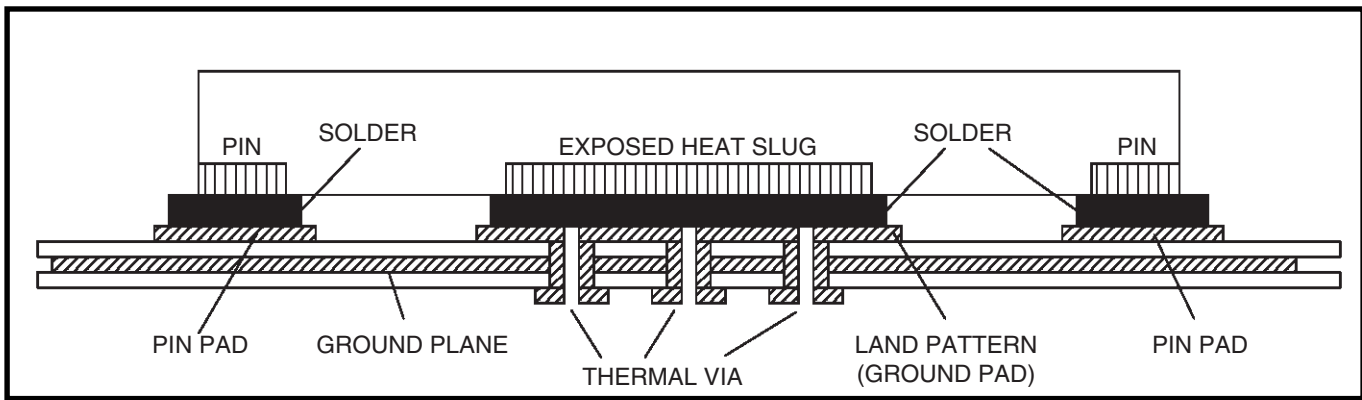

Figure 4. P.C. Assembly for Exposed Pad Thermal Release Path – Side View (drawing not to scale)

Schematic Example

Figure 5 (on next page) shows an example of 813N252DI-02 application schematic. In this example, the device is operated at $V_{CC} = V_{CCX} = V_{CCO} = 3.3V$. A 10pF parallel resonant 27MHz crystal is used. Spare placement pads for the load capacitance C1 and C2 are recommended for frequency accuracy. Depending on the parasitics of the printed circuit board layout, these values might require a slight adjustment to optimize the frequency accuracy. Crystals with other load capacitance specifications can be used. This will require adjusting C1 and C2.

An Optional 3-pole filter can also be used for additional spur reduction. It is recommended that the loop filter components be laid out for the 3-pole option. This will allow the flexibility for the 2-pole filter to be used.

As with any high speed analog circuitry, the power supply pins are vulnerable to noise. To achieve optimum jitter performance, power supply isolation is required. The 813N252DI-02 provides separate power supplies to isolate from coupling into the internal PLL.

In order to achieve the best possible filtering, it is recommended that the placement of the filter components be on the device side of the PCB as close to the power pins as possible. If space is limited, the 0.1μF capacitor in each power pin filter should be placed on the device side of the PCB and the other components can be placed on the opposite side.

Power supply filter recommendations are a general guideline to be used for reducing external noise from coupling into the devices. The filter performance is designed for wide range of noise frequencies. This low-pass filter starts to attenuate noise at approximately 10kHz. If a specific frequency noise component is known, such as switching power supply frequencies, it is recommended that component values be adjusted and if required, additional filtering be added. Additionally, good general design practices for power plane voltage stability suggests adding bulk capacitances in the local area of all devices.

The schematic example focuses on functional connections and is not configuration specific. Refer to the pin description and functional tables in the datasheet to ensure the logic control inputs are properly set.

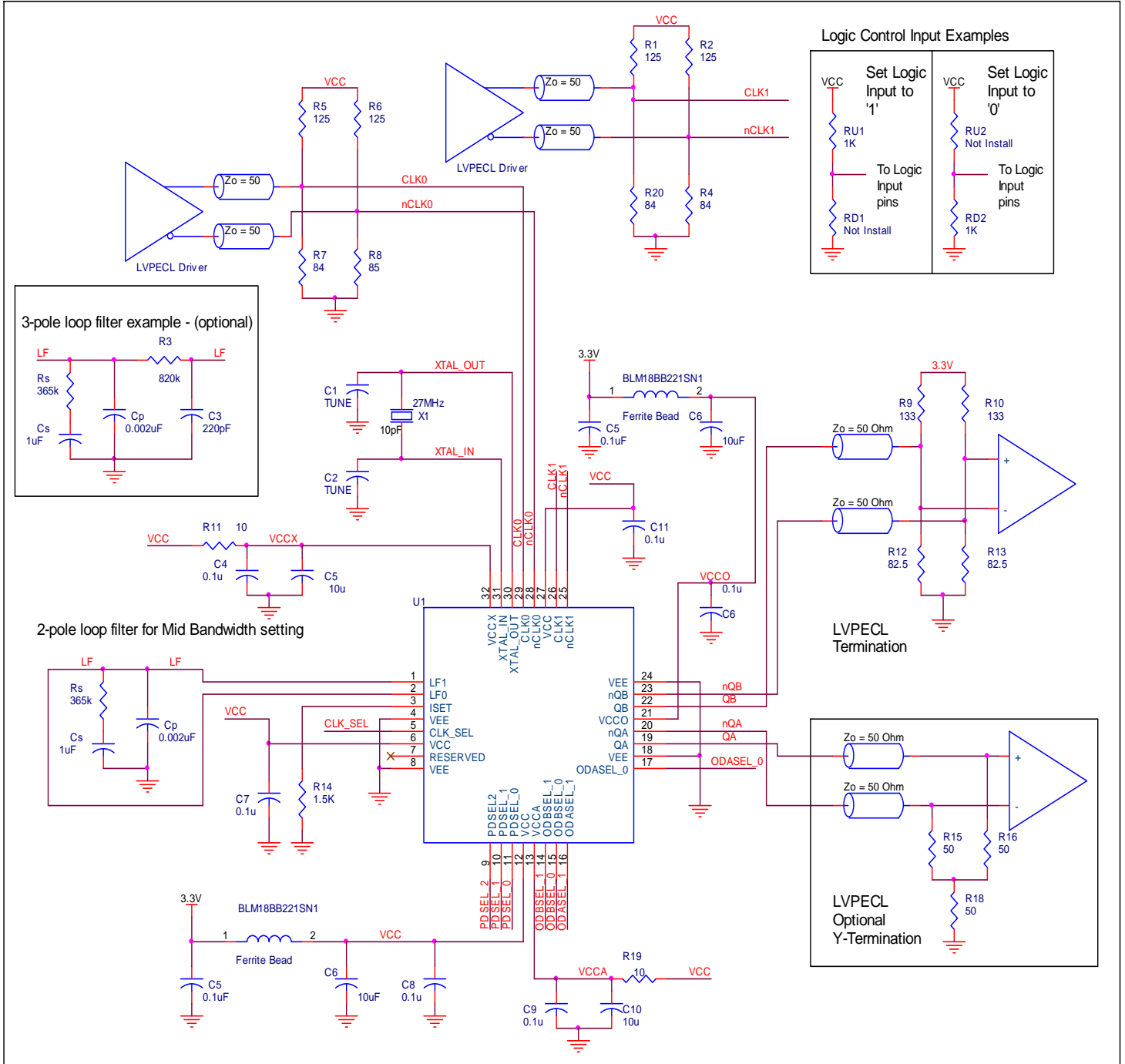

Figure 5. 813N252DI-02 Schematic Example

Power Considerations

This section provides information on power dissipation and junction temperature for the 813N252DI-02. Equations and example calculations are also provided.

1. Power Dissipation.

The total power dissipation for the 813N252DI-02 is the sum of the core power plus the power dissipated in the load(s). The following is the power dissipation for $V_{CCO} = 3.3V + 5\% = 3.465V$, which gives worst case results.

NOTE: Please refer to Section 3 for details on calculating power dissipated in the load.

- Power (core)_{MAX} = $V_{CCO_MAX} * I_{EE_MAX} = 3.465V * 321mA = \mathbf{1112.3mW}$
- Power (outputs)_{MAX} = **31.55mW/Loaded Output pair**
If all outputs are loaded, the total power is $2 * 31.55mW = \mathbf{63.1mW}$

Total Power_{MAX} (3.465V, with all outputs switching) = $1112.3mW + 63.1mW = \mathbf{1175.4mW}$

2. Junction Temperature.

Junction temperature, T_j , is the temperature at the junction of the bond wire and bond pad directly affects the reliability of the device. The maximum recommended junction temperature is 125°C. Limiting the internal transistor junction temperature, T_j , to 125°C ensures that the bond wire and bond pad temperature remains below 125°C.

The equation for T_j is as follows: $T_j = \theta_{JA} * Pd_total + T_A$

T_j = Junction Temperature

θ_{JA} = Junction-to-Ambient Thermal Resistance

Pd_total = Total Device Power Dissipation (example calculation is in section 1 above)

T_A = Ambient Temperature

In order to calculate junction temperature, the appropriate junction-to-ambient thermal resistance θ_{JA} must be used. Assuming no air flow and a multi-layer board, the appropriate value is 33.1°C/W per Table 6 below.

Therefore, T_j for an ambient temperature of 85°C with all outputs switching is:

$$85^\circ\text{C} + 1.175\text{W} * 33.1^\circ\text{C/W} = 123.9^\circ\text{C}. \text{ This is below the limit of } 125^\circ\text{C}.$$

This calculation is only an example. T_j will obviously vary depending on the number of loaded outputs, supply voltage, air flow and the type of board (multi-layer).

Table 6. Thermal Resistance θ_{JA} for 32 Lead VFQFN, Forced Convection

θ_{JA} by Velocity			
Meters per Second	0	1	3
Multi-Layer PCB, JEDEC Standard Test Boards	33.1°C/W	28.1°C/W	25.4°C/W

3. Calculations and Equations.

The purpose of this section is to calculate the power dissipation for the LVPECL output pair.

LVPECL output driver circuit and termination are shown in *Figure 6*.

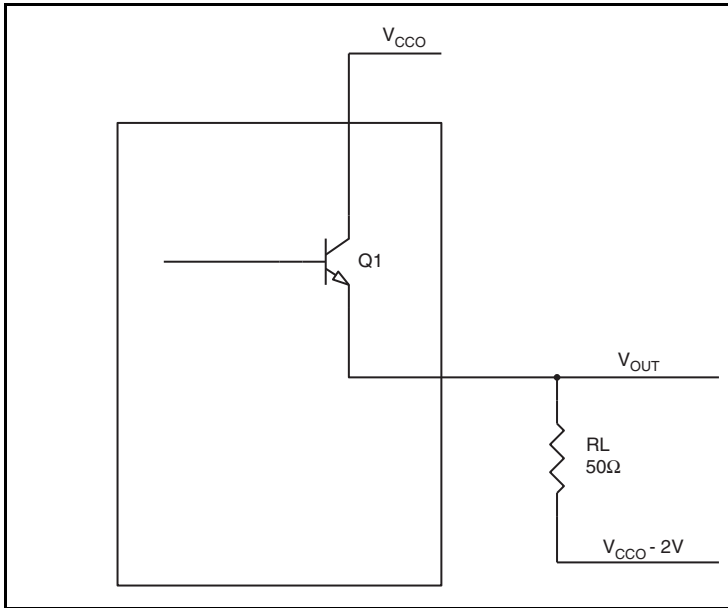

Figure 6. LVPECL Driver Circuit and Termination

o calculate worst case power dissipation into the load, use the following equations which assume a 50Ω load, and a termination voltage of $V_{CCO} - 2V$.

- For logic high, $V_{OUT} = V_{OH_MAX} = V_{CCO_MAX} - 0.75V$
 $(V_{CC_MAX} - V_{OH_MAX}) = 0.75V$
- For logic low, $V_{OUT} = V_{OL_MAX} = V_{CCO_MAX} - 1.6V$
 $(V_{CC_MAX} - V_{OL_MAX}) = 1.6V$

Pd_H is power dissipation when the output drives high.

Pd_L is the power dissipation when the output drives low.

$$Pd_H = [(V_{OH_MAX} - (V_{CCO_MAX} - 2V))/R_L] * (V_{CCO_MAX} - V_{OH_MAX}) = [(2V - (V_{CCO_MAX} - V_{OH_MAX}))/R_L] * (V_{CCO_MAX} - V_{OH_MAX}) = [(2V - 0.75V)/50\Omega] * 0.75V = 18.75mW$$

$$Pd_L = [(V_{OL_MAX} - (V_{CCO_MAX} - 2V))/R_L] * (V_{CCO_MAX} - V_{OL_MAX}) = [(2V - (V_{CCO_MAX} - V_{OL_MAX}))/R_L] * (V_{CCO_MAX} - V_{OL_MAX}) = [(2V - 1.6V)/50\Omega] * 1.6V = 12.80mW$$

Total Power Dissipation per output pair = $Pd_H + Pd_L = 31.55mW$

Reliability Information

Table 7. θ_{JA} vs. Air Flow Table for a 32 Lead VFQFN

θ_{JA} vs. Air Flow			
Meters per Second	0	1	3
Multi-Layer PCB, JEDEC Standard Test Boards	33.1°C/W	28.1°C/W	25.4°C/W

Transistor Count

The transistor count for 813N252DI-02 is: 45,491

Package Outline and Package Dimensions

Package Outline - K Suffix for 32 Lead VFQFN

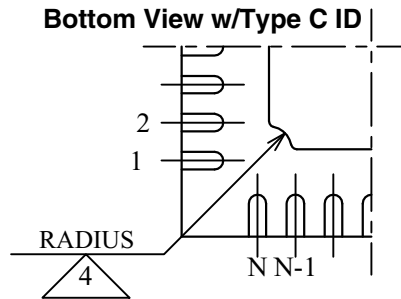
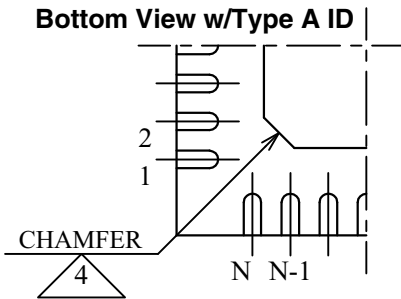
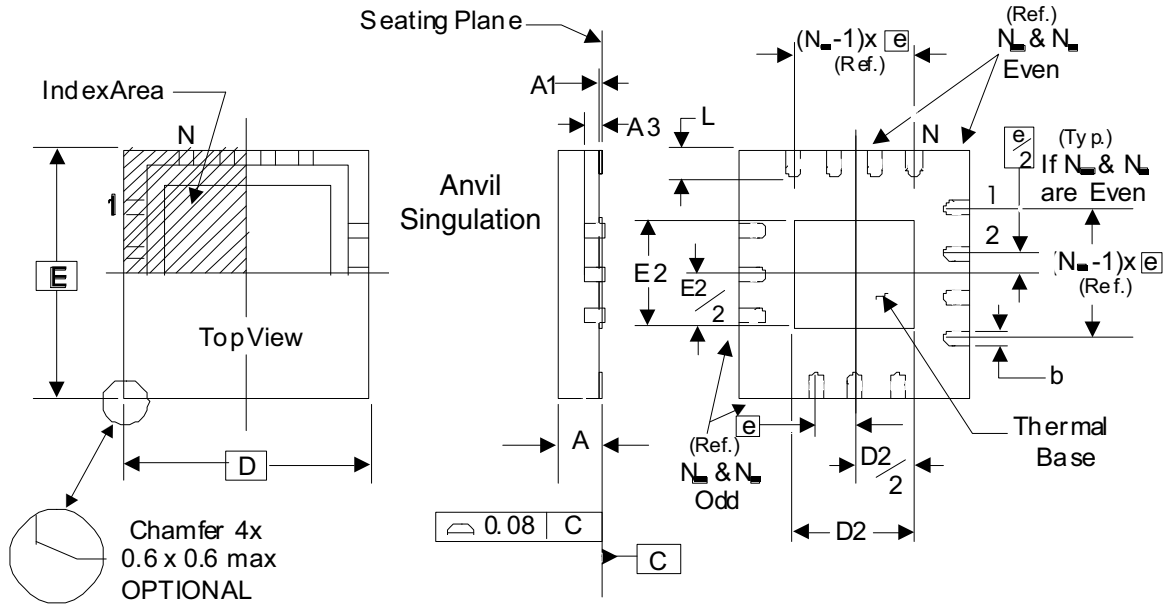

There are 2 methods of indicating pin 1 corner at the back of the VFQFN package:

1. Type A: Chamfer on the paddle (near pin 1)
2. Type C: Mouse bite on the paddle (near pin 1)

Table 8. Package Dimensions

JEDEC Variation: VHHD-2/-4 All Dimensions in Millimeters			
Symbol	Minimum	Nominal	Maximum
N	32		
A	0.80		1.00
A1	0		0.05
A3	0.25 Ref.		
b	0.18	0.25	0.30
N _D & N _E	8		
D & E	5.00 Basic		
D2 & E2	3.0		3.3
e	0.50 Basic		
L	0.30	0.40	0.50

Reference Document: JEDEC Publication 95, MO-220

NOTE: The following package mechanical drawing is a generic drawing that applies to any pin count VFQFN package. This drawing is not intended to convey the actual pin count or pin layout of this device. The pin count and pin-out are shown on the front page. The package dimensions are in Table 8.

Ordering Information

Table 9. Ordering Information

Part/Order Number	Marking	Package	Shipping Packaging	Temperature
813N252DKI-02LF	ICSN52DI02L	32 Lead VFQFN, Lead-Free	Tray	-40°C to 85°C
813N252DKI-02LFT	ICSN52DI02L	32 Lead VFQFN, Lead-Free	Tape & Reel	-40°C to 85°C

IMPORTANT NOTICE AND DISCLAIMER

RENESAS ELECTRONICS CORPORATION AND ITS SUBSIDIARIES (“RENESAS”) PROVIDES TECHNICAL SPECIFICATIONS AND RELIABILITY DATA (INCLUDING DATASHEETS), DESIGN RESOURCES (INCLUDING REFERENCE DESIGNS), APPLICATION OR OTHER DESIGN ADVICE, WEB TOOLS, SAFETY INFORMATION, AND OTHER RESOURCES “AS IS” AND WITH ALL FAULTS, AND DISCLAIMS ALL WARRANTIES, EXPRESS OR IMPLIED, INCLUDING, WITHOUT LIMITATION, ANY IMPLIED WARRANTIES OF MERCHANTABILITY, FITNESS FOR A PARTICULAR PURPOSE, OR NON-INFRINGEMENT OF THIRD-PARTY INTELLECTUAL PROPERTY RIGHTS.

These resources are intended for developers who are designing with Renesas products. You are solely responsible for (1) selecting the appropriate products for your application, (2) designing, validating, and testing your application, and (3) ensuring your application meets applicable standards, and any other safety, security, or other requirements. These resources are subject to change without notice. Renesas grants you permission to use these resources only to develop an application that uses Renesas products. Other reproduction or use of these resources is strictly prohibited. No license is granted to any other Renesas intellectual property or to any third-party intellectual property. Renesas disclaims responsibility for, and you will fully indemnify Renesas and its representatives against, any claims, damages, costs, losses, or liabilities arising from your use of these resources. Renesas' products are provided only subject to Renesas' Terms and Conditions of Sale or other applicable terms agreed to in writing. No use of any Renesas resources expands or otherwise alters any applicable warranties or warranty disclaimers for these products.

(Disclaimer Rev.1.01 Jan 2024)

Corporate Headquarters

TOYOSU FORESIA, 3-2-24 Toyosu,
Koto-ku, Tokyo 135-0061, Japan
www.renesas.com

Trademarks

Renesas and the Renesas logo are trademarks of Renesas Electronics Corporation. All trademarks and registered trademarks are the property of their respective owners.

Contact Information

For further information on a product, technology, the most up-to-date version of a document, or your nearest sales office, please visit www.renesas.com/contact-us/.

Looking for pricing, stock, or lifecycle information?

Click below to explore more details on WIN SOURCE:

 [View 813N252DKI-02LF on WIN SOURCE](#)

 [Renesas Electronics America](#) Information

Optimize Your Supply Chain with WIN SOURCE Solutions

-  Global Sourcing Solution
-  Obsolete Management
-  Cost Control Management
-  Shortage Management
-  Alternative Solution
-  Excess Inventory Management