



**THE DATASHEET OF
74HC6323AD,112**



74HC6323A; 74HCT6323A

Programmable ripple counter with oscillator; 3-state

Rev. 4 — 9 July 2018

Product data sheet

1 General description

The 74HC6323A; 74HCT6323A is an oscillator designed for quartz crystal combined with a programmable 3-state counter, a 3-state output buffer and an overriding asynchronous master reset (\overline{MR}). With the two select inputs S1 and S2 the counter can be switched in the divide-by-1, 2, 4 or 8 mode. If left floating the clock is divided by 8. The oscillator is designed to operate either in the fundamental or third overtone mode depending on the crystal and external components applied. On-chip capacitors minimize external component count for third overtone crystal applications. The oscillator may be replaced by an external clock signal at input X1. In this event the other oscillator pin (X2) must be floating. The counter advances on the negative-going transition of X1. A LOW level on \overline{MR} resets the counter, stops the oscillator and sets the output buffer in the 3-state condition. \overline{MR} can be left floating since an internal pull-up resistor will make the \overline{MR} inactive.

The X1 input has CMOS input switching levels and may be driven by a TTL output using a pull-up resistor connected to V_{CC} . Inputs include clamp diodes. This enables the use of current limiting resistors to interface inputs to voltages in excess of V_{CC} .

2 Features and benefits

- Programmable 3-stage ripple counter
- Suitable for over-tone crystal application up to 50 MHz ($V_{CC} = 5\text{ V} \pm 10\%$)
- 3-state output buffer
- Two internal capacitors
- Recommended operating range for use with third overtone crystals 3 to 6 V
- Oscillator stop function (\overline{MR})
- Input levels:
 - For 74HC6323: CMOS level
 - For 74HCT6323: TTL level
- ESD protection:
 - HBM JESD22-A114-A exceeds 2000 V
 - MM JESD22-A115-A exceeds 200 V
- Specified from $-40\text{ }^{\circ}\text{C}$ to $+85\text{ }^{\circ}\text{C}$ and from $-40\text{ }^{\circ}\text{C}$ to $+125\text{ }^{\circ}\text{C}$

3 Applications

- Control counters
- Timers
- Frequency dividers
- Time-delay circuits
- CIO (Compact Integrated Oscillator)
- Third-overtone crystal operation

4 Ordering information

Table 1. Ordering information

| Type number | Package | | Description | Version |
|-------------|-------------------|------|---|---------|
| | Temperature range | Name | | |
| 74HC6323AD | -40 °C to +125 °C | SO8 | plastic small outline package; 8 leads; body width 3.9 mm | SOT96-1 |
| 74HCT6323AD | | | | |

5 Functional diagram

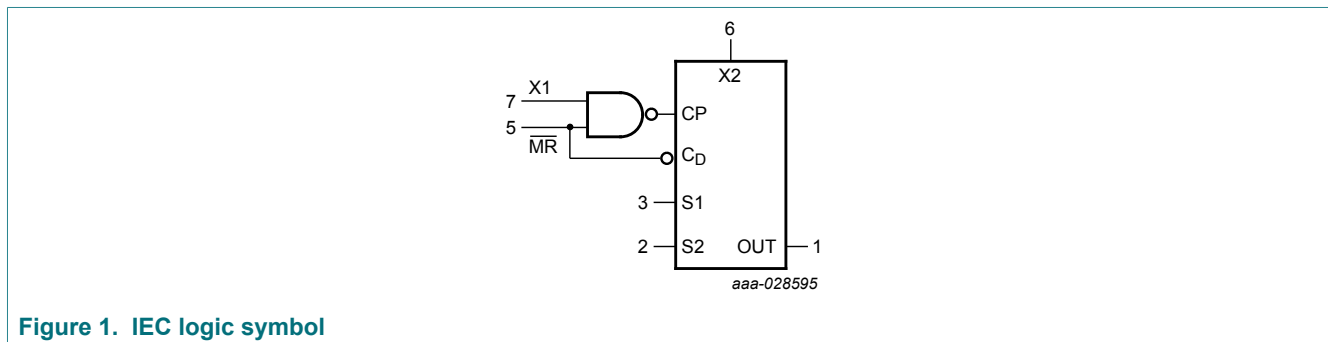

Figure 1. IEC logic symbol

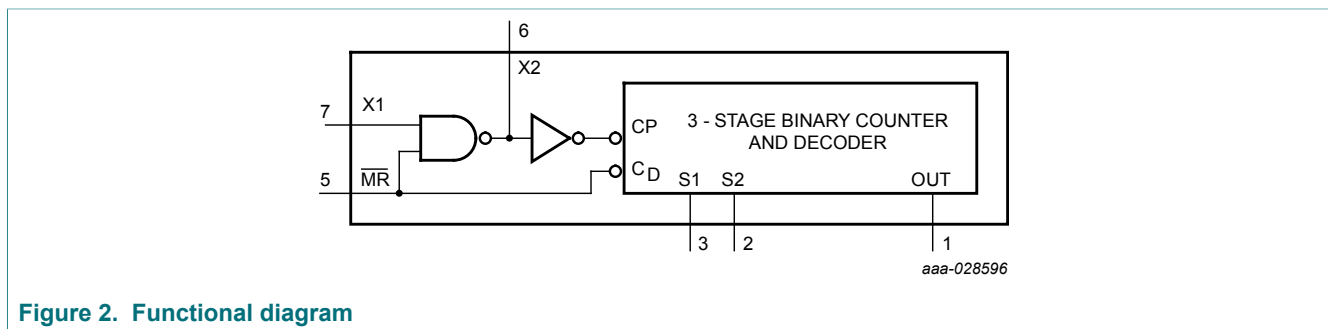
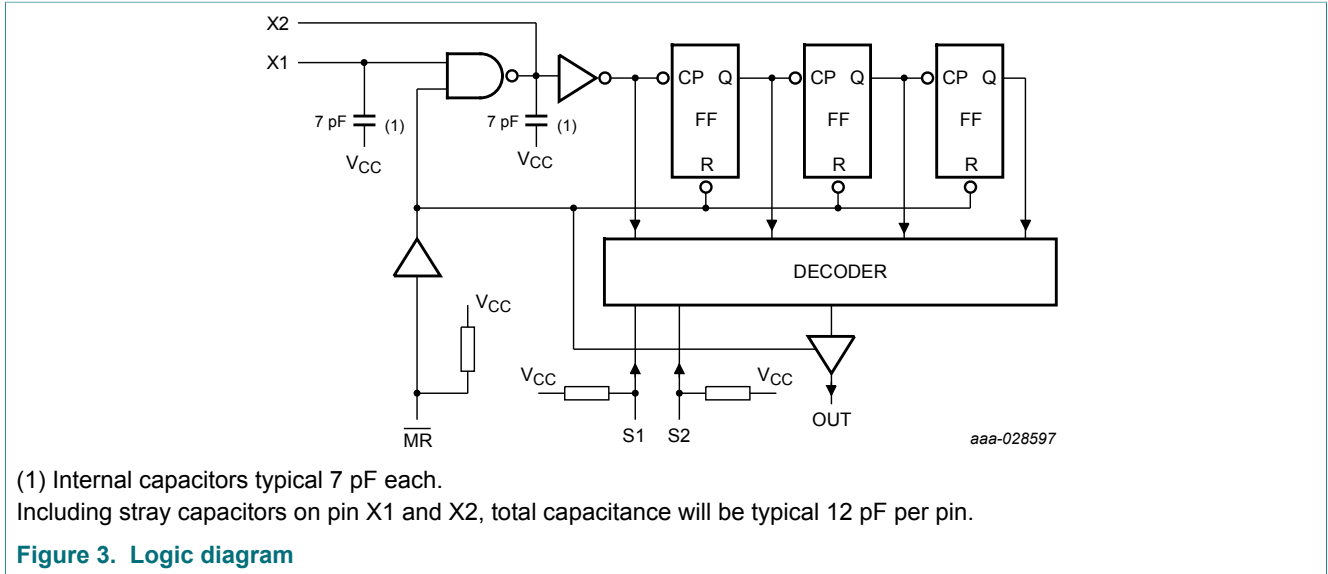
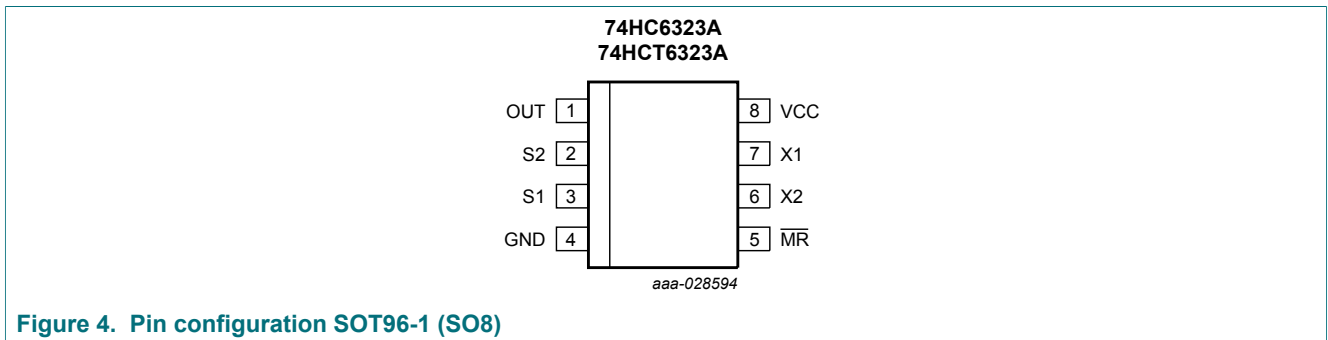

Figure 2. Functional diagram



6 Pinning information

6.1 Pinning



6.2 Pin description

Table 2. Pin description

| Symbol | Pin | Description |
|------------------------|------|---|
| OUT | 1 | counter output |
| S1, S2 | 3, 2 | mode select inputs for divide by 1, 2, 4 or 8 |
| GND | 4 | ground (0 V) |
| $\overline{\text{MR}}$ | 5 | master reset input (active LOW) |
| X2 | 6 | oscillator pin |
| X1 | 7 | clock input /oscillator pin |
| V _{CC} | 8 | supply voltage |

7 Functional description

Table 3.

| Inputs | | Outputs |
|--------|----|---------|
| S1 | S2 | OUT |
| 0 | 0 | f_i |
| 0 | 1 | $f_i/2$ |
| 1 | 0 | $f_i/4$ |
| 1 | 1 | $f_i/8$ |

8 Limiting values

Table 4. Limiting values

In accordance with the Absolute Maximum Rating System (IEC 60134). Voltages are referenced to GND (ground = 0 V).

| Symbol | Parameter | Conditions | Min | Max | Unit |
|-----------|-------------------------|---|------|----------|------|
| V_{CC} | supply voltage | | -0.5 | +7 | V |
| I_{IK} | input clamping current | $V_I < -0.5\text{ V}$ or $V_I > V_{CC} + 0.5\text{ V}$ | - | ± 20 | mA |
| I_{OK} | output clamping current | $V_O < -0.5\text{ V}$ or $V_O > V_{CC} + 0.5\text{ V}$ | - | ± 20 | mA |
| I_O | output current | OUT output; $-0.5\text{ V} < V_O < V_{CC} + 0.5\text{ V}$ | - | ± 35 | mA |
| I_{CC} | supply current | OUT output | - | 70 | mA |
| I_{GND} | ground current | OUT output | -70 | - | mA |
| T_{stg} | storage temperature | | -65 | +150 | °C |
| P_{tot} | total power dissipation | $T_{amb} = -40\text{ °C}$ to $+125\text{ °C}$ [1] | - | 500 | mW |

[1] P_{tot} derates linearly with 8 mW/K above 70 °C.

9 Recommended operating conditions

Table 5. Recommended operating conditions

Voltages are referenced to GND (ground = 0 V)

| Symbol | Parameter | Conditions | 74HC6323A | | | 74HCT6323A | | | Unit |
|---------------------|-------------------------------------|-------------------------|-----------|------|----------|------------|------|----------|------|
| | | | Min | Typ | Max | Min | Typ | Max | |
| V_{CC} | supply voltage | | 2.0 | 5.0 | 6.0 | 4.5 | 5.0 | 5.5 | V |
| V_I | input voltage | | 0 | - | V_{CC} | 0 | - | V_{CC} | V |
| V_O | output voltage | | 0 | - | V_{CC} | 0 | - | V_{CC} | V |
| T_{amb} | ambient temperature | | -40 | - | +125 | -40 | - | +125 | °C |
| $\Delta t/\Delta V$ | input transition rise and fall rate | $V_{CC} = 2.0\text{ V}$ | - | - | 625 | - | - | - | ns/V |
| | | $V_{CC} = 4.5\text{ V}$ | - | 1.67 | 139 | - | 1.67 | 139 | ns/V |
| | | $V_{CC} = 6.0\text{ V}$ | - | - | 83 | - | - | - | ns/V |

10 Static characteristics

Table 6. Static characteristics

At recommended operating conditions; voltages are referenced to GND (ground = 0 V).

| Symbol | Parameter | Conditions | 25 °C | | | -40 °C to +85 °C | | -40 °C to +125 °C | | Unit |
|--|---------------------------|---|-------|-----|------|------------------|------|-------------------|------|------|
| | | | Min | Typ | Max | Min | Max | Min | Max | |
| 74HC6323A | | | | | | | | | | |
| V _{IH} | HIGH-level input voltage | \overline{MR} , X1, S1, S2 input | | | | | | | | |
| | | V _{CC} = 2.0 V | 1.5 | 1.2 | - | 1.5 | - | 1.5 | - | V |
| | | V _{CC} = 4.5 V | 3.15 | 2.4 | - | 3.15 | - | 3.15 | - | V |
| | | V _{CC} = 6.0 V | 4.2 | 3.2 | - | 4.2 | - | 4.2 | - | V |
| V _{IL} | LOW-level input voltage | \overline{MR} , X1, S1, S2 input | | | | | | | | |
| | | V _{CC} = 2.0 V | - | 0.8 | 0.5 | - | 0.5 | - | 0.5 | V |
| | | V _{CC} = 4.5 V | - | 2.1 | 1.35 | - | 1.35 | - | 1.35 | V |
| | | V _{CC} = 6.0 V | - | 2.8 | 1.8 | - | 1.8 | - | 1.8 | V |
| V _{OH} | HIGH-level output voltage | X2 output | | | | | | | | |
| | | V _{CC} = 4.5 V; X1 = GND; \overline{MR} = V _{CC} ; I _O = -2.6 mA | 3.98 | - | - | 3.84 | - | 3.7 | - | V |
| | | V _{CC} = 6.0 V; X1 = GND; \overline{MR} = V _{CC} ; I _O = -3.3 mA | 5.48 | - | - | 5.34 | - | 5.2 | - | V |
| | | V _{CC} = 4.5 V; X1 = V _{CC} ; \overline{MR} = GND; I _O = -2.6 mA | 3.98 | - | - | 3.84 | - | 3.7 | - | V |
| | | V _{CC} = 6.0 V; X1 = V _{CC} ; \overline{MR} = GND; I _O = -3.3 mA | 5.48 | - | - | 5.34 | - | 5.2 | - | V |
| | | V _{CC} = 2.0 V; X1 = GND; \overline{MR} = V _{CC} ; I _O = -20 μA | 1.9 | 2.0 | - | 1.9 | - | 1.9 | - | V |
| | | V _{CC} = 4.5 V; X1 = GND; \overline{MR} = V _{CC} ; I _O = -20 μA | 4.4 | 4.5 | - | 4.4 | - | 4.4 | - | V |
| | | V _{CC} = 6.0 V; X1 = GND; \overline{MR} = V _{CC} ; I _O = -20 μA | 5.9 | 6.0 | - | 5.9 | - | 5.9 | - | V |
| | | V _{CC} = 2.0 V; X1 = V _{CC} ; \overline{MR} = GND; I _O = -20 μA | 1.9 | 2.0 | - | 1.9 | - | 1.9 | - | V |
| | | V _{CC} = 4.5 V; X1 = V _{CC} ; \overline{MR} = GND; I _O = -20 μA | 4.4 | 4.5 | - | 4.4 | - | 4.4 | - | V |
| V _{CC} = 6.0 V; X1 = V _{CC} ; \overline{MR} = GND; I _O = -20 μA | 5.9 | 6.0 | - | 5.9 | - | 5.9 | - | V | | |

| Symbol | Parameter | Conditions | 25 °C | | | -40 °C to +85 °C | | -40 °C to +125 °C | | Unit |
|-----------------|---------------------------|--|-------|-----|------|------------------|------|-------------------|------|------|
| | | | Min | Typ | Max | Min | Max | Min | Max | |
| V _{OH} | HIGH-level output voltage | OUT output; V _I = V _{IH} or V _{IL} | | | | | | | | |
| | | V _{CC} = 2.0 V; I _O = -20 μA | 1.9 | 2.0 | - | 1.9 | - | 1.9 | - | V |
| | | V _{CC} = 4.5 V; I _O = -20 μA | 4.4 | 4.5 | - | 4.4 | - | 4.4 | - | V |
| | | V _{CC} = 6.0 V; I _O = -20 μA | 5.9 | 6.0 | - | 5.9 | - | 5.9 | - | V |
| | | V _{CC} = 4.5 V; I _O = -6 mA | 3.98 | - | - | 3.84 | - | 3.7 | - | V |
| | | V _{CC} = 6.0 V; I _O = -7.8 mA | 5.48 | - | - | 5.34 | - | 5.2 | - | V |
| V _{OL} | LOW level output voltage | X2 output | | | | | | | | |
| | | V _{CC} = 4.5 V; X1 = V _{CC} ; \overline{MR} = V _{CC} ; I _O = 2.6 mA | - | - | 0.26 | - | 0.33 | - | 0.4 | V |
| | | V _{CC} = 6.0 V; X1 = V _{CC} ; \overline{MR} = V _{CC} ; I _O = 3.3 mA | - | - | 0.26 | - | 0.33 | - | 0.4 | V |
| | | V _{CC} = 2.0 V; X1 = V _{CC} ; \overline{MR} = V _{CC} ; I _O = 20 μA | - | 0.0 | 0.1 | - | 0.1 | - | 0.1 | V |
| | | V _{CC} = 4.5 V; X1 = V _{CC} ; \overline{MR} = V _{CC} ; I _O = 20 μA | - | 0.0 | 0.1 | - | 0.1 | - | 0.1 | V |
| | | V _{CC} = 6.0 V; X1 = V _{CC} ; \overline{MR} = V _{CC} ; I _O = 20 μA | - | 0.0 | 0.1 | - | 0.1 | - | 0.1 | V |
| V _{OL} | LOW level output voltage | OUT output; V _I = V _{IH} or V _{IL} | | | | | | | | |
| | | V _{CC} = 2.0 V; I _O = 20 μA | - | 0.0 | 0.1 | - | 0.1 | - | 0.1 | V |
| | | V _{CC} = 4.5 V; I _O = 20 μA | - | 0.0 | 0.1 | - | 0.1 | - | 0.1 | V |
| | | V _{CC} = 6.0 V; I _O = 20 μA | - | 0.0 | 0.1 | - | 0.1 | - | 0.1 | V |
| | | V _{CC} = 4.5 V; I _O = 6 mA | - | - | 0.26 | - | 0.33 | - | 0.4 | V |
| | | V _{CC} = 6.0 V; I _O = 7.8 mA | - | - | 0.26 | - | 0.33 | - | 0.4 | V |
| I _I | input leakage current | X1 input; V _{CC} = 6.0 V; \overline{MR} = V _{CC} ; S1 = V _{CC} ; S2 = V _{CC} | - | - | ±0.1 | - | ±1.0 | - | ±1.0 | μA |
| I _{pu} | pull-up current | \overline{MR} , S1 and S2 inputs; V _{CC} = 6.0 V; V _I = GND; see Figure 13 and Figure 14 . | -5 | -30 | -100 | - | - | - | - | μA |
| I _{CC} | supply current | V _{CC} = 6.0 V; V _I = V _{CC} or GND; I _O = 0 A | - | - | 8 | - | 80 | - | 160 | μA |
| C _I | input capacitance | \overline{MR} , S1 and S2 inputs | - | 3.5 | - | - | - | - | - | pF |

| Symbol | Parameter | Conditions | 25 °C | | | -40 °C to +85 °C | | -40 °C to +125 °C | | Unit |
|------------------------|---------------------------|--|-------|------|------|------------------|------|-------------------|------|------|
| | | | Min | Typ | Max | Min | Max | Min | Max | |
| 74HCT6323A | | | | | | | | | | |
| V _{IH} | HIGH-level input voltage | \overline{MR} , S1 and S2 inputs; V _{CC} = 4.5 V to 5.5 V | 2.0 | - | - | 2.0 | - | 2.0 | - | V |
| | | X1 input | | | | | | | | |
| | | V _{CC} = 4.5 V | 3.15 | - | - | 3.15 | - | 3.15 | - | V |
| | | V _{CC} = 5.5 V | 3.85 | - | - | 3.85 | - | 3.85 | - | V |
| V _{IL} | LOW-level input voltage | \overline{MR} , S1 and S2 inputs; V _{CC} = 4.5 V to 5.5 V | - | - | 0.8 | - | 0.8 | - | 0.8 | V |
| | | X1 input | | | | | | | | |
| | | V _{CC} = 4.5 V | - | - | 1.35 | - | 1.35 | - | 1.35 | V |
| | | V _{CC} = 5.5 V | - | - | 1.65 | - | 1.65 | - | 1.65 | V |
| V _{OH} | HIGH-level output voltage | X2 output; V _{CC} = 4.5 V | | | | | | | | |
| | | X1 = GND; \overline{MR} = V _{CC} ; I _O = -2.6 mA | 3.98 | - | - | 3.84 | - | 3.7 | - | V |
| | | X1 = V _{CC} ; \overline{MR} = GND; I _O = -2.6 mA | 3.98 | - | - | 3.84 | - | 3.7 | - | V |
| | | X1 = GND; \overline{MR} = V _{CC} ; I _O = -20 μA | 4.4 | 4.5 | - | 4.4 | - | 4.4 | - | V |
| | | X1 = V _{CC} ; \overline{MR} = GND; I _O = -20 μA | 4.4 | 4.5 | - | 4.4 | - | 4.4 | - | V |
| | | OUT output; V _{CC} = 4.5 V; V _I = V _{IH} or V _{IL} | | | | | | | | |
| | | I _O = -20 μA | 4.4 | 4.5 | - | 4.4 | - | 4.4 | - | V |
| I _O = -6 mA | 3.98 | - | - | 3.84 | - | 3.7 | - | V | | |
| V _{OL} | LOW-level output voltage | X2 output; V _{CC} = 4.5 V; X1 = V _{CC} ; \overline{MR} = V _{CC} | | | | | | | | |
| | | I _O = 2.6 mA | - | - | 0.26 | - | 0.33 | - | 0.4 | V |
| | | I _O = 20 μA | - | 0.0 | 0.1 | - | 0.1 | - | 0.1 | V |
| | | OUT output; V _{CC} = 4.5 V; V _I = V _{IH} or V _{IL} | | | | | | | | |
| | | I _O = 20 μA | - | 0.0 | 0.1 | - | 0.1 | - | 0.1 | V |
| I _O = 6 mA | - | - | 0.26 | - | 0.33 | - | 0.4 | V | | |
| I _I | input leakage current | X1 input; V _{CC} = 5.5 V; \overline{MR} = V _{CC} ; S1 = V _{CC} ; S2 = V _{CC} | - | - | ±0.1 | - | ±1.0 | - | ±1.0 | μA |
| I _{pu} | pull-up current | \overline{MR} , S1 and S2 inputs; V _{CC} = 5.5 V; V _I = GND; see Figure 13 and Figure 14 . | -5 | -25 | -100 | - | - | - | - | μA |

Programmable ripple counter with oscillator; 3-state

| Symbol | Parameter | Conditions | 25 °C | | | -40 °C to +85 °C | | -40 °C to +125 °C | | Unit |
|-----------------|---------------------------|--|-------|-----|-----|------------------|-----|-------------------|-----|---------------|
| | | | Min | Typ | Max | Min | Max | Min | Max | |
| I_{CC} | supply current | $V_{CC} = 5.5 \text{ V}$; $V_I = V_{CC}$ or GND; $I_O = 0 \text{ A}$ | - | - | 8 | - | 80 | - | 160 | μA |
| ΔI_{CC} | additional supply current | \overline{MR} , S1 and S2 inputs; $V_{CC} = 5.5 \text{ V}$; $V_I = V_{CC}$ or GND; other inputs at V_{CC} or GND; $I_O = 0 \text{ A}$ | - | 40 | 144 | - | 180 | - | 196 | μA |
| C_I | input capacitance | \overline{MR} , S1 and S2 inputs | - | 3.5 | - | - | - | - | - | pF |

11 Dynamic characteristics

Table 7. Dynamic characteristics

$GND = 0\text{ V}$; $C_L = 50\text{ pF}$ unless otherwise specified; for test circuit see [Figure 8](#).

| Symbol | Parameter | Conditions | 25 °C | | | -40 °C to +85 °C | | -40 °C to +125 °C | | Unit |
|-------------------------|-------------------------------------|---|-------|-----|-----|------------------|-----|-------------------|-----|------|
| | | | Min | Typ | Max | Min | Max | Min | Max | |
| 74HC6323A | | | | | | | | | | |
| t_{pd} | propagation delay | X1 to OUT divide by 1; S1 = GND; S2 = GND; see Figure 5 ^[1] | | | | | | | | |
| | | $V_{CC} = 2.0\text{ V}$ | - | 61 | 185 | - | 230 | - | 275 | ns |
| | | $V_{CC} = 4.5\text{ V}$ | - | 22 | 37 | - | 46 | - | 55 | ns |
| | | $V_{CC} = 5.0\text{ V}$; $C_L = 15\text{ pF}$ | - | 17 | - | - | - | - | - | ns |
| | | $V_{CC} = 6.0\text{ V}$ | - | 19 | 31 | - | 39 | - | 47 | ns |
| | | X1 to OUT divide by 2; S1 = GND; S2 = V_{CC} ; see Figure 5 | | | | | | | | |
| | | $V_{CC} = 2.0\text{ V}$ | - | 74 | 235 | - | 290 | - | 350 | ns |
| | | $V_{CC} = 4.5\text{ V}$ | - | 27 | 47 | - | 58 | - | 70 | ns |
| | | $V_{CC} = 6.0\text{ V}$ | - | 23 | 40 | - | 49 | - | 60 | ns |
| | | X1 to OUT divide by 4; S1 = V_{CC} ; S2 = GND; see Figure 5 | | | | | | | | |
| | | $V_{CC} = 2.0\text{ V}$ | - | 91 | 285 | - | 355 | - | 425 | ns |
| | | $V_{CC} = 4.5\text{ V}$ | - | 33 | 57 | - | 71 | - | 85 | ns |
| | | $V_{CC} = 6.0\text{ V}$ | - | 28 | 48 | - | 60 | - | 72 | ns |
| | | X1 to OUT divide by 8; S1 = V_{CC} ; S2 = V_{CC} ; see Figure 5 | | | | | | | | |
| | | $V_{CC} = 2.0\text{ V}$ | - | 105 | 335 | - | 415 | - | 500 | ns |
| $V_{CC} = 4.5\text{ V}$ | - | 38 | 67 | - | 83 | - | 100 | ns | | |
| $V_{CC} = 6.0\text{ V}$ | - | 32 | 57 | - | 71 | - | 85 | ns | | |
| t_{PZL} | OFF-state to LOW propagation delay | \overline{MR} to OUT; see Figure 6 | | | | | | | | |
| | | $V_{CC} = 2.0\text{ V}$ | - | 36 | 150 | - | 185 | - | 225 | ns |
| | | $V_{CC} = 4.5\text{ V}$ | - | 13 | 30 | - | 37 | - | 45 | ns |
| | | $V_{CC} = 6.0\text{ V}$ | - | 11 | 26 | - | 31 | - | 38 | ns |
| t_{PZH} | OFF-state to HIGH propagation delay | \overline{MR} to OUT; see Figure 6 ^[2] | | | | | | | | |
| | | $V_{CC} = 2.0\text{ V}$ | - | 61 | 200 | - | 250 | - | 300 | ns |
| | | $V_{CC} = 4.5\text{ V}$ | - | 22 | 40 | - | 50 | - | 60 | ns |
| | | $V_{CC} = 6.0\text{ V}$ | - | 19 | 34 | - | 43 | - | 51 | ns |
| t_{dis} | disable time | \overline{MR} to OUT; see Figure 6 ^[3] | | | | | | | | |
| | | $V_{CC} = 2.0\text{ V}$ | - | 75 | 150 | - | 185 | - | 225 | ns |
| | | $V_{CC} = 4.5\text{ V}$ | - | 15 | 30 | - | 37 | - | 45 | ns |
| | | $V_{CC} = 6.0\text{ V}$ | - | 13 | 26 | - | 31 | - | 38 | ns |

| Symbol | Parameter | Conditions | 25 °C | | | -40 °C to +85 °C | | -40 °C to +125 °C | | Unit |
|-------------------------|-------------------------------|---|-------|-----|-----|------------------|-----|-------------------|-----|------|
| | | | Min | Typ | Max | Min | Max | Min | Max | |
| t _t | transition time | OUT; see Figure 5 ^[4] | | | | | | | | |
| | | V _{CC} = 2.0 V | - | 14 | 60 | - | 75 | - | 90 | ns |
| | | V _{CC} = 4.5 V | - | 5 | 12 | - | 15 | - | 19 | ns |
| | | V _{CC} = 6.0 V | - | 4 | 10 | - | 13 | - | 15 | ns |
| t _w | pulse width | X1 HIGH or LOW; see Figure 5 | | | | | | | | |
| | | V _{CC} = 2.0 V | 50 | 17 | - | 60 | - | 75 | - | ns |
| | | V _{CC} = 4.5 V | 10 | 6 | - | 12 | - | 15 | - | ns |
| | | V _{CC} = 6.0 V | 9 | 5 | - | 10 | - | 13 | - | ns |
| | | MR LOW; see Figure 7 | | | | | | | | |
| | | V _{CC} = 2.0 V | 80 | 22 | - | 100 | - | 120 | - | ns |
| | | V _{CC} = 4.5 V | 16 | 8 | - | 20 | - | 24 | - | ns |
| V _{CC} = 6.0 V | 14 | 7 | - | 17 | - | 20 | - | ns | | |
| t _{rec} | recovery time | MR to X1; see Figure 7 | | | | | | | | |
| | | V _{CC} = 2.0 V | 100 | 19 | - | 125 | - | 150 | - | ns |
| | | V _{CC} = 4.5 V | 20 | 7 | - | 25 | - | 30 | - | ns |
| | | V _{CC} = 6.0 V | 17 | 6 | - | 21 | - | 26 | - | ns |
| f _{max} | maximum frequency | X1; see Figure 5 | | | | | | | | |
| | | V _{CC} = 2.0 V | 10 | 17 | - | 8 | - | 6.6 | - | MHz |
| | | V _{CC} = 4.5 V | 50 | 85 | - | 40 | - | 33 | - | MHz |
| | | V _{CC} = 5.0 V; C _L = 15 pF | - | 90 | - | - | - | - | - | MHz |
| | | V _{CC} = 6.0 V | 59 | 100 | - | 47 | - | 39 | - | MHz |
| C _{PD} | power dissipation capacitance | An external clock is applied to X1 with: t _r = t _f ≤ 6 ns, V _I = GND to V _{CC} , MR = HIGH ^[5] | | | | | | | | |
| | | divide by 1; S1 = GND; S2 = GND | - | 54 | - | - | - | - | - | pF |
| | | divide by 2; S1 = GND; S2 = V _{CC} | - | 42 | - | - | - | - | - | pF |
| | | divide by 4; S1 = V _{CC} ; S2 = GND | - | 36 | - | - | - | - | - | pF |
| | | divide by 8; S1 = V _{CC} ; S2 = V _{CC} | - | 33 | - | - | - | - | - | pF |

| Symbol | Parameter | Conditions | 25 °C | | | -40 °C to +85 °C | | -40 °C to +125 °C | | Unit |
|-------------------|-------------------------------------|---|-------|-----|-----|------------------|-----|-------------------|-----|------|
| | | | Min | Typ | Max | Min | Max | Min | Max | |
| 74HCT6323A | | | | | | | | | | |
| t _{pd} | propagation delay | X1 to OUT divide by 1; S1 = GND; S2 = GND; see Figure 5 [1] | | | | | | | | |
| | | V _{CC} = 4.5 V | - | 24 | 40 | - | 50 | - | 60 | ns |
| | | V _{CC} = 5.0 V; C _L = 15 pF | - | 17 | - | - | - | - | - | ns |
| | | X1 to OUT divide by 2; S1 = GND; S2 = V _{CC} ; see Figure 5 | | | | | | | | |
| | | V _{CC} = 4.5 V | - | 29 | 50 | - | 62 | - | 75 | ns |
| | | X1 to OUT divide by 4; S1 = V _{CC} ; S2 = GND; see Figure 5 | | | | | | | | |
| | | V _{CC} = 4.5 V | - | 35 | 60 | - | 75 | - | 90 | ns |
| t _{PZL} | OFF-state to LOW propagation delay | MR to OUT; see Figure 6 | | | | | | | | |
| | | V _{CC} = 4.5 V | - | 16 | 30 | - | 37 | - | 45 | ns |
| t _{PZH} | OFF-state to HIGH propagation delay | MR to OUT; see Figure 6 [2] | | | | | | | | |
| | | V _{CC} = 4.5 V | - | 22 | 38 | - | 47 | - | 57 | ns |
| t _{dis} | disable time | MR to OUT; see Figure 6 [3] | | | | | | | | |
| | | V _{CC} = 4.5 V | - | 21 | 35 | - | 43 | - | 52 | ns |
| t _t | transition time | OUT; see Figure 5 [4] | | | | | | | | |
| | | V _{CC} = 4.5 V | - | 5 | 12 | - | 15 | - | 19 | ns |
| t _W | pulse width | X1 HIGH or LOW; see Figure 5 | | | | | | | | |
| | | V _{CC} = 4.5 V | 10 | 6 | - | 12 | - | 15 | - | ns |
| | | MR LOW; see Figure 7 | | | | | | | | |
| t _{rec} | recovery time | MR to X1; see Figure 7 | | | | | | | | |
| | | V _{CC} = 4.5 V | 24 | 12 | - | 30 | - | 36 | - | ns |
| f _{max} | maximum frequency | X1; see Figure 5 | | | | | | | | |
| | | V _{CC} = 4.5 V | 50 | 85 | - | 40 | - | 33 | - | MHz |
| | | V _{CC} = 5.0 V; C _L = 15 pF | - | 90 | - | - | - | - | - | MHz |

| Symbol | Parameter | Conditions | 25 °C | | | -40 °C to +85 °C | | -40 °C to +125 °C | | Unit |
|-----------------|-------------------------------|---|-------|-----|-----|------------------|-----|-------------------|-----|------|
| | | | Min | Typ | Max | Min | Max | Min | Max | |
| C _{PD} | power dissipation capacitance | An external clock is applied to X1 with: $t_r = t_f \leq 6 \text{ ns}$, $V_i = \text{GND to } V_{CC}$, $\overline{\text{MR}} = \text{HIGH}$ [5] | | | | | | | | |
| | | divide by 1; S1 = GND; S2 = GND | - | 54 | - | - | - | - | - | pF |
| | | divide by 2; S1 = GND; S2 = V _{CC} | - | 42 | - | - | - | - | - | pF |
| | | divide by 4; S1 = V _{CC} ; S2 = GND | - | 36 | - | - | - | - | - | pF |
| | | divide by 8; S1 = V _{CC} ; S2 = V _{CC} | - | 33 | - | - | - | - | pF | |

- [1] t_{pd} is the same as t_{PHL} and t_{PLH} .
- [2] t_{PZH} only applicable in the divide-by-1 mode and X1 must be HIGH.
- [3] t_{dis} is the same as t_{PLZ} and t_{PHZ} .
- [4] t_i is the same as t_{THL} and t_{TLH} .
- [5] C_{PD} is used to determine the dynamic power dissipation (P_D in μW):
 $P_D = C_{PD} \times V_{CC}^2 \times f_i + (C_L \times V_{CC}^2 \times f_o) + (I_{pull-up} \times V_{CC})$ where:
 f_i = input frequency in MHz;
 f_o = output frequency in MHz;
 C_L = output load capacitance in pF;
 V_{CC} = supply voltage in V;
 $I_{pull-up}$ = pull-up currents in μA.
 $I_{pull-up}$ is the summation of -I_I (μA) of S1 and S2 inputs at the LOW state.

11.1 Waveforms and test circuit

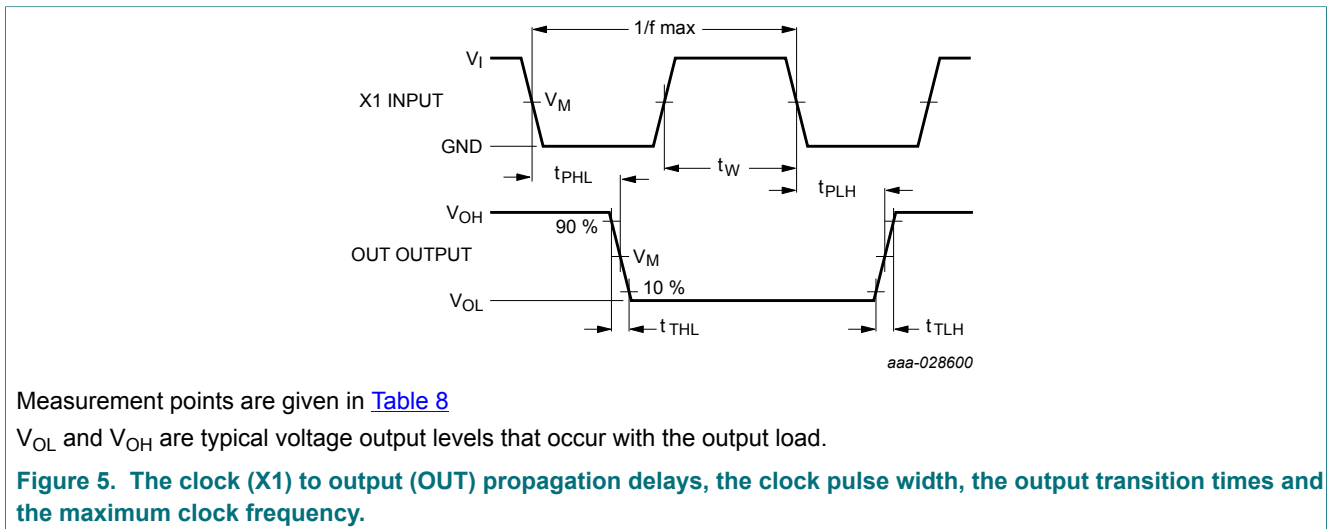

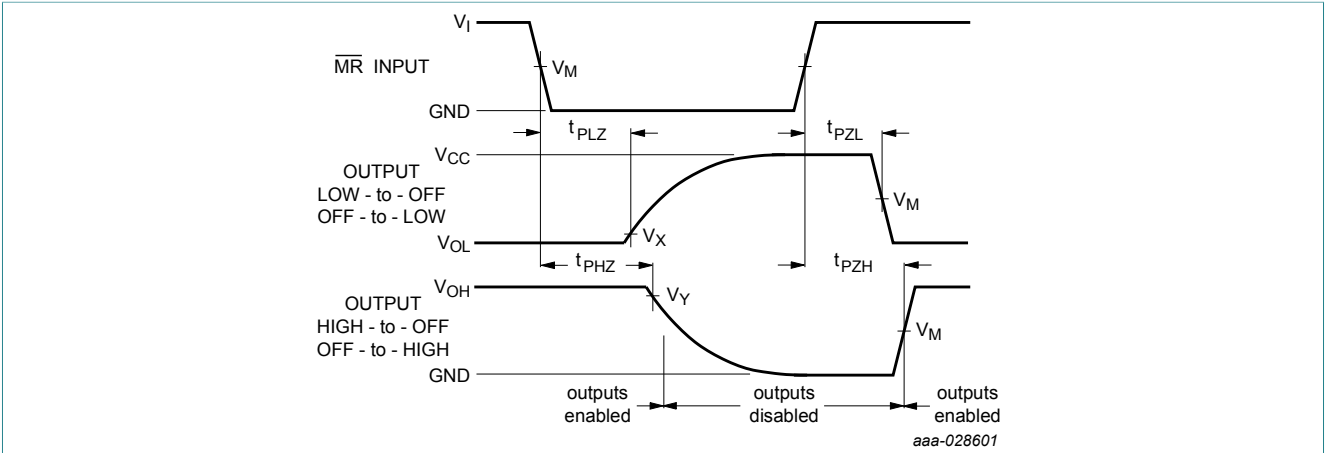

Measurement points are given in [Table 8](#)

V_{OL} and V_{OH} are typical voltage output levels that occur with the output load.

Figure 6. The input MR to output OUT, 3-state enable and disable times

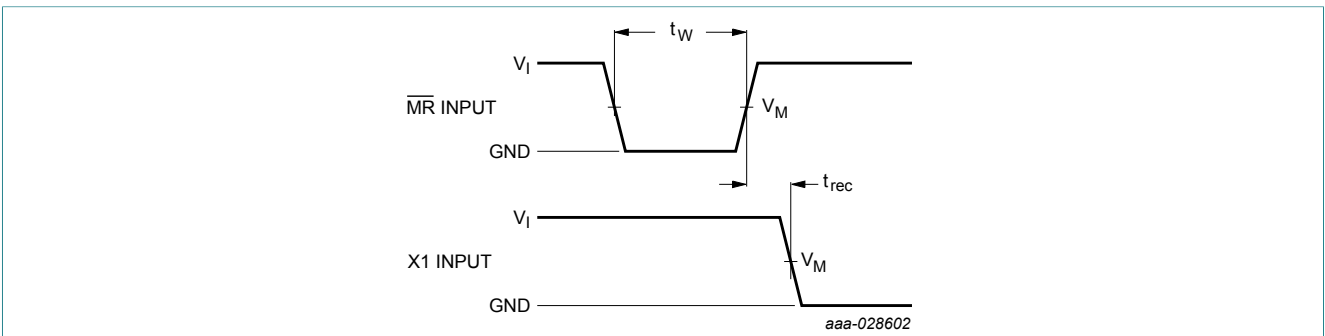

Measurement points are given in [Table 8](#)

V_{OL} and V_{OH} are typical voltage output levels that occur with the output load.

Figure 7. The MR minimum pulse width and MR to X1 recovery time.

Table 8. Measurement points

| Type | Input | | Output | | |
|------------|-----------------|---------------------|---------------------|---------------------|---------------------|
| | V_I | V_M | V_M | V_X | V_Y |
| 74HC6323A | GND to V_{CC} | $0.5 \times V_{CC}$ | $0.5 \times V_{CC}$ | $0.1 \times V_{CC}$ | $0.9 \times V_{CC}$ |
| 74HCT6323A | GND to 3 V | 1.3 V | 1.3 V | $0.1 \times V_{CC}$ | $0.9 \times V_{CC}$ |

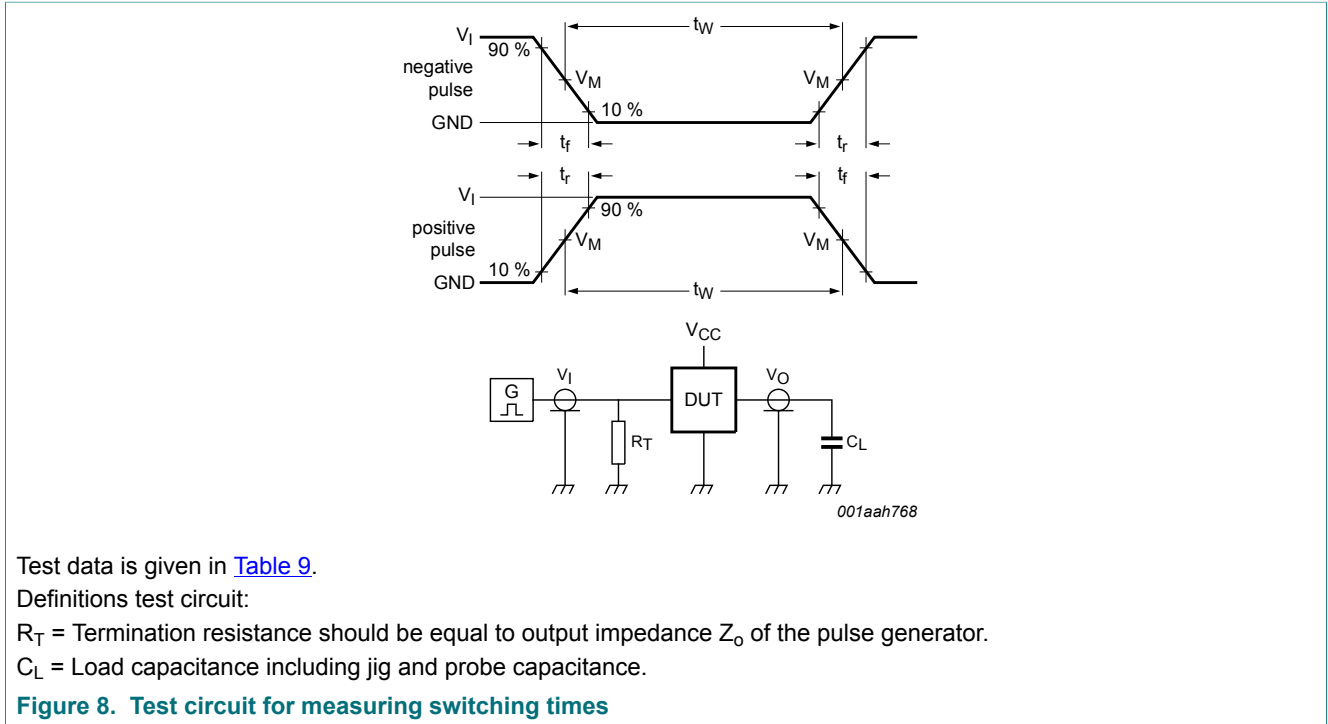

Table 9. Test data

| Type | Input | | Load |
|------------|-----------------|------------|--------------|
| | V_I | t_r, t_f | C_L |
| 74HC6323A | GND to V_{CC} | 6 ns | 15 pF, 50 pF |
| 74HCT6323A | GND to 3 V | 6 ns | 15 pF, 50 pF |

12 Application information

12.1 Typical Crystal Oscillator

In [Figure 9](#), R_2 is the power limiting resistor. For starting and maintaining oscillation a minimum transconductance is necessary, so R_2 should not be too large. A practical value for R_2 is 2.2 k Ω .

The oscillator has been designed to operate over a wide frequency spectrum, for quartz crystals operating in the fundamental mode and in the overtone mode. The circuit is a Pierce type oscillator and requires a minimum of external components. There are two on-chip capacitors, X1 and X2, of approximately 7 pF. Together with the stray and input capacitance the value becomes 12 pF for 8-pin SO packages. These values are convenient and make it possible to run the oscillator in the third overtone without external capacitors applied. If a certain frequency is chosen, the IC parameters, as forward transconductance, and the crystal parameters such as the motional resistances R_1 (fundamental), R_3 (third overtone) and R_5 (fifth overtone), are of paramount importance. Also the values of the external components as R_s (series resistance) and the crystal load capacitances play an important role. Especially in overtone mode oscillations, R_b (bias resistance) and the load capacitance values are very important.

12.2 Considerations for Fundamental Oscillator:

In the fundamental oscillator mode, the R_b has only the function of biasing the inverter stage, so that it operates as an amplifier with a phase shift of approximately 180° . The value must be high, i.e. 100 k Ω up to 10 M Ω . The load capacitors C1 and C2, must have a value that is suitable for the crystal being used. The crystal is designed for a certain frequency having a specific load capacitance. C1 can be used to trim the oscillation frequency. The series resistance reduces the total loop gain. One function of it is therefore to reduce the power dissipation in the crystal. R_s also suppresses overtone oscillations and introduces a phase shift over a broad frequency range. This is of less concern provided R_s is not too high a value.

Note: A combination of a small load capacitor value and a small series resistance, may cause a third overtone oscillation.

12.3 Considerations for Third-overtone Oscillator:

In the overtone configuration, series resistance is no longer applied. This is essential otherwise the gain for third overtone can be too small for oscillation. A simple solution to suppress the fundamental oscillation, is to spoil the crystal fundamental activity. By dramatically reducing the value of the bias resistor of the inverting stage, and applying small load capacitors, it is possible to have an insufficient phase in the total loop for fundamental oscillation. However the phase for third overtone is good. It can be explained by the $R_b \times C_1$ time constant. During oscillation the crystal with the load capacitors cause a phase shift of 180° . Because R_b is parallel with the crystal (no R_s), R_b spoils the phase for fundamental. $R_b \times C_1$ must be of a value, that it is not spoiling the phase for third overtone too much. Because third overtone is a 3 times higher frequency than the fundamental, the $R_b \times C_1$ cannot 'maintain' the higher third overtone frequency, which results in a less spoiled overtone phase.

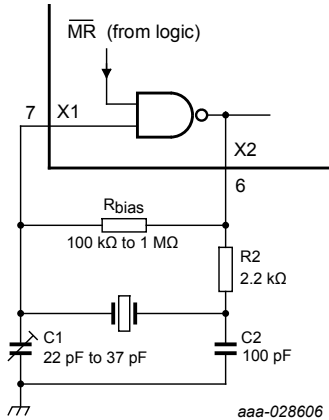

Above 5 MHz replace R2 by a capacitor of half the value of C2.

C_L at which a crystal is specified (or adjusted) equals for this application $C_1 \times C_2 / (C_1 + C_2)$

Figure 9. Typical setup for a crystal oscillator operating in the fundamental mode (1 MHz to 25 MHz)

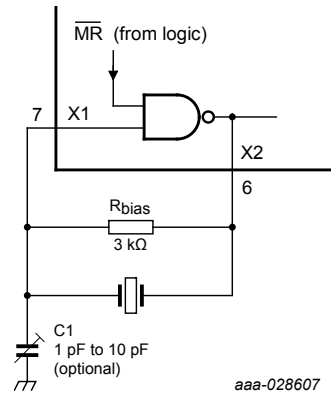

Applicable for third overtone crystals (lower damping resistance at the third harmonic frequency) at typical 50 MHz. For lower frequencies extra load capacitors must be supplied, or increase bias resistor.

Figure 10. Typical set-up for a crystal oscillator operating in the third overtone mode without the use of an inductor

Table 10. Typical application values

| Fundamental mode | | | | Third overtone mode | | |
|------------------|---------|----------|---------|---------------------|------------------------|---------|
| f (MHz) | R2 (kΩ) | C1 (pF) | C2 (pF) | f (MHz) | R _{bias} (kΩ) | C1 (pF) |
| 1 | 4.7 | 47 to 68 | | 50 | 3.0 | 4.7 |
| 10 | 2.2 | 47 to 68 | | | | |
| 25 | 1 | 33 | 33 | | | |

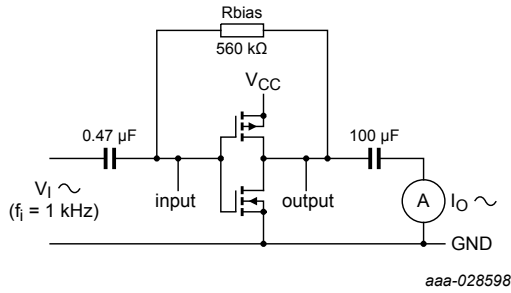

$g_{fs} = \Delta I_O / \Delta V_I$ at v_O is constant (see Figure 12) and $\overline{MR} = \text{HIGH}$.

Figure 11. Test set-up for measuring forward transconductance

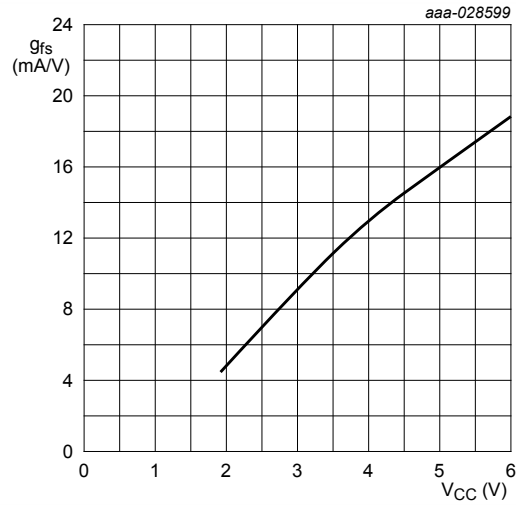

g_{fs} as a function of the supply voltage V_{CC} at $T_{amb} = 25\text{ }^\circ\text{C}$.

Figure 12. Typical forward transconductance

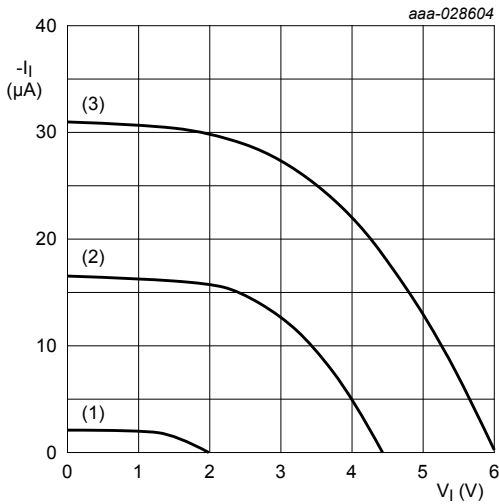

- (1) $V_{CC} = 2\text{ V}$
- (2) $V_{CC} = 4.3\text{ V}$
- (3) $V_{CC} = 6\text{ V}$

Figure 13. Typical input pull-up current as a function of the input voltage

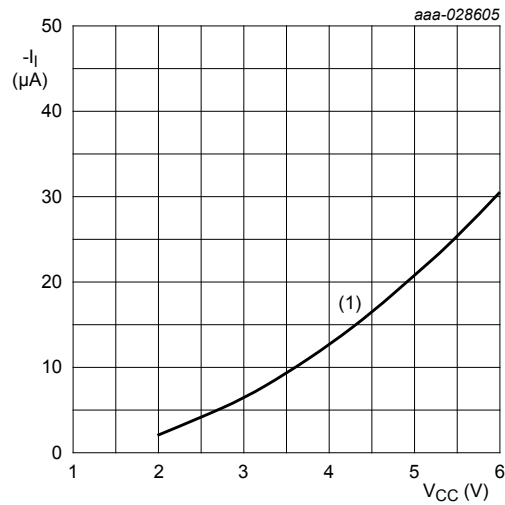

- (1) $V_I = 0\text{ V}$

Figure 14. Typical input pull-up current as a function of the supply voltage (V_{CC})

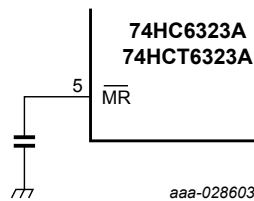

The input pull-up current is used to create a power-on delay time at \overline{MR} .

Figure 15. Power-on reset

13 Package outline

SO8: plastic small outline package; 8 leads; body width 3.9 mm

SOT96-1

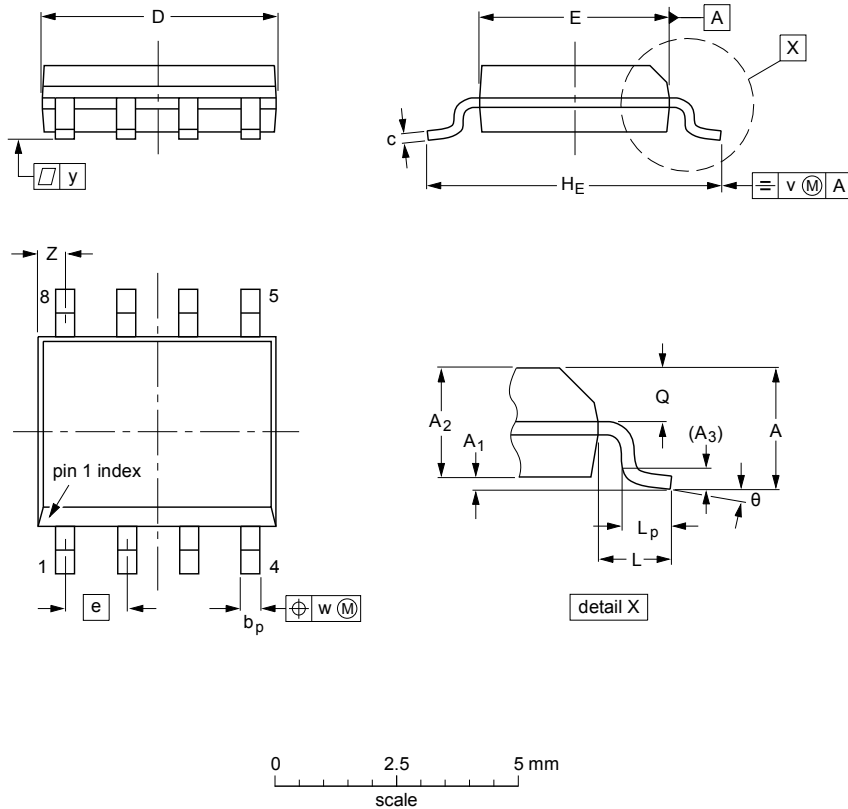

DIMENSIONS (inch dimensions are derived from the original mm dimensions)

| UNIT | A max. | A ₁ | A ₂ | A ₃ | b _p | c | D ⁽¹⁾ | E ⁽²⁾ | e | H _E | L | L _p | Q | v | w | y | Z ⁽¹⁾ | θ |
|--------|--------|----------------|----------------|----------------|----------------|------------------|------------------|------------------|------|----------------|-------|----------------|----------------|------|------|-------|------------------|----------|
| mm | 1.75 | 0.25 0.10 | 1.45 1.25 | 0.25 | 0.49 0.36 | 0.25 0.19 | 5.0 4.8 | 4.0 3.8 | 1.27 | 6.2 5.8 | 1.05 | 1.0 0.4 | 0.7 0.6 | 0.25 | 0.25 | 0.1 | 0.7 0.3 | 8° 0° |
| inches | 0.069 | 0.010 0.004 | 0.057 0.049 | 0.01 | 0.019 0.014 | 0.0100 0.0075 | 0.20 0.19 | 0.16 0.15 | 0.05 | 0.244 0.228 | 0.041 | 0.039 0.016 | 0.028 0.024 | 0.01 | 0.01 | 0.004 | 0.028 0.012 | |

Notes

1. Plastic or metal protrusions of 0.15 mm (0.006 inch) maximum per side are not included.
2. Plastic or metal protrusions of 0.25 mm (0.01 inch) maximum per side are not included.

| OUTLINE VERSION | REFERENCES | | | EUROPEAN PROJECTION | ISSUE DATE |
|-----------------|------------|--------|-------|---------------------|----------------------|
| | IEC | JEDEC | JEITA | | |
| SOT96-1 | 076E03 | MS-012 | | | 99-12-27 03-02-18 |

Figure 16. Package outline SOT96-1 (SO8)

14 Abbreviations

Table 11. Abbreviations

| Acronym | Description |
|---------|---|
| CMOS | Complementary Metal-Oxide Semiconductor |
| DUT | Device Under Test |
| ESD | ElectroStatic Discharge |
| HBM | Human Body Model |
| MM | Machine Model |
| TTL | Transistor-Transistor Logic |

15 Revision history

Table 12. Revision history

| Document ID | Release date | Data sheet status | Change notice | Supersedes |
|-------------------|---|-----------------------|---------------|-------------------|
| 74HC_HCT6323A v.4 | 20180709 | Product data sheet | - | 74HC_HCT6323A v.3 |
| Modifications: | <ul style="list-style-type: none"> The format of this data sheet has been redesigned to comply with the identity guidelines of Nexperia. Legal texts have been adapted to the new company name where appropriate. | | | |
| 74HC_HCT6323A v.3 | 19930901 | Product specification | - | 74HC_HCT6323A v.2 |
| 74HC_HCT6323A v.2 | 19901201 | Product specification | - | 74HC_HCT6323A v.1 |

16 Legal information

16.1 Data sheet status

| Document status ^{[1][2]} | Product status ^[3] | Definition |
|-----------------------------------|-------------------------------|---|
| Objective [short] data sheet | Development | This document contains data from the objective specification for product development. |
| Preliminary [short] data sheet | Qualification | This document contains data from the preliminary specification. |
| Product [short] data sheet | Production | This document contains the product specification. |

[1] Please consult the most recently issued document before initiating or completing a design.

[2] The term 'short data sheet' is explained in section "Definitions".

[3] The product status of device(s) described in this document may have changed since this document was published and may differ in case of multiple devices. The latest product status information is available on the Internet at URL <http://www.nexperia.com>.

16.2 Definitions

Draft — The document is a draft version only. The content is still under internal review and subject to formal approval, which may result in modifications or additions. Nexperia does not give any representations or warranties as to the accuracy or completeness of information included herein and shall have no liability for the consequences of use of such information.

Short data sheet — A short data sheet is an extract from a full data sheet with the same product type number(s) and title. A short data sheet is intended for quick reference only and should not be relied upon to contain detailed and full information. For detailed and full information see the relevant full data sheet, which is available on request via the local Nexperia sales office. In case of any inconsistency or conflict with the short data sheet, the full data sheet shall prevail.

Product specification — The information and data provided in a Product data sheet shall define the specification of the product as agreed between Nexperia and its customer, unless Nexperia and customer have explicitly agreed otherwise in writing. In no event however, shall an agreement be valid in which the Nexperia product is deemed to offer functions and qualities beyond those described in the Product data sheet.

16.3 Disclaimers

Limited warranty and liability — Information in this document is believed to be accurate and reliable. However, Nexperia does not give any representations or warranties, expressed or implied, as to the accuracy or completeness of such information and shall have no liability for the consequences of use of such information. Nexperia takes no responsibility for the content in this document if provided by an information source outside of Nexperia. In no event shall Nexperia be liable for any indirect, incidental, punitive, special or consequential damages (including - without limitation - lost profits, lost savings, business interruption, costs related to the removal or replacement of any products or rework charges) whether or not such damages are based on tort (including negligence), warranty, breach of contract or any other legal theory. Notwithstanding any damages that customer might incur for any reason whatsoever, Nexperia's aggregate and cumulative liability towards customer for the products described herein shall be limited in accordance with the Terms and conditions of commercial sale of Nexperia.

Right to make changes — Nexperia reserves the right to make changes to information published in this document, including without limitation specifications and product descriptions, at any time and without notice. This document supersedes and replaces all information supplied prior to the publication hereof.

Suitability for use — Nexperia products are not designed, authorized or warranted to be suitable for use in life support, life-critical or safety-critical

systems or equipment, nor in applications where failure or malfunction of an Nexperia product can reasonably be expected to result in personal injury, death or severe property or environmental damage. Nexperia and its suppliers accept no liability for inclusion and/or use of Nexperia products in such equipment or applications and therefore such inclusion and/or use is at the customer's own risk.

Applications — Applications that are described herein for any of these products are for illustrative purposes only. Nexperia makes no representation or warranty that such applications will be suitable for the specified use without further testing or modification. Customers are responsible for the design and operation of their applications and products using Nexperia products, and Nexperia accepts no liability for any assistance with applications or customer product design. It is customer's sole responsibility to determine whether the Nexperia product is suitable and fit for the customer's applications and products planned, as well as for the planned application and use of customer's third party customer(s). Customers should provide appropriate design and operating safeguards to minimize the risks associated with their applications and products. Nexperia does not accept any liability related to any default, damage, costs or problem which is based on any weakness or default in the customer's applications or products, or the application or use by customer's third party customer(s). Customer is responsible for doing all necessary testing for the customer's applications and products using Nexperia products in order to avoid a default of the applications and the products or of the application or use by customer's third party customer(s). Nexperia does not accept any liability in this respect.

Limiting values — Stress above one or more limiting values (as defined in the Absolute Maximum Ratings System of IEC 60134) will cause permanent damage to the device. Limiting values are stress ratings only and (proper) operation of the device at these or any other conditions above those given in the Recommended operating conditions section (if present) or the Characteristics sections of this document is not warranted. Constant or repeated exposure to limiting values will permanently and irreversibly affect the quality and reliability of the device.

Terms and conditions of commercial sale — Nexperia products are sold subject to the general terms and conditions of commercial sale, as published at <http://www.nexperia.com/profile/terms>, unless otherwise agreed in a valid written individual agreement. In case an individual agreement is concluded only the terms and conditions of the respective agreement shall apply. Nexperia hereby expressly objects to applying the customer's general terms and conditions with regard to the purchase of Nexperia products by customer.

No offer to sell or license — Nothing in this document may be interpreted or construed as an offer to sell products that is open for acceptance or the grant, conveyance or implication of any license under any copyrights, patents or other industrial or intellectual property rights.

Export control — This document as well as the item(s) described herein may be subject to export control regulations. Export might require a prior authorization from competent authorities.

Non-automotive qualified products — Unless this data sheet expressly states that this specific Nexperia product is automotive qualified, the product is not suitable for automotive use. It is neither qualified nor tested in accordance with automotive testing or application requirements. Nexperia accepts no liability for inclusion and/or use of non-automotive qualified products in automotive equipment or applications. In the event that customer uses the product for design-in and use in automotive applications to automotive specifications and standards, customer (a) shall use the product without Nexperia's warranty of the product for such automotive applications, use and specifications, and (b) whenever customer uses the product for automotive applications beyond Nexperia's specifications such use shall be solely at customer's own risk, and (c) customer fully indemnifies Nexperia for any liability, damages or failed product claims resulting from customer

design and use of the product for automotive applications beyond Nexperia's standard warranty and Nexperia's product specifications.

Translations — A non-English (translated) version of a document is for reference only. The English version shall prevail in case of any discrepancy between the translated and English versions.

16.4 Trademarks

Notice: All referenced brands, product names, service names and trademarks are the property of their respective owners.

Contents

| | | |
|-----------|---|-----------|
| 1 | General description | 1 |
| 2 | Features and benefits | 1 |
| 3 | Applications | 2 |
| 4 | Ordering information | 2 |
| 5 | Functional diagram | 2 |
| 6 | Pinning information | 3 |
| 6.1 | Pinning | 3 |
| 6.2 | Pin description | 3 |
| 7 | Functional description | 4 |
| 8 | Limiting values | 4 |
| 9 | Recommended operating conditions | 4 |
| 10 | Static characteristics | 5 |
| 11 | Dynamic characteristics | 9 |
| 11.1 | Waveforms and test circuit | 12 |
| 12 | Application information | 14 |
| 12.1 | Typical Crystal Oscillator | 14 |
| 12.2 | Considerations for Fundamental Oscillator: | 15 |
| 12.3 | Considerations for Third-overtone Oscillator: ... | 15 |
| 13 | Package outline | 18 |
| 14 | Abbreviations | 19 |
| 15 | Revision history | 19 |
| 16 | Legal information | 20 |

Please be aware that important notices concerning this document and the product(s) described herein, have been included in section 'Legal information'.

© Nexperia B.V. 2018.

All rights reserved.

For more information, please visit: <http://www.nexperia.com>



For sales office addresses, please send an email to: salesaddresses@nexperia.com

Date of release: 9 July 2018

Document identifier: 74HC_HCT6323A

Looking for pricing, stock, or lifecycle information?

Click below to explore more details on WIN SOURCE:

-  [View 74HC6323AD,112 on WIN SOURCE](#)
-  [Nexperia USA Inc. Information](#)

Optimize Your Supply Chain with WIN SOURCE Solutions

-  Global Sourcing Solution
-  Obsolete Management
-  Cost Control Management
-  Shortage Management
-  Alternative Solution
-  Excess Inventory Management