



**THE DATASHEET OF  
74AHCT123ABQ,115**



# 74AHC123A; 74AHCT123A

Dual retriggerable monostable multivibrator with reset

Rev. 7 — 28 February 2024

Product data sheet

## 1. General description

The 74AHC123A; 74AHCT123A is a dual retriggerable monostable multivibrator with reset. The basic output pulse width is programmed by selection of external components ( $R_{EXT}$  and  $C_{EXT}$ ). Once triggered this basic pulse width may be extended by retriggering either of the edge triggered inputs ( $nA$  or  $nB$ ). By repeating this process, the output pulse period ( $nQ = HIGH$ ,  $n\bar{Q} = LOW$ ) can be made as long as desired. Alternatively, an output delay can be terminated at any time by a LOW-going edge on input  $n\bar{RD}$ . Inputs are overvoltage tolerant. This feature allows the use of these devices as translators in mixed voltage environments.

## 2. Features and benefits

- Wide supply voltage range from 2.0 V to 5.5 V
- DC triggered from active HIGH or active LOW inputs
- Retriggerable for very long pulses up to 100 % duty factor
- Direct reset terminates output pulse
- Overvoltage tolerant inputs to 5.5 V
- All inputs have a Schmitt-trigger action
- High noise immunity
- Input levels:
  - For 74AHC123A: CMOS level
  - For 74AHCT123A: TTL level
- Latch-up performance exceeds 100 mA per JEDEC 78 Class II Level A
- ESD protection:
  - HBM: ANSI/ESDA/JEDEC JS-001 class 2 exceeds 2000 V
  - CDM: ANSI/ESDA/JEDEC JS-002 class C3 exceeds 1000 V
- Multiple package options
- Specified from -40 °C to +85 °C and from -40 °C to +125 °C

## 3. Ordering information

Table 1. Ordering information

Type number	Package			Version
	Temperature range	Name	Description	
<a href="#">74AHC123AD</a> <a href="#">74AHCT123AD</a>	-40 °C to +125 °C	SO16	plastic small outline package; 16 leads; body width 3.9 mm	<a href="#">SOT109-1</a>
<a href="#">74AHC123APW</a> <a href="#">74AHCT123APW</a>	-40 °C to +125 °C	TSSOP16	plastic thin shrink small outline package; 16 leads; body width 4.4 mm	<a href="#">SOT403-1</a>
<a href="#">74AHC123ABQ</a> <a href="#">74AHCT123ABQ</a>	-40 °C to +125 °C	DHVQFN16	plastic dual in-line compatible thermal enhanced very thin quad flat package; no leads; 16 terminals; body 2.5 × 3.5 × 0.85 mm	<a href="#">SOT763-1</a>

4. Functional diagram

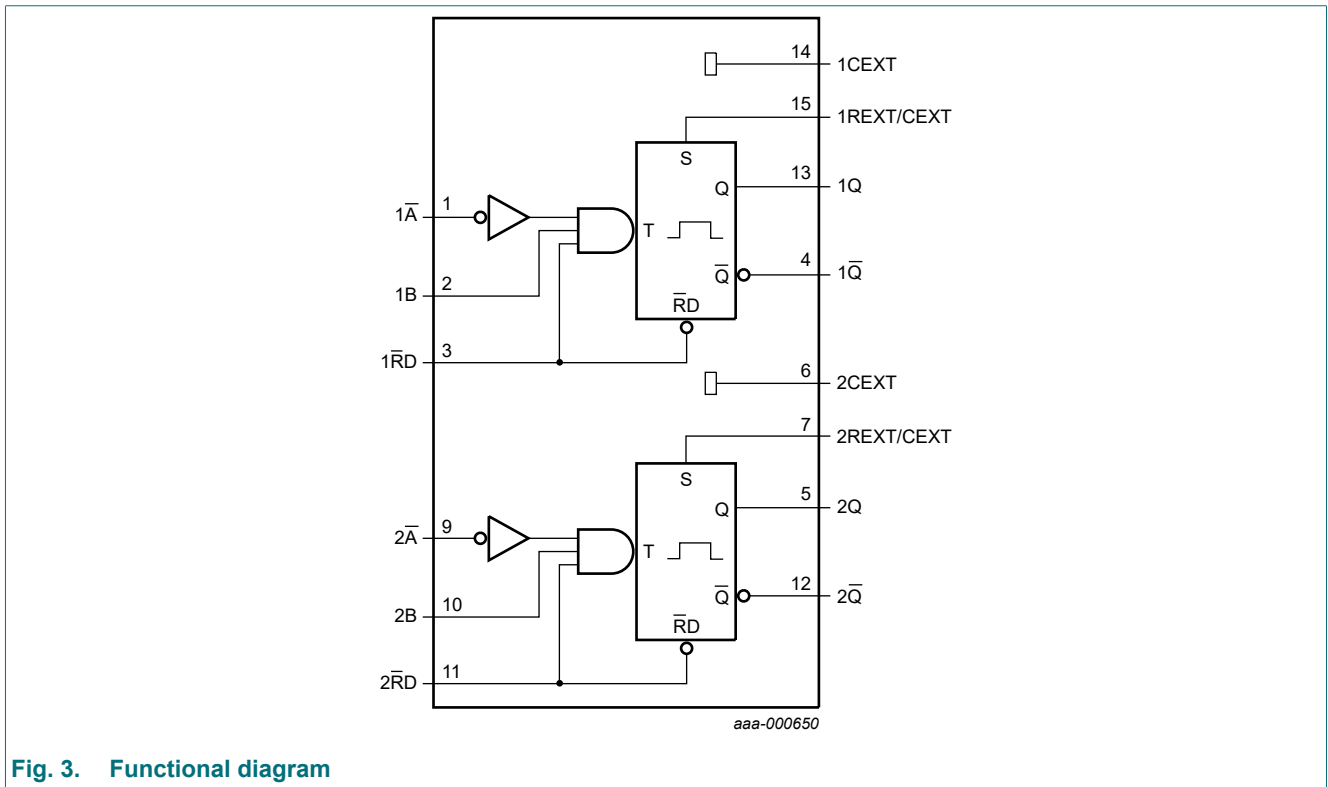
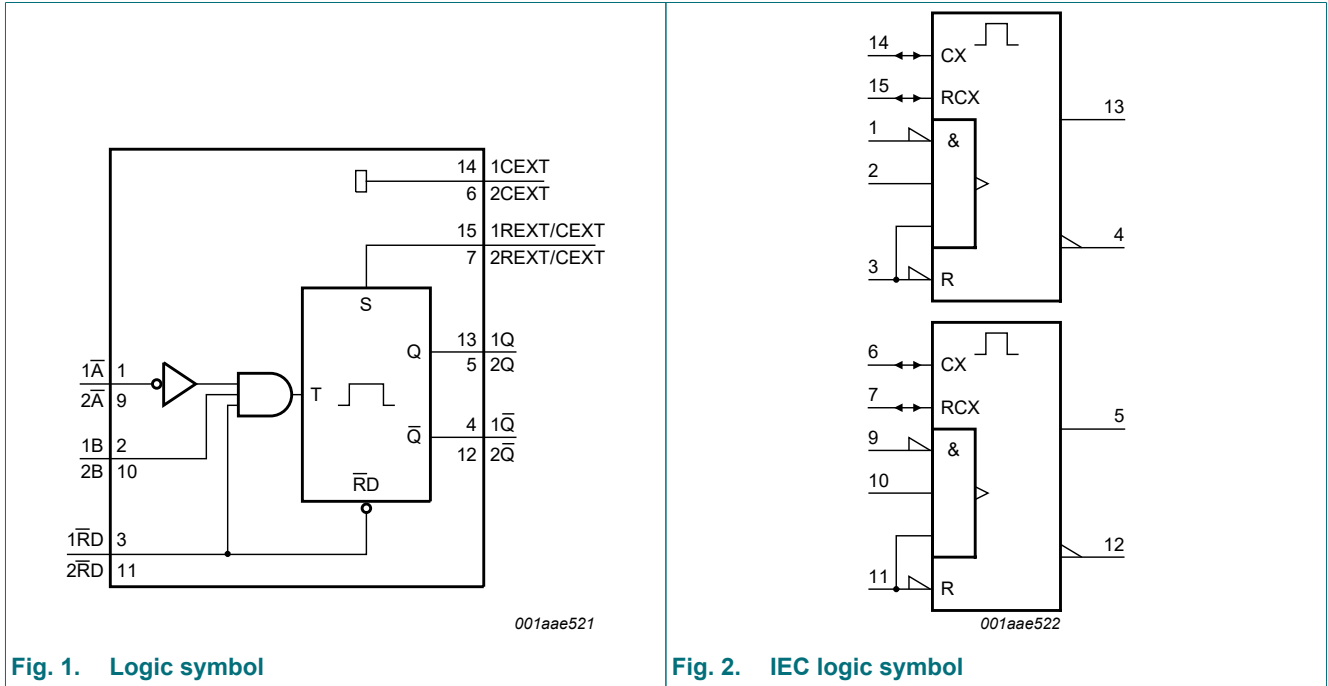

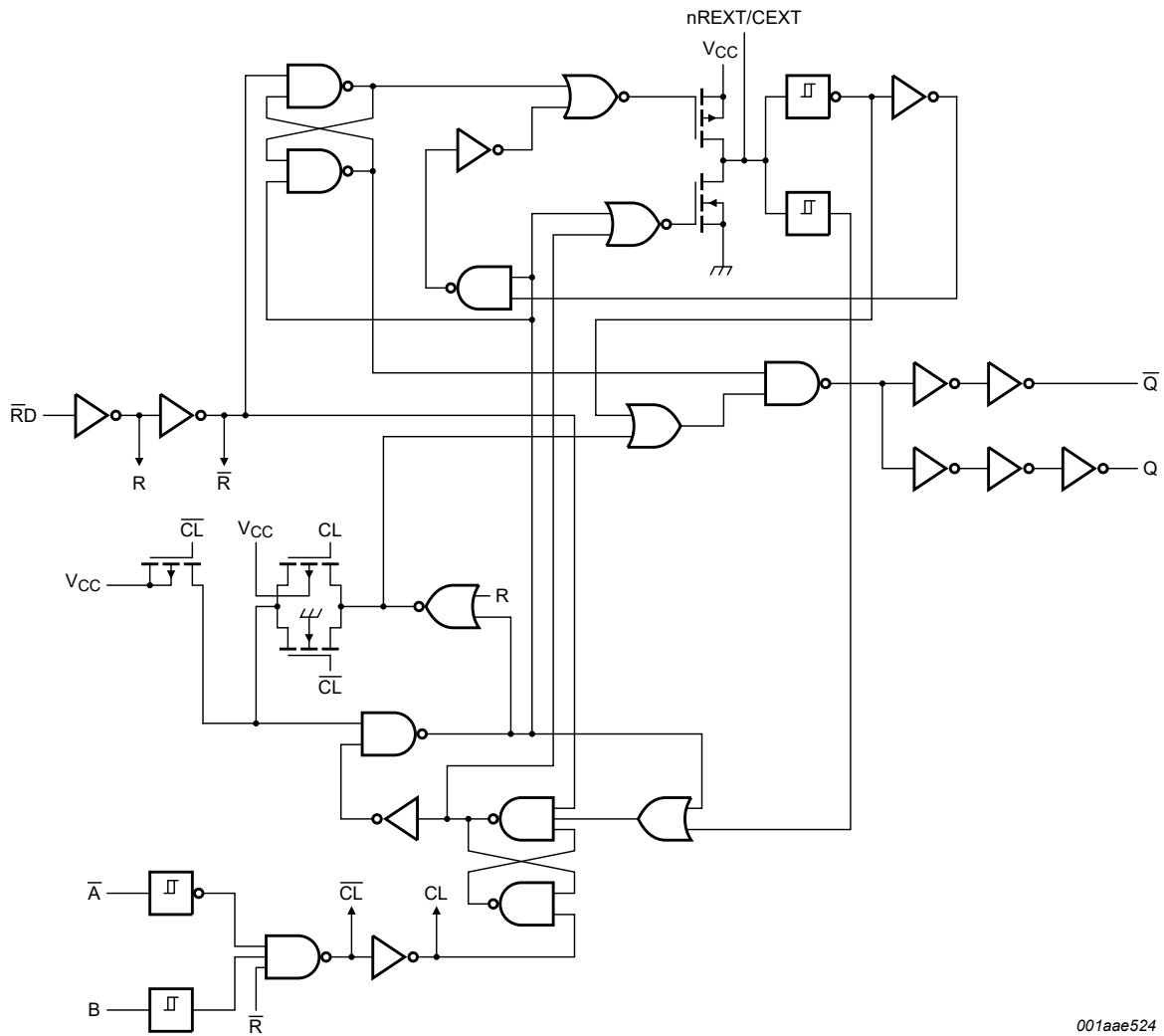

001aae524

For minimum noise generation it is recommended to ground pins 6 (2CEXT) and 14 (1CEXT) externally to pin 8 (GND).

Fig. 4. Functional diagram

5. Pinning information

5.1. Pinning

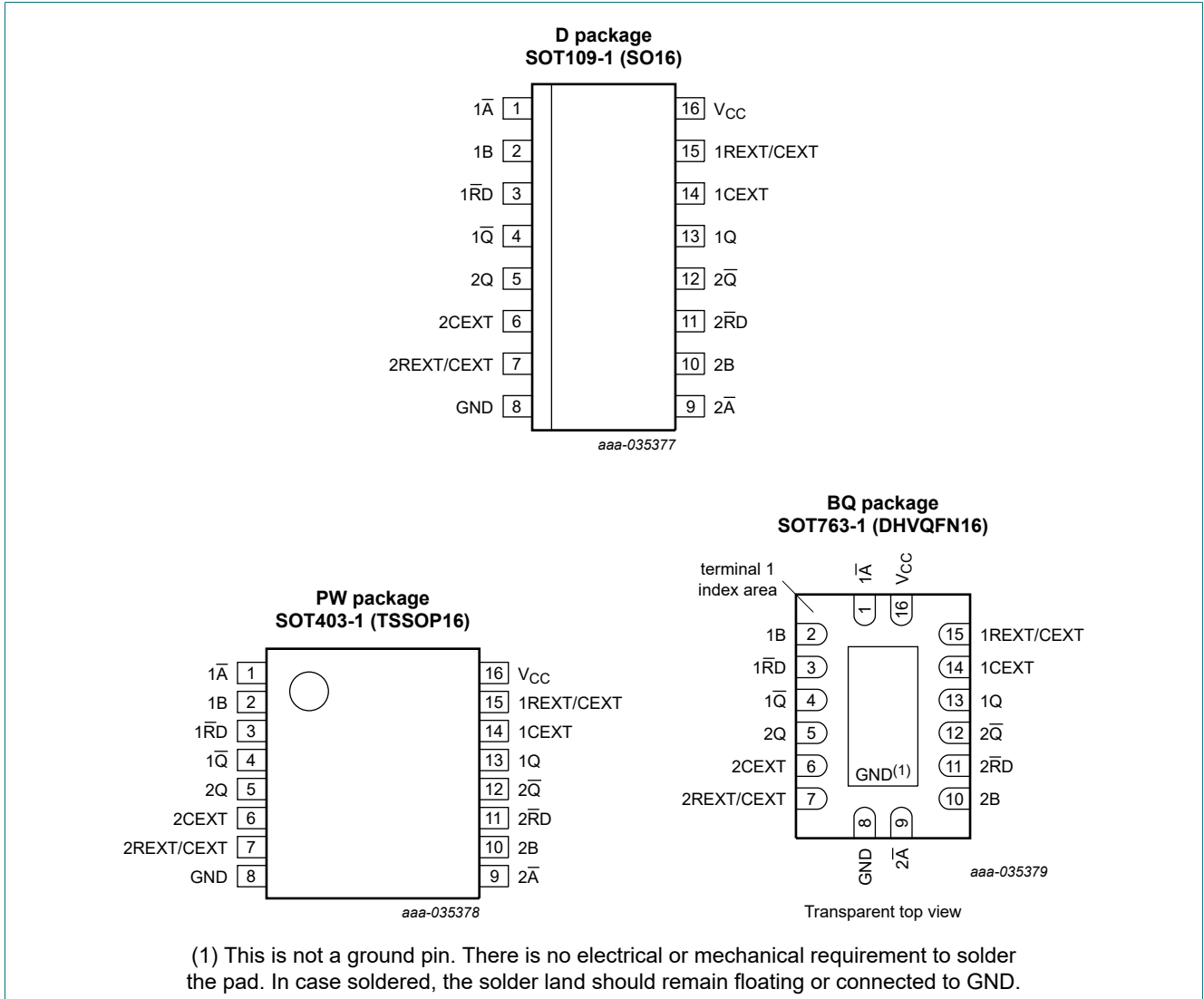

## 5.2. Pin description

Table 2. Pin description

Symbol	Pin	Description
1 $\bar{A}$	1	negative-edge triggered input 1
1B	2	positive-edge triggered input 1
1 $\bar{R}D$	3	direct reset LOW and positive-edge triggered input 1
1 $\bar{Q}$	4	active LOW output 1
2Q	5	active HIGH output 2
2CEXT	6	external capacitor connection 2
2REXT/CEXT	7	external resistor and capacitor connection 2
GND	8	ground (0 V)
2 $\bar{A}$	9	negative-edge triggered input 2
2B	10	positive-edge triggered input 2
2 $\bar{R}D$	11	direct reset LOW and positive-edge triggered input 2
2 $\bar{Q}$	12	active LOW output 2
1Q	13	active HIGH output 1
1CEXT	14	external capacitor connection 1
1REXT/CEXT	15	external resistor and capacitor connection 1
V <sub>CC</sub>	16	supply voltage

## 6. Functional description

Table 3. Function table







H = HIGH voltage level; L = LOW voltage level; X = don't care;

↑ = LOW-to-HIGH transition;

↓ = HIGH-to-LOW transition;

 = one HIGH level output pulse;

 = one LOW level output pulse.

Input			Output	
n $\bar{R}D$	n $\bar{A}$	nB	nQ	n $\bar{Q}$
L	X	X	L	H
X	H	X	L [1]	H [1]
X	X	L	L [1]	H [1]
H	L	↑		
H	↓	H		
↑	L	H		

[1] If the monostable multivibrator was triggered before this condition was established, the pulse will continue as programmed.

## 7. Limiting values

**Table 4. Limiting values**

In accordance with the Absolute Maximum Rating System (IEC 60134). Voltages are referenced to GND (ground = 0 V).

Symbol	Parameter	Conditions	Min	Max	Unit
$V_{CC}$	supply voltage		-0.5	+7.0	V
$V_I$	input voltage		-0.5	+7.0	V
$I_{IK}$	input clamping current	$V_I < -0.5$ V [1]	-20	-	mA
$I_{OK}$	output clamping current	$V_O < -0.5$ V or $V_O > V_{CC} + 0.5$ V [1]	-	$\pm 20$	mA
$I_O$	output current	$V_O = -0.5$ V to $(V_{CC} + 0.5$ V)	-	$\pm 25$	mA
$I_{CC}$	supply current		-	75	mA
$I_{GND}$	ground current		-75	-	mA
$T_{stg}$	storage temperature		-65	+150	°C
$P_{tot}$	total power dissipation	$T_{amb} = -40$ °C to $+125$ °C [2]	-	500	mW

[1] The input and output voltage ratings may be exceeded if the input and output current ratings are observed.

[2] For SOT109-1 (SO16) package:  $P_{tot}$  derates linearly with 12.4 mW/K above 110 °C.  
 For SOT403-1 (TSSOP16) package:  $P_{tot}$  derates linearly with 8.5 mW/K above 91 °C.  
 For SOT763-1 (DHVQFN16) package:  $P_{tot}$  derates linearly with 11.2 mW/K above 106 °C.

## 8. Recommended operating conditions

**Table 5. Recommended operating conditions**

Voltages are referenced to GND (ground = 0 V).

Symbol	Parameter	Conditions	74AHC123A			74AHCT123A			Unit
			Min	Typ	Max	Min	Typ	Max	
$V_{CC}$	supply voltage		2.0	5.0	5.5	4.5	5.0	5.5	V
$V_I$	input voltage		0	-	5.5	0	-	5.5	V
$V_O$	output voltage		0	-	$V_{CC}$	0	-	$V_{CC}$	V
$T_{amb}$	ambient temperature		-40	+25	+125	-40	+25	+125	°C
$\Delta t/\Delta V$	input transition rise and fall rate	$V_{CC} = 3.3$ V $\pm$ 0.3 V	-	-	100	-	-	-	ns/V
		$V_{CC} = 5.0$ V $\pm$ 0.5 V	-	-	20	-	-	20	ns/V

## 9. Static characteristics

**Table 6. Static characteristics**

Voltages are referenced to GND (ground = 0 V).

Symbol	Parameter	Conditions	25 °C			-40 °C to +85 °C		-40 °C to +125 °C		Unit
			Min	Typ	Max	Min	Max	Min	Max	
<b>74AHC123A</b>										
V <sub>IH</sub>	HIGH-level input voltage	V <sub>CC</sub> = 2.0 V	1.5	-	-	1.5	-	1.5	-	V
		V <sub>CC</sub> = 3.0 V	2.1	-	-	2.1	-	2.1	-	V
		V <sub>CC</sub> = 5.5 V	3.85	-	-	3.85	-	3.85	-	V
V <sub>IL</sub>	LOW-level input voltage	V <sub>CC</sub> = 2.0 V	-	-	0.5	-	0.5	-	0.5	V
		V <sub>CC</sub> = 3.0 V	-	-	0.9	-	0.9	-	0.9	V
		V <sub>CC</sub> = 5.5 V	-	-	1.65	-	1.65	-	1.65	V
V <sub>OH</sub>	HIGH-level output voltage	V <sub>I</sub> = V <sub>IH</sub> or V <sub>IL</sub>								
		I <sub>O</sub> = -50 μA; V <sub>CC</sub> = 2.0 V	1.9	2.0	-	1.9	-	1.9	-	V
		I <sub>O</sub> = -50 μA; V <sub>CC</sub> = 3.0 V	2.9	3.0	-	2.9	-	2.9	-	V
		I <sub>O</sub> = -50 μA; V <sub>CC</sub> = 4.5 V	4.4	4.5	-	4.4	-	4.4	-	V
		I <sub>O</sub> = -4.0 mA; V <sub>CC</sub> = 3.0 V	2.58	-	-	2.48	-	2.40	-	V
I <sub>O</sub> = -8.0 mA; V <sub>CC</sub> = 4.5 V	3.94	-	-	3.8	-	3.70	-	V		
V <sub>OL</sub>	LOW-level output voltage	V <sub>I</sub> = V <sub>IH</sub> or V <sub>IL</sub>								
		I <sub>O</sub> = 50 μA; V <sub>CC</sub> = 2.0 V	-	0	0.1	-	0.1	-	0.1	V
		I <sub>O</sub> = 50 μA; V <sub>CC</sub> = 3.0 V	-	0	0.1	-	0.1	-	0.1	V
		I <sub>O</sub> = 50 μA; V <sub>CC</sub> = 4.5 V	-	0	0.1	-	0.1	-	0.1	V
		I <sub>O</sub> = 4.0 mA; V <sub>CC</sub> = 3.0 V	-	-	0.36	-	0.44	-	0.55	V
I <sub>O</sub> = 8.0 mA; V <sub>CC</sub> = 4.5 V	-	-	0.36	-	0.44	-	0.55	V		
I <sub>I</sub>	input leakage current	V <sub>I</sub> = 5.5 V or GND; V <sub>CC</sub> = 0 V to 5.5 V								
		nREXT/CEXT [1]	-	-	±0.25	-	±2.5	-	±10.0	μA
		pins nA, nB, nRD	-	-	±0.1	-	±1.0	-	±2.0	μA
I <sub>CC</sub>	supply current	V <sub>I</sub> = V <sub>CC</sub> or GND; I <sub>O</sub> = 0 A; V <sub>CC</sub> = 5.5 V	-	-	4.0	-	40	-	80	μA
		active state (per circuit); V <sub>I</sub> = V <sub>CC</sub> or GND [1]								
		V <sub>CC</sub> = 3.0 V	-	160	250	-	280	-	280	μA
		V <sub>CC</sub> = 4.5 V	-	380	500	-	650	-	650	μA
		V <sub>CC</sub> = 5.5 V	-	560	750	-	975	-	975	μA
C <sub>I</sub>	input capacitance		-	5.0	10	-	10	-	10	pF
C <sub>O</sub>	output capacitance		-	4.0	-	-	-	-	-	pF

## Dual retriggerable monostable multivibrator with reset

Symbol	Parameter	Conditions	25 °C			-40 °C to +85 °C		-40 °C to +125 °C		Unit
			Min	Typ	Max	Min	Max	Min	Max	
<b>74AHCT123A</b>										
V <sub>IH</sub>	HIGH-level input voltage	V <sub>CC</sub> = 4.5 V to 5.5 V	2.0	-	-	2.0	-	2.0	-	V
V <sub>IL</sub>	LOW-level input voltage	V <sub>CC</sub> = 4.5 V to 5.5 V	-	-	0.8	-	0.8	-	0.8	V
V <sub>OH</sub>	HIGH-level output voltage	V <sub>I</sub> = V <sub>IH</sub> or V <sub>IL</sub> ; V <sub>CC</sub> = 4.5 V								
		I <sub>O</sub> = -50 µA	4.4	4.5	-	4.4	-	4.4	-	V
		I <sub>O</sub> = -8.0 mA	3.94	-	-	3.8	-	3.70	-	V
V <sub>OL</sub>	LOW-level output voltage	V <sub>I</sub> = V <sub>IH</sub> or V <sub>IL</sub> ; V <sub>CC</sub> = 4.5 V								
		I <sub>O</sub> = 50 µA	-	0	0.1	-	0.1	-	0.1	V
		I <sub>O</sub> = 8.0 mA	-	-	0.36	-	0.44	-	0.55	V
I <sub>I</sub>	input leakage current	nREXT/CEXT; V <sub>I</sub> = 5.5 V or GND; V <sub>CC</sub> = 0 V to 5.5 V [1]	-	-	±0.25	-	±2.5	-	±10.0	µA
		pins n $\bar{A}$ , nB, n $\bar{R}$ D; V <sub>I</sub> = V <sub>CC</sub> or GND; V <sub>CC</sub> = 5.5 V	-	-	±0.1	-	±1.0	-	±2.0	µA
I <sub>CC</sub>	supply current	V <sub>I</sub> = V <sub>CC</sub> or GND; I <sub>O</sub> = 0 A; V <sub>CC</sub> = 5.5 V	-	-	4.0	-	40	-	80	µA
		active state (per circuit); V <sub>I</sub> = V <sub>CC</sub> or GND [1]								
		V <sub>CC</sub> = 4.5 V	-	380	500	-	650	-	650	µA
		V <sub>CC</sub> = 5.5 V	-	560	750	-	975	-	975	µA
C <sub>I</sub>	input capacitance		-	3	10	-	10	-	10	pF
C <sub>O</sub>	output capacitance		-	4.0	-	-	-	-	-	pF

[1] Voltage on nREXT/CEXT = 0.5 × V<sub>CC</sub> and pin nREXT/CEXT in OFF-state during test.

### 10. Dynamic characteristics

Table 7. Dynamic characteristics

GND = 0 V; For test circuit see Fig. 10.

Symbol	Parameter	Conditions	25 °C			-40 °C to +85 °C		-40 °C to +125 °C		Unit
			Min	Typ[1]	Max	Min	Max	Min	Max	
<b>74AHC123A</b>										
t <sub>pd</sub>	propagation delay	n $\bar{A}$ and nB to nQ and n $\bar{Q}$ ; see Fig. 5 [2]								
		V <sub>CC</sub> = 3.0 V to 3.6 V; C <sub>L</sub> = 15 pF	-	7.4	20.6	1.0	24.0	1.0	26.0	ns
		V <sub>CC</sub> = 3.0 V to 3.6 V; C <sub>L</sub> = 50 pF	-	10.5	24.1	1.0	27.5	1.0	30.0	ns
		V <sub>CC</sub> = 4.5 V to 5.5 V; C <sub>L</sub> = 15 pF	-	5.1	12.0	1.0	14.0	1.0	15.5	ns
		V <sub>CC</sub> = 4.5 V to 5.5 V; C <sub>L</sub> = 50 pF	-	7.3	14.0	1.0	16.0	1.0	17.5	ns
		n $\bar{R}D$ to nQ and n $\bar{Q}$ ; see Fig. 5 [2]								
		V <sub>CC</sub> = 3.0 V to 3.6 V; C <sub>L</sub> = 15 pF	-	8.2	22.4	1.0	26.0	1.0	28.0	ns
		V <sub>CC</sub> = 3.0 V to 3.6 V; C <sub>L</sub> = 50 pF	-	11.7	25.9	1.0	29.5	1.0	32.0	ns
		V <sub>CC</sub> = 4.5 V to 5.5 V; C <sub>L</sub> = 15 pF	-	5.6	12.9	1.0	15.0	1.0	16.5	ns
		V <sub>CC</sub> = 4.5 V to 5.5 V; C <sub>L</sub> = 50 pF	-	8.1	14.9	1.0	17.0	1.0	19.0	ns
		n $\bar{R}D$ to nQ and n $\bar{Q}$ (reset); see Fig. 5 [2]								
		V <sub>CC</sub> = 3.0 V to 3.6 V; C <sub>L</sub> = 15 pF	-	6.4	15.8	1.0	18.5	1.0	20.0	ns
		V <sub>CC</sub> = 3.0 V to 3.6 V; C <sub>L</sub> = 50 pF	-	9.2	19.3	1.0	22.0	1.0	24.5	ns
		V <sub>CC</sub> = 4.5 V to 5.5 V; C <sub>L</sub> = 15 pF	-	4.4	9.4	1.0	11.0	1.0	12.0	ns
V <sub>CC</sub> = 4.5 V to 5.5 V; C <sub>L</sub> = 50 pF	-	6.3	11.4	1.0	13.0	1.0	14.5	ns		
t <sub>w</sub>	pulse width	inputs; n $\bar{A}$ = LOW; see Fig. 5								
		V <sub>CC</sub> = 3.0 V to 3.6 V	5.0	-	-	5.0	-	5.0	-	ns
		V <sub>CC</sub> = 4.5 V to 5.5 V	5.0	-	-	5.0	-	5.0	-	ns
		inputs; nB = HIGH; see Fig. 5								
		V <sub>CC</sub> = 3.0 V to 3.6 V	5.0	-	-	5.0	-	5.0	-	ns
		V <sub>CC</sub> = 4.5 V to 5.5 V	5.0	-	-	5.0	-	5.0	-	ns
		inputs; n $\bar{R}D$ = LOW; see Fig. 5								
		V <sub>CC</sub> = 3.0 V to 3.6 V	5.0	-	-	5.0	-	5.0	-	ns
		V <sub>CC</sub> = 4.5 V to 5.5 V	5.0	-	-	5.0	-	5.0	-	ns
		outputs; n $\bar{Q}$ = LOW and nQ = HIGH; C <sub>L</sub> = 50 pF; see Fig. 5, Fig. 6, Fig. 7 and Fig. 8 [3]								
		C <sub>EXT</sub> = 28 pF; R <sub>EXT</sub> = 2 k $\Omega$								
		V <sub>CC</sub> = 3.0 V to 3.6 V	-	115	240	-	300	-	300	ns
		V <sub>CC</sub> = 4.5 V to 5.5 V	-	100	200	-	240	-	240	ns
		C <sub>EXT</sub> = 0.01 $\mu$ F; R <sub>EXT</sub> = 10 k $\Omega$								
		V <sub>CC</sub> = 3.0 V to 3.6 V	90	100	110	90	110	85	115	$\mu$ s
		V <sub>CC</sub> = 4.5 V to 5.5 V	90	100	110	90	110	85	115	$\mu$ s
		C <sub>EXT</sub> = 0.1 $\mu$ F; R <sub>EXT</sub> = 10 k $\Omega$ ;								
		V <sub>CC</sub> = 3.0 V to 3.6 V	0.9	1	1.1	0.9	1.1	0.85	1.15	ms
V <sub>CC</sub> = 4.5 V to 5.5 V	0.9	1	1.1	0.9	1.1	0.85	1.15	ms		

Dual retriggerable monostable multivibrator with reset

Symbol	Parameter	Conditions	25 °C			-40 °C to +85 °C		-40 °C to +125 °C		Unit
			Min	Typ[1]	Max	Min	Max	Min	Max	
t <sub>trig</sub>	retrigger time	n $\bar{A}$ to nB; C <sub>EXT</sub> = 100 pF; R <sub>EXT</sub> = 1 k $\Omega$ ; C <sub>L</sub> = 50 pF; see Fig. 6 and Fig. 8								
		V <sub>CC</sub> = 3.0 V to 3.6 V	-	60	-	-	-	-	-	ns
		V <sub>CC</sub> = 4.5 V to 5.5 V	-	39	-	-	-	-	-	ns
		n $\bar{A}$ to nB; C <sub>EXT</sub> = 0.01 $\mu$ F; R <sub>EXT</sub> = 1 k $\Omega$ ; C <sub>L</sub> = 50 pF; see Fig. 6 and Fig. 8								
		V <sub>CC</sub> = 3.0 V to 3.6 V	-	1.5	-	-	-	-	-	$\mu$ s
		V <sub>CC</sub> = 4.5 V to 5.5 V	-	1.2	-	-	-	-	$\mu$ s	
C <sub>PD</sub>	power dissipation capacitance	C <sub>L</sub> = 50 pF; f <sub>i</sub> = 1 MHz; V <sub>I</sub> = GND to V <sub>CC</sub> [4]	-	57	-	-	-	-	-	pF
<b>74AHCT123A</b>										
t <sub>pd</sub>	propagation delay	n $\bar{A}$ and nB to nQ and n $\bar{Q}$ ; see Fig. 5 [2]								
		V <sub>CC</sub> = 4.5 V to 5.5 V; C <sub>L</sub> = 15 pF	-	5.0	12.0	1.0	14.0	1.0	15.5	ns
		V <sub>CC</sub> = 4.5 V to 5.5 V; C <sub>L</sub> = 50 pF	-	7.1	14.0	1.0	16.0	1.0	17.5	ns
		n $\bar{R}$ D to nQ and n $\bar{Q}$ ; see Fig. 5 [2]								
		V <sub>CC</sub> = 4.5 V to 5.5 V; C <sub>L</sub> = 15 pF	-	5.2	12.9	1.0	15.0	1.0	16.5	ns
		V <sub>CC</sub> = 4.5 V to 5.5 V; C <sub>L</sub> = 50 pF	-	7.5	14.9	1.0	17.0	1.0	18.5	ns
		n $\bar{R}$ D to nQ and n $\bar{Q}$ (reset); see Fig. 5 [2]								
		V <sub>CC</sub> = 4.5 V to 5.5 V; C <sub>L</sub> = 15 pF	-	4.7	9.4	1.0	11.0	1.0	12.0	ns
		V <sub>CC</sub> = 4.5 V to 5.5 V; C <sub>L</sub> = 50 pF	-	6.7	11.4	1.0	13.0	1.0	14.5	ns
t <sub>w</sub>	pulse width	inputs; n $\bar{A}$ = LOW; C <sub>L</sub> = 50 pF; see Fig. 5								
		V <sub>CC</sub> = 4.5 V to 5.5 V	5.0	-	-	5.0	-	5.0	-	ns
		inputs; nB = HIGH; C <sub>L</sub> = 50 pF; see Fig. 5								
		V <sub>CC</sub> = 4.5 V to 5.5 V	5.0	-	-	5.0	-	5.0	-	ns
		inputs; n $\bar{R}$ D = LOW; C <sub>L</sub> = 50 pF; see Fig. 5								
		V <sub>CC</sub> = 4.5 V to 5.5 V	5.0	-	-	5.0	-	5.0	-	ns
		outputs; n $\bar{Q}$ = LOW and nQ = HIGH; C <sub>L</sub> = 50 pF; C <sub>EXT</sub> = 28 pF; R <sub>EXT</sub> = 2 k $\Omega$ ; see Fig. 5, Fig. 6, Fig. 7 and Fig. 8 [3]								
		V <sub>CC</sub> = 4.5 V to 5.5 V	-	100	200	-	240	-	240	ns
		C <sub>EXT</sub> = 0.01 $\mu$ F; R <sub>EXT</sub> = 10 k $\Omega$								
		V <sub>CC</sub> = 4.5 V to 5.5 V	90	100	110	90	110	85	115	$\mu$ s
C <sub>EXT</sub> = 0.1 $\mu$ F; R <sub>EXT</sub> = 10 k $\Omega$										
V <sub>CC</sub> = 4.5 V to 5.5 V	0.9	1	1.1	0.9	1.1	0.85	1.15	ms		

Dual retriggerable monostable multivibrator with reset

Symbol	Parameter	Conditions	25 °C			-40 °C to +85 °C		-40 °C to +125 °C		Unit
			Min	Typ[1]	Max	Min	Max	Min	Max	
t <sub>trig</sub>	retrigger time	n $\bar{A}$ to nB; C <sub>EXT</sub> = 100 pF; R <sub>EXT</sub> = 1 k $\Omega$ ; C <sub>L</sub> = 50 pF; see Fig. 6 and Fig. 8								
		V <sub>CC</sub> = 4.5 V to 5.5 V	-	60	-	-	-	-	-	ns
		n $\bar{A}$ to nB; C <sub>EXT</sub> = 0.01 $\mu$ F; R <sub>EXT</sub> = 1 k $\Omega$ ; C <sub>L</sub> = 50 pF; see Fig. 6 and Fig. 8								
		V <sub>CC</sub> = 4.5 V to 5.5 V	-	1.5	-	-	-	-	-	$\mu$ s
C <sub>PD</sub>	power dissipation capacitance	C <sub>L</sub> = 50 pF; f <sub>i</sub> = 1 MHz; V <sub>I</sub> = GND to V <sub>CC</sub>	[4]	58	-	-	-	-	-	pF
<b>External components</b>										
R <sub>EXT</sub>	external resistance	V <sub>CC</sub> = 2.0 V	5	-	-	-	-	-	-	k $\Omega$
		V <sub>CC</sub> > 3.0 V	1	-	-	-	-	-	-	k $\Omega$
C <sub>EXT</sub>	external capacitance	V <sub>CC</sub> = 2.0 V	[5]	-	-	-	-	-	-	pF
		V <sub>CC</sub> > 3.0 V	[5]	-	-	-	-	-	-	pF

- [1] Typical values are measured at nominal supply voltage (V<sub>CC</sub> = 3.3 V and V<sub>CC</sub> = 5.0 V).
- [2] t<sub>pd</sub> is the same as t<sub>PLH</sub> and t<sub>PHL</sub>; C<sub>EXT</sub> = 0 pF; R<sub>EXT</sub> = 5 k $\Omega$ .
- [3] For C<sub>EXT</sub>  $\geq$  10 nF the typical value of the pulse width t<sub>w</sub> ( $\mu$ s) = C<sub>EXT</sub> (nF)  $\times$  R<sub>EXT</sub> (k $\Omega$ ).
- [4] C<sub>PD</sub> is used to determine the dynamic power dissipation P<sub>D</sub> ( $\mu$ W).  
 $P_D = C_{PD} \times V_{CC}^2 \times f_i + \sum(C_L \times V_{CC}^2 \times f_o)$  where:  
 f<sub>i</sub> = input frequency in MHz;  
 f<sub>o</sub> = output frequency in MHz;  
 C<sub>L</sub> = output load capacitance in pF;  
 V<sub>CC</sub> = supply voltage in V.
- [5] C<sub>EXT</sub> has no limits.

10.1. Waveforms and test circuit

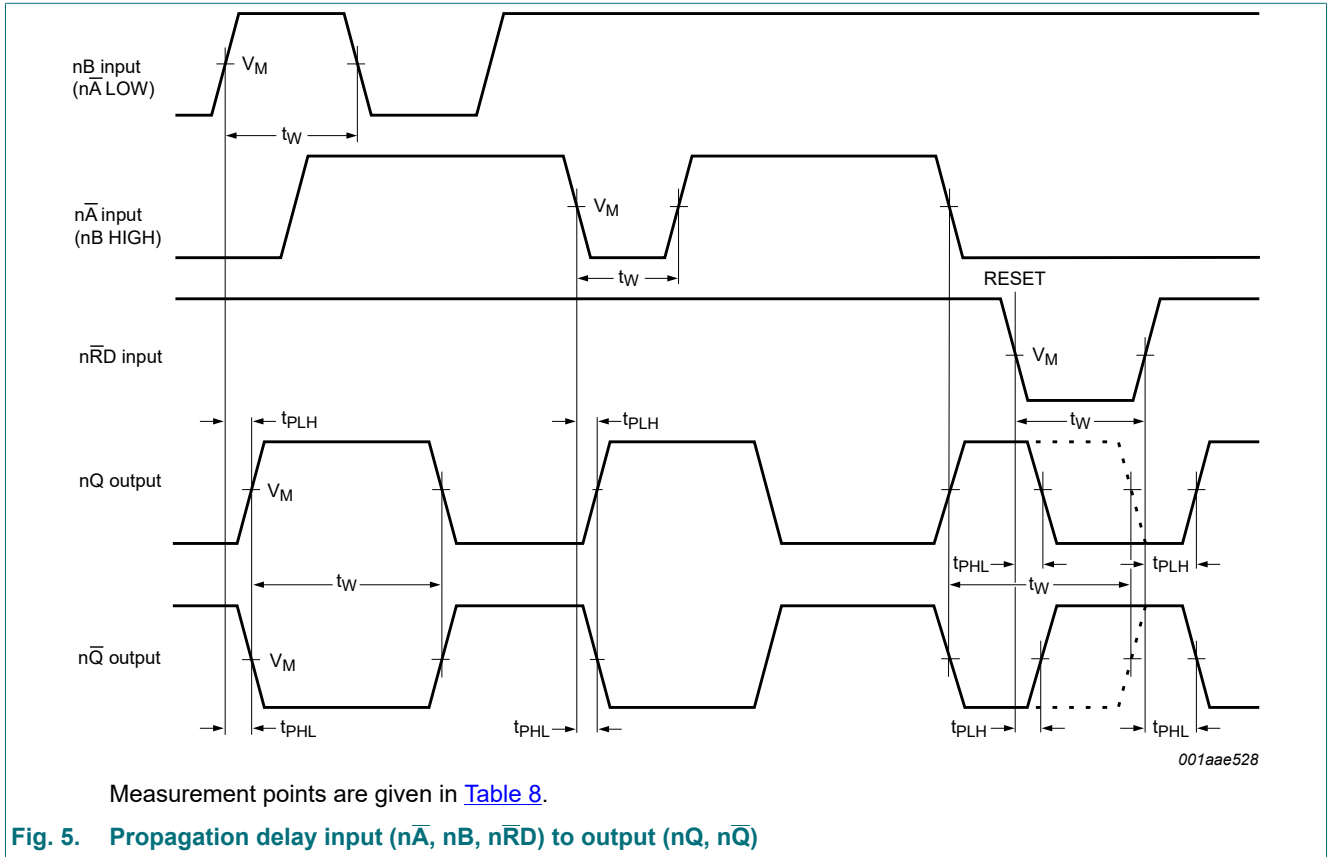
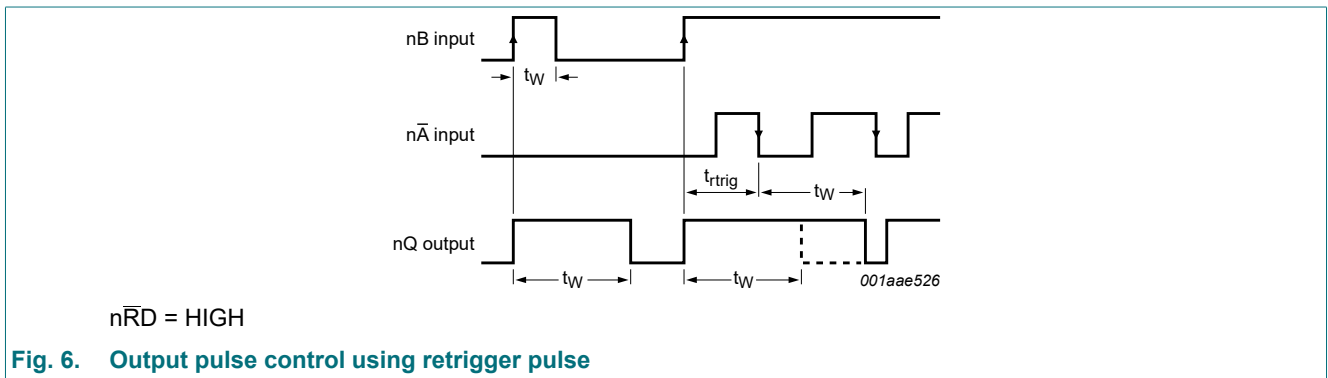
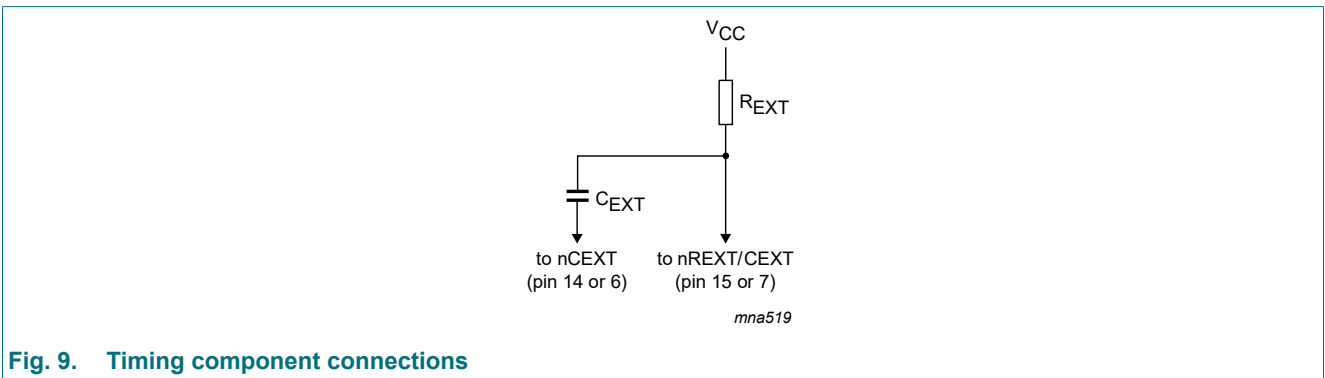
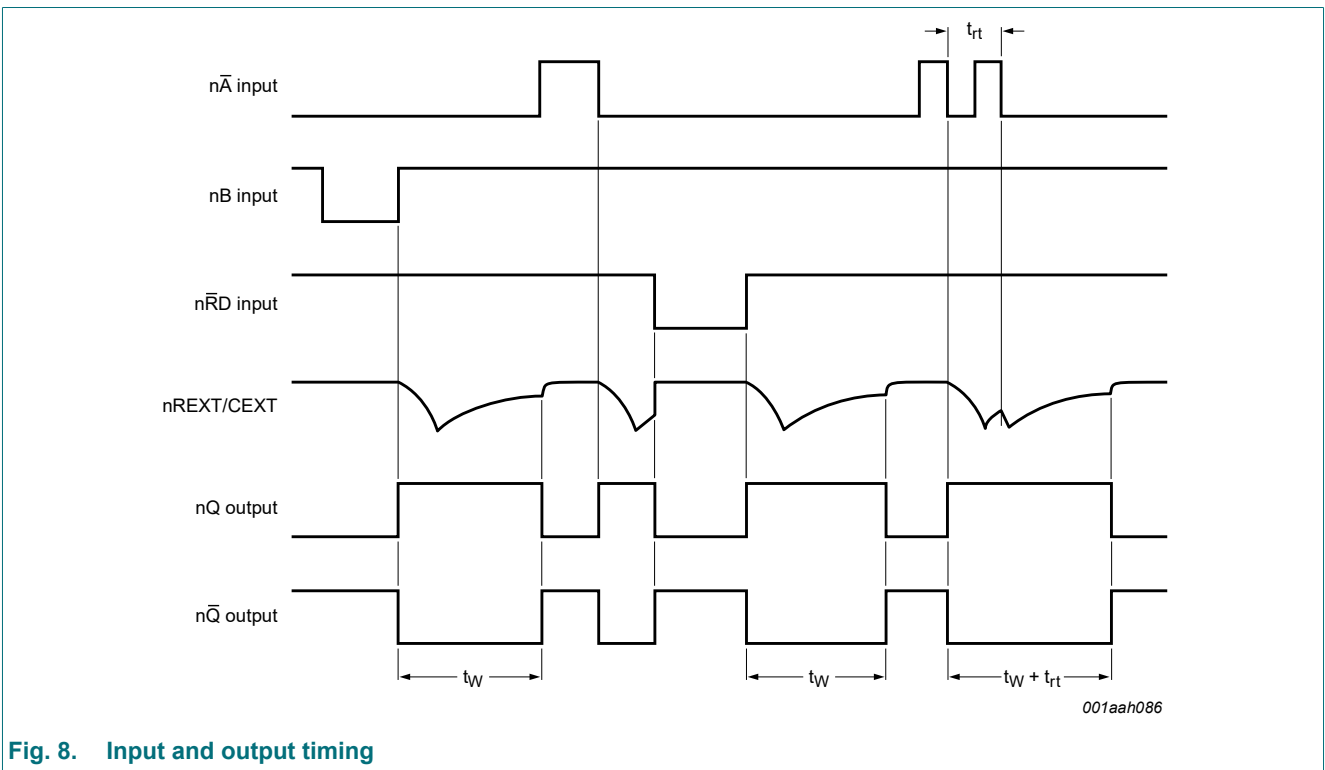
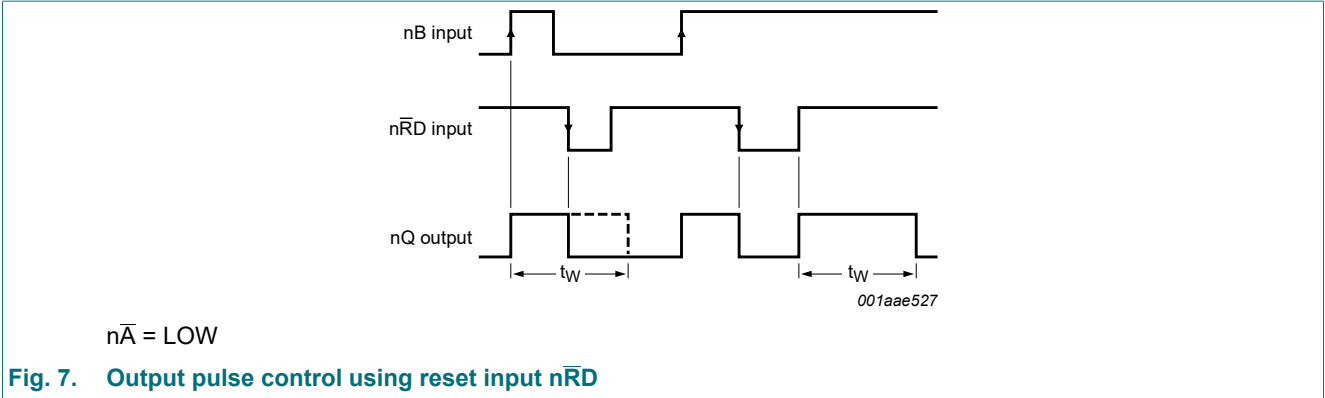

Table 8. Measurement points

Type	Input	Output
	$V_M$	$V_M$
74AHC123A	$0.5 \times V_{CC}$	$0.5 \times V_{CC}$
74AHCT123A	1.5 V	$0.5 \times V_{CC}$





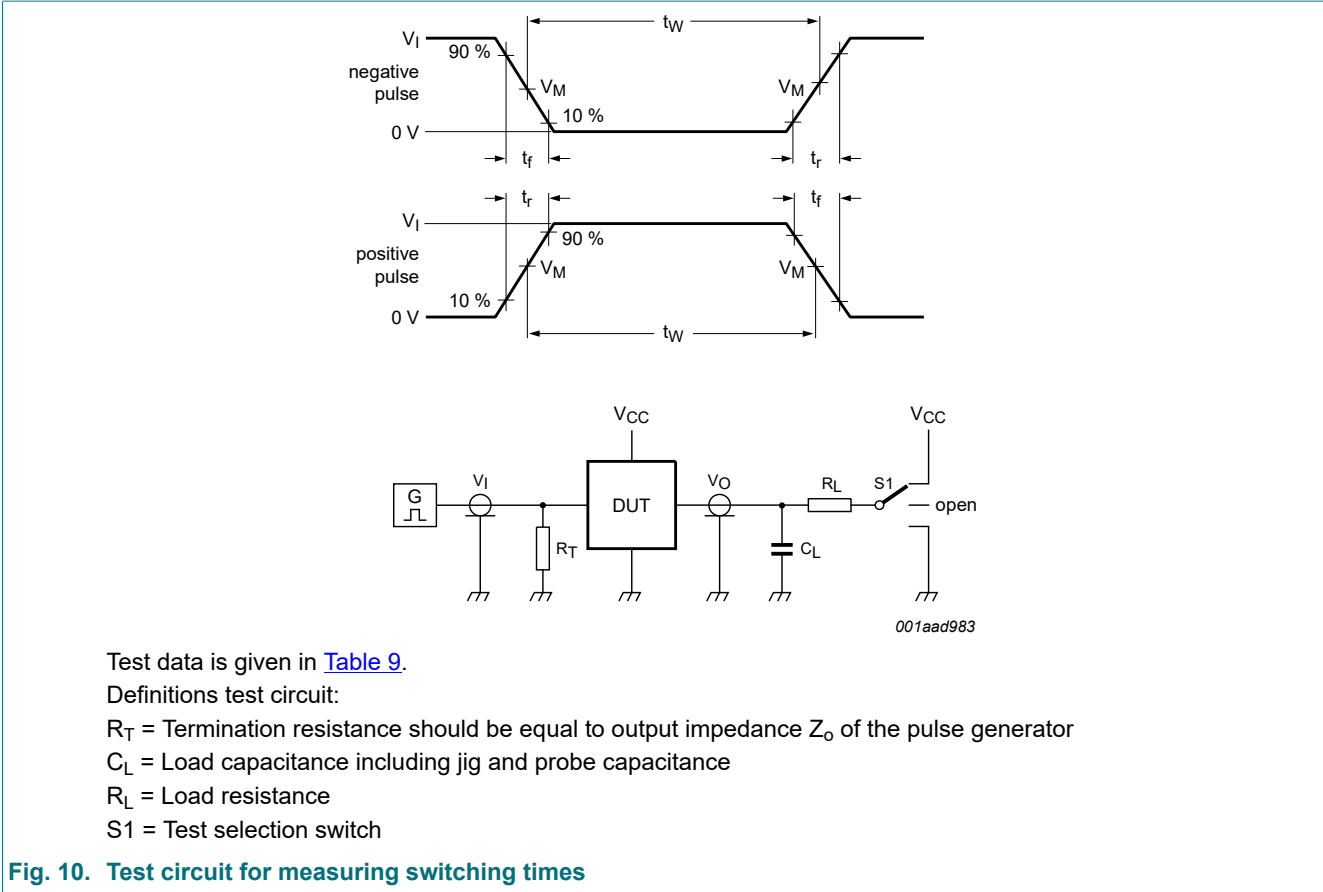

Fig. 10. Test circuit for measuring switching times

Table 9. Test data

Type	Input		Load		S1 position		
	$V_I$	$t_r, t_f$	$C_L$	$R_L$	$t_{PHL}, t_{PLH}$	$t_{PZH}, t_{PHZ}$	$t_{PZL}, t_{PLZ}$
74AHC123A	$V_{CC}$	3.0 ns	15 pF, 50 pF	1 k $\Omega$	open	GND	$V_{CC}$
74AHCT123A	3.0 V	3.0 ns	15 pF, 50 pF	1 k $\Omega$	open	GND	$V_{CC}$

11. Package outline

SO16: plastic small outline package; 16 leads; body width 3.9 mm

SOT109-1

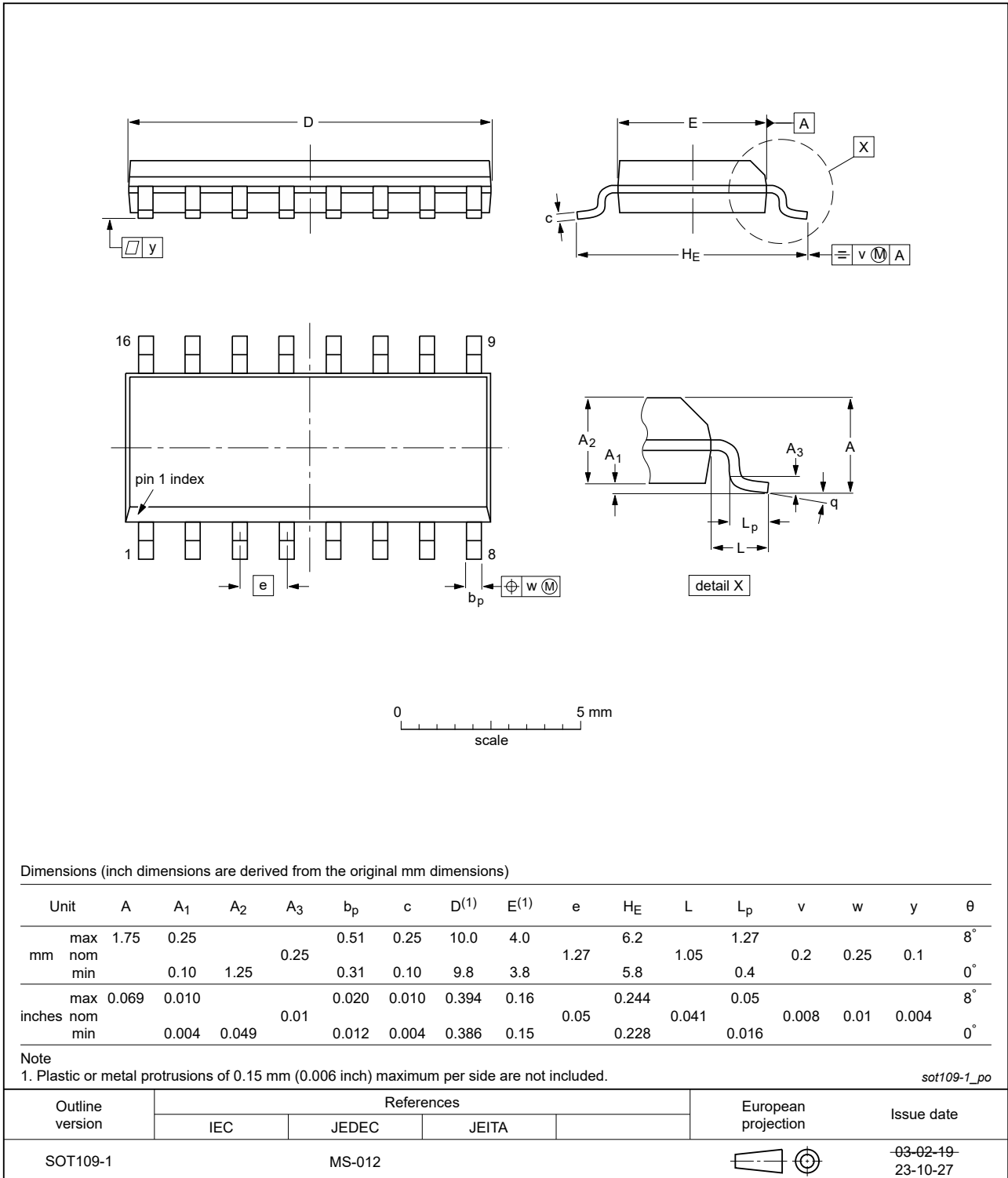

Fig. 11. Package outline SOT109-1 (SO16)

TSSOP16: plastic thin shrink small outline package; 16 leads; body width 4.4 mm

SOT403-1



Fig. 12. Package outline SOT403-1 (TSSOP16)

DHVQFN16: plastic dual in-line compatible thermal enhanced very thin quad flat package; no leads; 16 terminals; body 2.5 x 3.5 x 0.85 mm

SOT763-1



Fig. 13. Package outline SOT763-1 (DHVQFN16)

## 12. Abbreviations

Table 10. Abbreviations

Acronym	Description
CDM	Charged-Device Model
CMOS	Complementary Metal Oxide Semiconductor
DUT	Device Under Test
ESD	ElectroStatic Discharge
HBM	Human Body Model
TTL	Transistor-Transistor Logic

## 13. Revision history

Table 11. Revision history

Document ID	Release date	Data sheet status	Change notice	Supersedes
74AHC_AHCT123A v.7	20240228	Product data sheet	-	74AHC_AHCT123A v.6
Modifications:	<ul style="list-style-type: none"> <li><a href="#">Fig. 11</a>, <a href="#">Fig. 12</a>: Aligned SO and TSSOP package outline drawings to JEDEC MS-012 and MO-153.</li> </ul>			
74AHC_AHCT123A v.6	20230904	Product data sheet	-	74AHC_AHCT123A v.5
Modifications:	<ul style="list-style-type: none"> <li><a href="#">Section 2</a>: ESD specification updated according to the latest JEDEC standard.</li> </ul>			
74AHC_AHCT123A v.5	20200617	Product data sheet	-	74AHC_AHCT123A v.4
Modifications:	<ul style="list-style-type: none"> <li>The format of this data sheet has been redesigned to comply with the identity guidelines of Nexperia.</li> <li>Legal texts have been adapted to the new company name where appropriate.</li> <li><a href="#">Section 1</a> and <a href="#">Section 2</a> updated.</li> <li><a href="#">Table 4</a>: Derating values for <math>P_{tot}</math> total power dissipation updated.</li> </ul>			
74AHC_AHCT123A v.4	20111108	Product data sheet	-	74AHC_AHCT123A v.3
Modifications:	<ul style="list-style-type: none"> <li>Legal pages updated.</li> </ul>			
74AHC_AHCT123A v.3	20110908	Product data sheet	-	74AHC_AHCT123A v.2
74AHC_AHCT123A v.2	20080118	Product data sheet	-	74AHC_AHCT123A v.1
74AHC_AHCT123A v.1	20000315	Product specification	-	-

## 14. Legal information

### Data sheet status

Document status [1][2]	Product status [3]	Definition
Objective [short] data sheet	Development	This document contains data from the objective specification for product development.
Preliminary [short] data sheet	Qualification	This document contains data from the preliminary specification.
Product [short] data sheet	Production	This document contains the product specification.

- [1] Please consult the most recently issued document before initiating or completing a design.
- [2] The term 'short data sheet' is explained in section "Definitions".
- [3] The product status of device(s) described in this document may have changed since this document was published and may differ in case of multiple devices. The latest product status information is available on the internet at <https://www.nexperia.com>.

### Definitions

**Draft** — The document is a draft version only. The content is still under internal review and subject to formal approval, which may result in modifications or additions. Nexperia does not give any representations or warranties as to the accuracy or completeness of information included herein and shall have no liability for the consequences of use of such information.

**Short data sheet** — A short data sheet is an extract from a full data sheet with the same product type number(s) and title. A short data sheet is intended for quick reference only and should not be relied upon to contain detailed and full information. For detailed and full information see the relevant full data sheet, which is available on request via the local Nexperia sales office. In case of any inconsistency or conflict with the short data sheet, the full data sheet shall prevail.

**Product specification** — The information and data provided in a Product data sheet shall define the specification of the product as agreed between Nexperia and its customer, unless Nexperia and customer have explicitly agreed otherwise in writing. In no event however, shall an agreement be valid in which the Nexperia product is deemed to offer functions and qualities beyond those described in the Product data sheet.

### Disclaimers

**Limited warranty and liability** — Information in this document is believed to be accurate and reliable. However, Nexperia does not give any representations or warranties, expressed or implied, as to the accuracy or completeness of such information and shall have no liability for the consequences of use of such information. Nexperia takes no responsibility for the content in this document if provided by an information source outside of Nexperia.

In no event shall Nexperia be liable for any indirect, incidental, punitive, special or consequential damages (including - without limitation - lost profits, lost savings, business interruption, costs related to the removal or replacement of any products or rework charges) whether or not such damages are based on tort (including negligence), warranty, breach of contract or any other legal theory.

Notwithstanding any damages that customer might incur for any reason whatsoever, Nexperia's aggregate and cumulative liability towards customer for the products described herein shall be limited in accordance with the Terms and conditions of commercial sale of Nexperia.

**Right to make changes** — Nexperia reserves the right to make changes to information published in this document, including without limitation specifications and product descriptions, at any time and without notice. This document supersedes and replaces all information supplied prior to the publication hereof.

**Suitability for use** — Nexperia products are not designed, authorized or warranted to be suitable for use in life support, life-critical or safety-critical systems or equipment, nor in applications where failure or malfunction of an Nexperia product can reasonably be expected to result in personal

injury, death or severe property or environmental damage. Nexperia and its suppliers accept no liability for inclusion and/or use of Nexperia products in such equipment or applications and therefore such inclusion and/or use is at the customer's own risk.

**Quick reference data** — The Quick reference data is an extract of the product data given in the Limiting values and Characteristics sections of this document, and as such is not complete, exhaustive or legally binding.

**Applications** — Applications that are described herein for any of these products are for illustrative purposes only. Nexperia makes no representation or warranty that such applications will be suitable for the specified use without further testing or modification.

Customers are responsible for the design and operation of their applications and products using Nexperia products, and Nexperia accepts no liability for any assistance with applications or customer product design. It is customer's sole responsibility to determine whether the Nexperia product is suitable and fit for the customer's applications and products planned, as well as for the planned application and use of customer's third party customer(s). Customers should provide appropriate design and operating safeguards to minimize the risks associated with their applications and products.

Nexperia does not accept any liability related to any default, damage, costs or problem which is based on any weakness or default in the customer's applications or products, or the application or use by customer's third party customer(s). Customer is responsible for doing all necessary testing for the customer's applications and products using Nexperia products in order to avoid a default of the applications and the products or of the application or use by customer's third party customer(s). Nexperia does not accept any liability in this respect.

**Limiting values** — Stress above one or more limiting values (as defined in the Absolute Maximum Ratings System of IEC 60134) will cause permanent damage to the device. Limiting values are stress ratings only and (proper) operation of the device at these or any other conditions above those given in the Recommended operating conditions section (if present) or the Characteristics sections of this document is not warranted. Constant or repeated exposure to limiting values will permanently and irreversibly affect the quality and reliability of the device.

**Terms and conditions of commercial sale** — Nexperia products are sold subject to the general terms and conditions of commercial sale, as published at <http://www.nexperia.com/profile/terms>, unless otherwise agreed in a valid written individual agreement. In case an individual agreement is concluded only the terms and conditions of the respective agreement shall apply. Nexperia hereby expressly objects to applying the customer's general terms and conditions with regard to the purchase of Nexperia products by customer.

**No offer to sell or license** — Nothing in this document may be interpreted or construed as an offer to sell products that is open for acceptance or the grant, conveyance or implication of any license under any copyrights, patents or other industrial or intellectual property rights.

**Export control** — This document as well as the item(s) described herein may be subject to export control regulations. Export might require a prior authorization from competent authorities.

**Non-automotive qualified products** — Unless this data sheet expressly states that this specific Nexperia product is automotive qualified, the product is not suitable for automotive use. It is neither qualified nor tested in accordance with automotive testing or application requirements. Nexperia accepts no liability for inclusion and/or use of non-automotive qualified products in automotive equipment or applications.

In the event that customer uses the product for design-in and use in automotive applications to automotive specifications and standards, customer (a) shall use the product without Nexperia's warranty of the product for such automotive applications, use and specifications, and (b) whenever customer uses the product for automotive applications beyond Nexperia's specifications such use shall be solely at customer's own risk, and (c) customer fully indemnifies Nexperia for any liability, damages or failed product claims resulting from customer design and use of the product for automotive applications beyond Nexperia's standard warranty and Nexperia's product specifications.

**Translations** — A non-English (translated) version of a document is for reference only. The English version shall prevail in case of any discrepancy between the translated and English versions.

### Trademarks

Notice: All referenced brands, product names, service names and trademarks are the property of their respective owners.

## Contents

- 1. General description..... 1
- 2. Features and benefits..... 1
- 3. Ordering information..... 1
- 4. Functional diagram..... 2
- 5. Pinning information..... 4
  - 5.1. Pinning..... 4
  - 5.2. Pin description..... 5
- 6. Functional description..... 5
- 7. Limiting values..... 6
- 8. Recommended operating conditions..... 6
- 9. Static characteristics..... 7
- 10. Dynamic characteristics..... 9
  - 10.1. Waveforms and test circuit..... 12
- 11. Package outline..... 15
- 12. Abbreviations..... 18
- 13. Revision history..... 18
- 14. Legal information..... 19



---

© Nexperia B.V. 2024. All rights reserved  
For more information, please visit: <http://www.nexperia.com>  
For sales office addresses, please send an email to: [salesaddresses@nexperia.com](mailto:salesaddresses@nexperia.com)  
Date of release: 28 February 2024

---

## Looking for pricing, stock, or lifecycle information?

Click below to explore more details on WIN SOURCE:

-  [View 74AHCT123ABQ,115 on WIN SOURCE](#)
-  [Nexperia USA Inc. Information](#)

## Optimize Your Supply Chain with WIN SOURCE Solutions

-  Global Sourcing Solution
-  Obsolete Management
-  Cost Control Management
-  Shortage Management
-  Alternative Solution
-  Excess Inventory Management